

(No Model.)

W. M. McCOLLUM.

AUTOMATIC BRAKE.

No. 362,101.

Patented May 3, 1887.

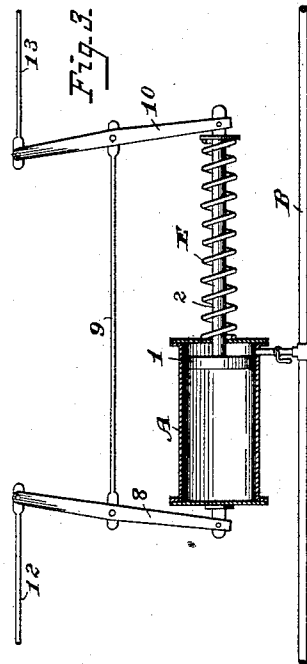
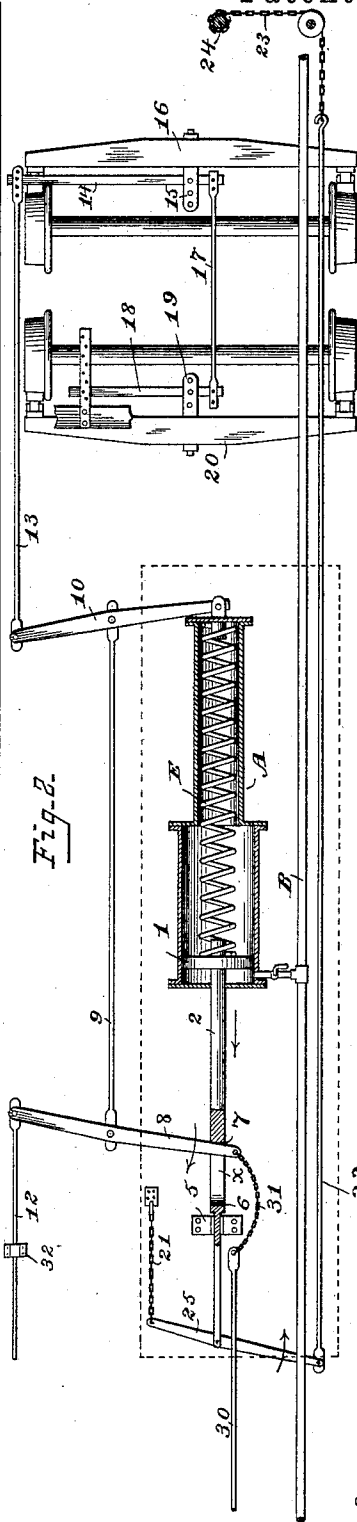
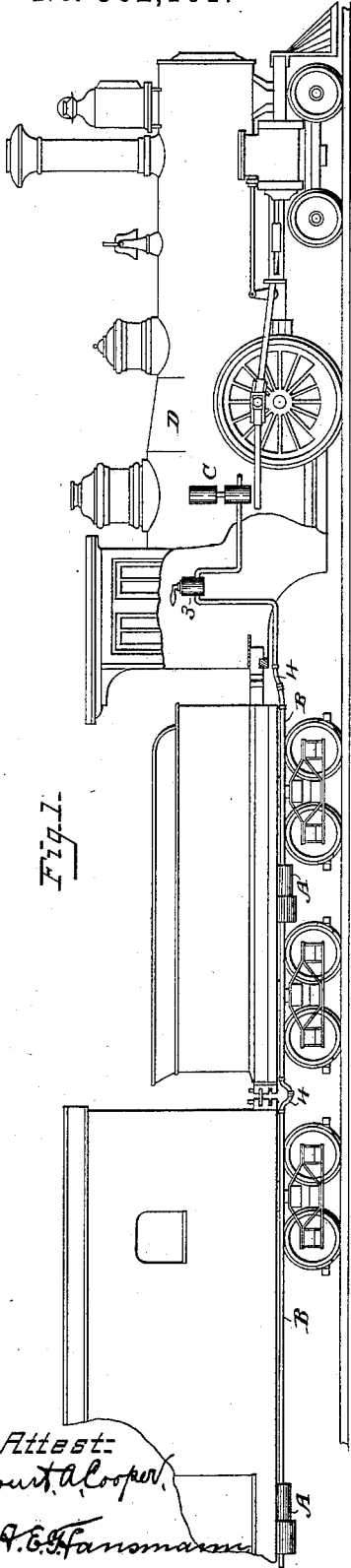

Attest:  
 Court A. Cooper,  
 A. C. Panomassi

Witness  
 Wm. Rogers McCollum  
 Inventor:  
 J. Foster & Freeman  
 Attys.

# UNITED STATES PATENT OFFICE.

WILLIAM MYERS McCOLLUM, OF CINCINNATI, OHIO.

## AUTOMATIC BRAKE.

SPECIFICATION forming part of Letters Patent No. 362,101, dated May 3, 1887.

Application filed July 2, 1886. Serial No. 906,973. (No model.)

*To all whom it may concern:*

Be it known that I, WILLIAM MYERS McCOLLUM, a citizen of the United States, and residing at Cincinnati, Hamilton county, Ohio, have invented certain new and useful Improvements in Automatic Brakes, of which the following is a specification.

My invention has for its object to control the brakes of railway-cars; and it consists in means, fully set forth hereinafter, whereby all brakes of a car or train may be applied by the pressure of springs acting to carry the pistons or cylinders upon the cars in one direction, and whereby the brakes may be released at the will of the engineer by bringing the fluid under pressure against the opposite sides of said pistons.

In the drawings, Figure 1 is a side elevation showing a locomotive and cars sufficiently in detail to illustrate my invention. Fig. 2 is an enlarged plan view inverted and in part section, showing the brake apparatus of a single car. Fig. 3 is a plan view illustrating a modification.

Each of the cars is provided with a cylinder, A, containing a piston, 1, the rod 2 of which projects through the head of the cylinder, and each cylinder communicates at one end with a pipe, B, for conveying air, water, steam, or other fluid from the engine D, a pump, C, being used when a fluid other than steam is employed, and a cock, 3, in the engineer's cab serving to regulate the flow.

Flexible coupling-pipes 4 serve to connect the contiguous ends of the pipes B of different cars that may constitute a train, in the same manner as with ordinary air-brakes.

The piston 1 is forced toward the end of the cylinder that communicates with the pipe B by means of a spring, E, and when the piston is in the position that it occupies when nearest the inlet of the pipe B the spring is under such tension that it will exert the power requisite to apply the brakes to all the wheels through the medium of suitable connections with the piston-rod 2; but when the piston is moved toward the opposite end of the cylinder by the pressure of air or other fluid admitted to the cylinder by the action of the engineer in turning the cock 3 the brake-connections are relieved from pressure, and the brakes are withdrawn from the wheels.

Different arrangements of brakes and brake-connections between the brakes and the piston-rod may be employed. In Fig. 2 the piston-rod 2 passes through a guide, 5, near the outer end, and has a slot, *x*, with two shoulders, 6, 7, and through this slot extends one end of a brake-lever, 8, the opposite end of which is connected by a rod, 12, with the levers of the brake-beams at one end of the car, the lever 8 and rod 12 being held in proper relative position by any suitable means—as, for instance, by a guide, 32. The lever 8 is centrally connected by a rod, 9, to a lever, 10, pivoted at one end to one head of the cylinder and connected at the other to a rod, 13, which is connected to a lever, 14, pivoted to an ear, 15, upon the outer brake beam, 16, at the opposite end of the car. The inner end of the lever 14 is connected by a rod, 17, to the inner end of the lever 18, pivoted at the opposite end to a bearing upon the car, and also to an ear, 19, at the center of the inner brake-beam, 20.

The above-described parts are arranged so that when the piston 1 is at the limit of its outer motion the shoulder 7 of the slot *x* will bear against the inner end of the lever 8, and the pressure of the spring E will carry said lever 8 in the direction of its arrow, (shown in Fig. 2,) and cause all the brakes to be applied.

When air, steam, or other fluid is forced into the cylinder A from the pipe B, the piston 1 will be carried in the opposite direction, so as to remove the shoulder 7 from the lever 8, and thus relieve the brakes.

I have shown in Fig. 2 a single spring contained within the cylinder and an extension thereof; but two or more springs may be arranged to bear upon the piston, or, as shown in Fig. 3, the spring or springs may have a bearing upon the piston-rod, and the spring may be a coiled spring or a bow or other form of spring, the action being the same in all cases—that is, the spring or set of springs acting upon the piston apply all the brakes, while the reverse movement of the piston from the inflowing fluid, controlled by the engineer, relieves simultaneously all the brakes in all the cars.

Inasmuch as the action of the spring is to apply the brakes, the latter must be held out of action by the continued pressure of the

fluid in the cylinders, so that should an accident occur, causing a rupture or leakage of any of the pipes, or should a car become accidentally detached, the fluid would at once escape from the cylinder and the piston would be forced toward the escape-port, and the brakes at once be automatically applied.

In order to operate the brakes by hand when the car is detached from the engine, or in case of the automatic-brake device becoming inoperative from any reason, I use a hand device and connections between the same and the piston-rod, whereby the latter may be forced back from contact with the lever 8, or released to make contact therewith, the slot *x* permitting the end of the lever 8 to play independently of the piston and piston-rod. Thus a lever, 25, connected at one end to a pivotal chain, 21, is connected at the opposite end to a rod, 22, extending to a chain, 23, attached to a windlass or hand-shaft, 24, which is provided with the usual hand-wheel, and the lever 25 is centrally pivoted to the end of the piston-rod 2. By turning the shaft 24 to wind up the chain 23 the lever 25 is swung in the direction of its arrow, and, with its piston-rod, is forced back so as to carry the shoulder 7 from the lever 8, and thus leave the brakes free from pressure, while by releasing the chain 23 the parts will be moved in a reverse direction, and the pressure of the spring will swing the lever 8 so as to apply the brakes.

In order to apply the brakes by hand should the spring become broken, a rod, 30, operatively connected with a hand operating device, is connected by a chain, 31, to the end of the lever 8, which may be swung in the direction of its arrow to apply the brakes by carrying the rod 30 longitudinally outward.

Without limiting myself to the precise construction and arrangement of parts shown, I claim—

1. The combination, with the brake-beams and connections of a railway-car, of a cylinder containing a piston having a rod bearing upon one of the said connections, a spring interposed between the cylinder and piston and acting upon the piston to carry the latter in

a direction to apply the brakes, and a pipe and inlet, whereby fluid under pressure may be admitted to the cylinder to force back the piston against the power of the spring and relieve the brakes, substantially as set forth. 5c

2. The combination, with a car, of a cylinder provided with a piston and piston-rod, the latter having a shoulder for bearing upon one of the brake-levers, a spring arranged to carry the piston in one direction to bring said shoulder against the brake-lever, and a pipe communicating with the cylinder for conducting the fluid under pressure against the other side of the piston, substantially as set forth. 65

3. The combination, with a car, of a cylinder containing a piston and a spring bearing upon one side thereof, a pipe communicating with the cylinder at the opposite side of the piston, and a piston-rod provided with a shoulder arranged to bear against one of the brake-levers when the piston is forced outward by the spring, substantially as set forth. 70

4. The combination of the cylinder, spring, and fluid-pipe communicating with the cylinder, of a piston-rod provided with a bearing for one of the brake-levers upon one side of the latter, but permitting a movement of said lever independent of the piston-rod, and a second lever connected to the piston-rod and to a hand operating device, whereby the piston-rod can be forced back to carry the bearing from the lever, substantially as set forth. 80

5. The combination, with the cylinder, piston, piston-rod having a bearing, 7, and with the braking-spring, of a lever, 8, arranged to contact at its inner end with said bearing, connections, substantially as described, between the lever, cylinder, and brake-bearings, and a hand device, and rod 30, connecting the latter to the inner end of said lever 8, as and for the purpose set forth. 85

In testimony whereof I have signed my name to this specification in the presence of two subscribing witnesses. 90

WM. MYERS McCOLLUM.

Witnesses:

A. E. HANSMANN,  
W. C. DUVALL.