



(11)

**EP 3 906 976 A2**

(12) **EUROPEAN PATENT APPLICATION**

(43) Date of publication:  
**10.11.2021 Bulletin 2021/45**

(51) Int Cl.:  
**A62C 35/10 (2006.01)** **A62C 37/14 (2006.01)**  
**A62C 37/40 (2006.01)**

(21) Application number: **20217871.1**

(22) Date of filing: **30.12.2020**

(84) Designated Contracting States:  
**AL AT BE BG CH CY CZ DE DK EE ES FI FR GB GR HR HU IE IS IT LI LT LU LV MC MK MT NL NO PL PT RO RS SE SI SK SM TR**  
Designated Extension States:  
**BA ME**  
Designated Validation States:  
**KH MA MD TN**

• **CORDEEL, Filip**  
**9140 TEMSE (BE)**  
• **BOSTEELS, Floris**  
**2850 BOOM (BE)**

(74) Representative: **Ostyn, Frans et al**  
**KOB NV**  
**President Kennedypark 31 c**  
**8500 Kortrijk (BE)**

(30) Priority: **31.12.2019 BE 201906008**

(71) Applicant: **ECOSOURCEn**  
**9140 Temse (BE)**

Remarks:

Claims 16 - 29 are deemed to be abandoned due to non-payment of the claims fees (Rule 45(3) EPC).

(72) Inventors:  
• **BOSTEELS, Dany**  
**2850 BOOM (BE)**

(54) **FIRE PROTECTION DEVICE**

(57) The present invention relates to a fire protection device with, in each room, an extinguishing unit (1, 2, 3) with an extinguishing agent reservoir (1) activatable by a detecting means; an extinguishing agent with at least one additive that comprises a plant extract and/or a mineral salt of an acid, preferably extinguishing foam; a fire protection device comprising an actuator (10)-(40) in order to break a breakable activation or detection element (2a) of an extinguishing or alarm device and/or a sensor unit assembled by selecting one or more desired sensor modules from a number of available sensor modules, and/or a sensor designed to detect the presence of substances in the air and to evaluate the harmfulness thereof.

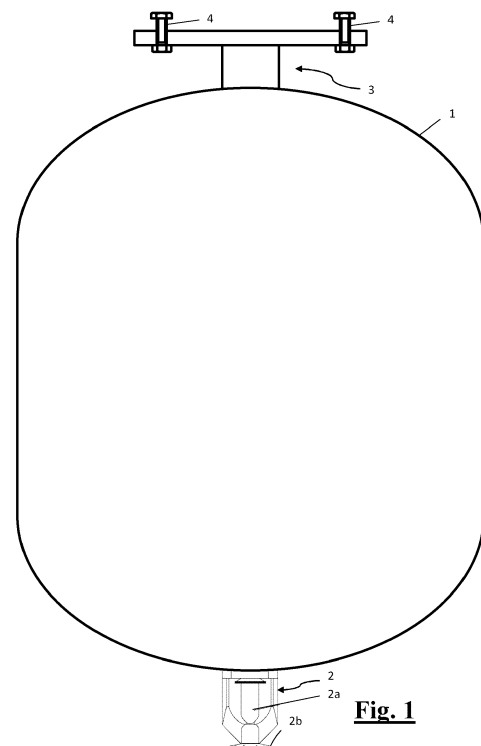

**Fig. 1**

**EP 3 906 976 A2**

## Description

**[0001]** The present invention relates to a fire protection device for protecting at least one room, comprising a detection device for detecting one or more fire parameters, and an extinguishing device, which is provided for delivering an extinguishing agent into each protected room, wherein the detection device is designed to activate the extinguishing device in a room on detection of at least one fire parameter.

**[0002]** In this patent application, 'a fire protection device' means a device by which the development of a fire in a room can be prevented or delayed or by which a fire can be extinguished or by which the propagation of a fire can be prevented or delayed. Moreover, the term 'fire' refers not only to literal burning, in the presence of a flame, but also to smouldering or glowing without a flame.

**[0003]** In this patent application, 'a fire parameter' means a parameter that is associated with the presence of a fire or an incipient fire or with the development of a fire, e.g. in the case of smouldering or melting of an object or if an apparatus or a machine is in an overheated state. A fire parameter of this type is for example a certain temperature rise of the ambient air within a certain period of time or the presence in the air, or presence above a certain threshold concentration in the air, of a particular gas or of a combination of two or more gases or the presence of smoke. The detection device may also be arranged in such a way that it only activates the extinguishing device when two or more fire parameters are detected together.

**[0004]** The term 'room' means both a room enclosed by walls and a completely or partially open space. This term may also be used in the sense of a zone that is not delimited. In a number of fields of application, the room will be located within a building, for example such as a kitchen, a bedroom or a living room of a dwelling, an office room, a shop room, a stockroom, a storage room, a hotel room, a room for student accommodation, a garage, a machine room, a lift shaft, a car park, a workplace, a stable, but in other possible fields of application the room may also be located in a temporary structure, for example such as a marquee, or in a space of a means of transport, for example such as a loading space of a lorry or a train or the space inside a caravan or a boat. This is not an exhaustive list.

**[0005]** The term 'extinguishing agent' means any existing solid, liquid or gaseous extinguishing agent, for example such as a gas or a gas mixture with extinguishing properties or an extinguishing powder or an extinguishing foam or water that has been treated and/or to which one or more additives have been added in order to improve its extinguishing properties or to increase safety during extinguishing.

**[0006]** It is known to protect a number of different rooms in a building against fire by means of a sprinkler system that comprises several sprinkler heads, which are connected to a common mains system. This mains system is connected to a supply pipe, via which extin-

guishing agent is supplied, for example a water mains, or to a storage tank in which a supply of extinguishing agent is provided. Each sprinkler head protects a respective room. A sprinkler head is activated when a predetermined threshold temperature is reached. For this purpose most sprinkler heads are provided with a closed glass bulb that closes the nozzle. The glass bulb, also called a glass tube, contains a liquid which when heated expands so that the glass tube breaks and the extinguishing agent is sprayed into the room via the sprinkler head. The threshold temperature is often set at 30°C above the normal temperature in the room.

**[0007]** The mains system of the known sprinkler systems must extend from the supply pipe or the storage tank into the various rooms to be protected and so is often quite extensive. If the rooms to be protected are far apart, the mains system must also in each case bridge the distance between them and extend over a considerable distance. In addition, the extensive mains system must constantly remain under pressure, so that it is susceptible to leaks. Another drawback is that damage or defects on the mains system may have the consequence that there is no longer a supply of extinguishing agent to a number of sprinkler heads.

**[0008]** The aim of the present invention is to rectify the aforementioned drawbacks.

**[0009]** This aim is achieved by providing a fire protection device with the characteristic features from the first paragraph of this description, wherein, according to the present invention, in each protected room an extinguishing unit is provided, which comprises a reservoir in which a quantity of extinguishing agent is provided, and which is arranged to deliver extinguishing agent from the reservoir into said room, on detection of at least one fire parameter.

**[0010]** Preferably the fire protection device protects two or more rooms, and an extinguishing unit of this kind is provided in each room.

**[0011]** Detection of a fire parameter that activates an extinguishing device does not necessarily occur in the room where this extinguishing unit is located. Thus, for example on detection in a certain room, extinguishing agent may be sprayed preventively in other rooms of the same building, for example in the rooms that are located next to or above or under the room where detection of a fire occurred. Possible spread of the fire is stopped or at least delayed thereby.

**[0012]** According to the present invention, a separate fire protection device operating autonomously, with its own supply of extinguishing agent, is thus placed in each room to be protected against fire. It is therefore no longer necessary to provide an extensive pipe system that is permanently under pressure and that connects all rooms that are to be protected against fire to one another.

**[0013]** Activation of the extinguishing device for example involves opening a discharge orifice so that a quantity of extinguishing agent flows or is sprayed from the reservoir or is delivered in any way from the reservoir into

the protected room. Preferably each extinguishing unit comprises an extinguishing head connected to the reservoir with an opening via which the extinguishing agent can be delivered from the reservoir into the protected room. The extinguishing head may for example be a known sprinkler head.

**[0014]** Of course, the reservoir need not necessarily be connected to a supply pipe or another reservoir, but this is nevertheless included in the possibilities for supplying extinguishing agent to the extinguishing unit. Preferably the extinguishing agent is provided under pressure in the reservoir, for example at a pressure of 6 bar. The reservoir preferably has a cubic capacity of 1 litre or 2 litres or 4 litres or 6 litres or 9 litres.

**[0015]** On activation of the extinguishing device, the extinguishing agent is for example allowed to spray out of the reservoir via a spraying element that operates and/or is formed in such a way that the extinguishing agent is distributed into the environment around it. The spraying element is preferably adjusted in such a way that the extinguishing agent is distributed over the whole room to be protected.

**[0016]** The extinguishing properties of the extinguishing agent itself and/or the amount of extinguishing agent that is distributed in the room (determined by, among other things, the size of the reservoir) and/or the length of time during which the extinguishing agent is distributed, are preferably defined so that the extinguishing effect of the whole extinguishing activity is adapted to the flammability of the products or objects present in the room.

**[0017]** The extinguishing properties of the extinguishing agent and/or the amount of extinguishing agent and/or the extinguishing time may for example (also) be adapted to the accessibility of the protected room for the execution of extinguishing activities by a person summoned for this. The estimated time interval between informing the fire brigade and the start of extinguishing activities by the fire brigade is for example taken into account.

**[0018]** Preferably the extinguishing effect of the whole extinguishing activity coincides with the extinguishing effect of extinguishing for at least 60 minutes with ordinary water from a conventional sprinkler head. Depending on the circumstances and the wishes and needs and/or to satisfy any legal requirements, the extinguishing effect may be allowed to coincide with a shorter (e.g. at least 30 minutes or at least 45 minutes) or a longer duration (e.g. at least 75 minutes or at least 90 minutes) of extinguishing with ordinary water from a conventional sprinkler head.

**[0019]** The present invention also relates to an extinguishing unit for protecting a room against fire, comprising a reservoir that is provided for providing a quantity of extinguishing agent, an extinguishing head connected to the reservoir with a discharge orifice for delivering extinguishing agent from the reservoir into the protected room, and a detection and activation device that is arranged to open the discharge orifice of the extinguishing head on

detection of one or more fire parameters.

**[0020]** The present invention also relates to a set of extinguishing units for protecting a number of rooms against fire, with the properties indicated in the preceding paragraph. Each extinguishing unit is then provided to be placed in a respective room and thus create a fire protection device with the properties stated above.

**[0021]** According to a second aspect of the present invention, an extinguishing agent is provided, e.g. water, to which an additive is added that comprises a plant extract and/or a mineral salt of an acid.

**[0022]** An extinguishing agent of this kind is preferably provided in the reservoir of an extinguishing unit according to the present invention described above. The extinguishing agent may however also be used for extinguishing without making use of an extinguishing unit of this kind. The extinguishing agent may moreover be delivered into a room in any way.

**[0023]** The additive is preferably an extinguishing foam, such as an ecological telomer-based foam, preferably without persistent, bio-accumulative and toxic constituents, or a fluorine-free foam or a foam of class A. Said foam of class A is a mixture of water, air and a wetting agent and was specially developed for combating forest fires and extinguishing burning waste etc.

**[0024]** Depending on the circumstances, according to the present invention, for example for the following rooms to be protected, the following extinguishing agents are used (the percentages stated hereunder are ratios of the volume of the additive to the volume of water):

- for protecting emergency exits and rooms in houses: a mixture of water and 6% class A foam additive (water-based, bio, based on salts of mineral acids) + 1.5% fluorine-free foam (especially suitable for burning substances of classes B and F).
- for protecting rooms in which motors, machines, boilers etc. are installed: a mixture of water and 6% class A foam additive and 12% wetting agent (a bio premix, i.e. a mixture of products that contains plant extracts, among other things) and 1.5% fluorine-free foam, especially suitable for burning substances of classes B and F.
- for protecting rooms in which electrical equipment is installed, such as transformers, among other things: a mixture of water and 6% class A foam additive and 12% wetting agent (a bio premix, i.e. a mixture of products that contains plant extracts, among other things).

**[0025]** The mixing ratios are adjusted and/or extra additives are added, depending on the precise circumstances.

**[0026]** The liquid extinguishing agent is for example water that has undergone a treatment, for example a treatment at the nanoscale, so that it has a reduced con-

ductivity or is non-conductive. The extinguishing agent preferably comprises a wetting agent and/or a surfactant.

**[0027]** Each additive is preferably added at a mixing ratio relative to the extinguishing agent from 1.5% to 15%. The additive is for example very suitable in itself for extinguishing burning substances of classes A (wood, paper, etc.), B (oil, petrol, etc.), and F (fats, frying oil, etc.).

**[0028]** The present invention also relates to any type of fire protection device, in particular a fire protection device according to the first, third, fourth or fifth aspect of the present invention, in which an extinguishing agent according to the present invention is provided.

**[0029]** According to a third aspect of the present invention, an actuator is provided for activating an extinguishing device or a fire alarm device that comprises a breakable detection element or a breakable activation element. This breakable part is for example a closed container in which a liquid or a gas is provided. The breakable part is preferably made of glass.

**[0030]** There are fire detection devices that are provided with a breakable element that breaks at a predetermined rupture temperature and activates an extinguishing device thereby.

**[0031]** The breakable element is for example in the form of a glass bulb. This is the case in known sprinkler systems. Each sprinkler head is provided with a glass tube that is designed to break on exceeding a certain temperature limit, typically 68°C, so that the nozzle of the sprinkler head in question is opened and extinguishing agent is sprayed into the protected room or zone.

**[0032]** There are also manually activatable extinguishing devices or fire alarm devices with an activation element that goes into the activation state by breaking a breakable part, in the form of a glass plate, wherein a fire alarm is generated or an extinguishing device is activated by manually breaking the glass plate.

**[0033]** When, in rooms in which such existing devices are provided, we wish to provide a fire protection device whose extinguishing device is activatable by some other detection element or by some other activation element than the activation or detection element already present, major adjustments are often necessary.

**[0034]** The aim of the present invention is to rectify this drawback.

**[0035]** According to the present invention, this aim is achieved by providing an actuator that is designed to be installed in the vicinity of a breakable detection element or a breakable activation element, and which comprises a breaking device in order to break said breakable part, wherein the actuator is activatable by means of a signal that is generated by another detection device.

**[0036]** An actuator of this kind with the characteristic features that are described in the preceding paragraph and hereunder and are presented in the claims, may be incorporated in a fire protection device with the features described above relating to the first aspect of the present invention, but may also be used in any other type of fire protection device to activate an extinguishing device or

an alarm device with a breakable detection element or a breakable activation element by means of another activation means or detecting means.

**[0037]** The present invention thus also relates to any fire protection device, in particular a fire protection device with the features according to the first aspect of the present invention, which comprises a breakable activation or detection element for activating an alarm device or an extinguishing device, and an actuator that is designed to break the breakable activation or detection element, wherein the actuator is activatable by another activation means or detecting means.

**[0038]** For example, in order to be able to activate a sprinkler head of an existing sprinkler installation by means of a detection element other than the glass tube that is present, the present invention provides an actuator that is designed to break the glass tube as a result of detection of at least one fire parameter by said other detection element. This other detection element is for example a detection element for detecting the presence of smoke or of a gas.

**[0039]** In the case of an activation element with a breakable part, such as a sheet-form glass element that is designed to be broken manually, the actuator may be set up in such a way that this sheet-form element breaks as a result of detection of at least one fire parameter, by any detection element.

**[0040]** For this purpose, the actuator may comprise a breaking device that comprises a movable breaking means for breaking the breakable activation or detection element by contact with the breaking means, for example such as by striking it. The breaking device may also be provided with heating means for heating the breakable activation or detection element until it breaks, in other words by heating until it reaches the rupture temperature, wherein the heat required for this is obtained for example by burning a gas or by means of an electric current. The breaking device may also be designed to create a gas stream or liquid stream directed onto the breakable activation or detection element in order to break it, wherein the breakable element is for example broken by the pressure that is exerted by said gas or liquid stream on that element.

**[0041]** In a preferred embodiment, the actuator is a module that is fastened on or against a breakable activation element or detection element of a sprinkler head of a sprinkler installation and is designed to break the breakable element thereof.

**[0042]** A number of possible embodiments of an actuator with a breaking device according to the present invention are described hereunder.

**[0043]** An example of an actuator with a mechanically acting breaking device comprises a motor that is designed to move a needle or a pin by means of a drive mechanism so that the needle or the pin pushes against or strikes the glass tube and breaks the glass tube.

**[0044]** An actuator with a thermally acting breaking device comprises for example an electric heating element

that heats a metal plate in the vicinity of a sprinkler head. As a result, the glass tube of the sprinkler head is heated until it reaches the rupture temperature. In an alternative embodiment, a flame is generated and is directed onto the sprinkler head, with the same effect.

**[0045]** According to yet another possibility, the breaking device comprises a reservoir, in which a gas or a liquid is stored at high pressure, which is installed in the vicinity of the sprinkler head. By the sudden opening of this reservoir, a powerful gas stream or liquid stream is created, which is directed onto the glass tube of the sprinkler head, and the latter breaks owing to the pressure exerted thereon.

**[0046]** Additional features of a number of preferred embodiments of an actuator according to the present invention are presented in the following.

**[0047]** An actuator consists for example of three components, namely a communication module, a breaking device and a battery. These components are connected together and interact. The communication module may operate at various frequencies, preferably in the standard band 868 MHz or 433 MHz. The battery is replaceable and may have various capacities.

**[0048]** In a mechanically acting embodiment, the breaking device comprises for example a motor that drives a gear system. The gear system is designed to move a pin along its longitudinal direction, so that it strikes the glass tube at high speed and causes it to break. It is possible to select a gear system with two interacting gears that are located on both sides of the pin or on either side of a pin holder, and engage on this pin or this pin holder. It is also possible to select just one gear, which engages on the pin or pin holder. For this purpose, engaging means are provided on the pin or on the pin holder, for example such as teeth that are designed to interact with the at least one gear of the gear system. By driving the single gear or at least one of the two gears, wherein these two gears turn in an opposite sense of rotation, the pin can be moved in the direction of the glass tube. It is possible to select driving of both gears by means of a respective motor or driving of only one of the two gears. Driving of both gears offers greater operational reliability.

**[0049]** In a first example of a thermally acting embodiment, the breaking device comprises a heat source, the heat of which is obtained electrically. In a second example of a thermally acting embodiment, the breaking device comprises a heat source whose heat is obtained by burning a gas.

**[0050]** The heat required  $Q$  to obtain a desired temperature increase  $\Delta t$  of an object of mass  $m$  and specific heat capacity  $c$  is calculated from the formula  $Q = m c \Delta t$ . According to the formula  $t = Q/P$ , the heat required  $Q$  must be divided by the energy  $P$  with which the object is heated to obtain the required heating time  $t$ . It is obvious that this heating time can also be determined experimentally.

**[0051]** In the case of electric heating, for example an electric heating element is placed against the glass tube.

In order to activate the actuator, an electric current is passed through the heating element, so that it heats up very quickly and the glass tube quickly reaches the rupture temperature.

**[0052]** In the case of a heat source for which the heat is obtained by burning a gas, the breaking device comprises a reservoir in which butane, propane or some other flammable gas is stored under a pressure of at least 10 bar, preferably not more than 20 bar. This reservoir has a discharge orifice which is closed with a shut-off valve that is operable by means of an electromagnet (an electromagnetically operable shut-off valve is also called a solenoid valve hereinafter) wherein the discharge orifice is located in the vicinity of the glass tube. An ignition element is provided in the vicinity of the discharge orifice, with which a spark can be formed by means of an electric current.

**[0053]** Activation of the actuator firstly involves the discharge orifice of the reservoir being opened by operation of the solenoid valve, and immediately thereafter, after a time interval that roughly coincides with the time the gas takes to reach the discharge orifice, a voltage is applied between two conductors of the ignition element so that a spark is generated, which causes the gas to ignite. For a certain period, in this way a spark is formed repeatedly in the ignition element with a time interval as short as possible to guarantee ignition of the gas.

**[0054]** The amount of gas in the reservoir is sufficient to bring the glass tube located next to the discharge orifice, by means of the burning gas, to a temperature that is equal to or higher than the rupture temperature. In the reservoir, preferably a mixture of gas and oxygen is provided, with a mixing ratio such that the gas burns immediately and intensely and quickly reaches its maximum temperature. Generally this is a temperature above 1000°C, thus ensuring that the glass tube will break quickly.

**[0055]** Alternatively, the gas might also not be mixed with oxygen beforehand, so that less complete combustion takes place. With this combustion, however, a temperature of 500°C is still easily reached.

**[0056]** When the glass tube is broken and the extinguishing agent is distributed, the flame of the burning gas of the breaking device is therefore extinguished automatically and the reservoir is then emptied. The small amount of gas released thereby does not present any danger.

**[0057]** Another option is that the reservoir is opened and the discharge orifice is closed again after a predetermined time, wherein the time during which the reservoir is open is sufficient to heat the glass tube sufficiently with the burning gas to break the glass tube. This prevents the residual unburnt gas from flowing out of the reservoir. Reclosing of the discharge orifice can also be controlled by means of a signal received from a sensor, for example from a sensor, e.g. a water sensor, that detects whether the extinguishing device is operating and closes the discharge orifice of the reservoir after the presence of water or another extinguishing agent has been

detected.

**[0058]** According to another embodiment, the breaking device of the actuator comprises a reservoir with a gas or a liquid under high pressure with a discharge orifice that can be opened or closed by means of a shut-off valve. The shut-off valve may be operated by means of an electromagnet. To activate the actuator, a current is passed through the electromagnet so that the shut-off valve is brought very quickly to an open position. This takes place so quickly that a powerful gas stream leaves the reservoir via the discharge orifice. This powerful gas stream is directed onto the glass tube, so that a pressure is exerted on this glass tube that is sufficient to break the glass tube.

**[0059]** According to a fourth aspect of the present invention, a modular sensor is provided.

**[0060]** The monitoring of parameters in the human living and work environment is known. This may for example involve parameters relating to air quality such as temperature, humidity, CO content or the presence of gases that may be injurious to health, or parameters relating to fire safety, e.g. the aforementioned fire parameters or parameters relating to protection against burglary or theft, for example movement, or the breaking of glass. Other parameters, for example such as the open or closed state of a window or door or the energy consumption in a particular room or in a particular building may be monitored.

**[0061]** Various standardized sensors and detectors are available for detecting all these parameters.

**[0062]** For certain applications, multifunctional detection units, tailor-made for the user, are developed, which comprise a number of detectors or sensors with a respective function, and associated components and a suitable housing. These detection units are developed in each case for a well-defined combination of sensor functions, and this is time-consuming and expensive.

**[0063]** In order to overcome this drawback, the present invention provides a modular sensor, comprising a sensor base and at least two sensor modules that are suitable for detecting respective mutually different parameters, wherein each sensor module can be connected to the sensor base to form a sensor unit, optionally with the desired sensor function(s).

**[0064]** The expression 'modular sensor' is used in this patent application in the meaning of a number of available sensor components, from which a sensor with the desired sensor functions can be assembled.

**[0065]** According to the fourth aspect of the invention, a fire protection device is also provided, which comprises a sensor unit of modular assembly, assembled by selecting one or more desired sensor modules from a number of sensor modules that are offered or are available.

**[0066]** This fire protection device may be any fire protection device, but is in particular the fire protection device that is described above with reference to the first and the third aspect of the present invention.

**[0067]** Two sensors or two sensor modules that are

designed to detect a mutually different parameter are also indicated in this patent application as sensors or sensor modules with a different sensor function.

**[0068]** In a preferred embodiment, this fire protection device comprises a sensor unit that is assembled from a set of sensor components comprising a sensor base with at least one sensor position for placement of a sensor module, and at least two sensor modules that are suitable for detecting respective mutually different parameters, wherein each sensor module can be connected to the sensor base to form a sensor unit, optionally with the desired sensor function(s).

**[0069]** With a modular sensor according to the fourth aspect of the present invention, a user may himself assemble or modify a sensor unit in order to monitor the desired parameter or parameter set. Thus, users are offered a 'drag and drop' modularity, wherein they themselves can assemble a sensor unit with the desired parametric function(s). Thus, for example, a sensor unit may be assembled that monitors the air humidity and the CO<sub>2</sub> concentration of the ambient air. However, with the same sensor base, the user may also assemble a sensor unit that detects both movement and the exceeding of a threshold concentration of CO in a particular room. If desired, the user may also add for example detection of a certain temperature being exceeded, or detection that smoke is present in the room that is being monitored. A sensor unit may be assembled that has each possible sensor function or monitors each possible combination of two or more parameters. The developer and manufacturer has the advantage that developments and adjustments take less time. In addition, it is also easy to replace a faulty sensor module, so that repairs and maintenance proceed more easily.

**[0070]** Preferably at least one sensor position is provided on the sensor base. In a preferred embodiment, at least two sensor positions are provided, preferably two, three or four sensor positions. At each sensor position, an identical first connector is provided, whereas each sensor module comprises a second connector that is designed to interact with said first connector at each sensor position of the sensor base.

**[0071]** The modular sensor according to the present invention preferably comprises at least two different sensor bases, which have a different number of sensor positions respectively.

**[0072]** Each sensor base of the modular sensor according to the present invention preferably comprises a printed circuit board (PCB) provided with a first connecting means for connecting to a power source and a second connecting means for connecting to a data communication means. Data communication takes place for example via an I<sup>2</sup>C bus, a synchronous, serial bus developed for data communication between microprocessors and other ICs.

**[0073]** The modular sensor according to the present invention preferably also comprises at least two different housings, which are adapted to different sensor func-

tions. Thus, a first housing may be provided with mainly closed walls that enclose the components, and/or a second housing, at least one wall of which is perforated for assembling a sensor unit, for which at least one of the sensor modules fitted on the sensor base is designed to monitor a parameter of the ambient air, for example the presence of a particular gas, and/or a third housing with at least one wall in which an opening is provided in which a lens is placed for assembling a sensor unit, for which at least one of the sensor modules fitted on the sensor base comprises a light sensor.

**[0074]** The modular sensor according to the present invention preferably also comprises at least two different battery modules with a mutually different power and/or different capacity. Thus, the user may also select the battery that has, among other things depending on the selected sensor modules, the frequency with which the software checks whether new data are available ('polling rate') and the type of antenna, the desired discharge time and/or the desired life.

**[0075]** Each sensor module is preferably provided on a printed circuit board with smaller dimensions than the printed circuit board of the sensor base and comprises a second connector that is complementary to the first connector on the printed circuit board of the sensor base. Each sensor module has dimensions such that it fits within the free space that is provided at each sensor position.

**[0076]** The selected sensor module is coupled to the sensor base by coupling the first connector to the sensor base and the second connector to the sensor module. The coupling between these first and second connectors may for example be provided by means of a simple click connection.

**[0077]** Because each sensor has a unique address, the data processing means that interact with a sensor unit recognize which type of sensor is located at each sensor position of the sensor base, and the data received therefrom can be processed and interpreted correctly. This by for example making use of a protocol, such as I<sup>2</sup>C with '10-bit addressing', so that just under 1023 addresses are available for identifying the various sensors.

**[0078]** According to a fifth aspect of the present invention, a detector is provided that is designed to detect the presence of one or more harmful substances in the air.

**[0079]** According to this fifth aspect of the invention, a fire protection device is also provided, which comprises a detector that is designed to detect the presence of one or more harmful substances in the air.

**[0080]** This fire protection device may be any fire protection device, but is in particular the fire protection device that is described above with reference to the first, third or fourth aspect of the present invention.

**[0081]** Preferably, the fire protection device, in particular the detector itself, is designed to evaluate the harmfulness of the substances present in the air.

**[0082]** The term 'air' is used here in the sense of the air (as a gas mixture) that is present in the environment of the detector. The substances present in the air are all

substances that are mixed with said air or are taken up therein, regardless of their state. Thus, these substances may be present in the air in the form of gases or vapours or as constituents of smoke or in the form of a mist or as airborne solid particles.

**[0083]** Determination of the harmfulness of the substances present in the air is for example based on the nature of the substances detected, whether or not in combination with a parameter relating to the concentration of the detected material in the air. A possible parameter with regard to the concentration of a detected material is the indication whether or not a certain threshold concentration of the material in the air is exceeded. Based on the nature of the substances detected, optionally also taking into account a parameter relating to their concentration or their measured or established concentration, for example two or more degrees of harmfulness may be determined.

**[0084]** On detection of smoke in a protected room, the detector according to the invention is for example designed to detect whether the air contains one or more predetermined harmful gases, and to evaluate the harmfulness of the smoke on the basis of this information. This evaluation checks for example whether the smoke is harmful and for example has been produced by a fire, or is less harmful and for example has come from a cigarette, or is harmless and for example is produced by a smoke machine.

**[0085]** This information supplied by the fire protection device concerning the harmfulness of the substances present in the air can be used for deciding, according to a previously established decision criterion, whether or not action must be taken, and if so, what action.

**[0086]** If, in the information supplied about the harmfulness, for example a distinction is made between class A: very harmful, class B: harmful and class C: harmless, according to a possible decision criterion it may for example be stipulated that on detection of a material of class A by one or more sensors, the fire brigade must be informed immediately, that on detection of a material of class B by two or more sensors, a responsible service or person is informed, for example such as the caretaker of a building, and that on detection of a material of class B by only one detector, only the occupant or the owner of the building is informed.

**[0087]** The fire protection device is for example designed to use the evaluation of the harmfulness of the substances present in the air to determine according to an automatically proceeding, predetermined decision model, whether a predetermined notification action or alarm action must be undertaken, and if applicable carry out a prescribed notification action or alarm action associated with the established harmfulness.

**[0088]** The detector according to the present invention is for example equipped with one or more sensors that are able to detect respective different constituents of a gas. The gas is therefore analysed. A number of technologies are available for this: gas chromatography, pho-

to-acoustic spectroscopy, non-dispersive infrared spectroscopy, etc.; other electrochemical technologies, photo-ionization or other gas detection sensors are also possible.

**[0089]** These existing techniques may also be used for detecting a number of different constituents of smoke.

**[0090]** A number of flue gases which among others are usually present in the smoke that is produced in a fire are listed hereunder. The more of these flue gases and other substances are detected, the more accurate the report of the fire will be.

**[0091]** With complete combustion, usually the following flue gases are released:  $\text{NO}_x$  at high temperatures, sulphur compounds such as  $\text{SO}_2$ , and  $\text{CO}_2$ .

**[0092]** In fires, however, more often incomplete combustion takes place. This also leads to a larger number of harmful gases. Certainly as a fire spreads more, combustion becomes less and less complete. In incomplete combustion, usually the following flue gases are released: CO, HCN (particularly dangerous),  $\text{NH}_3$  and typically  $\text{NO}_x$  owing to the presence of nitrogen-containing materials, HCl,  $\text{COCl}_2$  (phosgene), dioxins, chloromethane,  $\text{CH}_3\text{Br}$  owing to the presence of halogens, e.g. chlorine (present in plastics and fire retardants), HF, a substance that is very poisonous on inhalation starting from 3ppm owing to the presence of fluorocarbons; phosphorus and antimony oxides result from reactions of some fire retardants and increase the toxicity of the smoke.

**[0093]** The pyrolysis of PCBs (e.g. present in transformer oil of electrical installations and capacitors), e.g. in a fire in an office in which old computers catch fire, also leads to the formation of strong carcinogens (2,3,7,8-tetrachlorodibenzo-p-dioxin) and other PCDDs. The pyrolysis of fluoropolymers, e.g. Teflon and other PTFEs, also leads to carbonyl fluoride and once again to HF and  $\text{CO}_2$ , but also other highly toxic substances.

**[0094]** Moreover, pyrolysis of flammable material during incomplete combustion leads to hydrocarbons, both aliphatic and aromatic. Studies also demonstrate carcinogenic action of these substances. Heavier hydrocarbons are reduced to tar in smoke and in the long term are also very unhealthy for the respiratory tract. Moreover, a high concentration of these may lead to an increased likelihood of flashover and backdraft (a smothered fire through lack of oxygen), two very dangerous situations. By installing a detector according to the invention, the fire brigade can be provided with the information that enables them to assess this risk beforehand, even before they enter the burning room to begin the extinguishing activities. Also, with incomplete combustion, the presence of sulphur-containing substances leads to the formation of sulphur compounds such as  $\text{SO}_2$ , but also  $\text{H}_2\text{S}$ , OCS,  $\text{CS}_2$  and thiols.

**[0095]** The fire protection device according to this fifth aspect of the invention preferably comprises a detector that is equipped with at least one sensor that is designed to determine the concentration of a particular gas in the air, for example such as the  $\text{CO}_2$  concentration or the

CO concentration, in the air. The gases detected are not in themselves necessarily harmful or associated with a fire.

**[0096]** By determining or monitoring the concentration of certain gases in the air, a number of parameters relating to air quality can be checked or monitored, for example such as the  $\text{CO}_2$  concentration and the CO concentration in the air. This gives a picture of the quality of the inhaled air in a particular room, which is of course useful information for the health of the people who remain in said room. This may allow timely intervention, for example with better ventilation of the room.

**[0097]** In a fire, the detection of harmful substances, optionally supplemented with their concentration, can provide information that is useful for estimating the harmfulness and danger of the situation. This information may in addition also help to determine what type of fire we are dealing with, and the seriousness or the size or the nature of the burning products or objects.

**[0098]** In addition, the results of this analysis may also be used for establishing which harmful substances each victim of a fire has been exposed to and how long this exposure lasted. This information may be useful for determining what medication and/or what medical treatment is the most suitable for each victim. It has been shown that nearly 50% of the fatal victims in a fire die as a result of exposure to the combustion products.

**[0099]** Also in places where smoking is prohibited, for example such as in hotels or in rooms where flammable materials are stored, information about the presence of certain substances may be useful for deducing what precisely is burning, so that appropriate action can be taken. The fire brigade should not be called out for a guest who is smoking in a hotel room.

**[0100]** The present invention is now explained in more detail on the basis of the following detailed description of a number of preferred devices according to the invention. The purpose of this description is exclusively to give an explanatory example and to indicate further advantages and features of the present invention, and accordingly should not in any way be interpreted as a limitation of the scope of the invention according to the patent rights claimed in the claims, or of the field of application thereof.

**[0101]** In this detailed description, reference numbers are used for referring to the appended drawings, where

- Fig. 1 presents a side view of a separate extinguishing unit according to the present invention,
- Fig. 2a is a schematic representation of a sprinkler actuator with a mechanically acting breaking device,
- Fig. 2b is a schematic representation of the drive part of the breaking device of the actuator in Fig. 2a,
- Fig. 3 is a schematic representation of a sprinkler actuator with a thermally acting breaking device provided with an electric heat source,

- Fig. 4 is a schematic representation of a sprinkler actuator with a thermally acting breaking device provided with a gas heat source,
- Fig. 5 is a schematic representation of a sprinkler actuator with a breaking device designed to be broken by means of a gas stream,
- Fig. 6a is a schematic representation of a top view of a printed circuit board of a sensor base of a modular sensor unit according to the present invention, and
- Fig. 6b is a schematic representation of a top view of a printed circuit board of a sensor module of a modular sensor unit according to the present invention.

**[0102]** In a preferred embodiment, the fire protection device according to the present invention comprises an extinguishing unit (see Fig. 1) consisting of a metal extinguishing agent reservoir (1) that has a nozzle at the bottom, whereas a sprinkler head (2) is mounted opposite the nozzle.

**[0103]** On the upper edge of the reservoir (1), a bracket (3) is fastened, in which screw holes are provided so that the extinguishing unit can be fastened by means of screws (4) to the ceiling of a room.

**[0104]** In this extinguishing agent reservoir (1), an extinguishing agent is provided at a pressure of 6 bar. The extinguishing agent is water that has been treated to make it non-conductive, mixed with a fluorine-free extinguishing foam with a concentration of 10% relative to the water.

**[0105]** The sprinkler head (2) comprises a glass tube (2a), which closes the nozzle. In the glass tube, which is a closed glass bulb, there is a liquid, the volume of which increases on heating to about 67°C so that the glass tube (2a) breaks, and the nozzle is released, and extinguishing agent is distributed over the space around the extinguishing unit.

**[0106]** The sprinkler head (2) is of a generally known type that has, centrally under the nozzle, a disk-shaped plate (2b), with a shape such that extinguishing agent is distributed around the extinguishing unit and completely covers the surface area of the room protected thereby.

**[0107]** An extinguishing unit of this kind is fastened to the ceiling in each room of a building. In this way, each room is protected against fire by an independently operating extinguishing unit with its own supply of extinguishing agent.

**[0108]** In the case of a room that is protected against fire by an existing sprinkler installation with a sprinkler head (2) of the type that comprises a breakable activation element (2a), the sprinkler head (2) according to the present invention may then be used as a separate extinguishing unit, which is activatable by some other activating device or by some other detection device.

**[0109]** For this purpose (see Figs. 2a, 2b, 3, 4 and 5), an actuator (10), (20), (30), (40) is provided in the vicinity of an existing sprinkler head (2), said actuator comprising a communication module (11), (21), (31), (41) and a battery module (12), (22), (32), (42) and a breaking device (13), (23), (33), (43). The communication module can operate at various frequencies, preferably in the standard band 868 MHz or 433 MHz. The battery is replaceable and may have various capacities.

**[0110]** The breaking device (13), (23), (33), (43), a number of different embodiments of which are described in more detail hereunder, is designed to break the glass tube (2a) of the sprinkler head (2), when the actuator is activated via the communication module (11), (21), (31) by a detection signal that is generated by another detection device. This other detection device is for example a detector unit with several sensors, for example such as a detector unit that is designed to detect the presence of certain gases associated with a fire.

**[0111]** In a first possible embodiment (Figs. 2a and 2b), the breaking device (13) comprises a metal pin (14) that is movable in its longitudinal direction in a case (15). The pin (14) is located with a tail portion between two gears (16), (17). The tail portion of the pin (14) is provided with engaging means (not shown) so that by turning the gears (16), (17) in mutually opposite directions of rotation, the pin (14) is moved in the case (15) from the starting position shown in Fig. 2b towards the glass tube (2a), until the end of the pin (14) strikes at high speed against the glass tube (2a), so that the glass tube (2a) is broken. By changing the directions of rotation of the gears (16), (17), the pin (14) can be moved in the opposite direction of motion back to the starting position. Each gear (16), (17) is driven by a respective motor (not shown).

**[0112]** In a second possible embodiment (Fig. 3), the breaking device (23) — shown very schematically in Fig. 3 — comprises an electric heating element (24) that is placed very close to or against the glass tube (2a). In order to activate the actuator (20), an electric current is passed through the heating element (24), so that the heating element (24) is heated very quickly, quickly bringing the glass tube (2a) up to its rupture temperature.

**[0113]** In a third possible embodiment (Fig. 4), the breaking device (33) comprises a gas reservoir (34), in which an easily and quickly flammable gas mixture, such as a mixture of propane and oxygen, is stored at a pressure of 15 bar. This gas mixture quickly reaches a temperature of about 1000°C. The gas reservoir (34) has a discharge orifice (35) in the vicinity of the glass tube (2a). An ignition element (not shown), with which a spark can be formed by means of an electric current, is placed in the vicinity of this discharge orifice (35). The discharge orifice (35) is closed with a shut-off valve (not shown), which is operable by means of an electromagnet.

**[0114]** Activation of the actuator firstly involves the discharge orifice (35) of the gas reservoir (34) being opened by operation of the solenoid valve, and then a voltage being applied immediately between two conductors of

the ignition element so that a spark is generated, which causes the gas to ignite. The amount of gas mixture in the reservoir (34) is sufficient for the glass tube (2a) to be heated quickly to the rupture temperature by means of the burning gas.

**[0115]** When the glass tube is broken and the extinguishing agent is distributed from the extinguishing agent reservoir, the flame of the burning gas from the breaking device is therefore automatically extinguished and the gas reservoir (34) is emptied.

**[0116]** In a fourth possible embodiment (Fig. 5), the breaking device (43) comprises a gas reservoir (44) in which a harmless gas is stored at high pressure. The gas reservoir (44) has a discharge orifice (45) that can be opened or closed by means of an electromagnetically operable shut-off valve. For activating the actuator, the shut-off valve is brought very quickly to an open position, so that a powerful gas stream leaves the gas reservoir (44) via the discharge orifice (45). This powerful gas stream is directed onto the glass tube (2a), so that a pressure is exerted on this glass tube (2a) that is sufficient to break it.

**[0117]** The present invention also provides a modular sensor unit that is assembled from a sensor base and a number of sensor modules. Fig. 6a shows a top view of the printed circuit board (50) of a sensor base, while Fig. 6b shows the printed circuit board (60) of a sensor module in top view.

**[0118]** The sensor unit is assembled according to the user's wishes or the conditions in the room to be protected, wherein a choice is made from a number of different sensor modules with mutually different sensor functions, in other words sensor modules whose sensors or detectors are provided for detecting mutually different parameters.

**[0119]** These parameters may relate to air quality such as temperature, humidity, CO content or the presence of gases that may be injurious to health, or may relate to fire safety, e.g. parameters that are associated with a fire or an incipient fire, such as the presence of certain gases or smoke or a quick temperature rise, or parameters relating to protection against burglary or theft, for example movement, or breaking of glass. Other parameters, for example such as the open or closed state of a window or a door or the energy consumption in a particular room or in a particular building, may also be monitored by means of a sensor module according to the present invention.

**[0120]** In a preferred embodiment, a modular sensor comprises a sensor base with a printed circuit board (50) on which four sensor positions (51)-(54) are provided. The printed circuit board also comprises a battery module (55) and an antenna (56). Data communication takes place for example via an I<sup>2</sup>C bus.

**[0121]** At each sensor position (51)-(54), a connector (51a)-(54a) is provided that is compatible with the standard connector (61) on each sensor module. These, four sensor modules may be selected from a number of avail-

able sensor modules. Only one of these sensor modules is shown in Fig. 6b. The selected sensor modules may be placed in a selected respective sensor position (51)-(54) on the printed circuit board (50) and may be connected via the connectors (51a)-(54a) to the other components (55), (56) of the sensor unit.

**[0122]** Each sensor module comprises a printed circuit board (60) with smaller dimensions than the printed circuit board (50) of the sensor base. Besides a number of peripheral components that are not shown, a sensor (62) and a standard connector (61) connected to this sensor (62) are provided on this printed circuit board (60). This standard connector (61) is complementary to each of the four connectors (51a)-(54a) that are provided on the printed circuit board (50) of the sensor base. It is to be noted that the printed circuit board (60) shown in Fig. 2b is shown enlarged, so that its dimensions do not have the correct proportions relative to the printed circuit board (50) of the sensor base in Fig. 2a. Of course, each sensor module has dimensions such that it fits in the free space that is provided at each sensor position (51)-(54) on the printed circuit board (50) of the sensor base.

**[0123]** Each of the four selected sensor modules is connected to the sensor base by coupling the connector (61) to the connector (51a)-(54a) at a free sensor position. Coupling takes place by means of a click connection.

**[0124]** Because each sensor has a unique address, the data processing means that interact with the sensor unit recognize which type of sensor module is located at each sensor position (51)-(54), and the data received therefrom can be processed and interpreted correctly.

**[0125]** The modular sensor also comprises three different housings (not shown in the figures), which are adapted to the possible sensor functions. The first housing comprises mainly closed walls, which enclose the components almost completely, the second housing has perforated walls in order to ensure proper action of a sensor module that is designed to detect the presence of a particular gas, and the third housing has closed walls except for one wall, in which an opening is provided in which a lens is placed in order to ensure the correct action of a sensor module that comprises a light sensor.

**[0126]** The modular sensor according to the present invention also comprises two different battery modules (55) with a mutually different power and a different capacity. Therefore the user can choose the most suitable battery for the sensor unit that he has assembled.

## Claims

1. Fire protection device for protecting at least one room, comprising a detection device for detecting one or more fire parameters, and an extinguishing device that is provided for delivering an extinguishing agent into each protected room, wherein the detection device is provided for activating the extinguishing device in a room on detection of at least one fire

- parameter, **characterized in that**, in each protected room, an extinguishing unit (1, 2, 3) is provided that comprises a reservoir (1) in which a quantity of extinguishing agent is provided, and which, on detection of at least one fire parameter, is designed to bring extinguishing agent from the reservoir (2) into said room.
2. Fire protection device according to Claim 1, **characterized in that** the fire protection device protects at least two rooms.
  3. Fire protection device according to Claim 1 or 2, **characterized in that** each extinguishing unit (1, 2, 3) comprises, connected to the reservoir (1), an extinguishing head (2) with an opening via which extinguishing agent can be brought from the reservoir (1) into the protected room.
  4. Fire protection device according to Claim 1 or 2, **characterized in that** the extinguishing agent is provided under pressure in the reservoir (1).
  5. Fire protection device according to Claim 3 or 4, **characterized in that** each extinguishing unit (1, 2, 3) comprises a spraying element (2b) for distributing the extinguishing agent in the environment of the reservoir after it leaves the reservoir.
  6. Extinguishing unit (1, 2, 3) for protecting a room against fire, **characterized in that** it comprises,
    - a reservoir (1) that is designed to provide a quantity of extinguishing agent,
    - an extinguishing head (2), connected to the reservoir (1), with a discharge orifice for bringing extinguishing agent from the reservoir (1) into the protected room, and
    - a detection and activation device that is arranged to open the discharge orifice of the extinguishing head on detection of one or more fire parameters,
  7. Set of extinguishing units for protecting a number of rooms against fire, **characterized in that** it comprises a number of extinguishing units (1, 2, 3) according to the preceding claim, and **in that** each extinguishing unit (1, 2, 3) is designed to be placed in a different room to be protected.
  8. Extinguishing agent for an extinguishing unit according to Claim 6 or 7, **characterized in that** it is a base extinguishing agent, to which at least one additive is added that comprises a plant extract and/or a mineral salt of an acid.
  9. Extinguishing agent according to Claim 8, **characterized in that** at least one additive added is in itself an extinguishing foam.
  10. Extinguishing agent according to Claim 9, **characterized in that** at least one additive added is an ecological telomer-based foam, or a fluorine-free foam or a foam that is a mixture of water, air and a wetting agent.
  11. Extinguishing agent according to one of Claims 8 to 10, **characterized in that** each additive is added with a mixing ratio from 1.5% to 15% relative to the base extinguishing agent.
  12. Extinguishing agent according to one of Claims 8 to 11, **characterized in that** the base extinguishing agent has undergone a treatment, so that it has a reduced conductivity or is non-conductive.
  13. Fire protection device according to one of Claims 1 to 5, **characterized in that** it comprises a breakable activation or detection element (2a) for activating an alarm device or an extinguishing device, and an actuator (10), (20), (30), (40) that is designed to break the breakable activation or detection element (2a), wherein the actuator (10), (20), (30), (40) is activatable by other activating means or detecting means.
  14. Fire protection device according to Claim 13, **characterized in that** the actuator (10), (20), (30), (40) comprises a breaking device (13) that comprises either a movable breaking means (14) in order to break the breakable activation or detection element (2a) through mechanical contact with the breaking means (14), or comprises heating means (24), (34, 35) in order to heat the breakable activation or detection element (2a) until it breaks, or comprises means (44, 45) for creating a gas stream or liquid stream directed onto the breakable activation or detection element (2a) in order to break it.
  15. Fire protection device according to Claims 13 or 14, **characterized in that** the actuator (10), (20), (30), (40) is fastened on or against a breakable activation element (2a) of a sprinkler head (2) of a sprinkler installation and is designed to break the breakable activation element (2a).
  16. Fire protection device according to one of Claims 1 to 5 or according to one of Claims 13 to 15, **characterized in that** this device comprises a sensor unit that is of modular assembly by selecting one or more desired sensor modules from a number of available sensor modules.
  17. Fire protection device according to Claim 16, **characterized in that** the modular sensor unit is assembled from a set of sensor components comprising

- a sensor base with at least one sensor position (51)-(54) for placement of a sensor module, and  
 - at least two sensor modules that are suitable for detecting respective mutually different parameters,

wherein each sensor module can be connected to the sensor base to form a sensor unit, optionally with the desired sensor function(s).

- 18. Fire protection device according to Claim 17, **characterized in that** at least two sensor positions (51)-(54) are provided on the sensor base.
- 19. Fire protection device according to Claim 17 or 18, **characterized in that** an identical first connector (51a)-(54a) is provided at each sensor position (51)-(54), whereas each sensor module comprises a second connector (61) that is designed to interact with said first connector (51a)-(54a) at each sensor position (51)-(54) of the sensor base.
- 20. Fire protection device according to one of Claims 17 to 19, **characterized in that** the set of sensor components comprises at least two different sensor bases, which have a different number of sensor positions (51)-(54).
- 21. Fire protection device according to one of Claims 17 to 20, **characterized in that** the set of sensor components comprises at least two different housings, which are adapted to different sensor functions.
- 22. Fire protection device according to one of Claims 17 to 21, **characterized in that** the set of sensor components comprises at least two different battery modules (55) with a mutually different power and/or different capacity.
- 23. Fire protection device according to one of Claims 16 to 22, **characterized in that** each sensor base comprises a printed circuit board (50) that is provided with a first connecting means for connecting to a power source and a second connecting means for connecting to a data communication means.
- 24. Fire protection device according to one of Claims 1 to 5 or according to one of Claims 13 to 23, **characterized in that** this fire protection device comprises a sensor or a detector that is designed to detect the presence of one or more substances in the air.
- 25. Fire protection device according to Claim 24, **characterized in that** it is designed to evaluate the harmfulness of the substances present in the air.
- 26. Fire protection device according to Claims 24 or 25, **characterized in that** the harmfulness of the sub-

5

10

15

20

25

30

35

40

45

50

55

stances present in the air is determined on the basis of the nature of the detected substances in combination with a parameter relating to the concentration of the detected material in the air.

- 27. Fire protection device according to one of Claims 24 to 26, **characterized in that** the detector is designed to detect the presence of one or more harmful gases in smoke, and to evaluate the harmfulness of the smoke on the basis of this information.
- 28. Fire protection device according to one of Claims 25 to 27, **characterized in that** the evaluation of the harmfulness of the substances present in the air is used in order to determine according to an automatically proceeding decision model whether a predetermined notification action or alarm action must be taken, and if applicable to carry out a prescribed notification action or alarm action associated with the established harmfulness.
- 29. Fire protection device according to one of Claims 24 to 28, **characterized in that** the detector is equipped with at least one sensor that is designed to determine the concentration of a particular gas in the air, for example such as the CO<sub>2</sub> concentration or the CO concentration in the air.

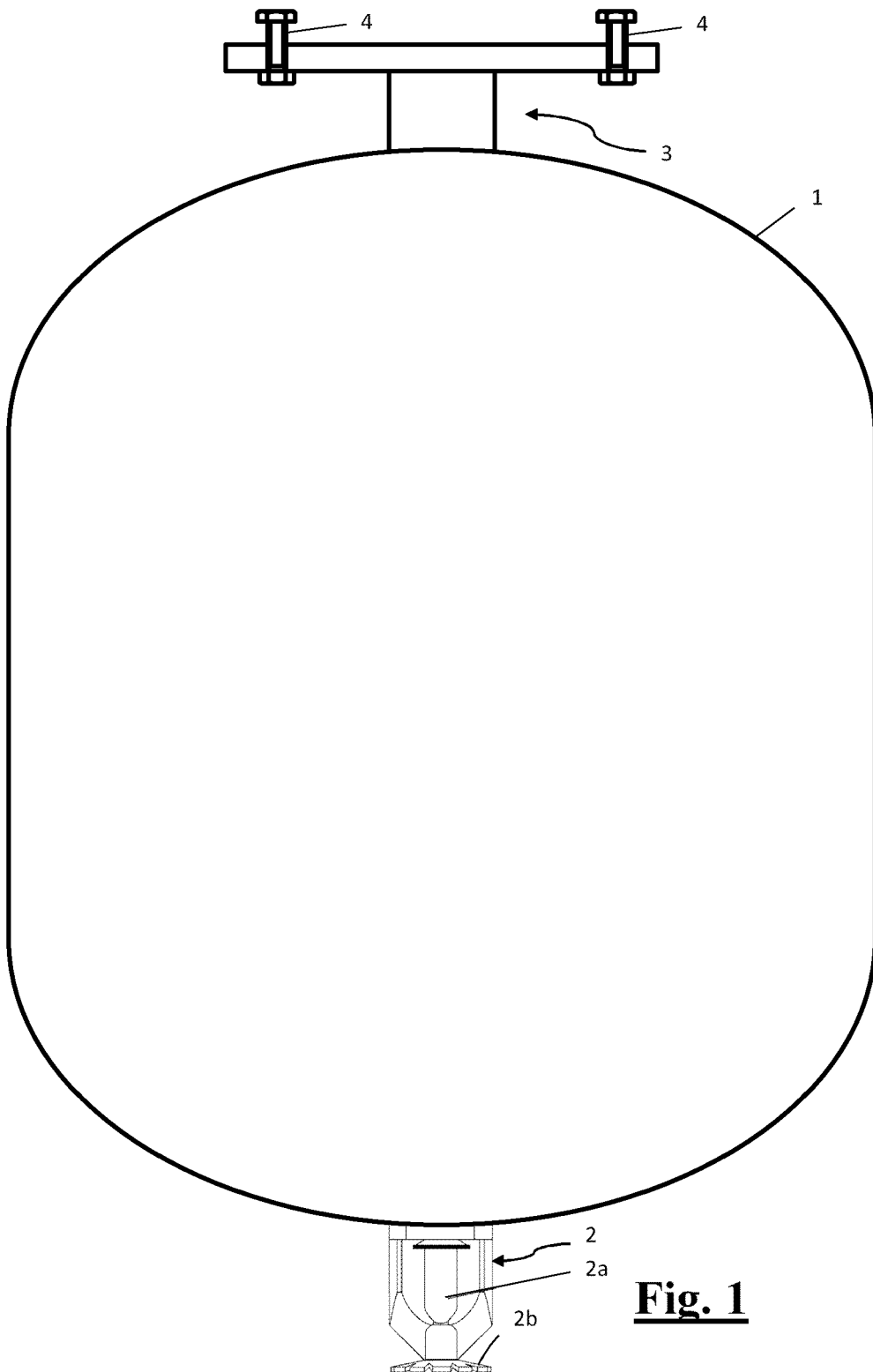

**Fig. 1**

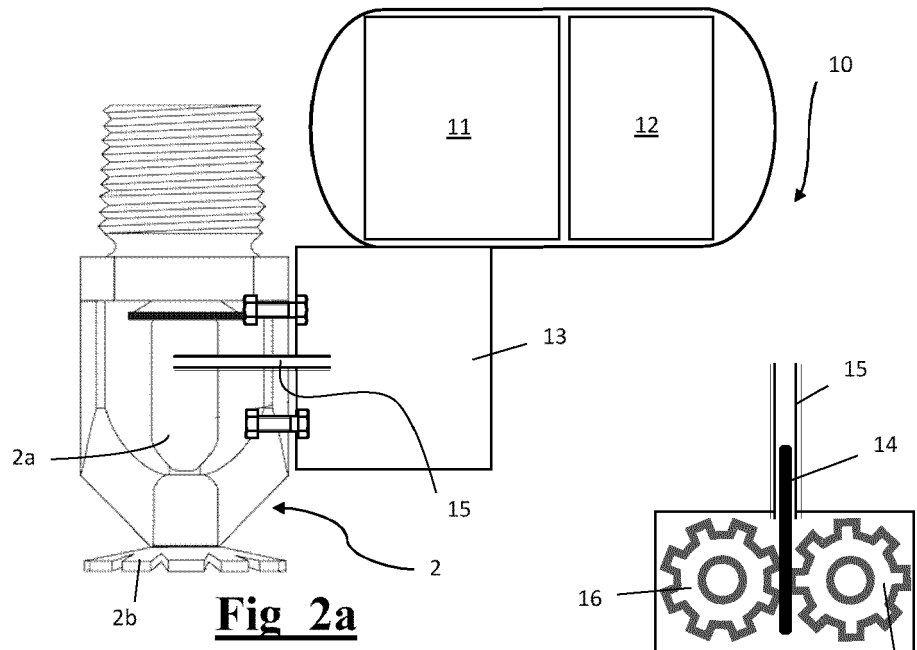

**Fig 2a**

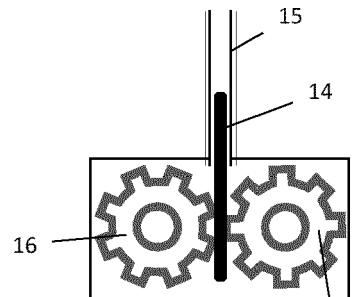

**Fig 2b**

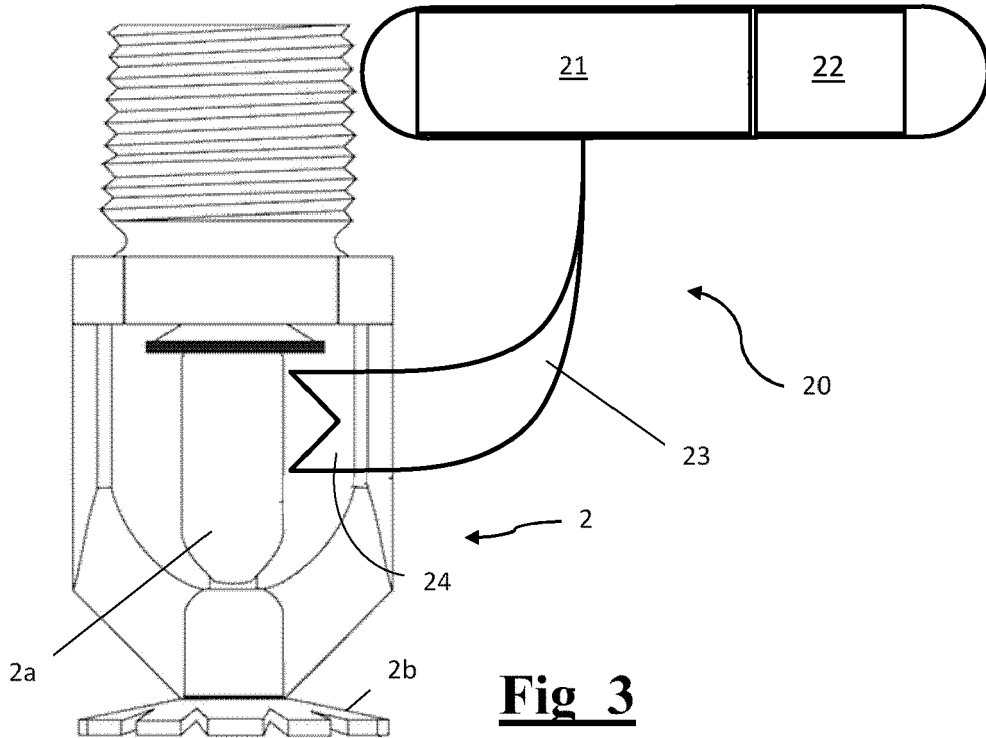

**Fig 3**

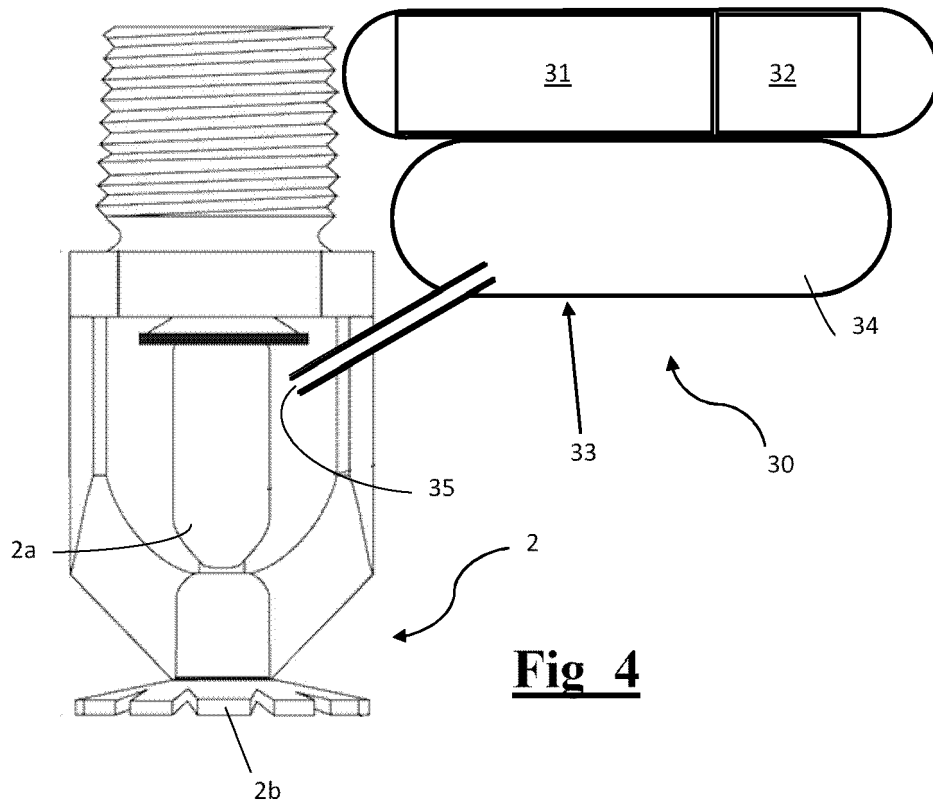

**Fig 4**

