



(12) **DEMANDE DE BREVET CANADIEN
CANADIAN PATENT APPLICATION**

(13) **A1**

(86) Date de dépôt PCT/PCT Filing Date: 2019/08/16
(87) Date publication PCT/PCT Publication Date: 2020/02/20
(85) Entrée phase nationale/National Entry: 2021/02/15
(86) N° demande PCT/PCT Application No.: US 2019/046958
(87) N° publication PCT/PCT Publication No.: 2020/037296
(30) Priorités/Priorities: 2018/08/17 (US16/104,758);
2018/11/09 (US62/758,110); 2019/02/05 (US62/801,587);
2019/04/09 (US62/831,666); 2019/04/09 (US62/831,646);
2019/04/09 (US62/831,600); 2019/04/09 (US62/831,657);
2019/07/01 (US16/459,388)

(51) Cl.Int./Int.Cl. *A23G 9/08* (2006.01),
A23G 9/10 (2006.01), *A23G 9/22* (2006.01),
A23G 9/28 (2006.01), *B65D 85/78* (2006.01)
(71) Demandeur/Applicant:
SIGMA PHASE, CORP., US
(72) Inventeurs/Inventors:
FONTE, MATTHEW, US;
HEYMANS, JOHN, US;
FICHERA, BENJAMIN, US;
HUGENROTH, JASON, US
(74) Agent: SMART & BIGGAR LLP

(54) Titre : FOURNITURE DE PORTIONS INDIVIDUELLES D'ALIMENTS ET DE BOISSONS REFROIDIS
(54) Title: PROVIDING SINGLE SERVINGS OF COOLED FOODS AND DRINKS

(57) **Abrégé/Abstract:**

Systems and methods have demonstrated the capability of rapidly cooling the contents of pods containing the ingredients for food and drinks.

(12) INTERNATIONAL APPLICATION PUBLISHED UNDER THE PATENT COOPERATION TREATY (PCT)

(19) World Intellectual Property
Organization
International Bureau



(10) International Publication Number
WO 2020/037296 A1

(43) International Publication Date
20 February 2020 (20.02.2020)

(51) International Patent Classification:

A23G 9/08 (2006.01) *A23G 9/10* (2006.01)
A23G 9/22 (2006.01) *B65D 85/78* (2006.01)
A23G 9/28 (2006.01)

EE, ES, FI, FR, GB, GR, HR, HU, IE, IS, IT, LT, LU, LV,
MC, MK, MT, NL, NO, PL, PT, RO, RS, SE, SI, SK, SM,
TR), OAPI (BF, BJ, CF, CG, CI, CM, GA, GN, GQ, GW,
KM, ML, MR, NE, SN, TD, TG).

(21) International Application Number:

PCT/US2019/046958

Declarations under Rule 4.17:

- as to applicant's entitlement to apply for and be granted a patent (Rule 4.17(ii))
- as to the applicant's entitlement to claim the priority of the earlier application (Rule 4.17(iii))

(22) International Filing Date:

16 August 2019 (16.08.2019)

(25) Filing Language:

English

(26) Publication Language:

English

Published:

- with international search report (Art. 21(3))
- before the expiration of the time limit for amending the claims and to be republished in the event of receipt of amendments (Rule 48.2(h))

(30) Priority Data:

16/104,758	17 August 2018 (17.08.2018)	US
62/758,110	09 November 2018 (09.11.2018)	US
62/801,587	05 February 2019 (05.02.2019)	US
62/831,666	09 April 2019 (09.04.2019)	US
62/831,657	09 April 2019 (09.04.2019)	US
62/831,600	09 April 2019 (09.04.2019)	US
62/831,646	09 April 2019 (09.04.2019)	US
16/459,388	01 July 2019 (01.07.2019)	US

(71) Applicant: **SIGMA PHASE, CORP.** [US/US]; 49 Waltham Street, Suite 1, Lexington, Massachusetts 02421 (US).

(72) Inventors: **FONTE, Matthew**; 49 Waltham Street, Suite 1, Lexington, Massachusetts 02421 (US). **HEYMANS, John**; 49 Waltham Street, Suite 1, Lexington, Massachusetts 02421 (US). **FICHERA, Benjamin**; 49 Waltham Street, Suite 1, Lexington, Massachusetts 02421 (US). **HUGENROTH, Jason**; 49 Waltham Street, Suite 1, Lexington, Massachusetts 02421 (US).

(74) Agent: **DEAN, Sean M.**; Fish & Richardson P.C., P. O. Box 1022, Minneapolis, Minnesota 55440-1022 (US).

(81) Designated States (unless otherwise indicated, for every kind of national protection available): AE, AG, AL, AM, AO, AT, AU, AZ, BA, BB, BG, BH, BN, BR, BW, BY, BZ, CA, CH, CL, CN, CO, CR, CU, CZ, DE, DJ, DK, DM, DO, DZ, EC, EE, EG, ES, FI, GB, GD, GE, GH, GM, GT, HN, HR, HU, ID, IL, IN, IR, IS, JO, JP, KE, KG, KH, KN, KP, KR, KW, KZ, LA, LC, LK, LR, LS, LU, LY, MA, MD, ME, MG, MK, MN, MW, MX, MY, MZ, NA, NG, NI, NO, NZ, OM, PA, PE, PG, PH, PL, PT, QA, RO, RS, RU, RW, SA, SC, SD, SE, SG, SK, SL, SM, ST, SV, SY, TH, TJ, TM, TN, TR, TT, TZ, UA, UG, US, UZ, VC, VN, ZA, ZM, ZW.

(84) Designated States (unless otherwise indicated, for every kind of regional protection available): ARIPO (BW, GH, GM, KE, LR, LS, MW, MZ, NA, RW, SD, SL, ST, SZ, TZ, UG, ZM, ZW), Eurasian (AM, AZ, BY, KG, KZ, RU, TJ, TM), European (AL, AT, BE, BG, CH, CY, CZ, DE, DK,

(54) Title: PROVIDING SINGLE SERVINGS OF COOLED FOODS AND DRINKS

(57) Abstract: Systems and methods have demonstrated the capability of rapidly cooling the contents of pods containing the ingredients for food and drinks.

WO 2020/037296 A1

Providing Single Servings of Cooled Foods and Drinks

RELATED APPLICATIONS

[0001] This patent application is a continuation-in-part of patent application U.S. Ser. No. 16/104,758, filed on August 17, 2018 and claims the benefit of provisional patent applications U.S. Ser. No. 62/758,110, filed on November 9, 2018; U.S. Ser. No. 62/801,587, filed on February 5, 2019; U.S. Ser. No. 62/831,657, filed on April 9, 2019; U.S. Ser. No. 62/831,600, filed on April 9, 2019; U.S. Ser. No. 62/831,646, filed on April 9, 2019; and U.S. Ser. No. 62/831,666, filed on April 9, 2019, all of which are hereby incorporated herein by reference in their entirety.

TECHNICAL FIELD

[0002] This disclosure relates to systems and methods for rapidly cooling food and drinks.

BACKGROUND

[0003] Beverage brewing systems have been developed that rapidly prepare single servings of hot beverages. Some of these brewing systems rely on single use pods to which water is added before brewing occurs. The pods can be used to prepare hot coffees, teas, cocoas, and dairy-based beverages.

[0004] Home use ice cream makers can be used to make larger batches (e.g., 1.5 quarts or more) of ice cream for personal consumption. These ice cream maker appliances typically prepare the mixture by employing a hand-crank method or by employing an electric motor that is used, in turn, to assist in churning the ingredients within the appliance. The resulting preparation is often chilled using a pre-cooled vessel that is inserted into the machine.

SUMMARY

[0005] This specification describes systems and methods for rapidly cooling food and drinks. Some of these systems and methods can cool food and drinks in a container

inserted into a counter-top or installed machine from room temperature to freezing in less than two minutes. For example, the approach described in this specification has successfully demonstrated the ability make soft-serve ice cream from room-temperature pods in approximately 90 seconds. This approach has also been used to chill cocktails and other drinks including to produce frozen drinks. These systems and methods are based on a refrigeration cycle with low startup times and a pod-machine interface that is easy to use and provides extremely efficient heat transfer. Some of the pods described are filled with ingredients in a manufacturing line and subjected to a sterilization process (e.g., retort, aseptic packaging, ultra-high temperature processing (UHT), ultra-heat treatment, ultra-pasteurization, or high pressure processing (HPP)). HPP is a cold pasteurization technique by which products, already sealed in its final package, are introduced into a vessel and subjected to a high level of isostatic pressure (300–600 megapascals (MPa) (43,500 – 87,000 pounds per square inch (psi)) transmitted by water. The pods can be used to store ingredients including, for example, dairy products at room temperature for long periods of time (e.g., 9-12 months) following sterilization.

[0006] Cooling is used to indicate the transfer of thermal energy to reduce the temperature, for example, of ingredients contained in a pod. In some cases, cooling indicates the transfer of thermal energy to reduce the temperature, for example, of ingredients contained in a pod to below freezing.

[0007] Some machines for producing cooled food or drinks from ingredients in a pod containing the ingredients include: an evaporator of a refrigeration system, the evaporator defining a receptacle sized to receive the pod; and wherein the refrigeration system has a working fluid loop that runs from the evaporator to a compressor to a condenser to an expansion valve or capillary tube back to the evaporator and also includes a first bypass line that extends from the working fluid loop between the compressor and the condenser to the working fluid loop between the expansion valve and the evaporator.

[0008] Some machines for reducing the temperature of ingredients in a pod containing the ingredients and at least one mixing paddle include: an evaporator of a refrigeration system, the evaporator defining a receptacle sized to receive the pod; a

motor operable to move the at least one internal mixing paddle of a pod in the receptacle; wherein the refrigeration system has a working fluid loop that runs from the evaporator to a compressor to a condenser to an expansion valve back to the evaporator and also includes a first bypass line that extends from the working fluid loop between the
60 compressor and the condenser to the working fluid loop between the expansion valve and the evaporator and a bypass valve on the first bypass line.

[0009] Some machines for producing cooling ingredients in a pod containing the ingredients and at least one internal mixing paddle include: an evaporator of a refrigeration system, the evaporator defining a receptacle sized to receive the single use
65 pod; and a motor operable to move the at least one internal mixing paddle of a pod in the receptacle; wherein the refrigeration system has a working fluid loop that runs from the evaporator to a compressor to a condenser to an expansion valve back to the evaporator and also includes a first bypass line that extends from the working fluid loop between the compressor and the condenser to the working fluid loop between the expansion valve and
70 the evaporator and a bypass valve on the first bypass line.

[0010] Some machines for producing cooling ingredients in a pod containing the ingredients and at least one internal mixing paddle include: an evaporator of a refrigeration system, the evaporator defining a receptacle sized to receive the pod; and a motor operable to move the internal mixing paddle of a pod in the receptacle; wherein the
75 refrigeration system has a working fluid loop that runs from the evaporator to a compressor to a condenser to an expansion valve back to the evaporator and also includes a first bypass line that extends from the working fluid loop between the compressor and the condenser to the working fluid loop between the evaporator and the compressor.

[0011] Some machines for producing cooling ingredients in a pod containing the ingredients and at least one internal mixing paddle include: an evaporator of a refrigeration system, the evaporator defining a receptacle sized to receive the pod; and a motor operable to move the internal mixing paddle of a pod in the receptacle; wherein the refrigeration system has a working fluid loop that runs from the evaporator to a compressor to a condenser to a pressure vessel to an expansion valve back to the
80 evaporator and the working fluid loop includes a first isolation valve between the
85 evaporator and the working fluid loop includes a first isolation valve between the

pressure vessel and the expansion valve and a second isolation valve between the compressor and the condenser.

[0012] Some machines for producing cooling ingredients in a pod containing the ingredients and at least one internal mixing paddle include: an evaporator of a
90 refrigeration system, the evaporator defining a receptacle sized to receive the pod; and a motor operable to move the internal mixing paddle of a pod in the receptacle; wherein the refrigeration system has a working fluid loop that runs from the evaporator to a compressor to a condenser to an expansion valve back to the evaporator and the working fluid loop passes through a thermoelectric cooler between the condenser and the
95 expansion valve.

[0013] Some machines for producing cooled food or drinks from ingredients in a pod containing the ingredients include: an evaporator of a refrigeration system, the evaporator defining a receptacle sized to receive the pod; and wherein the refrigeration system has a working fluid loop that runs from the evaporator to a compressor to a
100 condenser to an expansion valve or capillary tube back to the evaporator; and wherein the evaporator is made of a material that has at least 160 W/mk thermal conductivity.

[0014] Some machines for producing cooled food or drinks from ingredients in a pod containing the ingredients include: an evaporator of a refrigeration system, the evaporator defining a receptacle sized to receive the pod; wherein the refrigeration
105 system has a working fluid loop that runs from the evaporator to a compressor to a condenser to an expansion valve or capillary tube back to the evaporator; and wherein a refrigerant is selected from the group consisting of R143A, R134a, R410a, R32 and R404a, carbon dioxide, ammonia, propane and isobutane.

[0015] Some machines for producing cooled food or drinks from ingredients in a
110 pod containing the ingredients include: an evaporator of a refrigeration system, the evaporator defining a receptacle sized to receive the pod; wherein the refrigeration system has a working fluid loop that runs from the evaporator to a compressor to a condenser to an expansion sub-system, comprising multiple orifices or expansion devices in parallel, back to the evaporator.

115 [0016] Some machines for producing cooled food or drinks from ingredients in a
pod containing the ingredients include: an evaporator of a refrigeration system, the
evaporator defining a receptacle sized to receive the pod; wherein the refrigeration
system has a working fluid loop that runs from the evaporator to a compressor to a
condenser to an expansion valve or capillary tube to a refrigerant line that pre-chills a
120 tank of water, back to the evaporator.

[0017] Some machines for producing cooled food or drinks from ingredients in a
pod containing the ingredients include: an evaporator of a refrigeration system, the
evaporator defining a receptacle sized to receive the pod; wherein the refrigeration
system has a working fluid loop that runs from the evaporator to the one side of a thermal
125 battery to a compressor to a condenser to the other side of a thermal battery to an
expansion valve or capillary tube, back to the evaporator.

[0018] Embodiments of these machines can include one or more of the following
features.

[0019] In some embodiments, machines also include a bypass valve on the first
130 bypass line.

[0020] In some embodiments, machines also include a second bypass line that
extends from the working fluid loop between the compressor and the condenser to the
working fluid loop between the evaporator and the compressor. In some cases, machines
also include a bypass valve on the second bypass line. In some cases, machines also
135 include a suction line heat exchanger.

[0021] In some embodiments, the working fluid loop passes through a reservoir of
phase change material disposed between the compressor and the condenser. In some
cases, the phase change material comprises ethylene glycol and water mixture, salt water,
paraffin wax, alkanes, or pure water or a combination thereof. In some cases, the working
140 fluid loop includes a pressure vessel between the condenser and the evaporator, a first
isolation valve between the pressure vessel and the expansion valve, and a second
isolation valve between the compressor and the condenser. In some cases, the working
fluid loop passes through a thermoelectric cooler between the condenser and the
expansion valve.

[0022] In some embodiments, machines also include an aluminum evaporator with a mass of not exceeding 1.50 pounds.

[0023] In some embodiments, machines also include a pressure drop through the refrigeration system less than 2 psi.

5 [0024] In some embodiments, machines also include a pod to evaporator heat transfer surface of up to 50 square inches.

[0025] In some embodiments, machines also include an evaporator has cooling channels in it allowing for the fluid mass velocity up to 180,000 lb/ (hour feet squared). has refrigerant wetted surface area of up to 200 square inches.

10 [0026] In some embodiments, machines also include an evaporator refrigerant wetted surface area of up to 200 square inches.

[0027] In some embodiments, machines also include an evaporator that clamps down on the pod.

15 [0028] In some embodiments, machines also include an evaporator that has an internal wall of copper adjacent to the pod.

[0029] In some embodiments, machines also include an evaporator that is constructed of microchannels.

[0030] The systems and methods described in this specification can provide a number of advantages. Some embodiments of these systems and methods can provide
20 single servings of cooled food or drink. This approach can help consumers with portion control. Some embodiments of these systems and methods can provide consumers the ability to choose their single-serving flavors, for example, of soft serve ice cream. Some embodiments of these systems and methods incorporate shelf-stable pods that do not require pre-cooling, pre-freezing or other preparation. Some embodiments of these
25 systems and methods can generate frozen food or drinks from room-temperature pods in less than two minutes (in some cases, less than one minute). Some embodiments of these systems and methods do not require post-processing clean up once the cooled or frozen food or drink is generated. Some embodiments of these systems and methods utilize aluminum pods that are recyclable.

[0031] The details of one or more embodiments of these systems and methods are set forth in the accompanying drawings and the description below. Other features, objects, and advantages of these systems and methods will be apparent from the description and drawings, and from the claims.

5

DESCRIPTION OF DRAWINGS

[0032] Figure 1A is a perspective view of a machine for rapidly cooling food and drinks. Figure 1B shows the machine without its housing.

[0033] Figure 1C is a perspective view of a portion of the machine of Figure 1A.

[0034] Figure 2A is perspective view of the machine of Figure 1A with the cover of the pod-machine interface illustrated as being transparent to allow a more detailed view of the evaporator to be seen.

[0035] Figure 2B is a top view of a portion of the machine without the housing and the pod-machine interface without the lid.

[0036] Figures 2C and 2D are, respectively, a perspective view and a side view of the evaporator.

[0037] Figures 3A – 3F show components of a pod-machine interface that are operable to open and close pods in the evaporator to dispense the food or drink being produced.

[0038] Figure 4 is a schematic of a refrigeration system.

[0039] Figures 5A and 5B are views of a prototype of a condenser.

[0040] Figure 6A is a side view of a pod.

[0041] Figure 6B is a schematic side view of the pod and a mixing paddle disposed in the pod.

[0042] Figures 7A and 7B are perspective views of a pod and an associated driveshaft.

[0043] Figure 7C is a cross-section of a portion of the pod with the driveshaft engaged with a mixing paddle in the pod.

[0044] Figure 8 shows a first end of a pod with its cap spaced apart from its base for ease of viewing.

[0045] Figures 9A – 9G illustrate rotation of a cap around the first end of the pod to open an aperture extending through the base.

[0046] Figure 10 is an enlarged schematic side view of a pod.

5 [0047] Figure 11 is a flow chart of a method for operating a machine for producing cooled food or drinks.

[0048] Figure 12 is a schematic of a refrigeration system that includes an evaporator and an expansion sub-system.

[0049] Figure 13 is a schematic of a refrigeration system that includes a bypass line that pre-chills a tank of water prior upstream of an evaporator.

10 [0050] Figure 14 is a schematic of a refrigeration system that includes a thermal mass disposed between a compressor and a condenser.

[0051] Figure 15 is a schematic of a refrigeration system that includes a pressure vessel, a first control valve, and a second control valve.

15 [0052] Figure 16 is a schematic of a refrigeration system that includes a thermoelectric module.

[0053] Figure 17 is a schematic of a refrigeration system that includes a thermal battery, a first battery bypass valve, and a second battery bypass valve.

[0054] Figure 18A is top view of an evaporator cover 127 and Figure 18B is a top view of the body of the evaporator.

20 [0055] Figures 19A and 19B are perspective views of an evaporator with and without an associated lid.

[0056] Figures 20A-20D are schematics of flow paths formed by the channels of the evaporator and an associated lid.

25 [0057] Figures 21A-21C are views of the pod and the evaporator of with a closing mechanism.

[0058] Figures 22A and 22B are side views of a closing mechanism that includes a first bolt and a second bolt.

[0059] Figures 23A – 23H illustrate an evaporator with an extruded body.

[0060] Figure 24 illustrates an evaporator incorporating an orifice plate.

[0061] Figure 25 is a perspective view of an evaporator, shown in Figures 19A and 19B with an internal surface made of a different material than the evaporator.

[0062] Figures 26A-26C are schematic views of claddings.

[0063] Figure 27 is an exemplary view of a material that includes microchannels.

5 [0064] Figures 28A-28C are top views of a rotary compressor.

[0065] Like reference symbols in the various drawings indicate like elements.

DETAILED DESCRIPTION

[0066] This specification describes systems and methods for rapidly cooling food and drinks. Some of these systems and methods use a counter-top or installed machine to
10 cool food and drinks in a container from room temperature to freezing in less than two minutes. For example, the approach described in this specification has successfully demonstrated the ability make soft-serve ice cream, frozen coffees, frozen smoothies, and frozen cocktails, from room temperature pods in approximately 90 seconds. This approach can also be used to chill cocktails, create frozen smoothies, frozen protein and
15 other functional beverage shakes (e.g., collagen-based, energy, plant-based, non-dairy, CBD shakes), frozen coffee drinks and chilled coffee drinks with and without nitrogen in them, create hard ice cream, create milk shakes, create frozen yogurt and chilled probiotic drinks. These systems and methods are based on a refrigeration cycle with low startup times and a pod-machine interface that is easy to use and provides extremely efficient
20 heat transfer. Some of the pods described can be sterilized (e.g., using retort sterilization) and used to store ingredients including, for example, dairy products at room temperature for up to 18 months.

[0067] Figure 1A is a perspective view of a machine 100 for cooling food or drinks. Figure 1B shows the machine without its housing. The machine 100 reduces the
25 temperature of ingredients in a pod containing the ingredients. Most pods include a mixing paddle used to mix the ingredients before dispensing the cooled or frozen products. The machine 100 includes a body 102 that includes a compressor, a condenser, a fan, an evaporator, capillary tubes, a control system, a lid system and a dispensing system with a housing 104 and a pod-machine interface 106. The pod-machine interface

106 includes an evaporator 108 of a refrigeration system 109 whose other components are disposed inside the housing 104. As shown on Figure 1B, the evaporator 108 defines a receptacle 110 sized to receive a pod.

[0068] A lid 112 is attached to the housing 104 via a hinge 114. The lid 112 can rotate between a closed position covering the receptacle 110 (Figure 1A) and an open position exposing the receptacle 110 (Figure 1B). In the closed position, the lid 112 covers the receptacle 110 and is locked in place. In the machine 100, a latch 116 on the lid 112 engages with a latch recess 118 on the pod-machine interface 106. A latch sensor 120 is disposed in the latch recess 118 to determine if the latch 116 is engaged with the latch recess 118. A processor 122 is electronically connected to the latch sensor 120 and recognizes that the lid 112 is closed when the latch sensor 120 determines that the latch 116 and the latch recess 118 are engaged.

[0069] An auxiliary cover 115 rotates upward as the lid 112 is moved from its closed position to its open position. Some auxiliary covers slide into the housing when the lid moves into the open position.

[0070] In the machine 100, the evaporator 108 is fixed in position with respect to the body 102 of the machine 100 and access to the receptacle 110 is provided by movement of the lid 112. In some machines, the evaporator 108 is displaceable relative to the body 102 and movement of the evaporator 108 provides access to the receptacle 110.

[0071] A motor 124 disposed in the housing 104 is mechanically connected to a driveshaft 126 that extends from the lid 112. When the lid 112 is in its closed position, the driveshaft 126 extends into the receptacle 110 and, if a pod is present, engages with the pod to move a paddle or paddles within the pod. The processor 122 is in electronic communication with the motor 124 and controls operation of the motor 124. In some machines, the shaft associated with the paddle(s) of the pod extends outward from the pod and the lid 112 has a rotating receptacle (instead of the driveshaft 126) mechanically connected to the motor 124.

[0072] Figure 1C is perspective view of the lid 112 shown separately so the belt 125 that extends from motor 124 to the driveshaft 126 is visible. Referring again to Figure 1B, the motor 124 is mounted on a plate that runs along rails 127. The plate can

move approximately 0.25 inches to adjust the tension on the belt. During assembly, the plate slides along the rails. Springs disposed between the plate and the lid 112 bias the lid 112 away from the plate to maintain tension in the belt.

[0073] Figure 2A is a perspective view of the machine 100 with the cover of the pod-machine interface 106 illustrated as being transparent to allow a more detailed view of the evaporator 108 to be seen. Figure 2B is a top view of a portion of the machine 100 without housing 104 and the pod-machine interface 106 without the lid 112. Figures 2C and 2D are, respectively, a perspective view and a side view of the evaporator 108. Other pod-machine interfaces are described in more detail in U.S. Pat. App. Ser. No. _____ (attorney docket number 47354-0009001) filed contemporaneously with this application and incorporated herein by reference in its entirety.

[0074] The evaporator 108 has a clamshell configuration with a first portion 128 attached to a second portion 130 by a living hinge 132 on one side and separated by a gap 134 on the other side. Refrigerant flows to the evaporator 108 from other components of the refrigeration system through fluid channels 136 (best seen on Figure 2B). The refrigerant flows through the evaporator 108 in internal channels through the first portion 128, the living hinge 132, and the second portion 130.

[0075] The space 137 (best seen on Figure 2B) between the outer wall of the evaporator 108 and the inner wall of the casing of the pod-machine interface 106 is filled with an insulating material to reduce heat exchange between the environment and the evaporator 108. In the machine 100, the space 137 is filled with an aerogel (not shown). Some machines use other insulating material, for example, an annulus (such as an airspace), insulating foams made of various polymers, or fiberglass wool.

[0076] The evaporator 108 has an open position and a closed position. In the open position, the gap 134 opens to provide an air gap between the first portion 128 and the second portion 130. In the machine 100, the first portion 128 and the second portion 130 are pressed together in the closed position. In some machines, the first and second portion are pressed towards each other and the gap is reduced, but still defined by a space between the first and second portions in the closed position.

[0077] The inner diameter ID of the evaporator 108 is slightly larger in the open position than in the closed position. Pods can be inserted into and removed from the evaporator 108 while the evaporator is in the open position. Transitioning the evaporator 108 from its open position to its closed position after a pod is inserted tightens the evaporator 108 around the outer diameter of the pod. For example, the machine 100 is configured to use pods with 2.085" outer diameter. The evaporator 108 has an inner diameter of 2.115" in the open position and an inner diameter inner diameter of 2.085" in the closed position. Some machines have evaporators sized and configured to cool other pods. The pods can be formed from commercially available can sizes, for example, "slim" cans with diameters ranging from 2.080 inches – 2.090 inches and volumes of 180 milliliters (ml) – 300 ml, "sleek" cans with diameters ranging from 2.250 inches – 2.400 inches and volumes of 180 ml – 400 ml and "standard" size cans with diameters ranging from 2.500 inches – 2.600 inches and volumes of 200 ml – 500 ml. The machine 100 is configured to use pods with 2.085 inches outer diameter. The evaporator 108 has an inner diameter of 2.115 inches in its open position and an inner diameter inner diameter of 2.085 inches in its closed position. Some machines have evaporators sized and configured to cool other pods.

[0078] The closed position of evaporator 108 improves heat transfer between inserted pod 150 and the evaporator 108 by increasing the contact area between the pod 150 and the evaporator 108 and reducing or eliminating an air gap between the wall of the pod 150 and the evaporator 108. In some pods, the pressure applied to the pod by the evaporator 108 is opposed by the mixing paddles, pressurized gases within the pod, or both to maintain the casing shape of the pod.

[0079] In the evaporator 108, the relative position of the first portion 128 and the second portion 130 and the size of the gap 134 between them is controlled by two bars 138 connected by a bolt 140 and two springs 142. Each of the bars 138 has a threaded central hole through which the bolt 140 extends and two end holes engaging the pins 144. Each of the two springs 142 is disposed around a pin 144 that extends between the bars 138. Some machines use other systems to control the size of the gap 134, for example, circumferential cable systems with cables that extend around the outer diameter of the

evaporator 108 with the cable being tightened to close the evaporator 108 and loosened to open the evaporator 108. In other evaporators, there are a plurality of bolts and end holes, one or more than two springs, and one or more than engaging pins.

[0080] One bar 138 is mounted on the first portion 128 of the evaporator 108 and
5 the other bar 138 is mounted on the second portion 130 of the evaporator 108. In some evaporators, the bars 138 are integral to the body of the evaporator 108 rather than being mounted on the body of the evaporator. The springs 142 press the bars 138 away from each other. The spring force biases the first portion 128 and the second portion 130 of the evaporator 108 away from each at the gap 134. Rotation of the bolt 140 in one direction
10 increases a force pushing the bars 138 towards each and rotation of the bolt in the opposite direction decreases this force. When the force applied by the bolt 140 is greater than the spring force, the bars 138 bring the first portion 128 and the second portion 130 of the evaporator together.

[0081] The machine 100 includes an electric motor 146 (shown on Figure 2B)
15 that is operable to rotate the bolt 140 to control the size of the gap 134. Some machines use other mechanisms to rotate the bolt 140. For example, some machines use a mechanical linkage, for example, between the lid 112 and the bolt 140 to rotate the bolt 140 as the lid 112 is opened and closed. Some machines include a handle that can be attached to the bolt to manually tighten or loosen the bolt. Some machines have a wedge
20 system that forces the bars into a closed position when the machine lid is shut. This approach may be used instead of the electric motor 146 or can be provided as a backup in case the motor fails.

[0082] The electric motor 146 is in communication with and controlled by the processor 122 of the machine 100. Some electric drives include a torque sensor that sends
25 torque measurements to the processor 122. The processor 122 signals to the motor to rotate the bolt 140 in a first direction to press the bars 138 together, for example, when a pod sensor indicates that a pod is disposed in the receptacle 110 or when the latch sensor 120 indicates that the lid 112 and pod-machine interface 106 are engaged. It is desirable that the clamshell evaporator be shut and holding the pod in a tightly fixed position
30 before the lid closes and the shaft pierces the pod and engages the mixing paddle. This

positioning can be important for driveshaft-mixing paddle engagement. The processor 122 signals to the electric drive to rotate the bolt 140 in the second direction, for example, after the food or drink being produced has been cooled/frozen and dispensed from the machine 100, thereby opening the evaporator gap 134 and allowing for easy removal of pod 150 from evaporator 108.

[0083] The base of the evaporator 108 has three bores 148 (see Figure 2C) which are used to mount the evaporator 108 to the floor of the pod-machine interface 106. All three of the bores 148 extend through the base of the second portion 130 of the evaporator 108. The first portion 128 of the evaporator 108 is not directly attached to the floor of the pod-machine interface 106. This configuration enables the opening and closing movement described above. Other configurations that enable the opening and closing movement of the evaporator 108 can also be used. Some machines have more or fewer than three bores 148. Some evaporators are mounted to components other than the floor of the pod-machine interface, for example, the dispensing mechanism.

[0084] Many factors affect the performance of a refrigeration system. Important factors include mass velocity of refrigerant flowing through the system, the refrigerant wetted surface area, the refrigeration process, the area of the pod/evaporator heat transfer surface, the mass of the evaporator, and the thermal conductivity of the material of the heat transfer surface. Extensive modeling and empirical studies in the development of the prototype systems described in this specification have determined that appropriate choices for the mass velocity of refrigerant flowing through the system and the refrigerant wetted surface area are the most important parameters to balance to provide a system capable of freezing up to 12 ounces of confection in less than 2 minutes.

[0085] The evaporators described in this specification can have the following characteristics:

Mass Velocity	60,000 to 180,000 lb / (hour feet squared)
Refrigerant Wetted Surface Area	35 to 200 square inches
Pressure drop Through Refrigeration Process	less than 2 psi pressure drop across the evaporator
Pod/Evaporator Heat Transfer Surface	15 to 50 square inches
Mass of Evaporator	0.100 to 1.50 pounds

Minimum Conductivity of the Material	160 W/mK
--------------------------------------	----------

The following paragraphs describe the significance of these parameters in more detail.

[0086] Mass velocity accounts for the multi-phase nature of refrigerant flowing through an evaporator. The two-phase process takes advantage of the high amounts of heat absorbed and expended when a refrigerant fluid (e.g., R-290 propane) changes state from a liquid to gas and a gas to a liquid, respectively. The rate of heat transfer depends in part on exposing the evaporator inner surfaces with a new liquid refrigerant to vaporize and cool the liquid ice cream mix. To do this the velocity of the refrigerant fluid must be high enough for vapor to channel or flow down the center of the flow path within the walls of evaporator and for liquid refrigerant to be pushed thru these channel passages within the walls. One approximate measurement of fluid velocity in a refrigeration system is mass velocity - the mass flow of refrigerant in a system per unit cross sectional area of the flow passage in units of lb/hr ft². Velocity as measured in ft/s (a more familiar way to measure “velocity”) is difficult to apply in a two-phase system since the velocity (ft/s) is constantly changing as the fluid flow changes state from liquid to gas. If liquid refrigerant is constantly sweeping across the evaporator walls, it can be vaporized and new liquid can be pushed against the wall of the cooling channels by the “core” of vapor flowing down the middle of the passage. At low velocities, flow separates based on gravity and liquid remains on the bottom of the cooling passage within the evaporator and vapor rises to the top side of the cooling passage channels. If the amount of area exposed to liquid is reduced by half, for example, this could cut the amount of heat transfer almost half. According to the American Society of Heating, Refrigerating and Air-Conditioning Engineers (ASHRAE), a mass velocity of 150,000 lb/hr ft² maximizes performance for the majority of the evaporator flow path. Mass velocity is one of the parameters that must be balanced to optimize a refrigerant system. The parameters that affect the performance of the evaporator are mass flow rate, convective heat transfer coefficient, and pressure drop. The nominal operating pressure of the evaporator is determined by the required temperature of the evaporator and the properties of the refrigerant used in the system. The mass flow rate of refrigerant through the evaporator must be high enough for it to absorb the amount of thermal energy from the confection to

freeze it, in a given amount of time. Mass flow rate is primarily determined by the size of the compressor. It is desirable to use the smallest possible compressor to reduce, cost, weight and size. The convective heat transfer coefficient is influenced by the mass velocity and wetted surface area of the evaporator. The convective heat transfer

5 coefficient will increase with increased mass velocity. However, pressure drop will also increase with mass velocity. This in turn increases the power required to operate the compressor and reduces the mass flow rate the compressor can deliver. It is desirable to design the evaporator to meet performance objectives while using the smallest least expensive compressor possible. We have determined that evaporators with a mass

10 velocity of 75,000 – 125,000 lb/hr ft² are effective in helping provide a system capable of freezing up to 12 ounces of confection in less than 2 minutes. The latest prototype has a mass velocity of approximately 100,000 lb/hr ft² and provides a good balance of high mass velocity, manageable pressure drop in the system, and a reasonable sized compressor.

15 [0087] Another important factor that affects performance in an evaporator is the surface area wetted by refrigerant which is the area of all the cooling channels within the evaporator exposed to refrigerant. Increasing the wetted surface area can improve heat transfer characteristics of an evaporator. However, increasing the wetted surface area can increase the mass of the evaporator which would increase thermal inertia and degrade

20 heat transfer characteristics of the evaporator.

[0088] The amount of heat that can be transferred out of the liquid in a pod is proportional to the surface area of the pod / evaporator heat transfer surface. A larger surface area is desirable but increases in surface area can require increasing the mass of the evaporator which would degrade heat transfer characteristics of the evaporator. We

25 have determined that evaporators in which the area of the pod/evaporator heat transfer surface is between 20 and 40 square inches are effectively combined with the other characteristics to help provide a system capable of freezing up to 12 ounces of confection in less than 2 minutes.

[0089] Thermal conductivity is the intrinsic property of a material which relates

30 its ability to conduct heat. Heat transfer by conduction involves transfer of energy within

a material without any motion of the material as a whole. An evaporator with walls made of a high conductivity material (e.g., aluminum) reduces the temperature difference across the evaporator walls. Reducing this temperature difference reduces the work required for the refrigeration system to cool the evaporator to the right temperature.

5 [0090] For the desired heat transfer to occur, the evaporator must be cooled. The greater the mass of the evaporator, the longer this cooling will take. Reducing evaporator mass reduces the amount of material that must be cooled during a freezing cycle. An evaporator with a large mass will increase the time require to freeze up to 12 ounces of confection.

10 [0091] The effects of thermal conductivity and mass can be balanced by an appropriate choice of materials. There are materials with higher thermal conductivity than aluminum such as copper. However, the density of copper is greater that the density of aluminum. For this reason, some evaporators have been constructed that use high thermal conductive copper only on the heat exchange surfaces of the evaporator and use
15 aluminum everywhere else.

[0092] Figures 3A – 3F show components of the pod-machine interface 106 that are operable to open pods in the evaporator 108 to dispense the food or drink being produced by the machine 100. This is an example of one approach to opening pods but some machines and the associated pods use other approaches.

20 [0093] Figure 3A is a partially cutaway schematic view of the pod-machine interface 106 with a pod 150 placed in the evaporator 108. Figure 3B is a schematic plan view looking upwards that shows the relationship between the end of the pod 150 and the floor 152 of the pod-machine interface 106. The floor 152 of the pod-machine interface 106 is formed by a dispenser 153. Figures 3C and 3D are perspective views of a
25 dispenser 153. Figures 3E and 3F are perspective views of an insert 154 that is disposed in the dispenser 153. The insert 154 includes an electric motor 146 operable to drive a worm gear 157 floor 152 of the pod-machine interface 106. The worm gear 157 is engaged with a gear 159 with an annular configuration. An annular member 161 mounted on the gear 159 extends from the gear 159 into an interior region of the pod-machine
30 interface 106. The annular member 161 has protrusions 163 that are configured to engage

with a pod inserted into the pod-machine interface 106 to open the pod. The protrusions 163 of the annular member 161 are four dowel-shaped protrusions. Some annular gears have more protrusions or fewer protrusions and the protrusions can have other shapes, for example, “teeth.”

5 [0094] The pod 150 includes a body 158 containing a mixing paddle 160 (see Figure 3A). The pod 150 also has a base 162 defining an aperture 164 and a cap 166 extending across the base 162 (see Figure 3B). The base 162 is seamed/fixed onto the body 158 of the pod 150. The base 162 includes a protrusion 165. The cap 166 mounted over base 162 is rotatable around the circumference/axis of the pod 150. In use, when the product is ready to be dispensed from the pod 150, the dispenser 153 of the machine
10 engages and rotates the cap 166 around the first end of the pod 150. Cap 166 is rotated to a position to engage and then separate the protrusion 165 from the rest of the base 162. The pod 150 and its components are described in more detail with respect to Figures 6A – 10.

15 [0095] The aperture 164 in the base 162 is opened by rotation of the cap 166. The pod-machine interface 106 includes an electric motor 146 with threading that engages the outer circumference of a gear 168. Operation of the electric motor 146 causes the gear 168 to rotate. The gear 168 is attached to a annular member 161 and rotation of the gear 168 rotates the annular member 161. The gear 168 and the annular member 161 are both
20 annular and together define a central bore through which food or drink can be dispensed from the pod 150 through the aperture 164 without contacting the gear 168 or the annular member 161. When the pod 150 is placed in the evaporator 108, the annular member 161 engages the cap 166 and rotation of the annular member 161 rotates the cap 166.

[0096] Figure 4 is a schematic of the refrigeration system 109 that includes the
25 evaporator 108. The refrigeration system also includes a condenser 180, a suction line heat exchanger 182, an expansion valve 184, and a compressor 186. High-pressure, liquid refrigerant flows from the condenser 180 through the suction line heat exchanger 182 and the expansion valve 184 to the evaporator 108. The expansion valve 184 restricts the flow of the liquid refrigerant fluid and lowers the pressure of the liquid refrigerant as it leaves
30 the expansion valve 184. The low-pressure liquid-vapor mixture then moves to the

evaporator 108 where heat absorbed from a pod 150 and its contents in the evaporator 108 changes the refrigerant from a liquid-vapor mixture to a gas. The gas-phase refrigerant flows from the evaporator 108 to the compressor 186 through the suction line heat exchanger 182. In the suction line heat exchanger 182, the cold vapor leaving the evaporator 108 pre-cools the liquid leaving the condenser 180. The refrigerant enters the compressor 186 as a low-pressure gas and leaves the compressor 186 as a high-pressure gas. The gas then flows to the condenser 180 where heat exchange cools and condenses the refrigerant to a liquid.

[0097] The refrigeration system 109 includes a first bypass line 188 and second bypass line 190. The first bypass line 188 directly connects the discharge of the compressor 186 to the inlet of the compressor 186. Disposed on the both the first bypass line and second bypass line are bypass valves that open and close the passage to allow refrigerant bypass flow. Diverting the refrigerant directly from the compressor discharge to the inlet can provide evaporator defrosting and temperature control without injecting hot gas to the evaporator. The first bypass line 188 also provides a means for rapid pressure equalization across the compressor 186, which allows for rapid restarting (i.e., freezing one pod after another quickly). The second bypass line 190 enables the application of warm gas to the evaporator 108 to defrost the evaporator 108. The bypass valves may be, for example, solenoid valves or throttle valves.

[0098] Figures 5A and 5B are views of a prototype of the condenser 180. The condenser has internal channels 192. The internal channels 192 increase the surface area that interacts with the refrigerant cooling the refrigerant quickly. These images show micro-channel tubing which are used because they have small channels which keeps the coolant velocity up and are thin wall for good heat transfer and have little mass to prevent the condenser for being a heat sink.

[0099] Figures 6A and 6B show an example of a pod 150 for use with the machine 100 described with respect to Figures 1A – 3F. Figure 6A is a side view of the pod 150. Figure 6B is a schematic side view of the pod 150 and the mixing paddle 160 disposed in the body 158 of the pod 150. Other pod-machine interfaces that can be used with this and similar machines are described in more detail in U.S. Pat. App. Ser. No.

_____ (attorney docket number 47354-0010001) filed contemporaneously with this application and incorporated herein by reference in its entirety.

[0100] The pod 150 is sized to fit in the receptacle 110 of the machine 100. The pods can be sized to provide a single serving of the food or drink being produced.

5 Typically, pods have a volume between 6 and 18 fluid ounces. The pod 150 has a volume of approximately 8.5 fluid ounces.

[0101] The body 158 of the pod 150 is a can that contains the mixing paddle 160. The body 158 extends from a first end 210 at the base to a second end 212 and has a circular cross-section. The first end 210 has a diameter D_{UE} that is slightly larger than the diameter D_{LE} of the second end 212. This configuration facilitates stacking multiple pods 200 on top of one another with the first end 210 of one pod receiving the second end 212 of another pod.

[0102] A wall 214 connects the first end 210 to the second end 212. The wall 214 has a first neck 216, second neck 218, and a barrel 220 between the first neck 216 and the second neck 218. The barrel 220 has a circular cross-section with a diameter D_B . The diameter D_B is larger than both the diameter D_{UE} of the first end 210 and the diameter D_{LE} of the second end 212. The first neck 216 connects the barrel 220 to the first end 210 and slopes as the first neck 216 extends from the smaller diameter D_{UE} to the larger diameter D_B the barrel 220. The second neck 218 connects the barrel 220 to the second end 212 and slopes as the second neck 218 extends from the larger diameter D_B of the barrel 220 to the smaller diameter D_{LE} of the second end 212. The second neck 218 is sloped more steeply than the first neck 216 as the second end 212 has a smaller diameter than the first end 210.

[0103] This configuration of the pod 150 provides increased material usage; i.e., the ability to use more base material (e.g., aluminum) per pod. This configuration further assists with the columnar strength of the pod.

[0104] The pod 150 is designed for good heat transfer from the evaporator to the contents of the pod. The body 158 of the pod 150 is made of aluminum and is between 5 and 50 microns thick. The bodies of some pods are made of other materials, for example, tin, stainless steel, and various polymers such as Polyethylene terephthalate (PTE).

30

[0105] Pod 150 may be made from a combination of different materials to assist with the manufacturability and performance of the pod. In one embodiment, the pod walls and the second end 212 may be made of Aluminum 3104 while the base may be made of Aluminum 5182.

5 [0106] In some pods, the internal components of the pod are coated with a lacquer to prevent corrosion of the pod as it comes into contact with the ingredients contained within pod. This lacquer also reduces the likelihood of “off notes” of the metal in the food and beverage ingredients contained within pod. For example, a pod made of aluminum may be internally coated with one or a combination of the following coatings:
10 Sherwin Williams/Valspar V70Q11, V70Q05, 32SO2AD, 40Q60AJ; PPG Innovel 2012-823, 2012-820C; and/or Akzo Nobel Aqualure G1 50. Other coatings made by the same or other coating manufacturers may also be used.

[0107] Some mixing paddles are made of similar aluminum alloys and coated with similar lacquers/coatings. For example, Whitford/PPG coating 8870 may be used as
15 a coating for mixing paddles. The mixing paddle lacquer may have additional non-stick and hardening benefits for mixing paddle.

[0108] Figures 7A – 7C illustrate the engagement between the driveshaft 126 of the machine 100 and the mixing paddle 160 of a pod 150 inserted in the machine 100. Figures 7A and 7B are perspective views of the pod 150 and the driveshaft 126. In use,
20 the pod 150 is inserted into the receptacle 110 of the evaporator 108 with the first end 210 of the pod 150 downward. This orientation exposes the second end 212 of the pod 150 to the driveshaft 126 as shown in Figure 7A. Closing the lid 112 (see Figure 1A) presses the driveshaft 126 against the second end 212 of the pod 150 with sufficient force that the driveshaft 126 pierces the second end 212 of the pod 150. Figure 7B shows the resulting
25 hole exposing the mixing paddle 160 with the driveshaft 126 offset for ease of viewing. Figure 7C is a cross-section of a portion of the pod 150 with the driveshaft 126 engaged with the mixing paddle 160 after the lid is closed. Typically, there is not a tight seal between the driveshaft 126 and the pod 150 so that air can flow in as the frozen confection is evacuating/dispensing out the other end of the pod 150. In an alternative

embodiment, there is a tight seal such that the pod 150 retains pressure in order to enhance contact between the pod 150 and evaporator 108.

[0109] Some mixing paddles contain a funnel or receptacle configuration that receives the punctured end of the second end of the pod when the second end is
5 punctured by driveshaft.

[0110] Figure 8 shows the first end 210 of the pod 150 with the cap 166 spaced apart from the base 162 for ease of viewing. Figures 9A – 9D illustrate rotation of the cap 166 around the first end 210 of the pod 150 to cut and carry away protrusion 165 of base 162 and expose aperture 164 extending through the base 162.

[0111] The base 162 is manufactured separately from the body 158 of the pod 150 and then attached (for example, by crimping or seaming) to the body 158 of the pod 150 covering an open end of the body 158. The protrusion 165 of the base 162 can be formed, for example, by stamping, deep drawing, or heading a sheet of aluminum being used to form the base. The protrusion 165 is attached to the remainder of the base 162, for
10 example, by a weakened score line 173. The scoring can be a vertical score into the base of the aluminum sheet or a horizontal score into the wall of the protrusion 165. For example, the material can be scored from an initial thickness of 0.008 inches to 0.010 inches to a post-scoring thickness of 0.001 inches - 0.008 inches. In an alternative embodiment, there is no post-stamping scoring but rather the walls are intentionally
15 thinned for ease of rupture. In another version, there is not variable wall thickness but rather the cap 166 combined with force of the machine dispensing mechanism engagement are enough to cut the 0.008 inches to 0.010 inches wall thickness on the protrusion 165. With the scoring, the protrusion 165 can be lifted and sheared off the base 162 with 5-75 pounds of force, for example between 15-40 pounds of force.

[0112] The cap 166 has a first aperture 222 and a second aperture 224. The first aperture approximately matches the shape of the aperture 164. The aperture 164 is exposed and extends through the base 162 when the protrusion 165 is removed. The second aperture 224 has a shape corresponding to two overlapping circles. One of the overlapping circles has a shape that corresponds to the shape of the protrusion 165 and
20 the other of the overlapping circles is slightly smaller. A ramp 226 extends between the

outer edges of the two overlapping circles. There is an additional 0.020" material thickness at the top of the ramp transition. This extra height helps to lift and rupture the protrusion's head and open the aperture during the rotation of the cap as described in more detail with reference to Figures 9A – 9G.

5 [0113] As shown in Figures 9A and 9B, the cap 166 is initially attached to the base 162 with the protrusion 165 aligned with and extending through the larger of the overlapping circles of the second aperture 224. When the processor 122 of the machine activates the electric motor 146 to rotate the gear 168 and the annular member 161, rotation of the cap 166 slides the ramp 226 under a lip of the protrusion 165 as shown in
10 Figures 9C and 9D. Continued rotation of the cap 166 applies a lifting force that separates the protrusion 165 from the remainder of the base 162 (see Figures 9E – 9G) and then aligns the first aperture 222 of the cap 166 with the aperture 164 in the base 162 resulting from removal of the protrusion 165.

[0114] Some pods include a structure for retaining the protrusion 165 after the
15 protrusion 165 is separated from the base 162. In the pod 150, the protrusion 165 has a head 167, a stem 169, and a foot 171 (best seen in Figure 9G). The stem 169 extends between the head 167 and the foot 171 and has a smaller cross-section than the head 167 and the foot 171. As rotation of the cap 166 separates the protrusion 165 from the remainder of the base 162, the cap 166 presses laterally against the stem 169 with the
20 head 167 and the foot 171 bracketing the cap 166 along the edges of one of the overlapping circles of the second aperture 224. This configuration retains the protrusion 165 when the protrusion 165 is separated from the base 166. Such a configuration reduces the likelihood that the protrusion falls into the waiting receptacle that when the protrusion 165 is removed from the base.

25 [0115] Some pods include other approaches to separating the protrusion 165 from the remainder of the base 162. For example, in some pods, the base has a rotatable cutting mechanism that is riveted to the base. The rotatable cutting mechanism has a shape similar to that described relative to cap 166 but this secondary piece is riveted to and located within the perimeter of base 162 rather than being mounted over and around
30 base 162. When the refrigeration cycle is complete, the processor 122 of the machine

activates an arm of the machine to rotate the riveted cutting mechanism around a rivet. During rotation, the cutting mechanism engages, cuts and carries away the protrusion 165, leaving the aperture 164 of base 162 in its place.

[0116] In another example, some pods have caps with a sliding knife that moves
5 across the base to remove the protrusion. The sliding knife is activated by the machine and, when triggered by the controller, slides across the base to separate, remove, and collect the protrusion 165. The cap 166 has a guillotine feature that, when activated by the machine, may slide straight across and over the base 162. The cap 166 engages, cuts,
10 and carries away the protrusion 165. In another embodiment, this guillotine feature may be central to the machine and not the cap 166 of pod 150. In another embodiment, this guillotine feature may be mounted as a secondary piece within base 162 and not a secondary mounted piece as is the case with cap 166.

[0117] Some pods have a dispensing mechanism that includes a pop top that can be engaged and released by the machine. When the refrigeration cycle is complete, an
15 arm of the machine engages and lifts a tab of the pod, thereby pressing the puncturing the base and creating an aperture in the base. Chilled or frozen product is dispensed through the aperture. The punctured surface of the base remains hinged to base and is retained inside the pod during dispensing. The mixing avoids or rotates over the punctured surface or, in another embodiment, so that the mixing paddle continues to rotate without
20 obstruction. In some pop tops, the arm of the machine separates the punctured surface from the base.

[0118] Figure 10 is an enlarged schematic side view of the pod 150. The mixing paddle 160 includes a central stem 228 and two blades 230 extending from the central stem 228. The blades 230 are helical blades shaped to churn the contents of the pod 150
25 and to remove ingredients that adhere to inner surface of the body 158 of the pod 150. Some mixing paddles have a single blade and some mixing paddles have more than two mixing paddles.

[0119] Fluids (for example, liquid ingredients, air, or frozen confection) flow through openings 232 in the blades 230 when the mixing paddle 160 rotates. These
30 openings reduce the force required to rotate the mixing paddle 160. This reduction can be

significant as the viscosity of the ingredients increases (e.g., as ice cream forms). The openings 232 further assist in mixing and aerating the ingredients within the pod.

[0120] The lateral edges of the blades 230 define slots 234. The slots 234 are offset so that most of the inner surface of the body 158 is cleared of ingredients that
5 adhere to inner surface of the body by one of the blades 230 as the mixing paddle 160 rotates. Although the mixing paddle is 160 wider than the first end 210 of the body 158 of the pod 150, the slots 234 are alternating slots that facilitate insertion of the mixing
paddle 160 into the body 158 of the pod 150 by rotating the mixing paddle 160 during
insertion so that the slots 234 are aligned with the first end 210. In another embodiment,
10 the outer diameter of the mixing paddle are less than the diameter of the pod 150
opening, allowing for a straight insertion (without rotation) into the pod 150. In another
embodiment, one blade on the mixing paddle has an outer-diameter that is wider than the
second blade diameter, thus allowing for straight insertion (without rotation) into the pod
150. In this mixing paddle configuration, one blade is intended to remove (e.g., scrape)
15 ingredients from the sidewall while the second, shorter diameter blade, is intended to
perform more of a churning operation.

[0121] Some mixing paddles have one or more blades that are hinged to the
central stem. During insertion, the blades can be hinged into a condensed formation and
released into an expanded formation once inserted. Some hinged blades are fixed open
20 while rotating in a first direction and collapsible when rotating in a second direction,
opposite the first direction. Some hinged blades lock into a fixed, outward, position once
inside the pod regardless of rotational directions. Some hinged blades are manually
condensed, expanded, and locked.

[0122] The mixing paddle 160 rotates clockwise and removes frozen confection
25 build up from the pod 214 wall. Gravity forces the confection removed from the pod wall
to fall towards first end 210. In the counterclockwise direction, the mixing paddle 160
rotate, lift and churn the ingredients towards the second end 212. When the paddle
changes direction and rotates clockwise the ingredients are pushed towards the first end
210. When the protrusion 165 of the base 162 is removed as shown and described with
30 respect to Figure 9D, clockwise rotation of the mixing paddle dispenses produced food or

drink from the pod 150 through the aperture 164. Some paddles mix and dispense the contents of the pod by rotating a first direction. Some paddles mix by moving in a first direction and a second direction and dispense by moving in the second direction when the pod is opened.

5 [0123] The central stem 228 defines a recess 236 that is sized to receive the driveshaft 126 of the machine 100. The recess and driveshaft 126 have a square cross section so that the driveshaft 126 and the mixing paddle 160 are rotatably constrained. When the motor rotates the driveshaft 126, the driveshaft rotates the mixing paddle 160. In some embodiments, the cross section of the driveshaft is a different shape and the
10 cross section of the recess is compatibly shaped. In some cases the driveshaft and recess are threadedly connected. In some pods, the recess contains a mating structure that grips the driveshaft to rotationally couple the driveshaft to the paddle.

[0124] Figure 11 is a flow chart of a method 250 implemented on the processor 122 for operating the machine 100. The method 250 is described with references to
15 refrigeration system 109 and machine 100. The method 250 may also be used with other refrigeration systems and machines. The method 250 is described as producing soft serve ice cream but can also be used to produce other cooled or frozen drinks and foods.

[0125] The first step of the method 250 is to turn the machine 100 on (step 260) and turn on the compressor 186 and the fans associated with the condenser 180 (step
20 262). The refrigeration system 109 then idles at regulated temperature (step 264). In the method 250, the evaporator 108 temperature is controlled to remain around 0.75°C but may fluctuate by $\pm 0.25^\circ\text{C}$. Some machines are operated at other idle temperatures, for example, from 0.75°C to room temperature (22.0°C). If the evaporator temperature is below 0.5°C, the processor 122 opens the bypass valve 190 to increase the heat of the
25 system (step 266). When the evaporator temperature goes over 1°C, the bypass valve 190 is closed to cool the evaporator (step 268). From the idle state, the machine 100 can be operated to produce ice cream (step 270) or can shut down (step 272).

[0126] After inserting a pod, the user presses the start button. When the user presses the start button, the bypass valve 190 closes, the evaporator 108 moves to its
30 closed position, and the motor 124 is turned on (step 274). In some machines, the

evaporator is closed electronically using a motor. In some machines, the evaporator is closed mechanically, for example by the lid moving from the open position to the closed position. In some systems, a sensor confirms that a pod 150 is present in the evaporator 108 before these actions are taken.

5 [0127] Some systems include radio frequency identification (RFID) tags or other intelligent bar codes such as UPC bar or QR codes. Identification information on pods can be used to trigger specific cooling and mixing algorithms for specific pods. These systems can optionally read the RFID, QR code, or barcode and identify the mixing motor speed profile and the mixing motor torque threshold (step 273).

10 [0128] The identification information can also be used to facilitate direct to consumer marketing (e.g., over the internet or using a subscription model). This approach and the systems described in this specification enable selling ice cream thru e-commerce because the pods are shelf stable. In the subscription mode, customers pay a monthly fee for a predetermined number of pods shipped to them each month. They can
15 select their personalized pods from various categories (e.g., ice cream, healthy smoothies, frozen coffees or frozen cocktails) as well as their personalized flavors (e.g., chocolate or vanilla).

[0129] The identification can also be used to track each pod used. In some systems, the machine is linked with a network and can be configured to inform a vendor
20 as to which pods are being used and need to be replaced (e.g., through a weekly shipment). This method is more efficient than having the consumers go to the grocery store and purchase pods.

[0130] These actions cool the pod 150 in the evaporator 108 while rotating the mixing paddle 160. As the ice cream forms, the viscosity of the contents of the pod 150
25 increases. A torque sensor of the machine measures the torque of the motor 124 required to rotate the mixing paddle 160 within the pod 150. Once the torque of the motor 124 measured by a torque sensor satisfies a predetermined threshold, the machine 100 moves into a dispensing mode (276). The dispensing port opens and the motor 124 reverses direction (step 278) to press the frozen confection out of the pod 150. This continues for
30 approximately 1 to 10 seconds to dispense the contents of the pod 150 (step 280). The

machine 100 then switches to defrost mode (step 282). Frost that builds up on the evaporator 108 can reduce the heat transfer efficiency of the evaporator 108. In addition, the evaporator 108 can freeze to the pod 150, the first portion 128 and second portion 130 of the evaporator can freeze together, and/or the pod can freeze to the evaporator. The evaporator can be defrosted between cycles to avoid these issues by opening the bypass valve 170, opening the evaporator 108, and turning off the motor 124 (step 282). The machine then diverts gas through the bypass valve for about 1 to 10 seconds to defrost the evaporator (step 284). The machine is programmed to defrost after every cycle, unless a thermocouple reports that the evaporator 108 is already above freezing. The pod can then be removed. The machine 100 then returns to idle mode (step 264). In some machines, a thermometer measures the temperature of the contents of pod 150 and identifies when it is time to dispense the contents of the pod. In some machines, the dispensing mode begins when a predetermined time is achieved. In some machines, a combination of torque required to turn the mixing paddle, mixing motor current draw, temperature of the pod, and/or time determines when it is time to dispense the contents of the pod.

[0131] If the idle time expires, the machine 100 automatically powers down (step 272). A user can also power down the machine 100 by holding down the power button (286). When powering down, the processor opens the bypass valve 190 to equalize pressure across the valve (step 288). The machine 100 waits ten seconds (step 290) then turns off the compressor 186 and fans (step 292). The machine is then off.

[0132] Figure 12 is a schematic of a refrigeration system 310 that includes the evaporator 108 and an expansion sub-system 312. The refrigeration system 310 is substantially similar to the refrigeration system 109. However, the refrigeration system 310 includes the expansion sub-system 312 rather than the expansion valve 184 shown in the refrigeration system 109. The refrigeration system 310 does not include the first bypass line 188 and the second bypass line 190 that are part of the refrigeration system 109. However, some systems include the with the expansion sub-system 312, the first bypass line, and the second bypass line.

[0133] The expansion sub-system 312 includes multiple valves to control expansion of the refrigeration fluid. These valves include a first fixed orifice valve 314, a

second fixed orifice valve 316, and a control valve 318. The control valve 318 is upstream from the second fixed orifice valve 316. The control valve 318 and second fixed orifice valve 316 are in parallel with the first fixed orifice valve 314. The expansion device has two modes to control the temperature of the refrigerant entering the evaporator 108. In the first mode, the control valve 318 is open allowing the refrigerant to flow to the second fixed orifice valve 316. In the first mode, the refrigerant flows through both the first fixed orifice valves 314 and the second fixed orifice valves 316. In the second mode, the control valve 318 is closed and the refrigerant does not flow through the second fixed orifice valve 316. All refrigerant flows through the first fixed orifice valve 314.

[0134] As discussed with reference to Figure 4, the expansion valve 184 or expansion sub-system 312 receives a high-pressure refrigerant and releases low-pressure refrigerant. This pressure drop cools the refrigerant. Larger changes in pressure (ΔP) cause larger changes in temperature (ΔT). In the second mode (i.e., with control valve 318 closed), the pressure drop through the expansion sub-system 312 will be higher than in the first mode providing a lower evaporator pressure and associated lower evaporator temperature. The effect on heat transfer of the increased temperature differential between the refrigerant and the contents of a pod in the evaporator 108 is offset to some extent by the fact that this lower pressure refrigerant is less dense. Since the compressor moves a fixed volume of refrigerant each compression cycle, the mass flow per cycle is reduced, which lowers heat transfer. In the second mode of operation, there is a big temperature difference between the pod and evaporator, requiring large heat transfer, which increases the amount of mass flow needed.

[0135] During initial operation, the refrigeration system 310 is in the first mode. The control valve 318 is open and the refrigerant flows through both the first fixed orifice valve 314 and second fixed orifice valve 316. This results in the evaporator operating at around a temperature of $-20\text{ }^{\circ}\text{C}$ to $-10\text{ }^{\circ}\text{C}$. At this temperature, the cooling system provides more cooling capacity than it can at lower temperatures by taking advantage of the higher density refrigerant passing through the evaporator.

[0136] The pod 150 is inserted into the evaporator 108 around room temperature (e.g., 22°C). The initial difference in temperature between the evaporator 108 and the pod 150 is high. As a result, the heat transfers rapidly from the pod 150 to the evaporator 108. The difference between the temperature of the pod 150 and the evaporator 108 decreases as the pod 150 cools and the transfer of heat from the pod 150 to the evaporator 108 also slows. At this point, the system 310 enters the second mode and the control valve 318 closes. The refrigerant flows only through the first fixed orifice valve 314 and the ΔP between the refrigerant entering the first fixed orifice valve 314 and exiting the first fixed orifice valve 314 increases. The ΔT also increases resulting in a colder evaporator 108 with temperatures of approximately -15 °C to -30°C. This reduces the cooling capacity of the system, but increases the temperature difference between the pod and nest, which allows for quick final freezing of the ice cream. In the second mode activated when the temperature difference between the pod and evaporator reduces to the point of impacting heat transfer, the lower refrigerant temperature augments the overall heat transfer even through less mass is flowing in the system.

[0137] In some embodiments, the temperature of the evaporator in the first mode is above freezing. This configuration can precool the evaporator before use and defrost the evaporator after use.

[0138] The configuration of the refrigeration system 310 increases temperature control, which can reduce freezing time and reduce the required compressor output. The reduction in required compressor output allows for a reduction in the size of the compressor.

[0139] In some refrigeration systems, the expansion sub-system includes more than two valves. The multi-valve sub-systems can have more than two modes, further increasing temperature control.

[0140] In some refrigeration systems use other types of valves such as, for example, thermostatic expansion valves and electronic expansion valves. Both thermostatic expansion valves and electronic expansion valves can adapt the orifice size based on various loads and operating conditions. For example, the thermostatic expansion valves sense the evaporator outlet temperature of the refrigerant and adjusts

flow through the thermostatic expansion valve to maintain predetermined or desired operating conditions. The electronic expansion valves are electrically actuated to adapt the orifice size based on evaporator outlet temperature and electronic signals from a control unit 371.

5 [0141] Figure 13 is a schematic of a refrigeration system 320 that includes a refrigerant line 322 that pre-chills a tank 324 of water prior to entering the evaporator 108. The refrigeration system 320 is substantially similar to the refrigeration system 109. However, the refrigeration system 320 includes the pre-chilling line 322 and omits the first bypass line 188 and the second bypass line 190 that are part of the refrigeration
10 system 109. Some systems include the first bypass line, the second bypass line, and the pre-chilling line.

[0142] The refrigeration system 320 is used in machines include the water tank 324. Machines with water tanks inject fluid into the pod during mixing, for example, to dissolve dry ingredients or dilute the contents of the pod. Chilled water freezes more
15 quickly than hot or room temperature water.

[0143] In use, a valve 326 is operated to route refrigerant through pre-chilling to route refrigerant exiting the expansion valve 184 through the pre-chilling line 322. The cold, low-pressure refrigerant flows through the pre-chilling line 322 that is partially or fully disposed in the water tank 324. If the water tank 324 is filled with water, the pre-chilling
20 line 322 is partially or fully submerged in the water. The refrigerant cools the water in the water tank 324 and exits the pre-chilling line 322. The refrigerant then enters the evaporator 108 to cool the evaporator 108.

[0144] Figure 14 is a schematic of a refrigeration system 328 that includes a thermal mass 330 disposed between the compressor 186 and the condenser 180. The
25 refrigeration system 328 is substantially similar to the refrigeration system 109. However, the refrigeration system 328 includes the thermal mass 330. The refrigeration system 328 does not include the first bypass line 188 and the second bypass line 190 that are part of the refrigeration system 109. Some systems include the first bypass line, the second bypass line, and the thermal mass 330.

[0145] The thermal mass may be, for example, ethylene glycol and water mixture, saltwater, paraffin wax (alkanes) or pure water. In some machines, the thermal mass 330 is disposed between the condenser 180 and heat exchanger 182.

[0146] The thermal mass 330 stores thermal energy and releases thermal energy at a later time. When disposed on between the compressor 186 and the condenser 180, the thermal mass 330 stores heat emitted from the refrigerant. At this point in the cycle, the refrigerant is a high-pressure vapor. The condenser 180 isothermally releases heat from the high-pressure vapor to produce a high-pressure liquid. Precooling the vapor refrigerant with the thermal mass 330 reduces the load of the compressor 186. When the machine 100 powers down, the thermal mass 330 releases heat into the environment and reaches an equilibrium at ambient temperatures.

[0147] Some systems include both the second bypass line and the thermal mass. The second bypass line redirects refrigerant from the thermal mass, idling the refrigeration system. During this idling period, the thermal mass releases heat from previous cycles into the environment.

[0148] Figure 15 is a schematic of a refrigeration system 332 that includes a pressure vessel 334, a first control valve 336, and a second control valve 338. The pressure vessel 334 can act as pressure reservoir that enables rapid startup of the system and decreases the time required to cool (e.g., to freezing) contents of a pod in the evaporator 108. The refrigeration system 332 is substantially similar to the refrigeration system 109. However, the refrigeration system 332 includes the pressure vessel 334, the first control valve 336, and the second control valve 338. The refrigeration system 332 further does not include the first bypass line 188 and the second bypass line 190 that are part of the refrigeration system 109. Some systems include the first bypass line, the second bypass line, the pressure vessel 334, the first control valve 336, and the second control valve 338.

[0149] The first control valve 336 is disposed between the compressor 186 and the condenser 180. The second control valve 338 is disposed between the heat exchanger 182 and the expansion valve 184. The pressure vessel 334 is disposed between the condenser 180 and the heat exchanger 182. The refrigerant exits the compressor 186 at a

high-pressure and maintains that high-pressure until the liquid refrigerant is released by the expansion valve 184. The system 332 controls the position of the valves 336, 338 (e.g., open or closed) based on the desired outcome.

[0150] During normal operation of the system 332 (e.g., when cooling pods), both
5 the first control valve 336 and the second control valve 338 are open. Prior to idling, the second control valve 338 closes and the first control valve 336 remains open. The compressor 186 continues to run for a short time, for example, 1 – 5 seconds, before the first control valve 336 closes. After the first control valve 336 closes, the compressor shuts down.

[0151] When the system 332 is reactivated (e.g., to produce a serving of a cooled
10 food or drink), the compressor 186 restarts, the first control valve 336 opens, and the second control valve 338 opens. Because high-pressure fluid is already present in the pressure vessel 334, high-pressure refrigerant flows through the expansion valve 184 with the pressure drop cooling the refrigerant. This approach decreases the time required to
15 cool the contents of a pod relative to refrigeration systems that allow to system pressures to return to ambient conditions when shutting down. If the system is at ambient conditions, no pressure drop occurs across the expansion valve initially when restarting the system. This approach has demonstrated to decrease the time required to cool the contents of a 8-ounce pod from room temperature to freezing to less than 90 seconds.
20 The refrigeration system 332 is able to cool the refrigerant quickly or instantaneously when the system 332 initiates or boots up, for example prior to the insertion of a pod 150.

[0152] Figure 16 is a schematic of a refrigeration system 340 that includes a thermoelectric module 342. The refrigeration system 340 is substantially similar to the refrigeration system 109. However, does not include the first bypass line 188 and the
25 second bypass line 190 that are part of the refrigeration system 109. Some systems include the first bypass line, the second bypass line, and thermoelectric module 342.

[0153] Thermoelectric module 342 is a cooling element disposed between the condenser 180 and the heat exchanger 182. The thermoelectric module 342 cools the refrigerant that exits the condenser 180 prior to transferring heat to the refrigerant vapor
30 exiting the evaporator 108 in the heat exchanger 182. Cooling the liquid refrigerant prior

to expansion increases the cooling capacity of the system 340 and reduce the required compressor output. The reduction in required compressor output reduces the size of the compressor needed.

[0154] Figure 17 is a schematic of a refrigeration system 344 that includes a thermal battery 346, a first battery bypass valve 348, and a second battery bypass valve 350. The refrigeration system 344 is substantially similar to the refrigeration system 109 but does not include the first bypass line 188 that is part of the refrigeration system 109. Some systems with the thermal battery 346 and associated valves also includes the first bypass line.

[0155] The thermal battery 346 has a first portion 352 that is disposed between the heat exchanger 182 and the expansion valve 184. The first battery bypass valve 348 is disposed on a first branch line 354 that bypasses the first portion 352 of the thermal battery 346. When the first battery bypass valve 348 is open, a majority or all the refrigerant flows through the first branch line 354. The thermal battery 346 has a high pressure drop. The refrigerant primarily flows through the branch line 354 because the branch line 354 has a comparatively low pressure drop to the thermal battery 346. When the first battery bypass valve 348 is closed, the refrigerant flows through the first portion 352 of the thermal battery 346.

[0156] The thermal battery 346 has a second portion 356, thermally connected to the first portion 352, that is disposed between the evaporator 108 and the heat exchanger 182. The second battery bypass valve 350 is disposed on a second branch line 358 that bypasses the second portion 356 of the thermal battery 346. When the second battery bypass valve 350 is open a majority or all of the refrigerant flows through the second branch line 358. The thermal battery 346 has a high pressure drop. The refrigerant primarily flows through the branch line 358 because the branch line 358 has a comparatively low pressure drop to the thermal battery 346. When the second battery bypass valve 350 is closed, the refrigerant flows through the second portion 356 of the thermal battery 346.

[0157] The thermal battery 346 includes a thermal material that retains heat. The thermal battery 346 includes a reservoir 360 with a phase change material (e.g., paraffin)

receives heat or emits heat, depending on the position of the first battery bypass valve 348 and the second battery bypass valve 350. The thermal battery 346 is described as using paraffin as an example of a phase change material. Some thermal batteries include other materials that retain heat or expend heat, for example ethylene glycol and water mixture, saltwater or pure water.

[0158] The thermal battery 346 emits heat from its second portion 356 to the refrigerant when the first battery bypass valve 348 is open and the second battery bypass valve 350 is closed. If the paraffin is warm or melted, the cold refrigerant will chill and solidify the paraffin in the reservoir 360. By heating the low-pressure refrigerant, the thermal battery reducing the likelihood that liquid refrigerant will flow into the compressor.

[0159] The thermal battery 346 receives heat at the first portion 352 from the refrigerant when the first battery bypass valve 348 is closed and the second battery bypass valve 350 is open. If the wax is solidified, the hot liquid refrigerant will heat and melt the wax in the wax reservoir 360. If the wax is liquid, the hot refrigerant will continue to heat the liquid wax in the wax reservoir 360.

[0160] On activation of the system 344 and during the cooling cycle, both the first battery bypass valve 348 and the second battery bypass valve 350 are open and little to no refrigerant flows interacts with the thermal battery 346. At the end of the cooling cycle, the second battery bypass valve 350 closes and the reservoir 360 cools due to the cold, low-pressure refrigerant. As the next cycle begins with a cooled battery, the second battery bypass valve 350 opens, and the first battery bypass valve 348 closes. The first portion 352 of the thermal battery 346 then pre-cools the hot liquid refrigerant exiting the condenser 180 via the heat exchanger 182.

[0161] This configuration can prevent end-of-cycle compressor flooding and can reduce the output of the compressor by reducing the heat load on the compressor. Some waxes may have a melting point in a range of 5°C - 10°C, for example, Dodecane wax or Tridecane wax.

[0162] Figure 18A is top view of an evaporator cover 127 and Figure 18B is a top view of the body of the evaporator 108. The body of the evaporator 108 defines the

channels 366 through which refrigerant flows to cool the evaporator 108. The channels 366 are open at a lip 367, as shown in Figure 18B, of the evaporator 108. The channels 366 are also open at the opposite end of the evaporator 108 with a similarly configured lip.

5 [0163] The cover 127 includes multiple recesses 174 that align with four adjacent channels 366 of the evaporator 108 when the cover 127 is attached to the body of the evaporator 108. Some covers include recesses that align with other numbers of adjacent channels. The recesses 174 act as manifolds fluidly connect the adjacent channels 366. The cover 127 on the opposite ends of the body of the evaporator are offset so that the
10 two covers 127 and the body of the evaporator 108 together define a serpentine flow path through the evaporator 108.

[0164] The cover 127 has an inlet 370 and an outlet 372 that fluidly connects the evaporator 108 to the refrigeration system 109. Refrigerant flows through the inlet 370, through the channels defined by recesses in the body of the evaporator 108 and the cover
15 127, and exits the evaporator 108 through the outlet 372. The refrigerant enters the inlet 370 as a cold fluid at a first temperature. As the refrigerant flows through the flow path 368, the refrigerant warms and evaporates due to the heat received by the evaporator 108 from the pod 150. The pod 150 freezes due to this heat transfer. To maintain a constant flow speed, the inlet 370 is about 0.25 inches in diameter and the outlet 372 is about 0.31
20 inches in diameter.

[0165] The living hinge 132 defines a connecting channel 373 that fluidly connects channels in the first portion 128 of the evaporator 108 to channels 366 in the second portion 130 of the evaporator 108. The connecting channel 373 is defined within the evaporator 108 near the lip 367 of the evaporator 108. In some evaporators, the lip of
25 the evaporator defines a groove and the lid defines a corresponding groove so that the connecting channel is formed between the groove of the lid and the groove of the evaporator, when the lid and evaporator engage. Some connecting channel are defined within the cover 127. This configuration defines the continuous flow path 368 from the inlet 370 to the outlet 372 in which channels 366 extend parallel to the axis 369 and flow
30 fluid parallel to the axis 369.

[0166] In some evaporators, the channels 366 connect within the evaporator at the opposite end from the lip 367, to form a “U” shape. When assembled, the cover 127 is disposed on the lip 367 of the evaporator 108. The channels 366 are a series of unconnected “U” shaped units. In each unit, a first channel flows the refrigerant in a first direction and a second channel flows the fluid in a second direction, opposite the first direction.

[0167] The channels 366 extend parallel to an axis 369 of the evaporator. In some evaporators, the channels do not extend parallel to the axis but do extend parallel to each other. In some evaporators, the channels do not extend parallel to each other or parallel to the axis.

[0168] Figures 19A and 19B are perspective views of an evaporator 380 without and with, respectively, its cover 127. The evaporator 380 in Figures 19A and 19B operates similarly to the evaporator 108 described in Figures 18A-18E. However, the evaporator 380 includes recesses 382 that fluidly connect the second channel 366b of a unit 371 to a first channel 366a of a different unit 371. The cover 384 is substantially similar to the cover 127. However, the cover 384 is flat rather than recessed on the surface that abuts the lip 367, and includes multiple inlets and outlets, rather than a single inlet and a single outlet. The cover 384 includes a first inlet 388 on the first portion 128, a first outlet 390 on the first portion 128, a second inlet 392 on the second portion 130, and a second outlet 394 on the second portion. The first inlet 388 and first outlet 390 are fluidly connected to form a first flow path 396 on the first portion 128. The second inlet 392 and second outlet 394 fluidly connect to form a second flow path 398 on the second portion 130. This configuration forms two flow paths 396, 398 that flow refrigerant in parallel and does not use a hinge connector. To maintain flow speed, the diameters of the flow paths 396, 398 are reduced such that the divided flow paths have a similar flow area to the originating flow path.

[0169] When the cover 384 engages the evaporator 380, the recesses 382 are closed and the evaporator 380 and cover 384 form the flow paths 396, 398.

[0170] In the previously described evaporators, the units 371 have “One-up/One-down” configurations. In some evaporators, the units define “Two-Up/Two-Down” or

“Three-Up/Three-Down” configurations. This can maintain proper flow speeds while minimizing the pressure drop within evaporator. Different flow path arrangements are needed for different compressors and different cooling tasks. The number of parallel flow paths can be increased for larger compressors and cooling loads and be reduced for smaller requirements.

[0171] Figures 20A-20D are schematic views of flow paths formed by the channels of the evaporator and recesses of its cover 127. Figures 20A and 20B are views of the channels defined within an evaporator. Figures 20C and 20D are perspective views of an evaporator and its cover 127.

[0172] Figure 20A is a flow path 402 that increases the number of channels 400 as the refrigerant evaporates. The refrigerant enters the inlet and flows through one or more single channels 400a. At the refrigerant evaporates, it expands in volume and begins to move faster. The vapor may expand about 50-70 times in specific volume. To slow the mixed-phase refrigerant within the evaporator 108, the flow path 402 branches into two parallel channels 400b that connect at the recesses 374 and within the evaporator 108 at a turning point 306. As the refrigerant evaporates more, the flow path 402 branches again into three parallel channels 400c that connect at the recesses 374 and within the evaporator 108 at the turning point 306. In some evaporators, the “Two-Up/Two-Down” configuration is maintained for multiple units. In some evaporators, the “Three-Up/Three-Down” configuration is maintained for multiple units. In some evaporators, the flow path increase to a “Four-Up/Four-Down” or “Five-Up/Five-Down” configuration. Increasing the number of channels throughout the evaporator increases performance early in the evaporating process while limiting high velocity/pressure drop towards the outlet of the evaporator.

[0173] Figure 20B is a schematic of the flow path 402 with a ramped recess 408 in the cover 127 that acts as a manifold. The ramped recess 408 has a smoothly increasing and decreasing cross-sectional area that helps maintains the flow speed of refrigerant flowing through manifold. A ramped cross section recess in the cover would help maintain flow velocities and also reduce pressure drop and flow separation of liquid and gas refrigerant due to low flow velocity areas.

[0174] Figure 20C shows a flow path 420 that includes a first manifold at the bottom of the evaporator 108 and multiple branches 424 extending towards the cover 127 from the first manifold 422. The first manifold 422 connects to the inlet 370. The branches 424 fluidly connect to a second manifold 426 at the top of the evaporator 108.
5 The second manifold 426 fluidly connects to the outlet 372.

[0175] The refrigerant flows from the inlet through the first manifold 422, up the branches 424, and through the second manifold 426 to the outlet 372. Vapor is less dense than the liquid and tends to rise to the top. This preferential flow direction can create unpredictable flow and performance when flow direction is downward. This
10 configuration can increase thermal performance of the evaporator 108 by flowing refrigerant in the same direction as the buoyancy force present when the refrigerant is in vapor form.

[0176] Figure 20D shows a flow path 430 that winds around the evaporator 108. The flow path 430 is a spiral that follows the outer diameter of the evaporator 108. This
15 configuration increases surface area and reduces pressure drop by reducing or eliminating tight turns in the flow path 430. In some evaporators, multiple hinge connectors are used to connect the first portion of the evaporator and the second portion of the evaporator when the flow path extends across the first and second portion. Some flow paths define a serpentine passage on the first portion and a serpentine passage on the second portion that
20 are connected by a “transit passage” that spans the hinge.

[0177] Figures 21A-21C are views of the pod 150 and an evaporator 438 with a closing mechanism 440. Figure 21A is a perspective view of the evaporator 438 and pod 150. Figure 21B is a cross-sectional view of the pod 150 and the evaporator 438. Figure 21C is a top view of the pod 150 and the evaporator 438.

[0178] The closing mechanism 440 includes biasing elements (e.g. springs) that connects the first portion 128 of the evaporator 438 to the second portion 130 of the evaporator 438. The closing mechanism 440 also includes a circumferential cable 441 that extends around the outer diameter of the evaporator. The cable is tightened close the pod and loosened to open the evaporator.

[0179] The biasing element in evaporator 438 includes a first and second spring 442, 444 that bias the first portion 128 and the second portion 130 away from each other. The living hinge 132 facilitates the movement of the first and second portions 128, 130 such that the first and second portions 128, 130 rotate about the hinge 132 due to the
5 biasing force of the springs 442, 444. In this configuration, the evaporator 438 is in the open position and a small gap 446 forms between the first and second portions 128, 130. The evaporator 438 is in the open position when the cover 127 is in the open position. In some machines, the position of the evaporator is independent from the position of the lid. In the open position, a small air gap exists between the evaporator 438 and the pod 150.

[0180] The evaporator 438 has a closed position in which the airgap between the evaporator 438 and the pod 150 is eliminated to promote heat transfer. In some evaporators, the air gap is simply reduced. In the closed position, the gap 446 is also eliminated. In some evaporators, the gap is reduced rather than eliminated. To move from the open position to the closed position, the closing mechanism 440 applies a force
10 in the direction of arrows 448 to overcome the biasing force of the first and second springs 442, 444.

[0181] The closing mechanism produces a force within the range of 10 to 1500 lbs. To prevent crushing of the pod 150, the internal pressure of the pod 150 is preferably equal to or greater than the force produced by the closing mechanism 440.

[0182] The closing mechanism 440 may be, for example, an electromechanical actuator, a pulley system, a lever, projections on the lid, a ball screw, a solenoid, or a mechanical latch.

[0183] Figures 22A and 22B are, respectively, side and front views of an evaporator 108 with a closing mechanism 440 that includes two bolts 450 inside springs 456. The bolts 450 bias the bar 466 away from flanges 464. Optionally, a cable 468 is
25 received in a hole defined in the bar 466 and extends around the evaporator 108.

[0184] Figure 23A shows an evaporator 500 that can be produced primarily by extrusion. The evaporator 500 has a body 510 with two end caps 512. The body 510 and the end caps are produced separately and then assembled.

[0185] Figures 23B and 23C illustrate production of the body 510. The evaporator body 510 is produced by low cost extrusion. The body is extruded with the channels 514 defined in the body 510 (see Figure 23B). Each end of the body 510 is machined to provide a shoulder 516 that mates with an end cap (see Figure 23C). A wall 518 extends beyond the shoulder 516.

[0186] Figures 23D and 23E are perspective views of an end cap 512. The end caps 512 can be forged or machined. The end caps 512 provide the mounting, inlet/outlet, and closure features of the evaporator 500. The end cap 512 has a sidewall 520 and an end wall 522.

[0187] The end cap 512 has multiple bosses 524 extending outward from the sidewall 520. The bosses 524 can be used for mounting and handling the end cap 512 and, after assembly with the body 510, the evaporator 500. A port 526 extends through the sidewall 520. The port 526 of the end cap 512 on one end of the evaporator 500 is used as an inlet and the port 526 of the end cap 512 on the other end of the evaporator 500 is used as an outlet.

[0188] Figure 23F illustrates assembly of the evaporator 500. The end cap 512 is mounted on the shoulder 516 on one end of the body 510. After mounting, the joints between the evaporator body 510 and the end caps 512 are easily accessible. This configuration facilitates use of used for laser welding, vacuum brazing, friction stir welding or TIG welding to attach the end caps 512 to the evaporator body 510.

[0189] Figures 23G and 23H illustrate the relationship between the body 510 and the end cap 512 after assembly. When assembled with the body 510, the sidewall 520 and the end wall 522 of the end cap and the wall 518 of the body 510 define a chamber that acts as a manifold connecting the channels defined in the body 510 of the evaporator 500. The end cap 512 is shown with "hollow" configuration for evaporating up with all passages in parallel but it could be adapted for a multipath design with multiple 180 degree turnarounds.

[0190] Figure 24 shows a configuration of the evaporator 500 that incorporates an orifice plate 530. The orifice plate 530 is disposed between the body 510 and the end cap 512. The orifice plate 530 defines multiple orifices 532 that, after assembly, are aligned

with the channels 514 in the body 510. The orifice plate can be used to distribute flow evenly to the channels 514 by accumulating refrigerant prior to the orifice plate 530 and injecting liquid-gas mixture equally to the channels 524. In some cases, the orifices are identical in size. In some cases, where there is likely to be maldistribution of flow between passages 514, the orifices can be different sizes..

[0191] Figure 25 is a perspective view of an embodiment of the evaporator 380 described with reference to Figures 19A and 19B with an internal surface 470 made of a different material than the remainder of the evaporator 380. The inner surface 470 is mainly or completely formed of copper. Copper has a higher thermal conductivity (approximately 391 W/mK) than aluminum that has a thermal conductivity of 180 W/mK. A high thermal conductivity moves heat quickly and efficiently from the pod to the refrigerant. A material with low thermal conductivity pass heat slower and with less efficiency. The tendency of a component to act as a heat sink is a function of both its thermal conductivity and its mass. Table 2 lists the thermal conductivity and density of a variety of materials.

Table 2 - Conductivity under standard conditions (atmospheric pressure and 293 degrees Kelvin)	
Material	Thermal conductivity [$W \cdot m^{-1} \cdot K^{-1}$]
Acrylic glass (Plexiglas V045i)	0.170 – 0.200
Alcohols, oils	0.100
Aluminium	237
Alumina	30
Boron arsenide	1,300
Copper (pure)	401
Diamond	1,000
Fiberglass or foam-glass	0.045
Polyurethane foam	0.03
Expanded polystyrene	0.033 - 0.046
Manganese	7.810
Water	0.5918
Marble	2.070 – 2.940
Silica aerogel	0.02
Snow (dry)	0.050 – 0.250
Teflon	0.250

[0192] Figures 26A-26C are schematic views of claddings. These claddings can be used in an evaporator that includes both aluminum and copper. Figure 26A shows an overlay cladding 490. Figure 26B shows an inlay clad 492. Figure 26C shows an edge clad 495. Cladding techniques as shown in Figures 26A-26C are applied to the inner
5 surface of the evaporator. Different clad techniques can increase heat transfer and spread heat out, due to the high thermal conductivity of copper.

[0193] Figure 27 is an exemplary view of a material 480 that includes microchannels 482. When the material 480 is used to make, for example, evaporators, refrigerant flows through the microchannels 482. The material 480 can be bent to form
10 an evaporator that cools the pod 150. The material 480 is permanently deformed into a cylindrical shape to create a round evaporator. Such an evaporator has a high surface area which increases evaporator performance while keep costs low.

[0194] Figures 28A-28C show a rotary compressor 550 that is used in some some refrigeration systems instead of the reciprocating compressor 186 previously described.
15 The compressor 550 includes a housing 552 with an interior wall 553 that defines an interior cavity 554. An inlet 556 and an outlet 558 fluidly connect the interior cavity 554 of the compressor 550 to other components of the refrigeration system. A pressure valve 559 releases fluid when the fluid reaches a predetermined pressure. A roller 560 with a circular cross section, is rotationally and axially constrained to a rod 562 that extends
20 through a bottom section of the housing 552. Some rollers have ellipse shaped or gear shaped cross sections. The rod 562 is attached off center from the circular cross section of the roller 560. The rod 562 and roller 560 rotate relative to the housing 557 using a motor (not shown). The roller 560 is arranged in the cavity 554 such that an edge 564 of the roller 560 extends to the interior wall 553 of the housing. In this configuration, the roller
25 560 forms a seal with the housing 557. The edge 564 of the roller 560 maintains contact on the wall 553 as the rod 562 and the roller 560 rotate within the interior cavity 554. The housing 557 includes a notched area 566 for containing a compressed spring 568. The spring 568 abuts the roller 560. A rubber member 570 surrounds a portion of the spring 568 to form a seal that extends from the wall 553 to the roller 560. The spring 568

expands and contracts as the roller 560 rotates within the interior cavity 554, to maintain the seal.

[0195] In Figure 28A, the compressor 550 is in a first state. In Figure 28B, the rotary compressor 550 is in a second state and in Figure 28C, the rotary compressor 550 is in a third state. The rotary compressor 550 moves from the first state to the second state, from the second state to the third state, and from the third state to the first state. In the first state, the roller 560 receives low-pressure pressure cool vapor from the evaporator 108 via the inlet 556. The seal between the contact edge 564 and the wall 553 and the seal between the member 570 and the roller 560 define an intake chamber 572 and a pressurizing chamber 574. In some rotary compressors, additional seals are formed that increase the number of chambers. The roller 560 rotates to compress and pressurize vapor in the pressurizing chamber 574 and to draw in vapor to intake chamber 572 from the inlet 556. In the second state, shown in Figure 28B, the roller 560 continues to rotate counterclockwise and increase the pressure of the vapor in the pressurizing chamber 574 until the pressure valve 559 releases the high-pressure vapor out of the compressor 550. The intake chamber continues to receive low-pressure vapor from the inlet 556. The compressed spring 568 extends into the interior cavity 554 as the roller 560 rotates, to maintain connection between the member 570 and the roller 560. In the third state, shown in Figure 28C, the high-pressure vapor has been expelled from the pressurizing chamber 574 and the spring 568 is compressed into the notched area 566. In this state, only one seal is formed between the contact edge 564 and the member 570. For a brief period in the cycle the number of chambers is reduced by one. At this state in the compressor 550, the intake chamber 572 becomes the pressurizing chamber 574. The intake chamber 572 is reformed when the contact edge 564 passes the member 570 and two seals are formed, one by the member 570 and roller 560 and the other by the contact edge 564 and the wall 553.

[0196] The rotary compressor performs the same thermal duty as the reciprocating compressor at a much lower weight and smaller size. The rotary compressor has a weight of about 10 to about 18 lbs. The rotary compressor has a displacement of refrigerant of

about 4 cc to about 8 cc. The rotary compressor has a performance vs. weight ratio of about 0.3 cc/lb to about 0.5 cc/lb.

[0197] A number of embodiments of the invention have been described.

Nevertheless, it will be understood that various modifications may be made without
5 departing from the spirit and scope of this disclosure invention. Accordingly, other
embodiments are within the scope of the following claims.

WHAT IS CLAIMED IS:

1. A machine for producing cooled food or drinks from ingredients in a pod containing the ingredients, the machine comprising:

an evaporator of a refrigeration system, the evaporator defining a receptacle sized to receive the pod; and

5 wherein the refrigeration system has a working fluid loop that runs from the evaporator to a compressor to a condenser to an expansion valve or capillary tube back to the evaporator and also includes a first bypass line that extends from the working fluid loop between the compressor and the condenser to the working fluid loop between the expansion valve and the evaporator.

10 2. The machine of claim 1, further comprising a bypass valve on the first bypass line.

3. The machine of claim 1, further comprising a second bypass line that extends from the working fluid loop between the compressor and the condenser to the working fluid loop between the evaporator and the compressor.

15 4. The machine of claim 3, further comprising a bypass valve on the second bypass line

5. The machine of claim 3, further comprising a suction line heat exchanger.

6. The machine of claim 5, wherein the working fluid loop passes through a reservoir of phase change material disposed between the compressor and the condenser.

20 7. The machine of claim 6, wherein the phase change material comprises ethylene glycol and water mixture, salt water, paraffin wax, alkanes, or pure water or a combination thereof.

8. The machine of claim 7, wherein the working fluid loop includes a pressure vessel between the condenser and the evaporator, a first isolation valve between the

pressure vessel and the expansion valve, and a second isolation valve between the compressor and the condenser.

9. The machine of claim 8, wherein the working fluid loop passes through a thermoelectric cooler between the condenser and the expansion valve.

5 10. A machine for reducing the temperature of ingredients in a pod containing the ingredients and at least one mixing paddle, the machine comprising:

an evaporator of a refrigeration system, the evaporator defining a receptacle sized to receive the pod;

10 a motor operable to move the at least one internal mixing paddle of a pod in the receptacle;

wherein the refrigeration system has a working fluid loop that runs from the evaporator to a compressor to a condenser to an expansion valve or capillary tube back to the evaporator and also includes a first bypass line that extends from the working fluid loop between the compressor and the condenser to the working fluid loop between the expansion valve and the evaporator and a bypass valve on the first bypass line.

11. The machine of claim 10, further comprising a second bypass line that extends from the working fluid loop between the compressor and the condenser to the working fluid loop between the evaporator and the compressor.

20 12. The machine of claim 11, further comprising a bypass valve on the second bypass line

13. The machine of claim 11, further comprising a suction line heat exchanger

14. The machine of claim 11, wherein the working fluid loop passes through a reservoir of phase change material disposed between the compressor and the condenser.

25 15. The machine of claim 14, wherein the phase change material comprises ethylene glycol and water mixture, salt water, paraffin wax, alkanes or pure water.

16. The machine of claim 10, wherein the working fluid loop includes a pressure vessel between the condenser and the evaporator, a first isolation valve between the pressure vessel and the expansion valve, and a second isolation valve between the compressor and the condenser.

5 17. The machine of claim 10, wherein the working fluid loop passes through a thermoelectric cooler between the condenser and the expansion valve.

18. A machine for producing cooled food or drinks from ingredients in a pod containing the ingredients, the machine comprising:

a housing; and

10 an evaporator of a refrigeration system, the evaporator defining a receptacle sized to receive the pod;

wherein the refrigeration system has a working fluid loop that runs from the evaporator to a compressor to a condenser to an expansion valve or capillary tube back to the evaporator; and

15 wherein the evaporator is made of a material that has at least 160 W/mk thermal conductivity.

19. The machine of claim 18, further comprising an aluminum evaporator with a mass of less than 1.50 pounds.

20 20. The machine of claim 18, further comprising a pressure drop through the refrigeration system less than 2 psi.

21. The machine of claim 18, further comprising a pod to evaporator heat transfer surface of less than 50 square inches.

22. The machine of claim 18, further comprising an evaporator has cooling channels in it allowing for the fluid mass velocity up to 180,000 lb/ (hour feet squared).

25 23. The machine of claim 18, further comprising an evaporator refrigerant wetted surface area of less than 200 square inches.

24. The machine of claim 18, further comprising an evaporator that clamps down on the pod.

25. The machine of claim 18, further comprising an evaporator that has an internal wall of copper adjacent to the pod.

5 26. The machine of claim 18, further comprising an evaporator that is constructed of material defining microchannels.

27. The machine of claim 18, further comprising a bypass line that extends from the working fluid loop between the compressor and the condenser to the working fluid
10 loop between the expansion valve and the evaporator.

28. The machine of claim 18, further comprising a rotary compressor with displacement of refrigerant of less than 6 cubic centimeters.

15 29. The machine of claim 18, further comprising R-290 propane as a refrigerant.

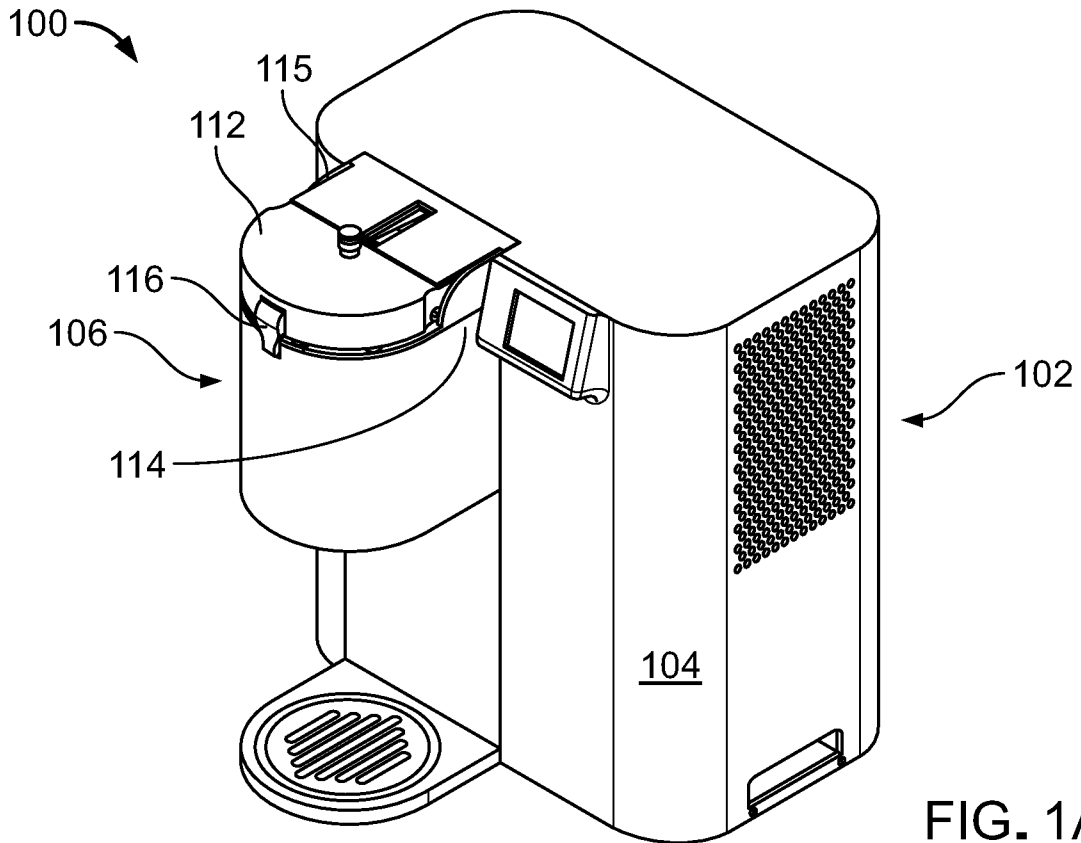

FIG. 1A

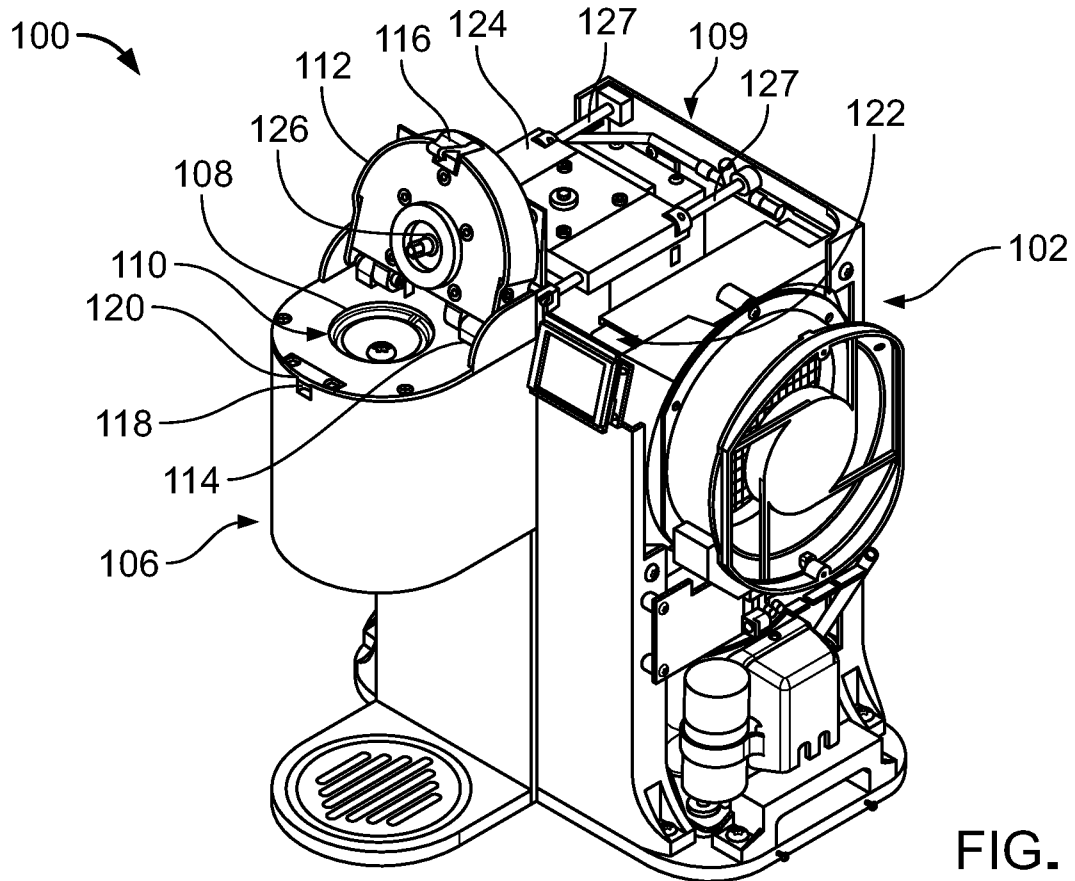

FIG. 1B

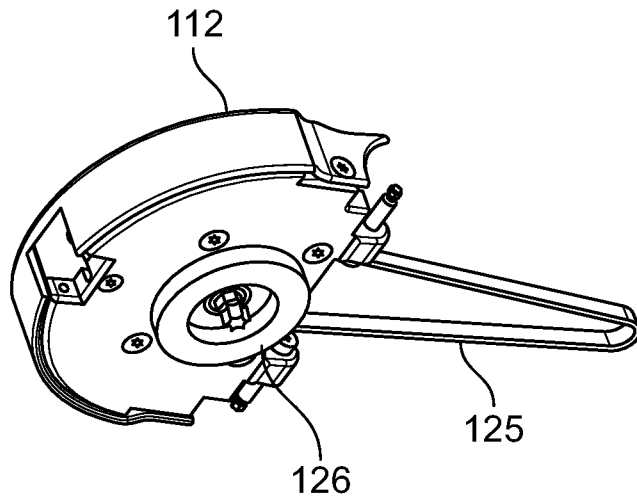

FIG. 1C

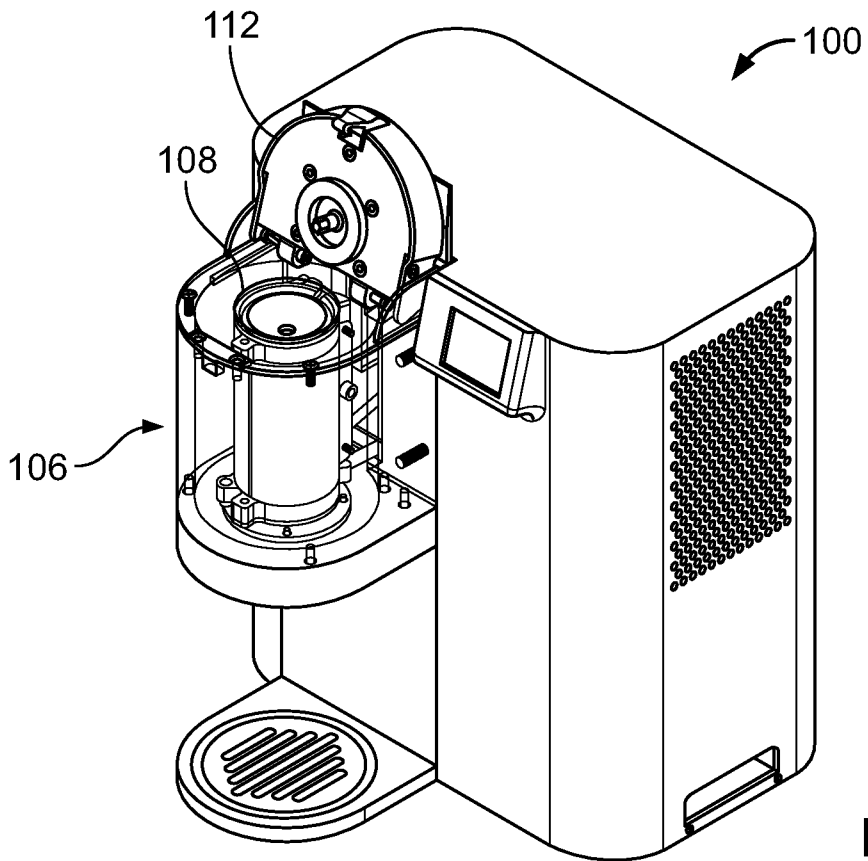

FIG. 2A

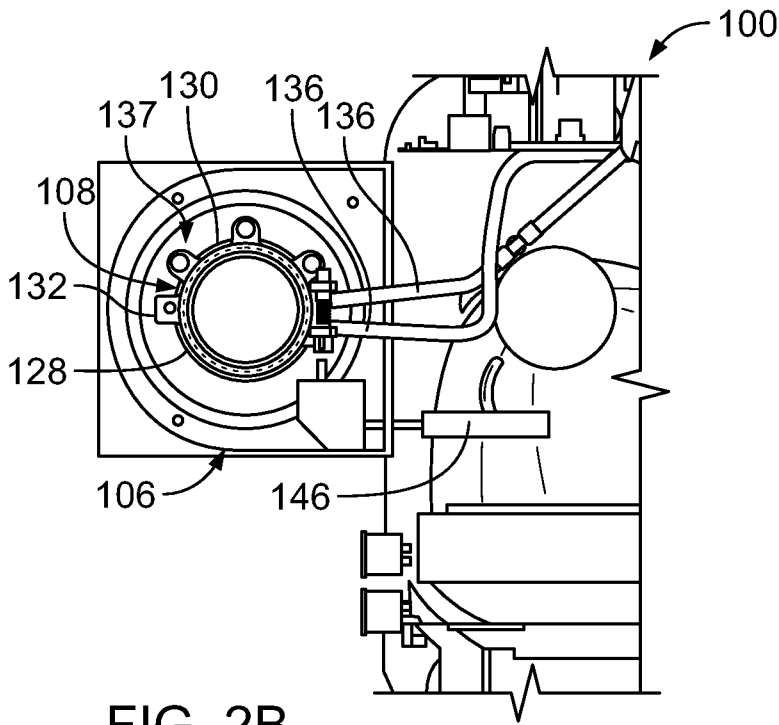

FIG. 2B

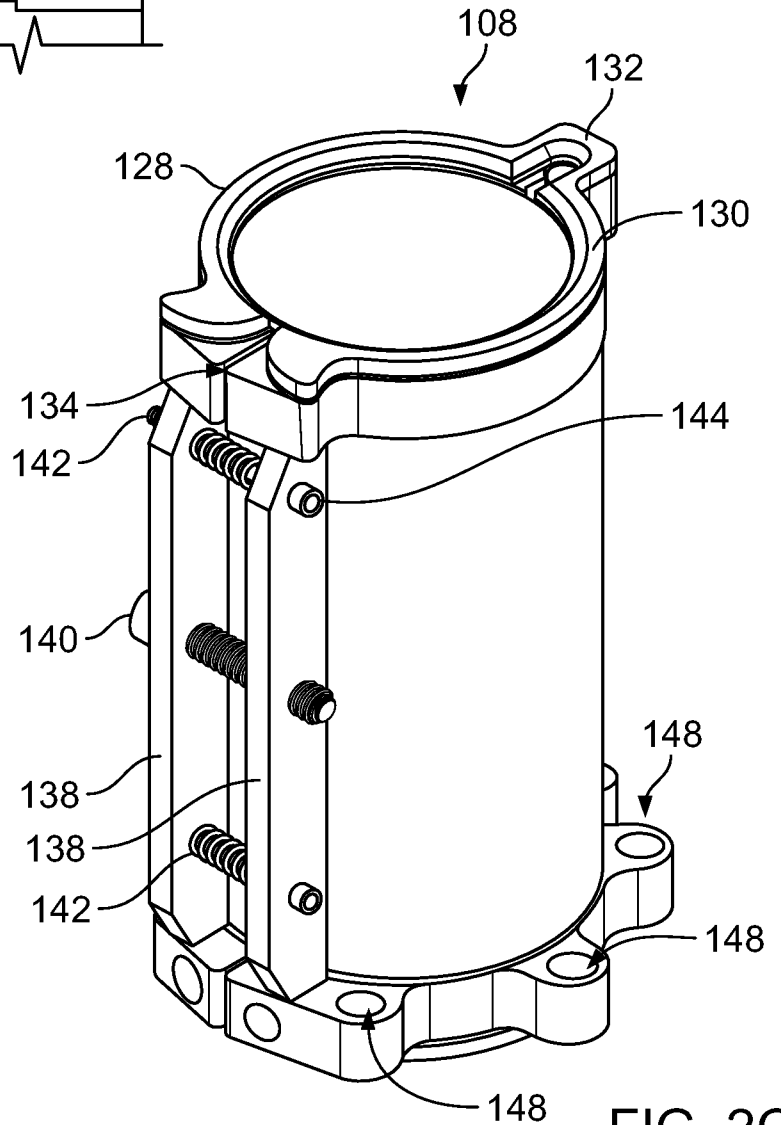

FIG. 2C

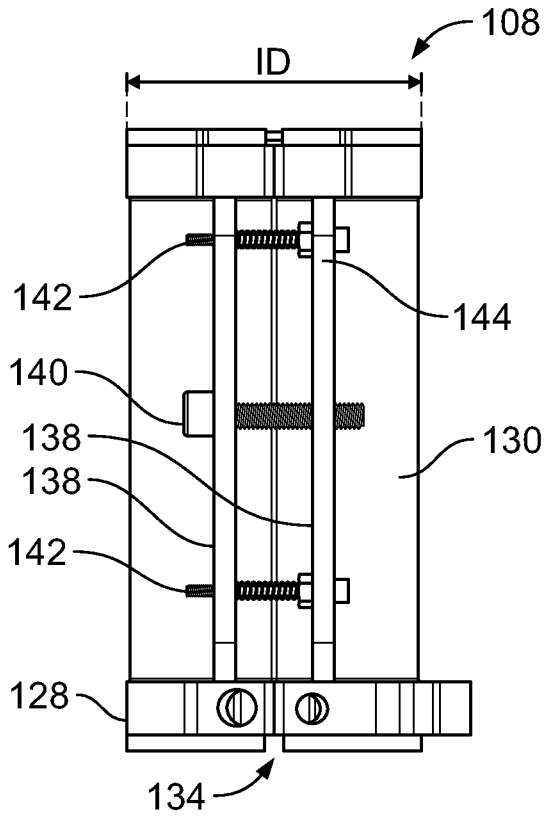

FIG. 2D

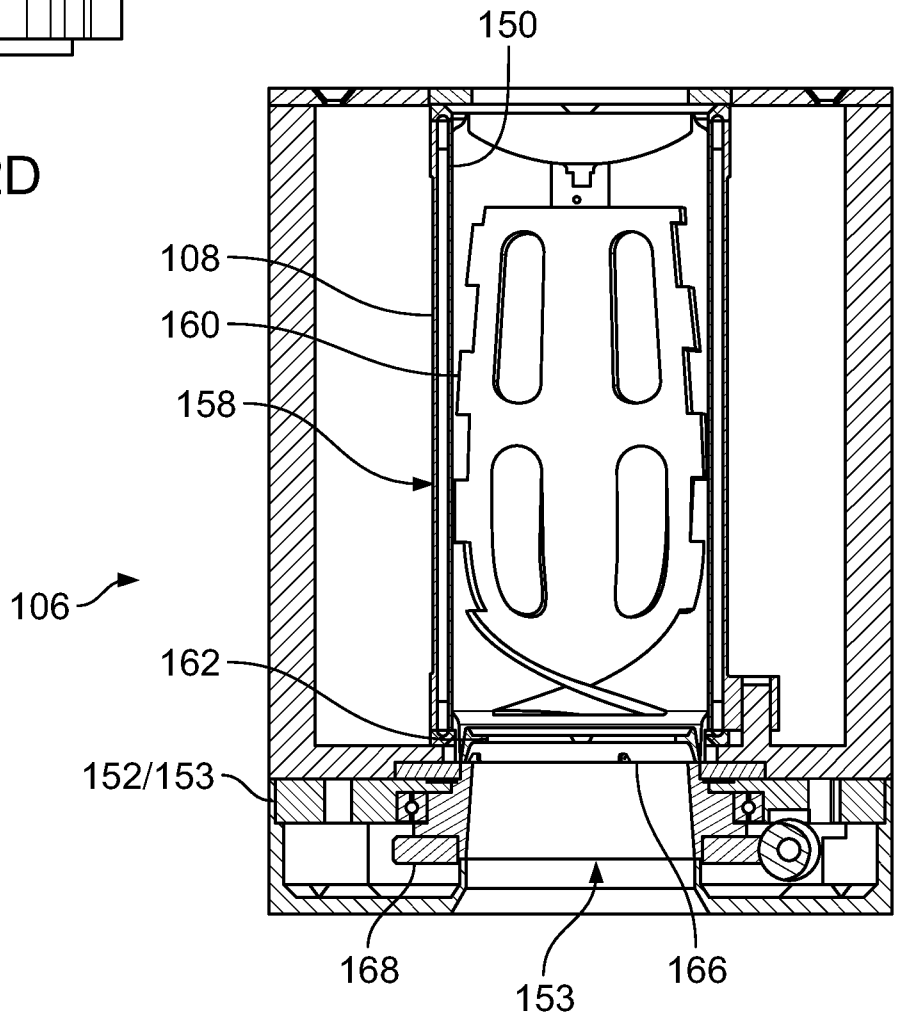

FIG. 3A

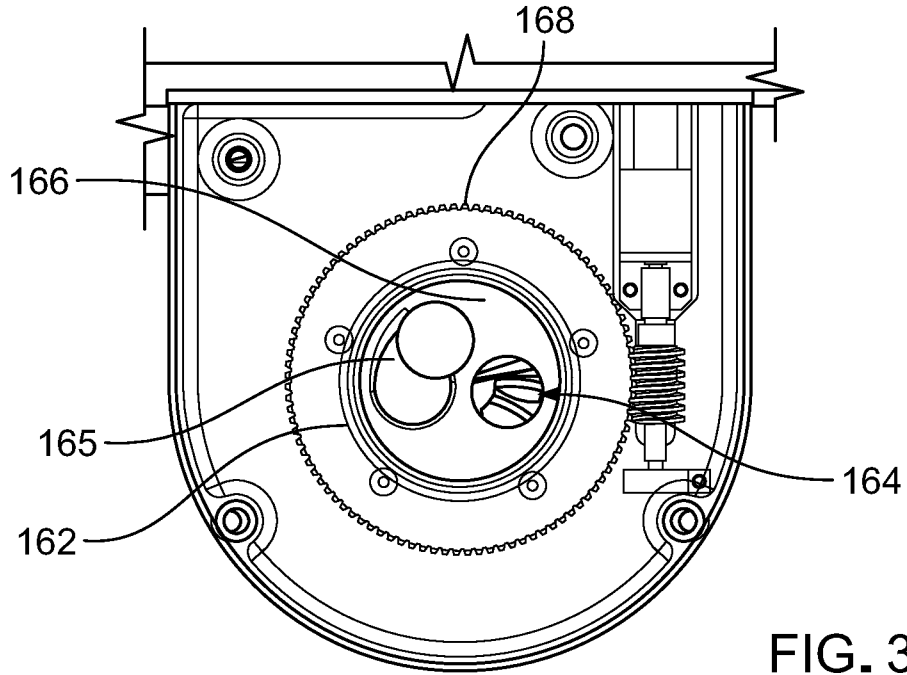

FIG. 3B

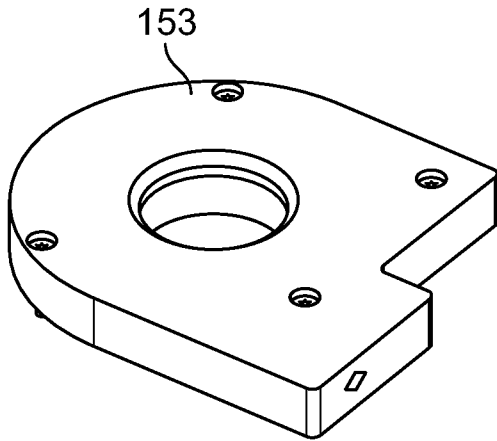

FIG. 3C

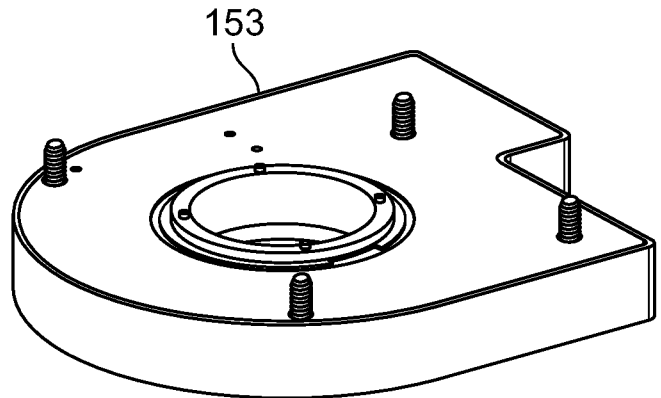

FIG. 3D

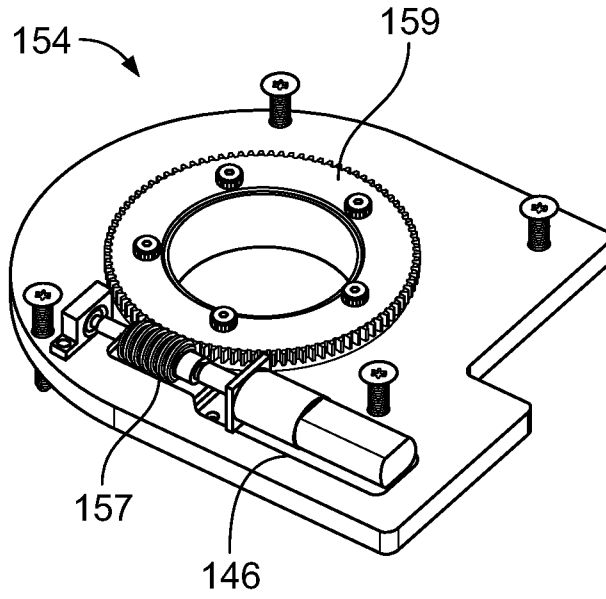

FIG. 3E

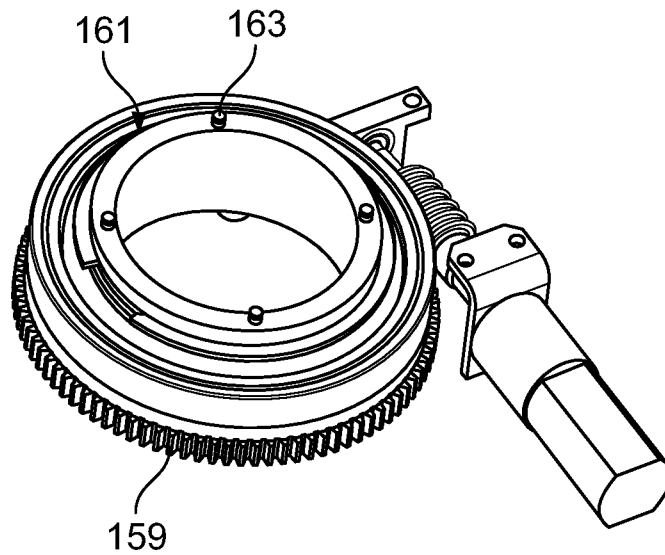

FIG. 3F

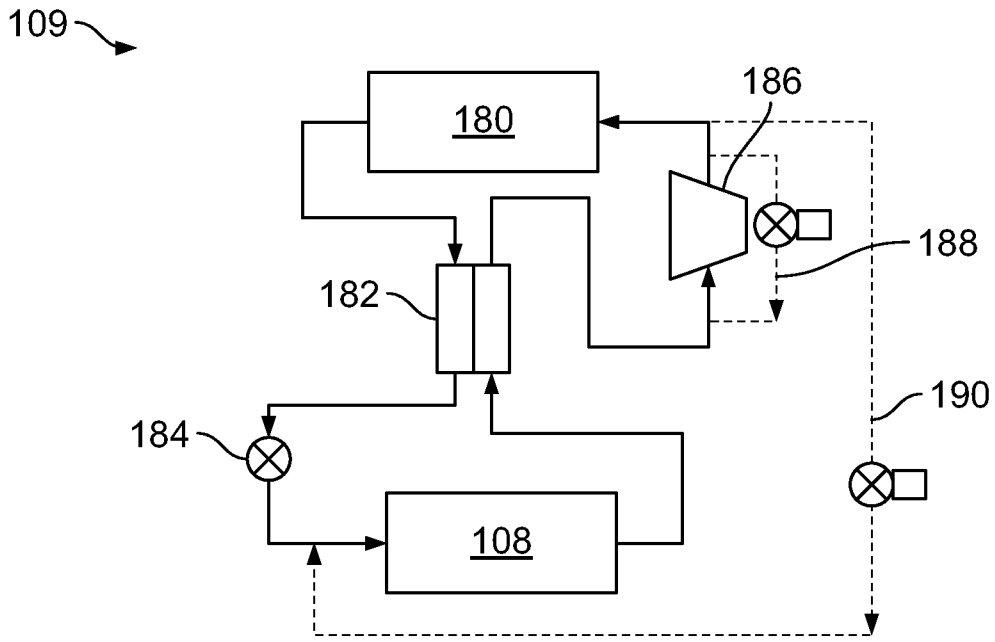

FIG. 4

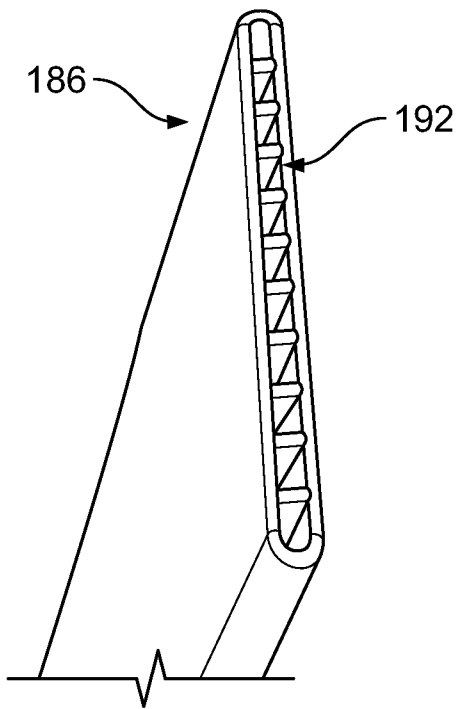

FIG. 5A

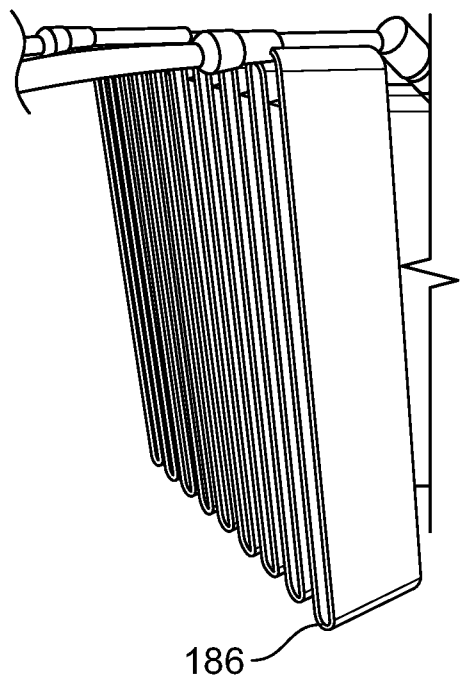

FIG. 5B

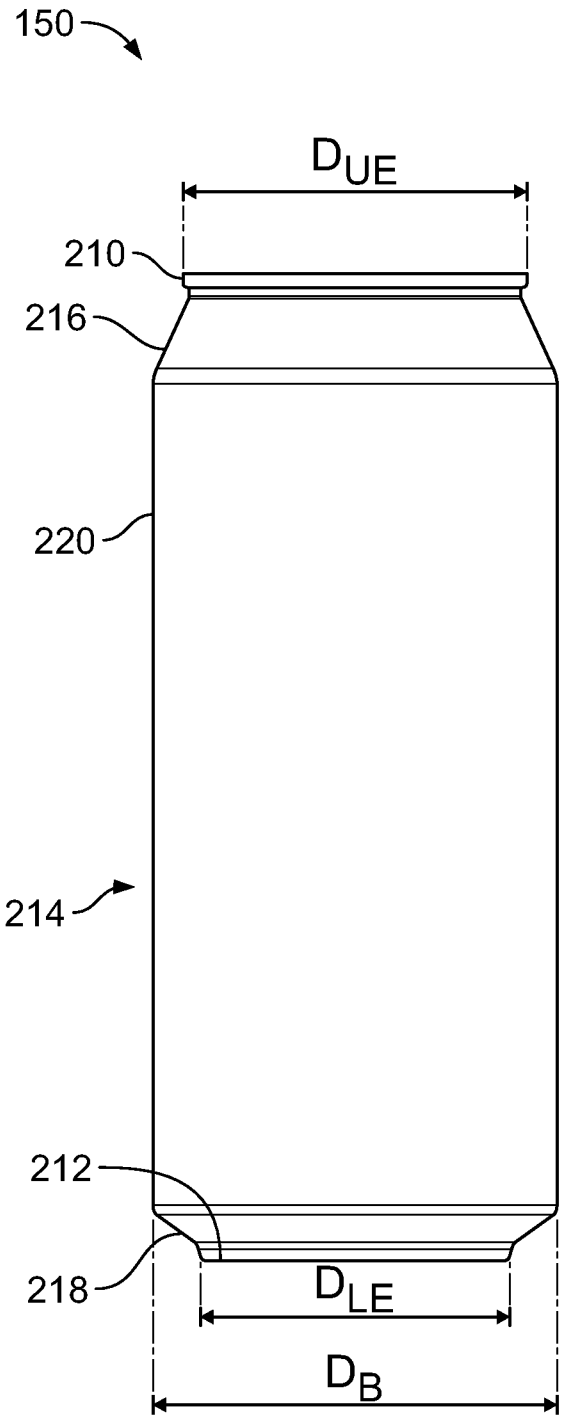

FIG. 6A

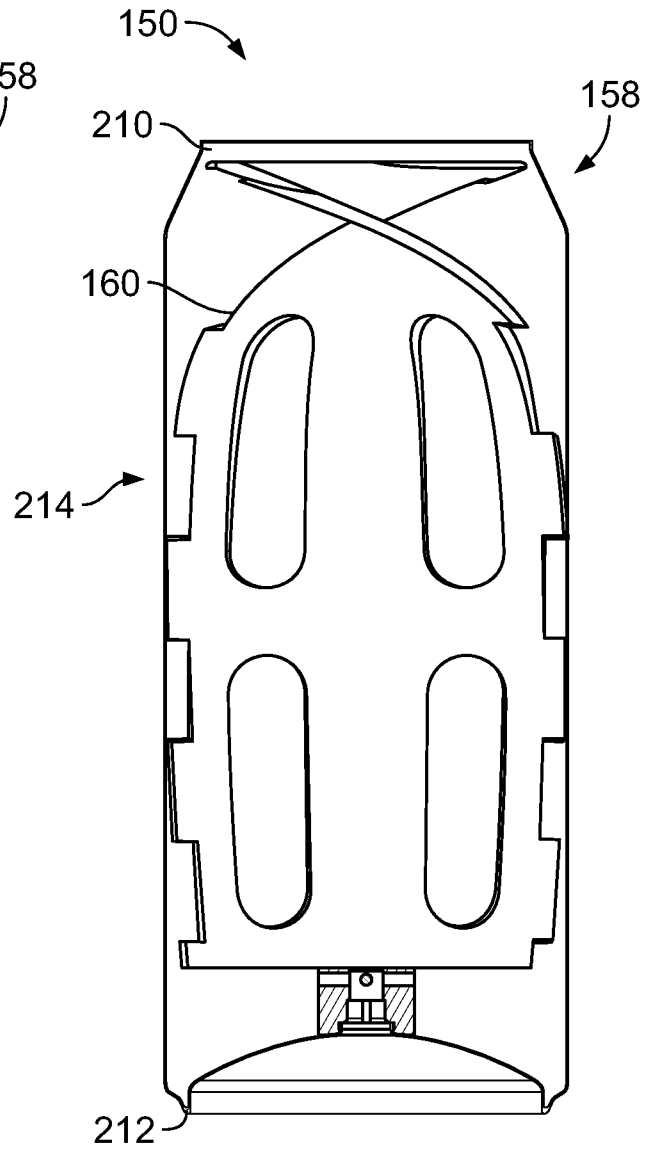

FIG. 6B

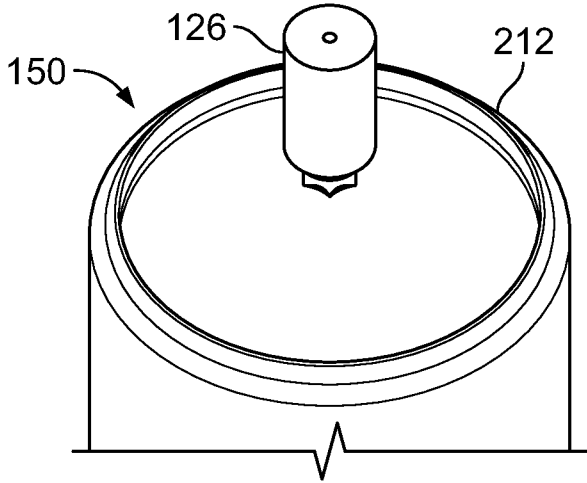

FIG. 7A

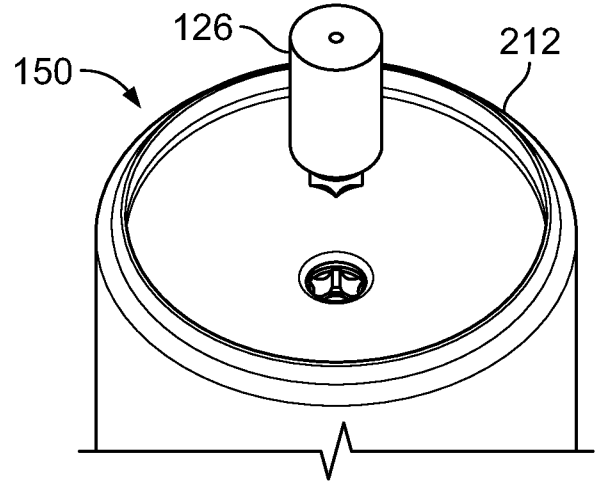

FIG. 7B

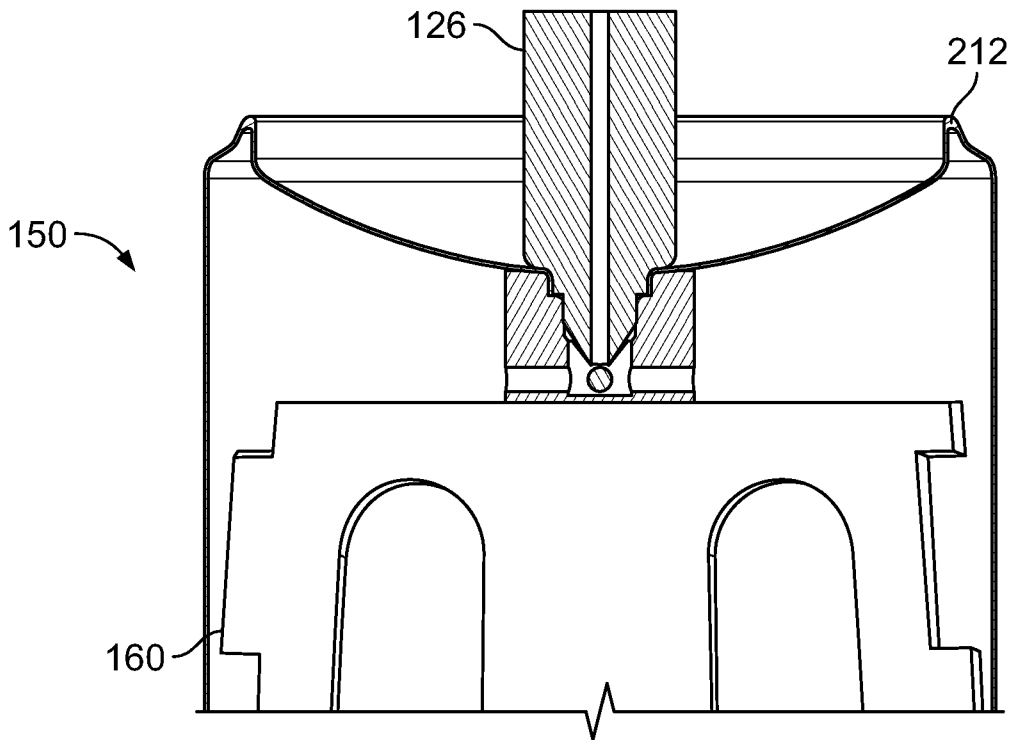

FIG. 7C

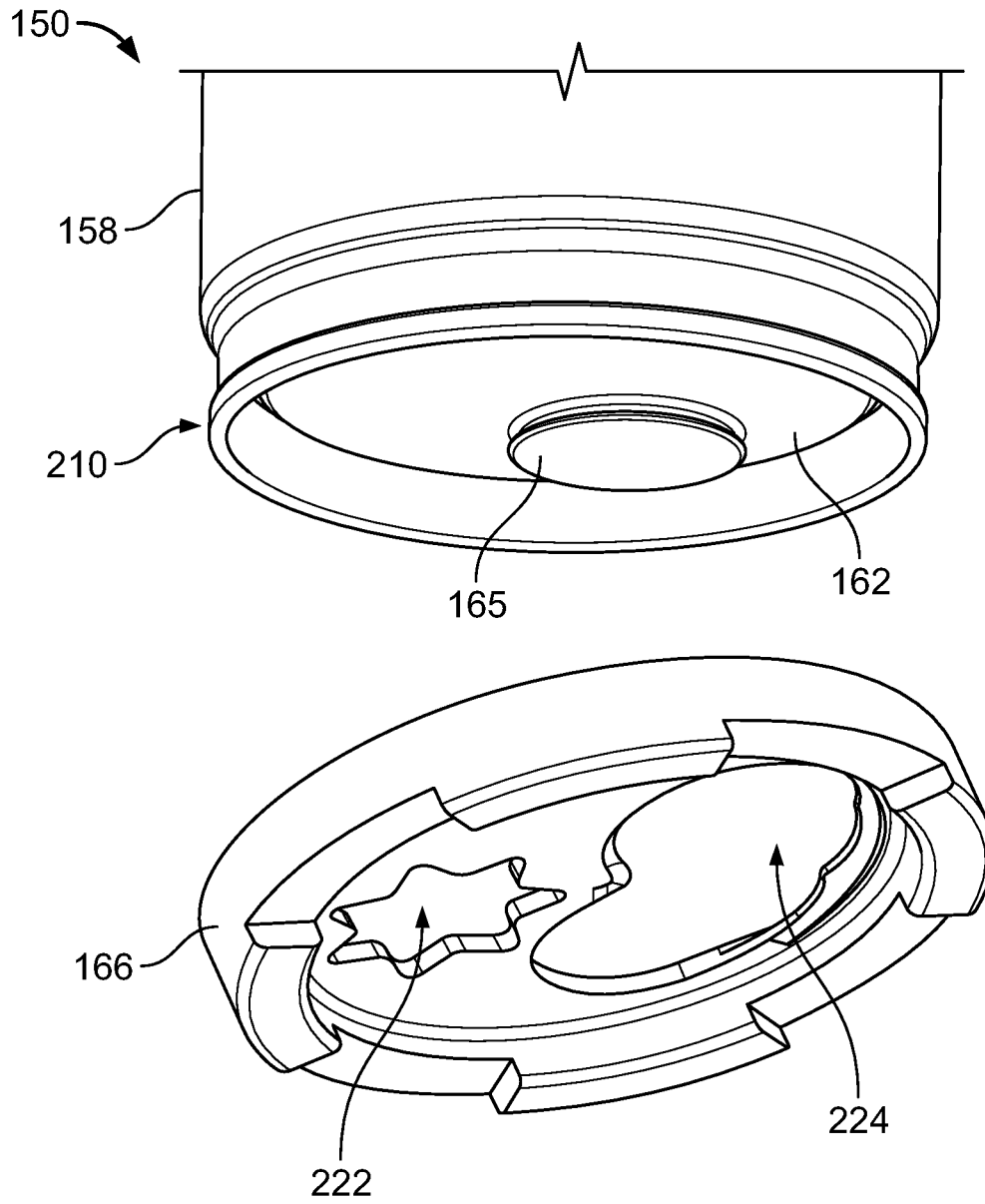

FIG. 8

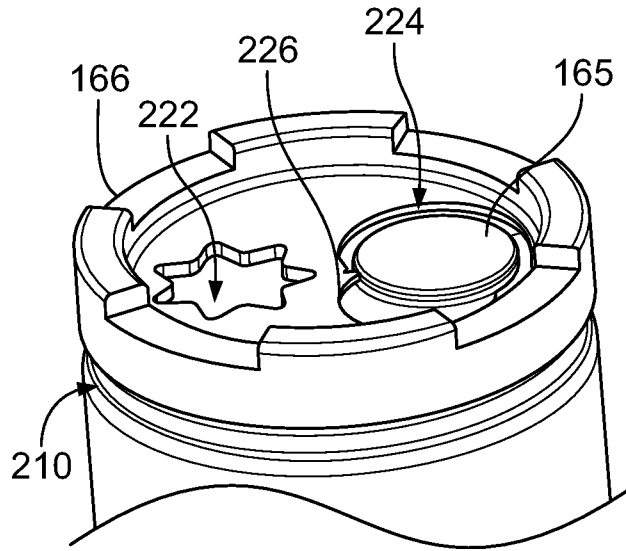

FIG. 9A

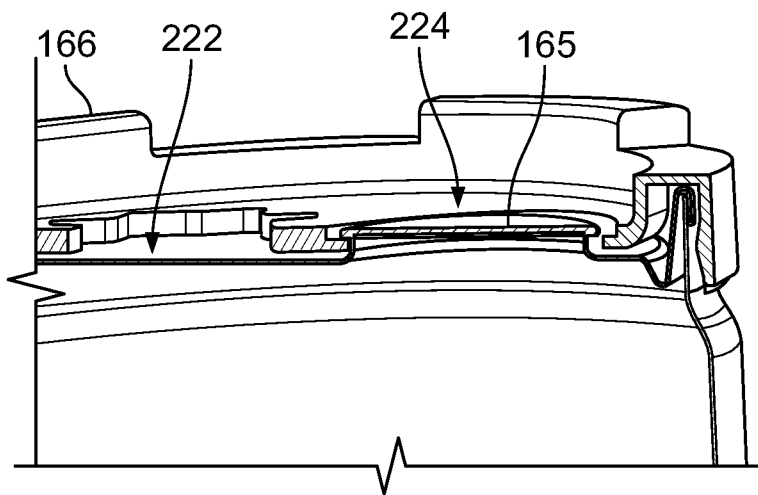

FIG. 9B

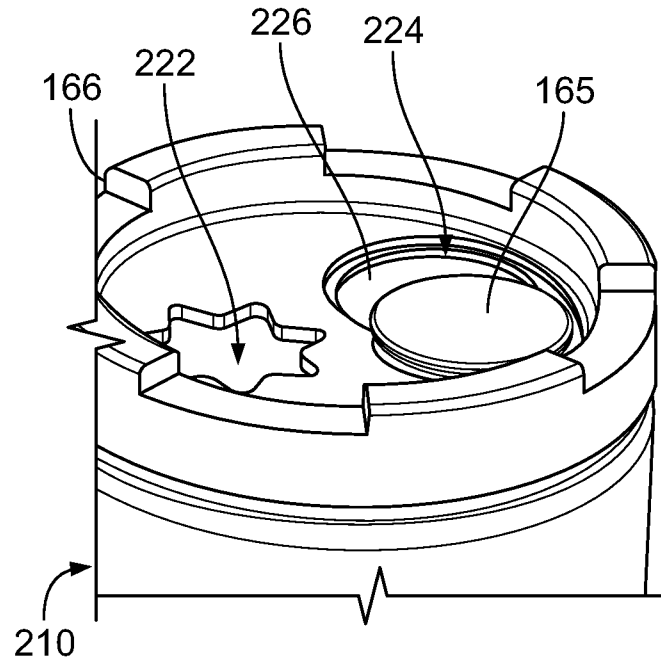

FIG. 9C

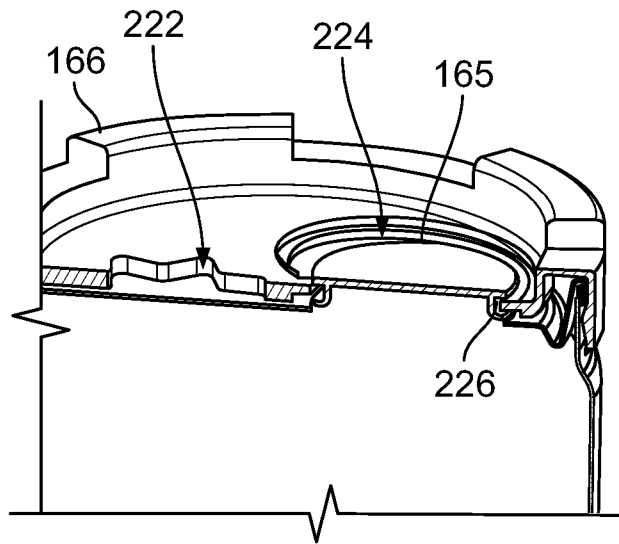

FIG. 9D

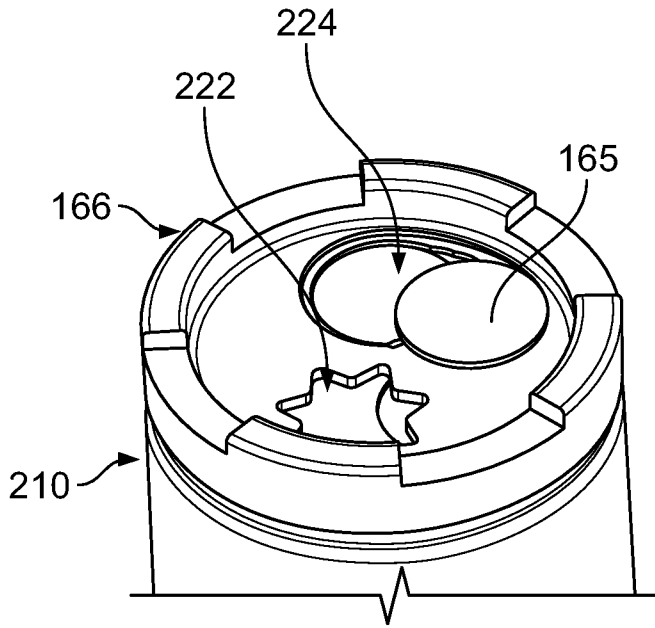

FIG. 9E

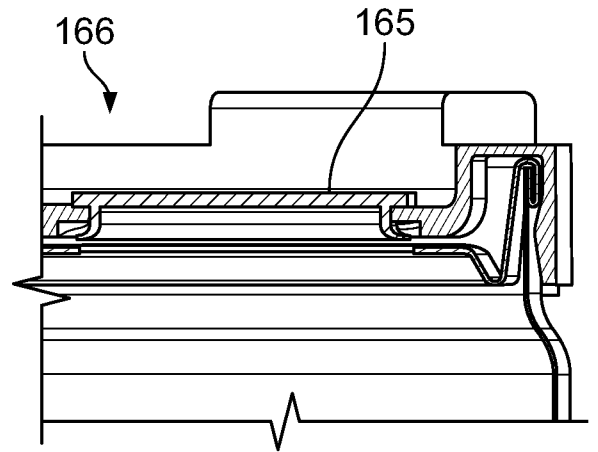

FIG. 9F

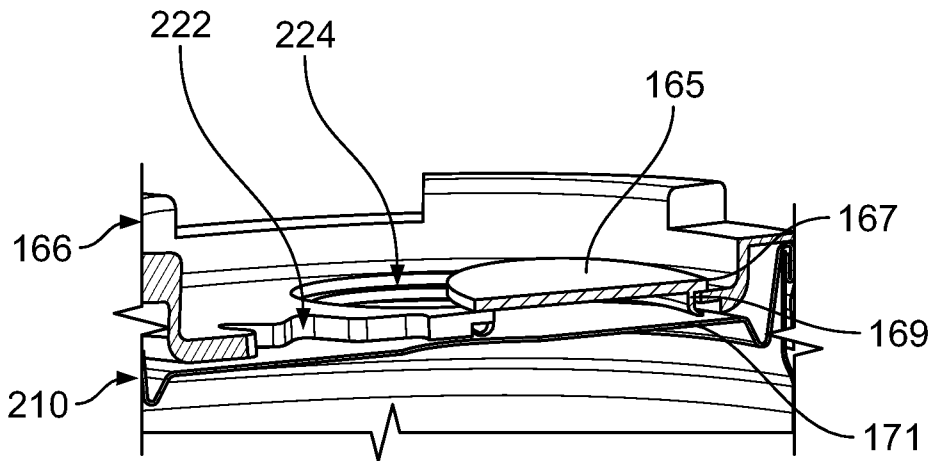

FIG. 9G

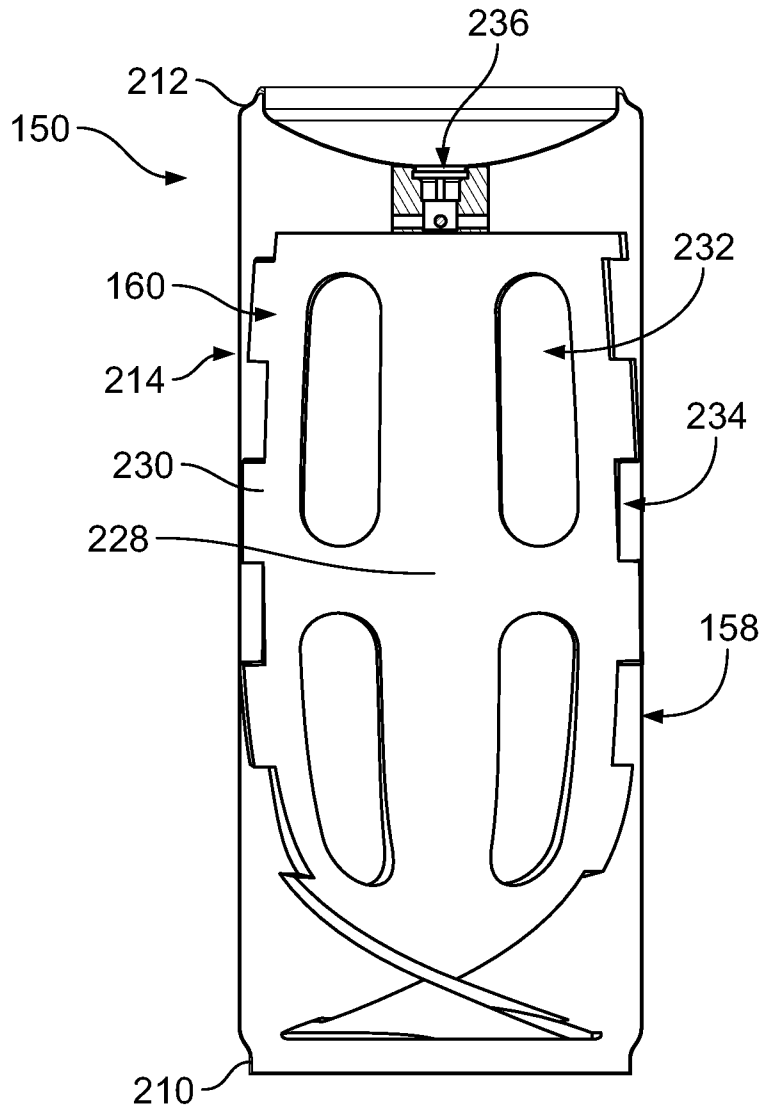

FIG. 10

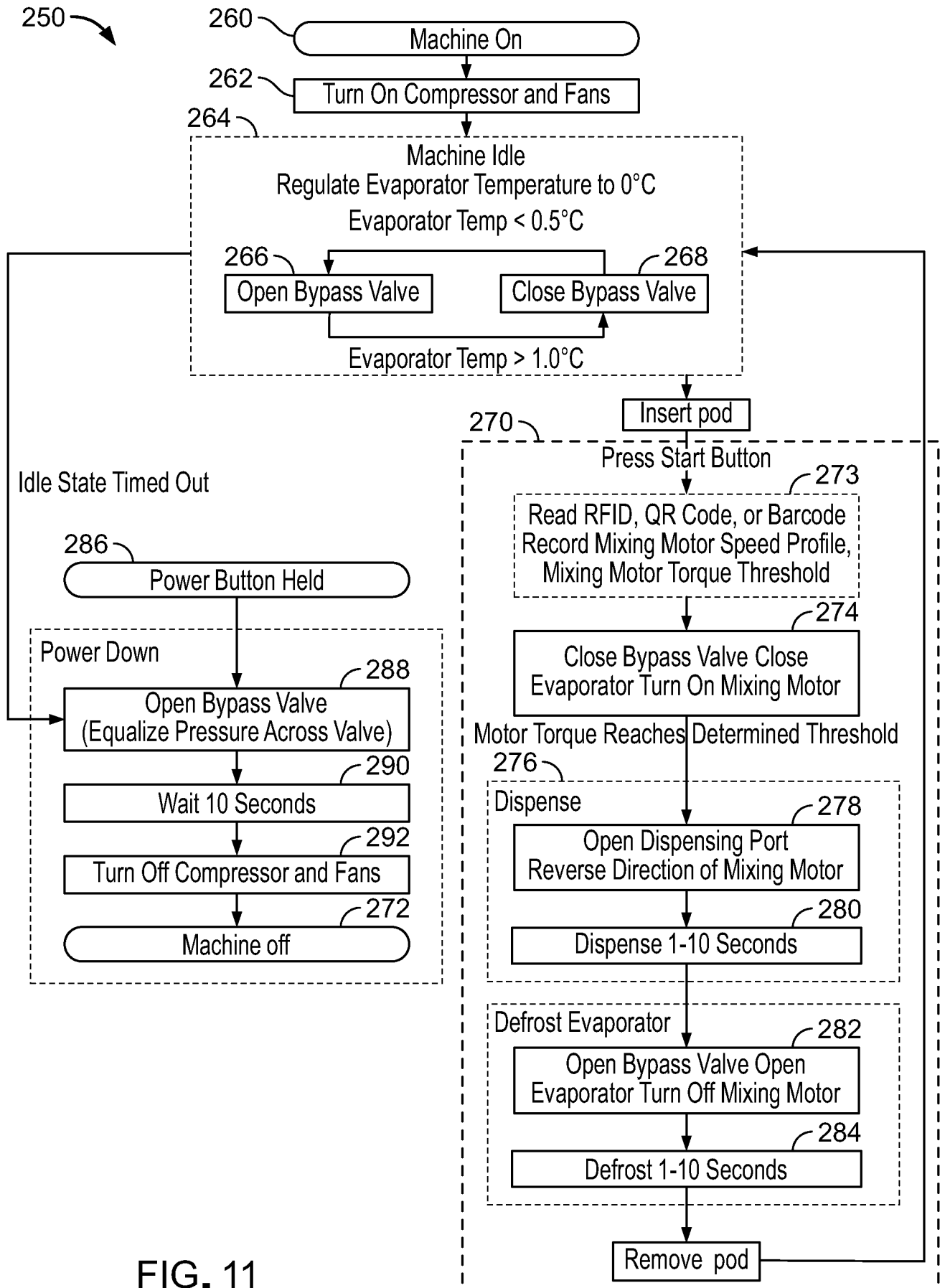

FIG. 11

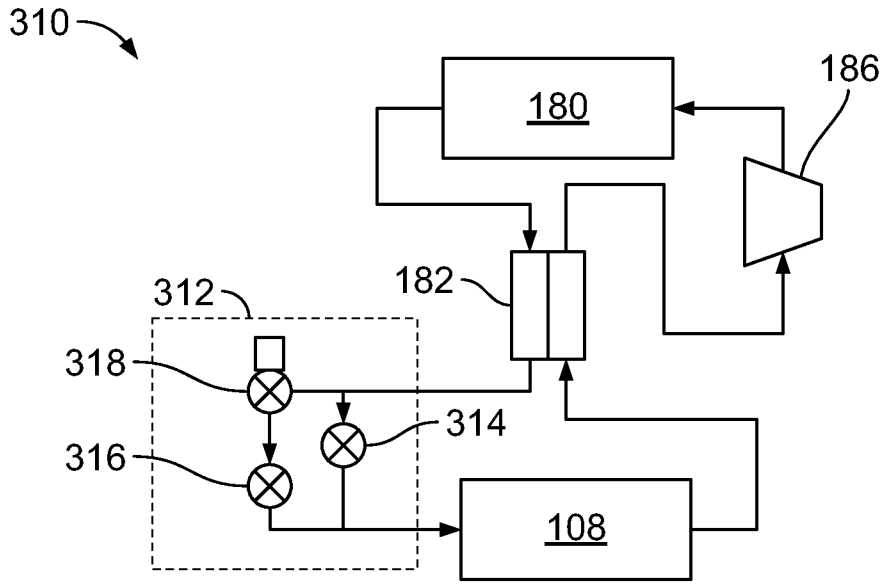

FIG. 12

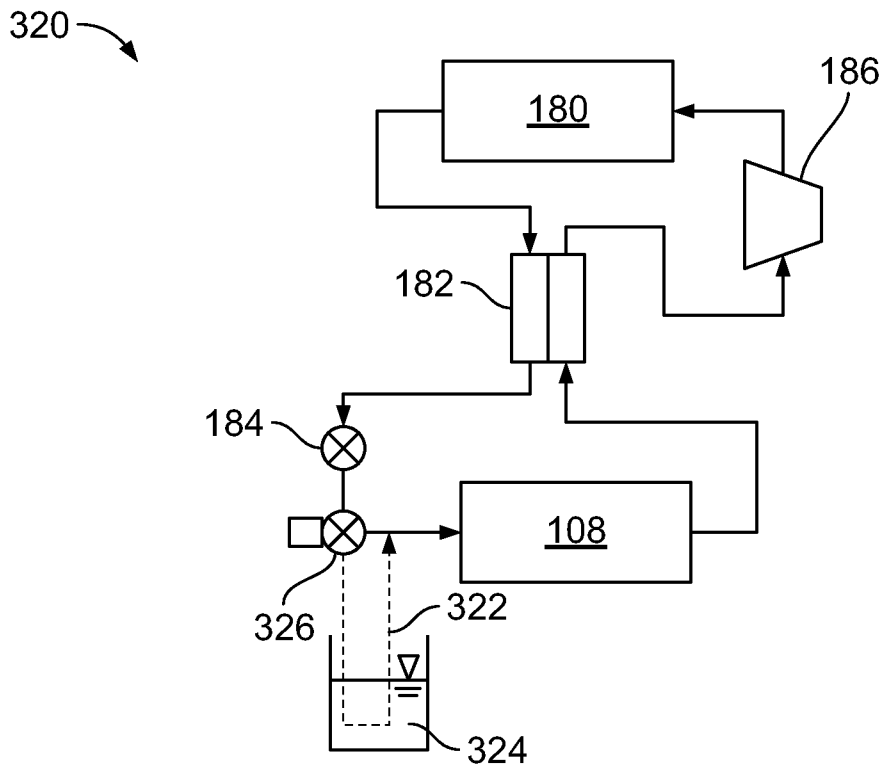

FIG. 13

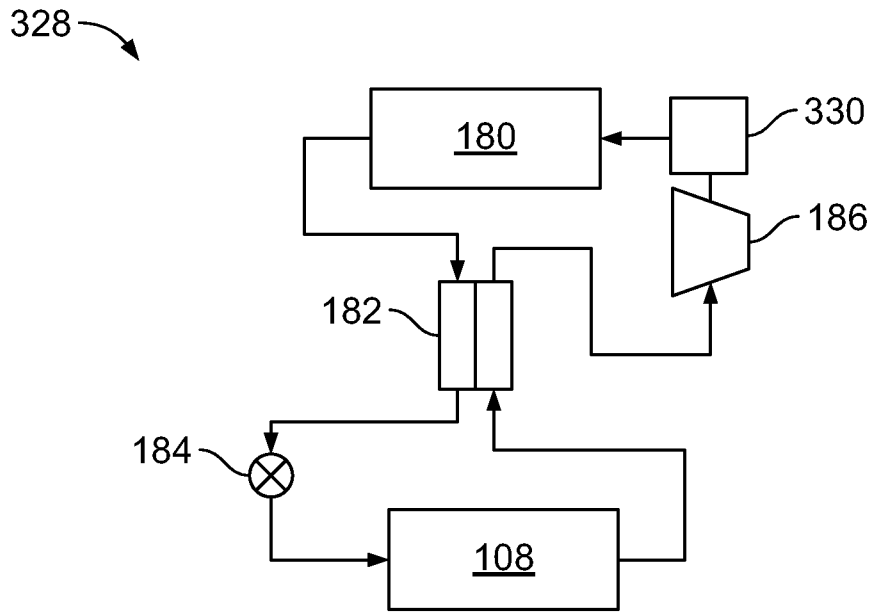

FIG. 14

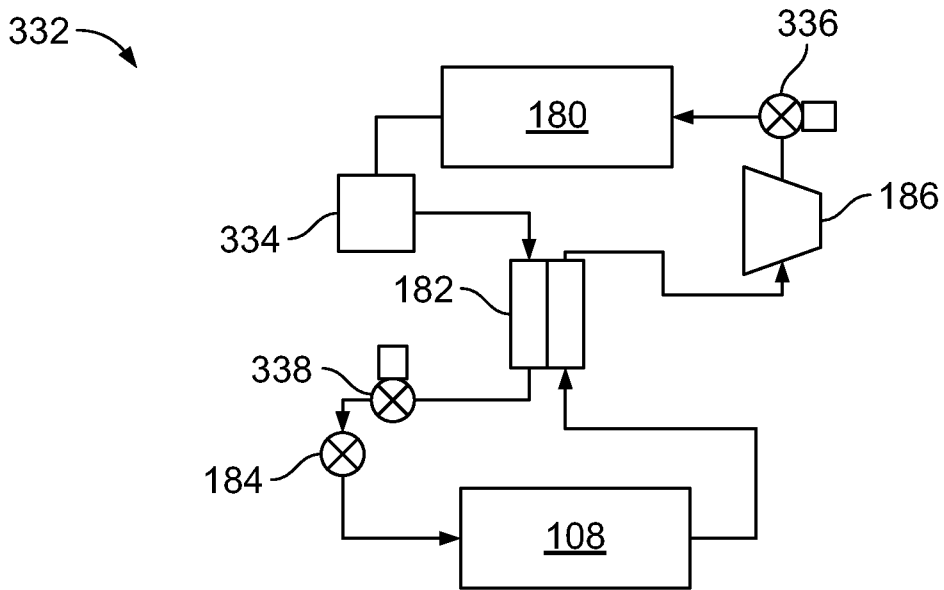

FIG. 15

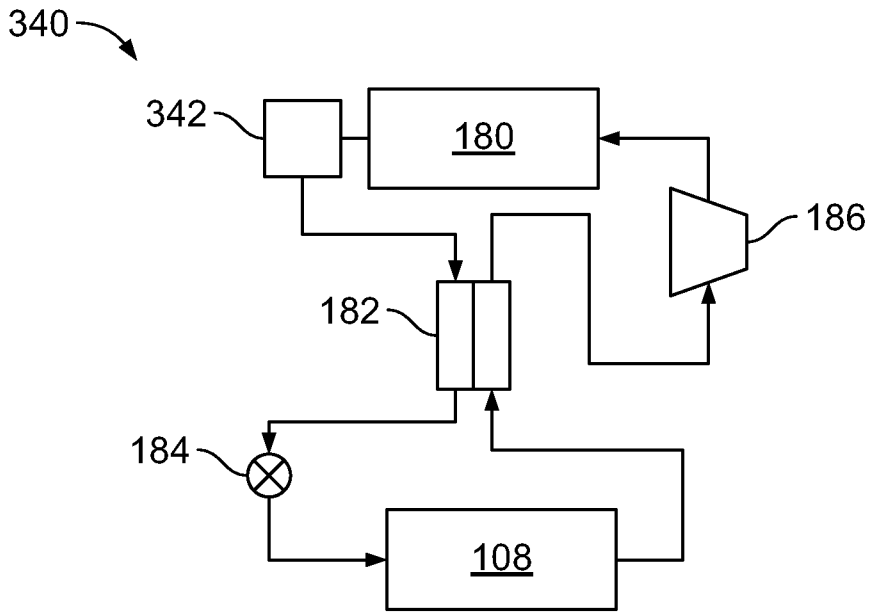

FIG. 16

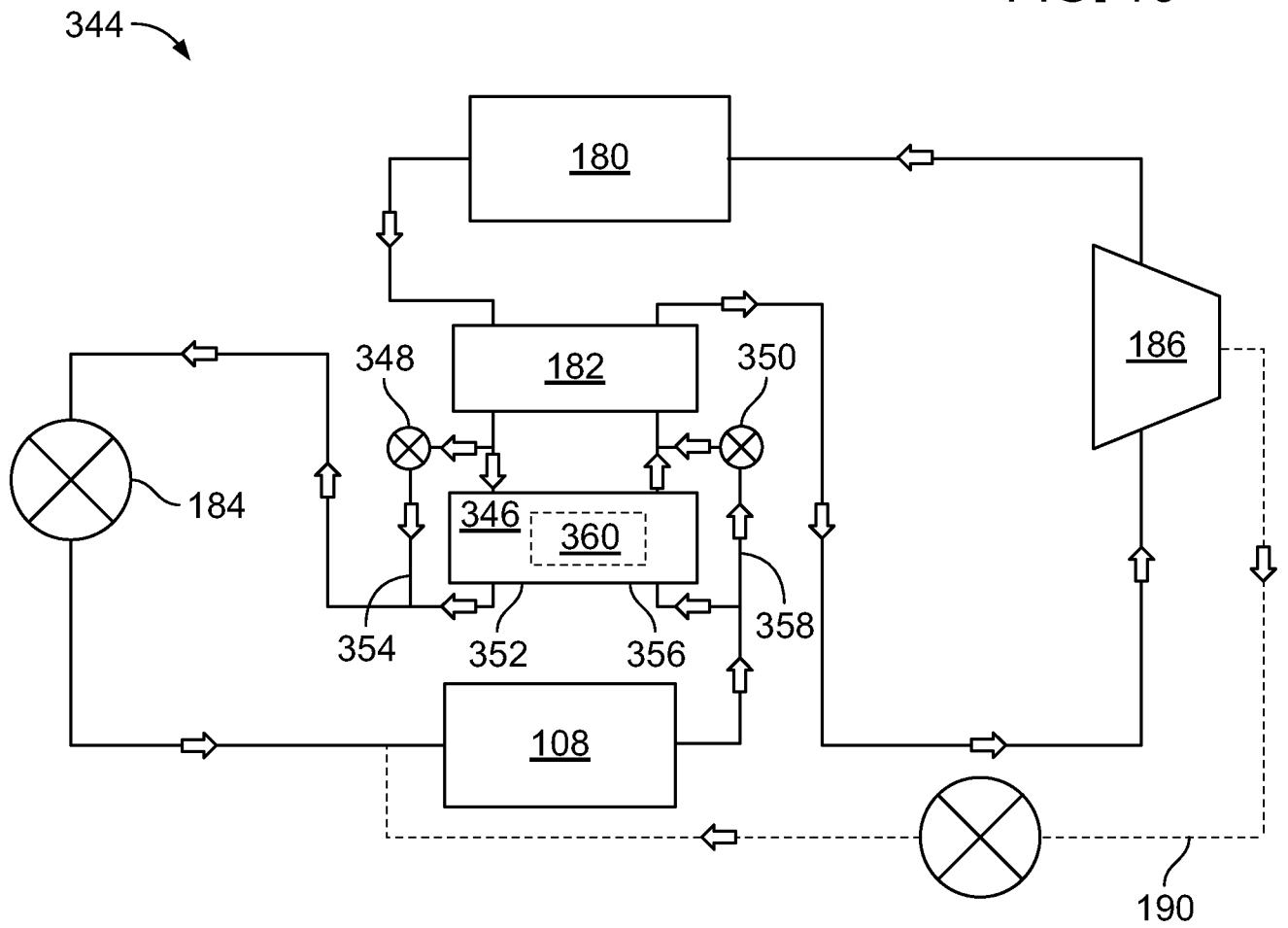

FIG. 17

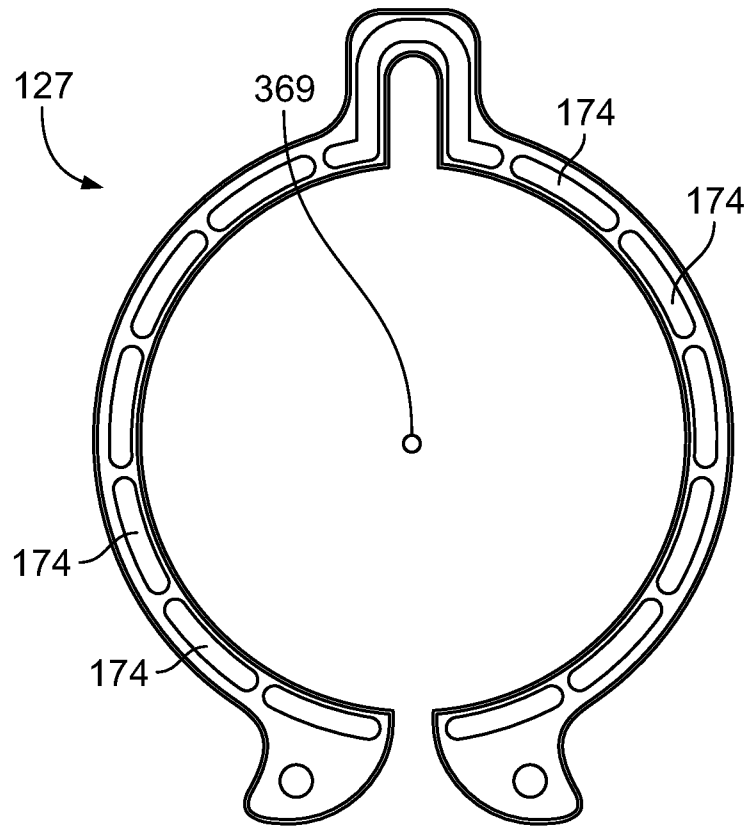

FIG. 18A

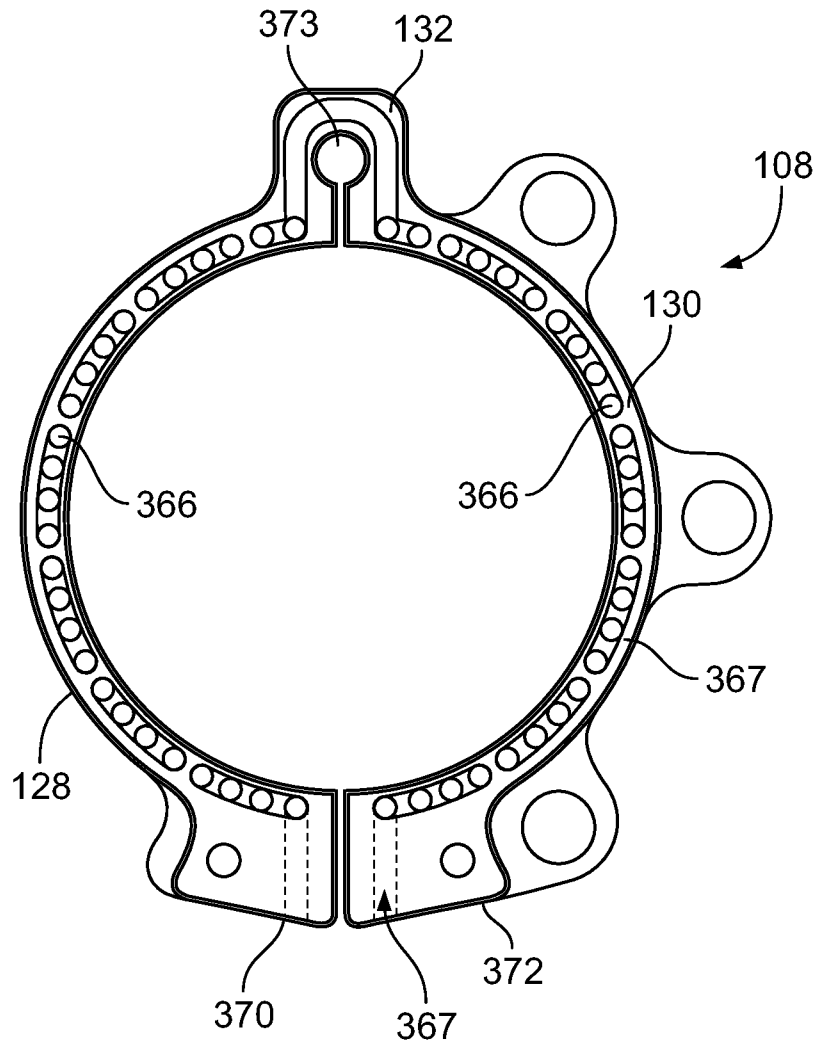

FIG. 18B

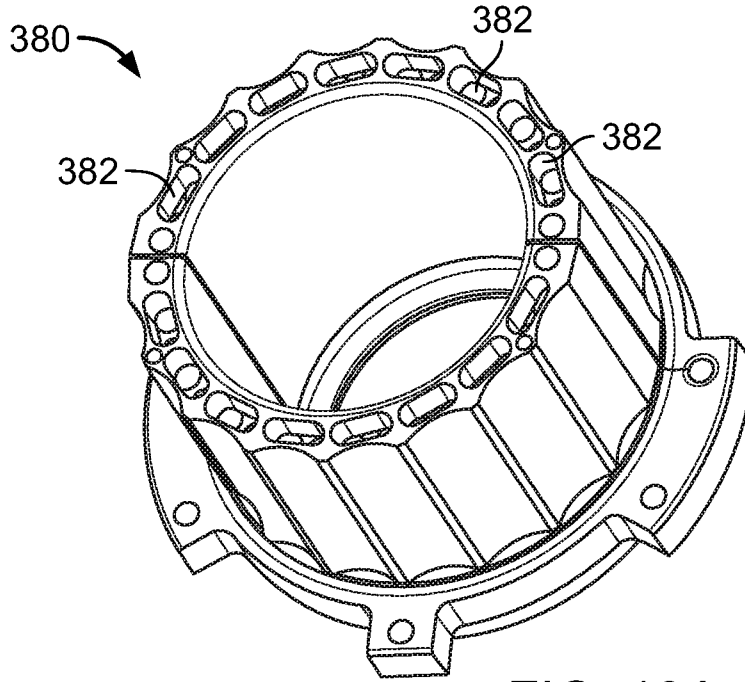

FIG. 19A

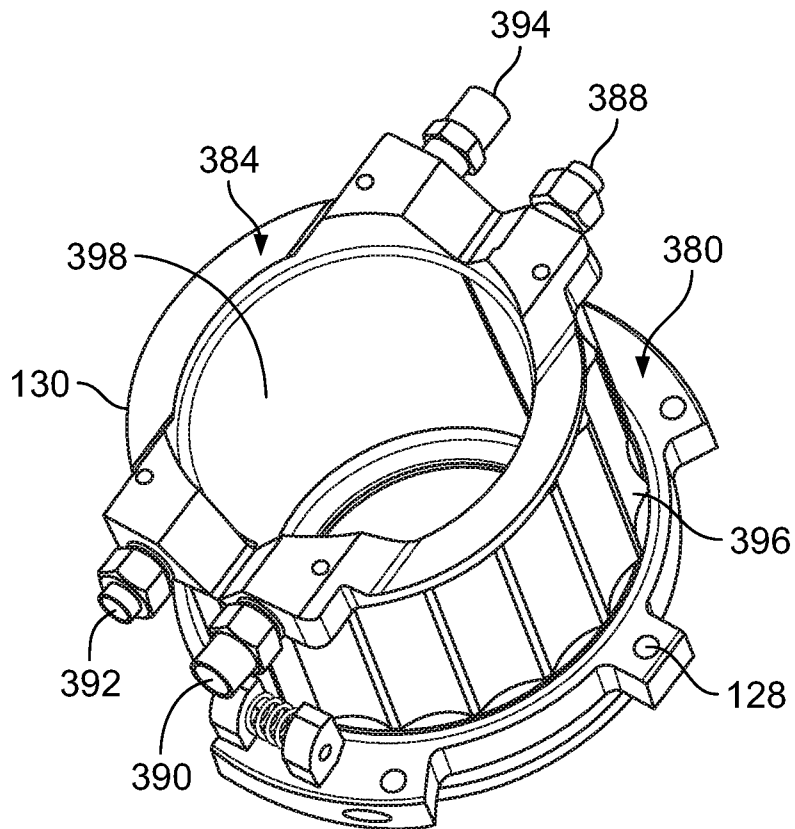

FIG. 19B

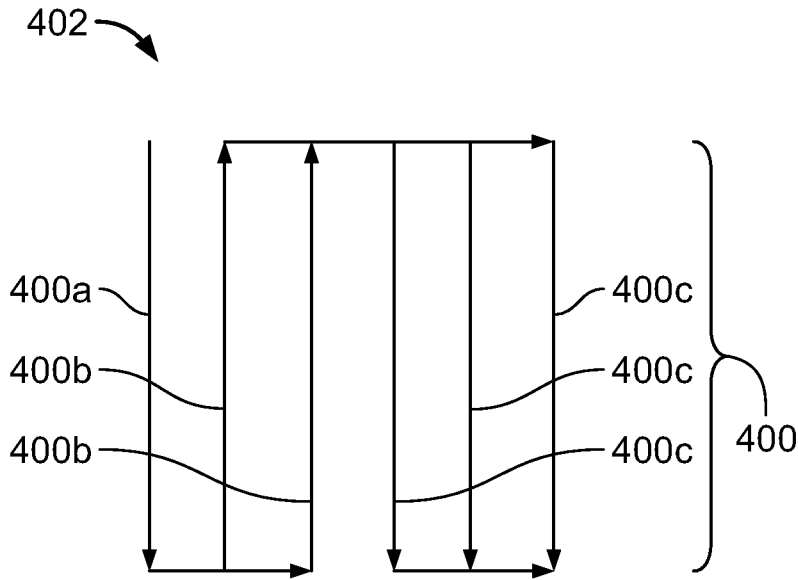

FIG. 20A

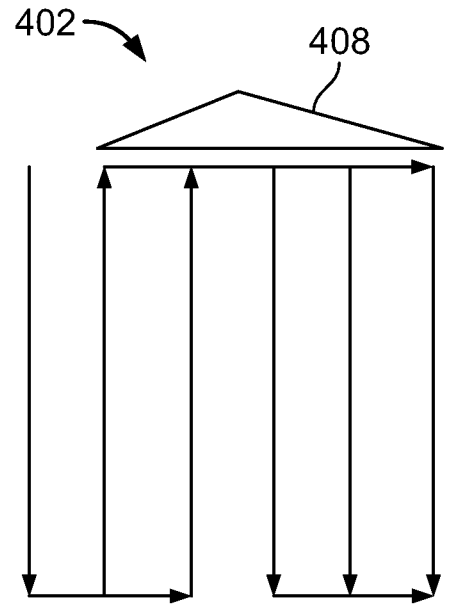

FIG. 20B

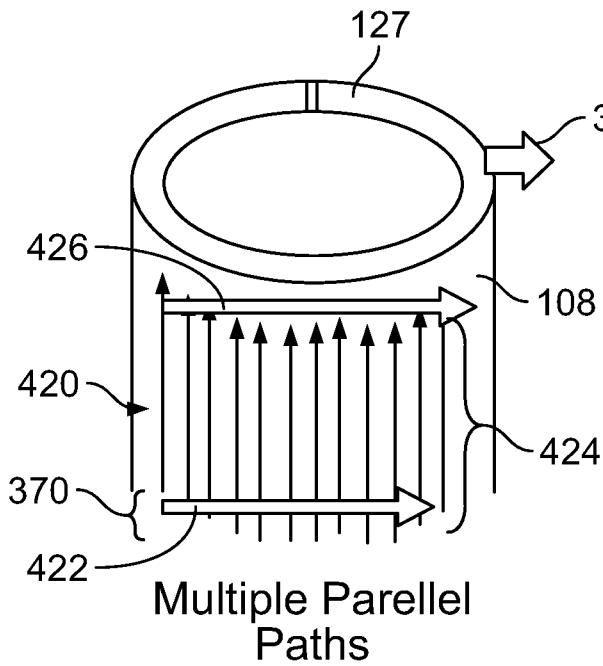

FIG. 20C

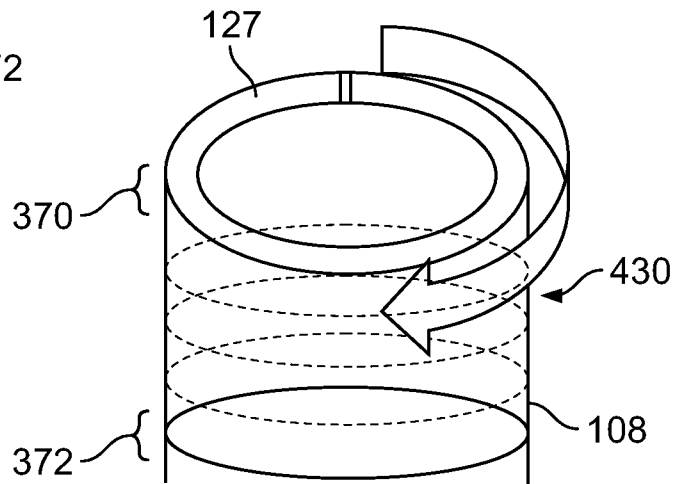

FIG. 20D

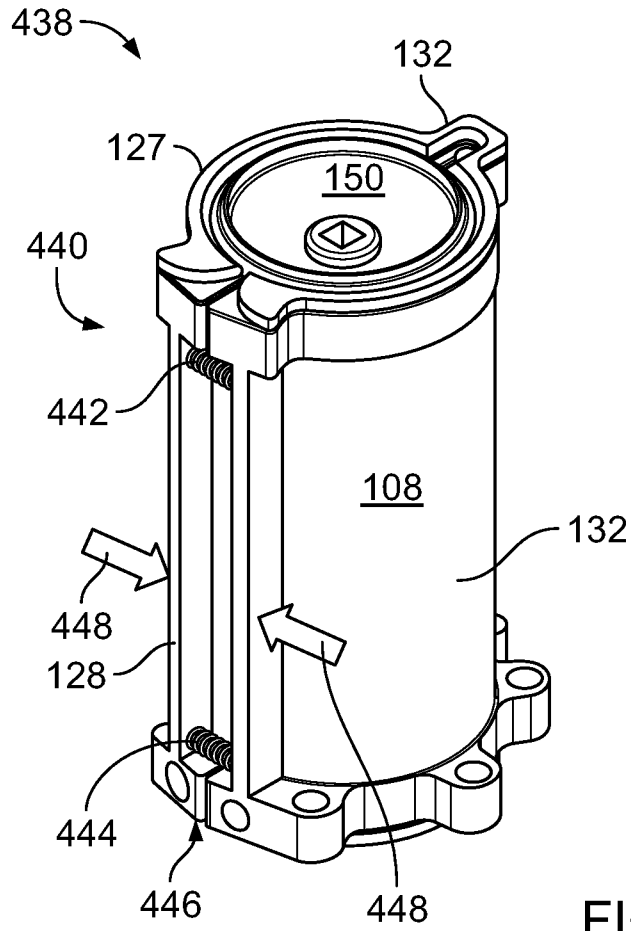

FIG. 21A

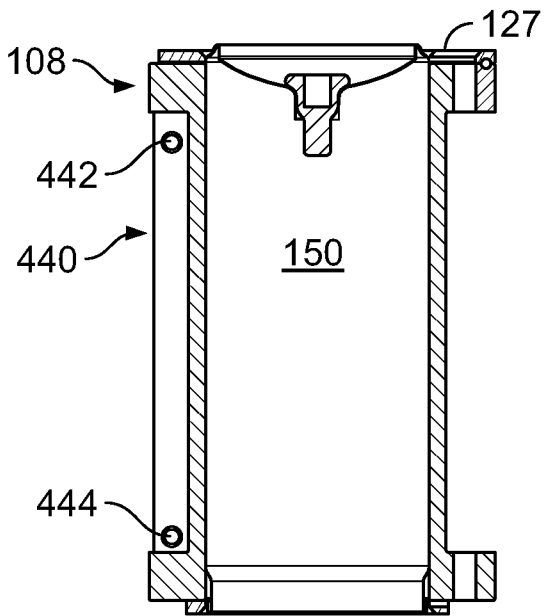

FIG. 21B

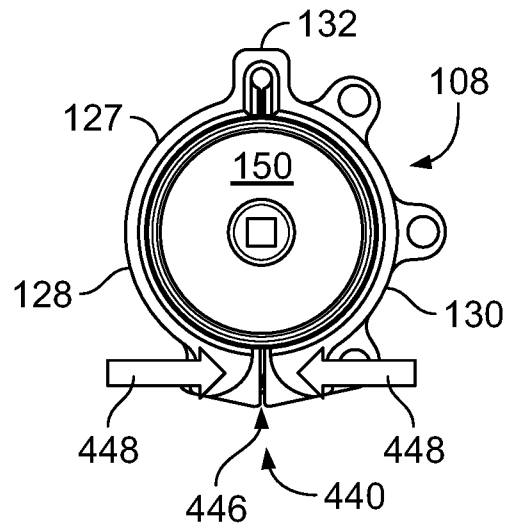

FIG. 21C

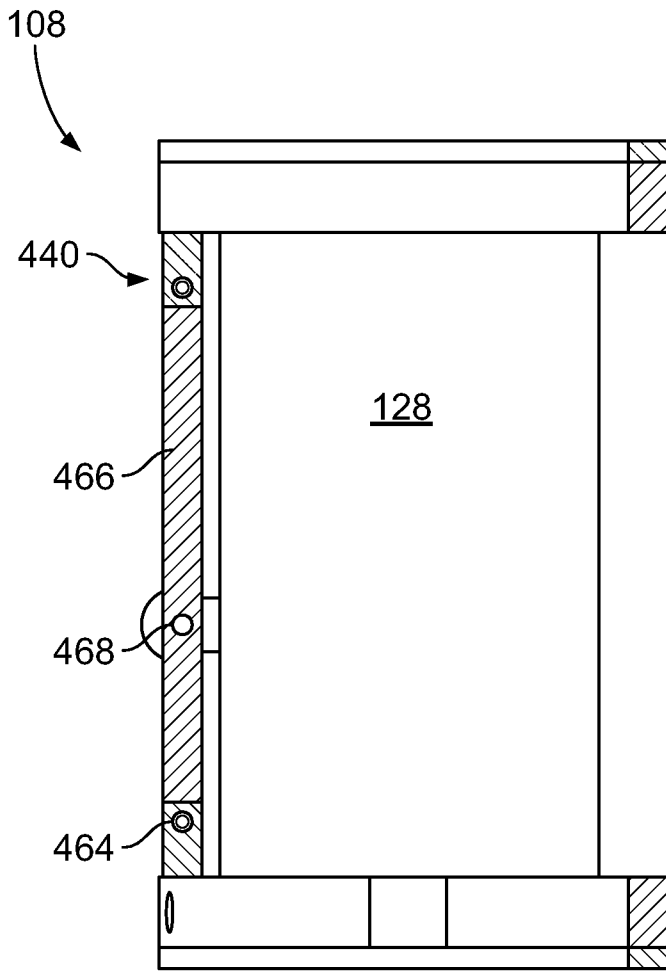

FIG. 22A

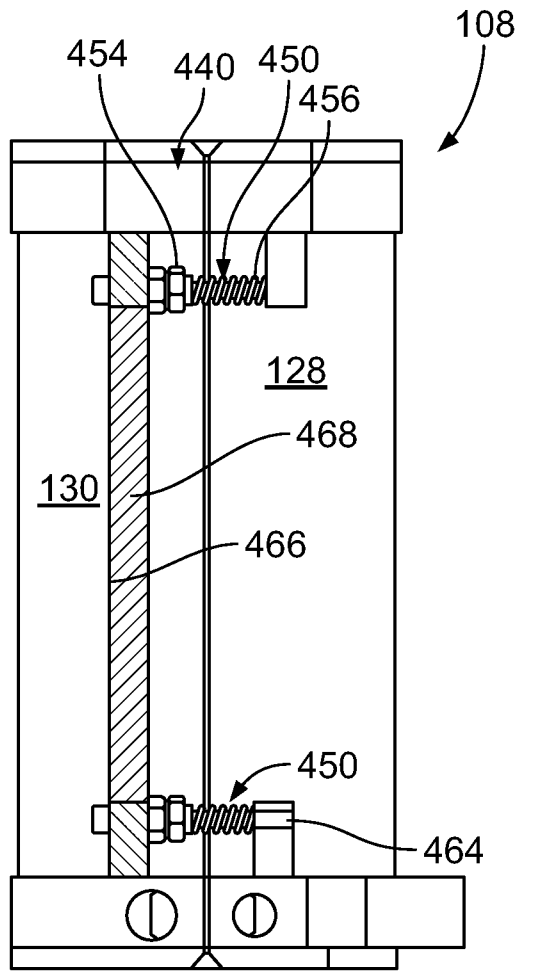

FIG. 22B

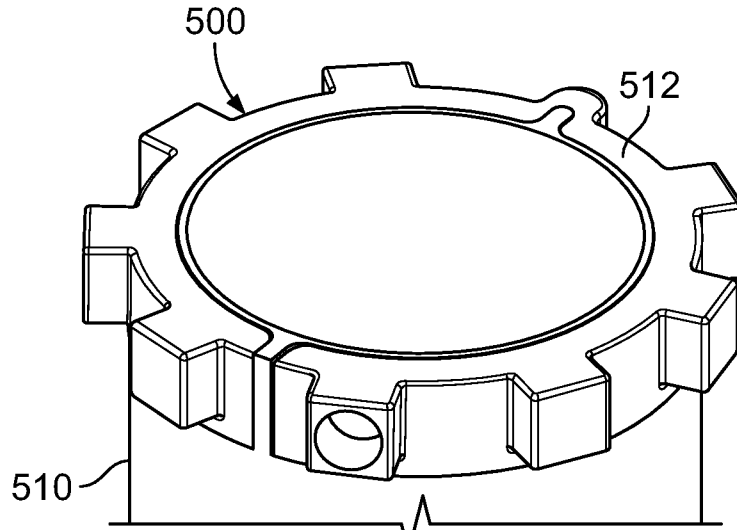

FIG. 23A

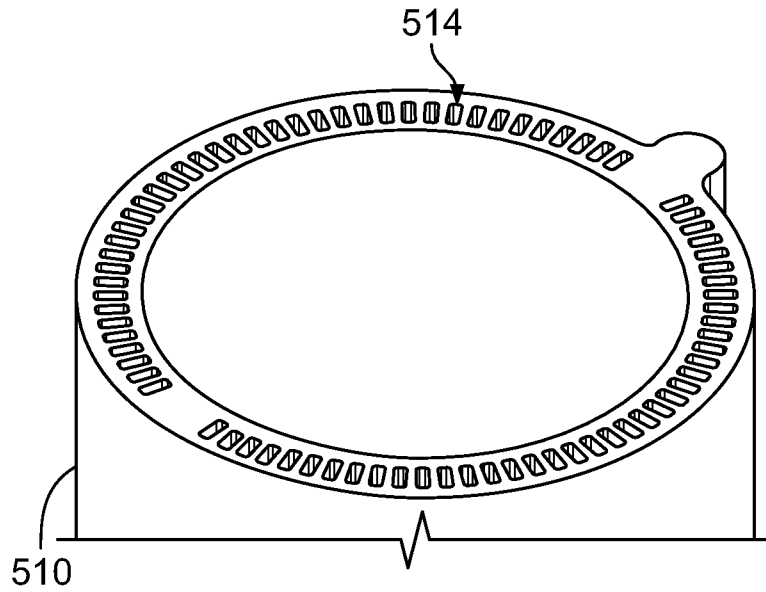

FIG. 23B

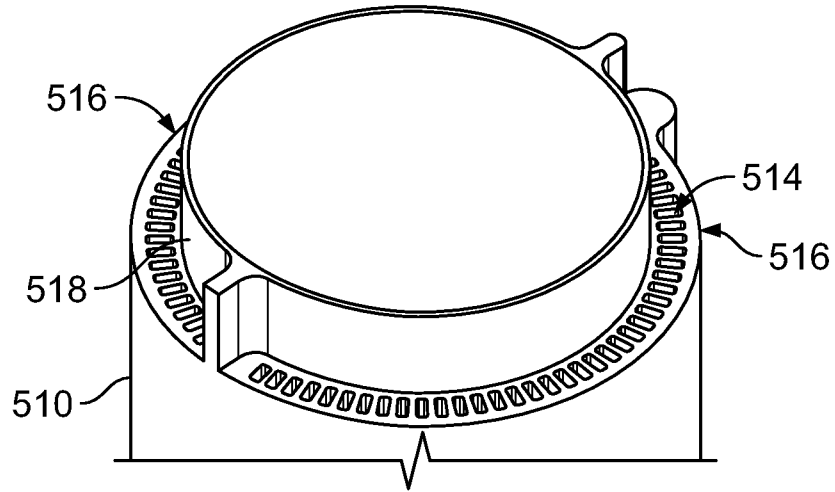

FIG. 23C

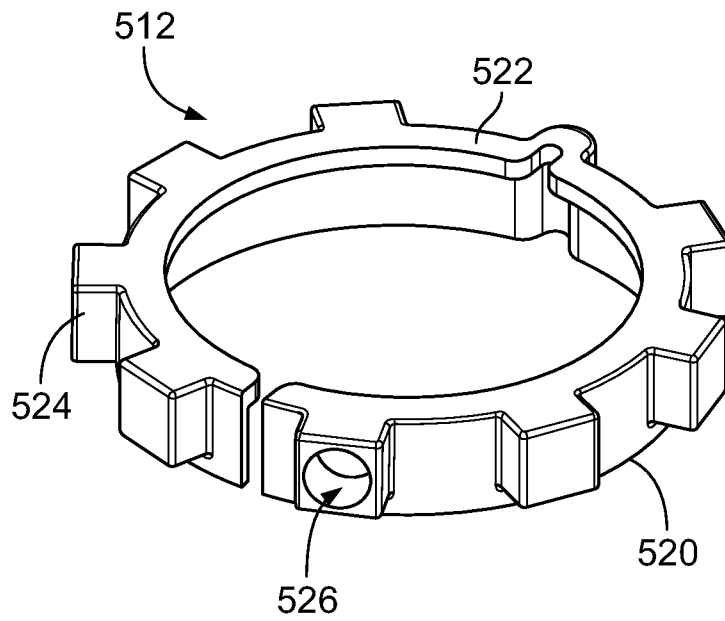

FIG. 23D

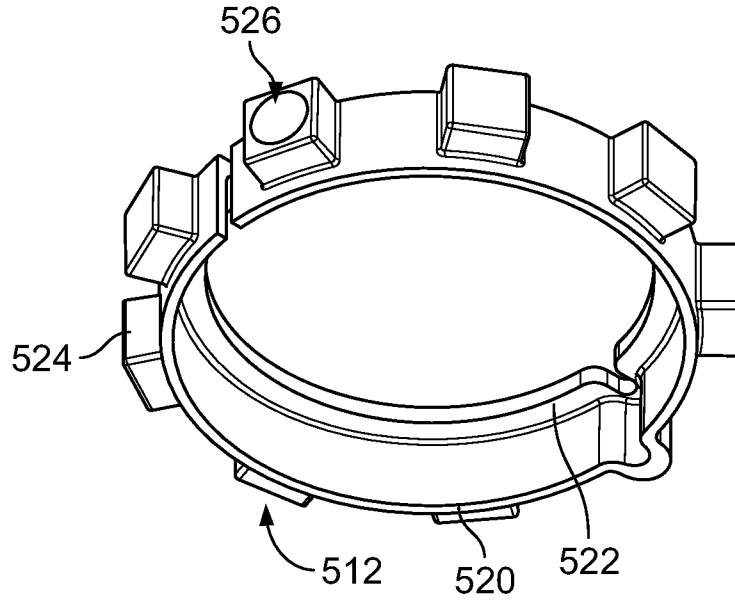

FIG. 23E

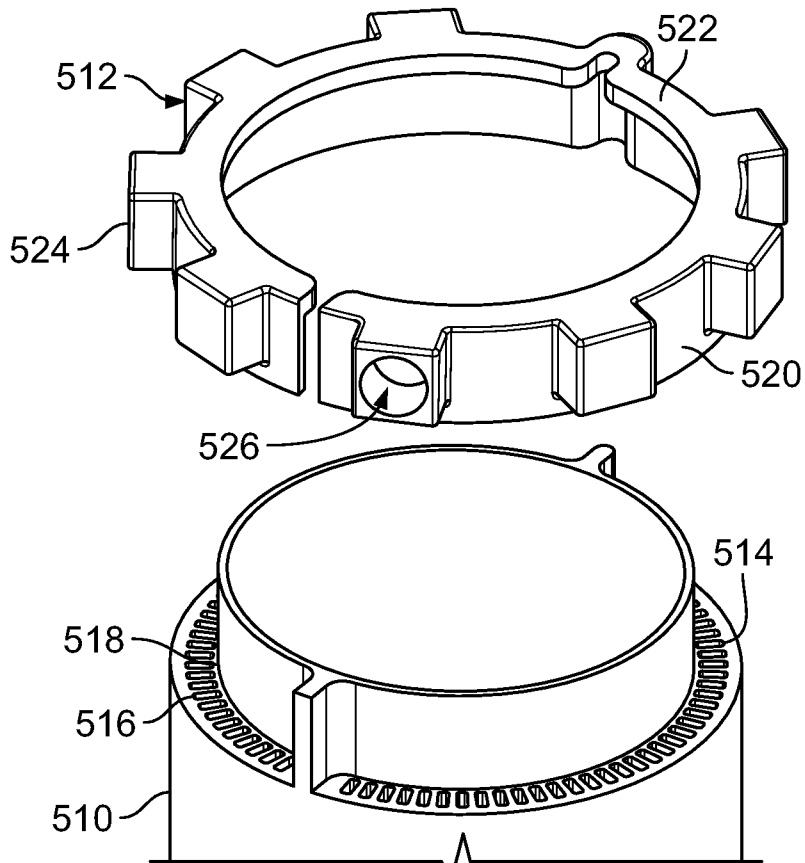

FIG. 23F

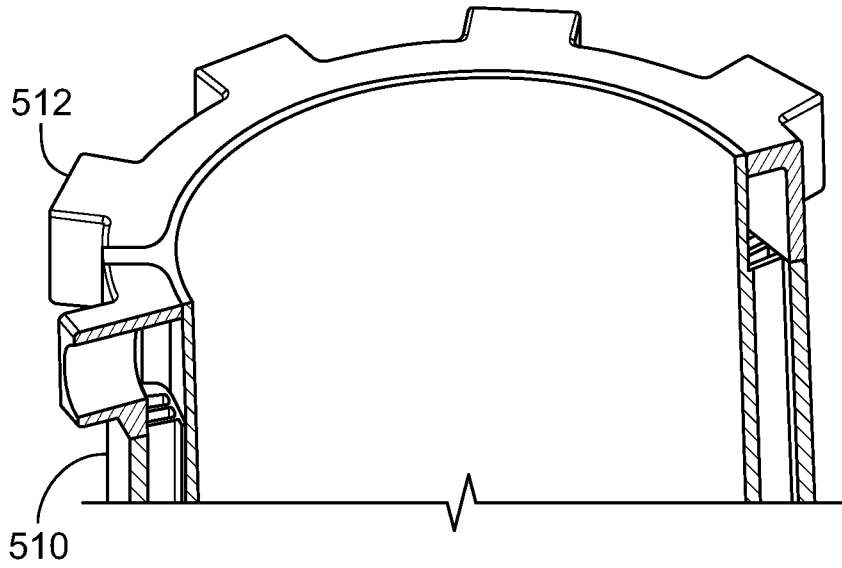

FIG. 23G

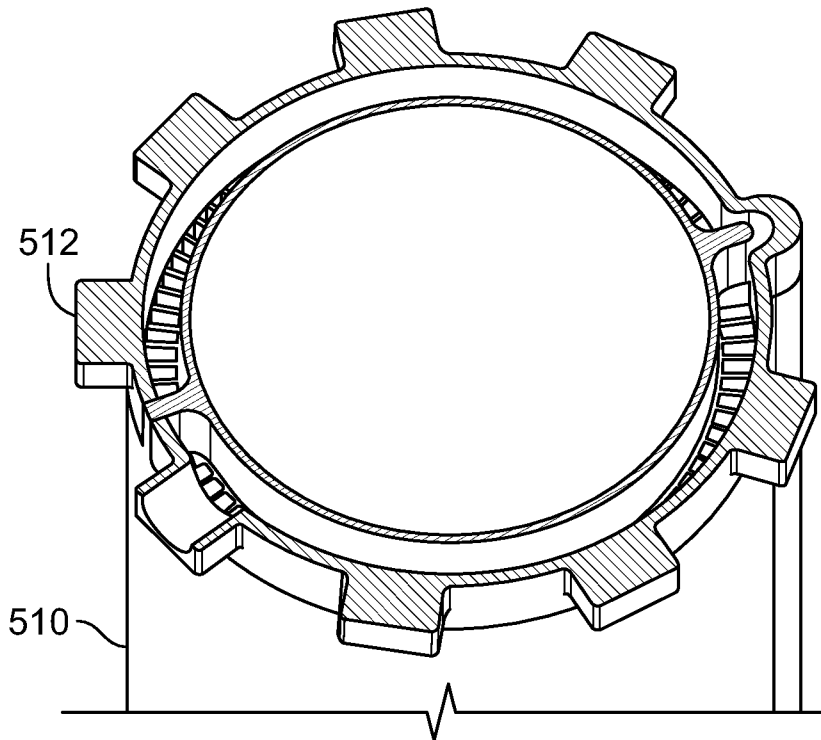

FIG. 23H

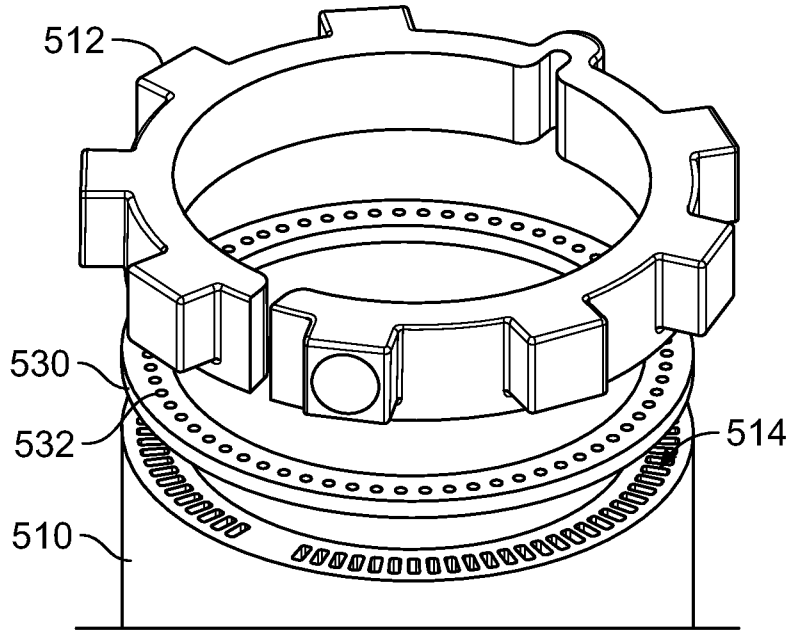

FIG. 24

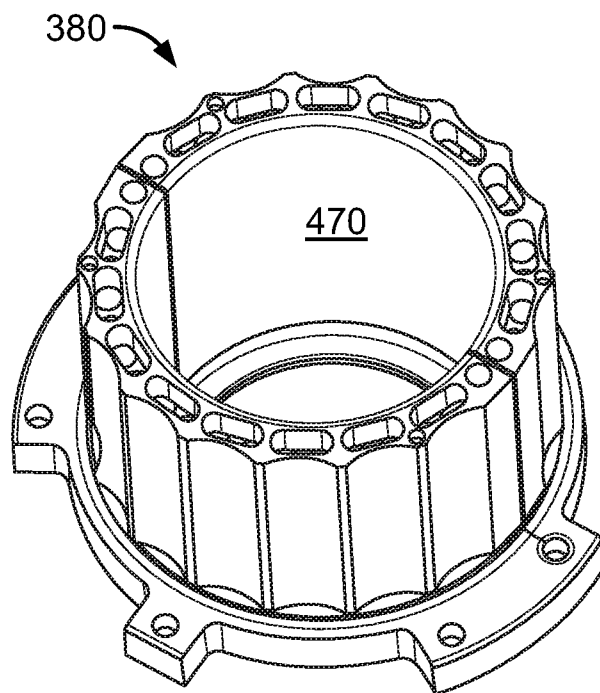
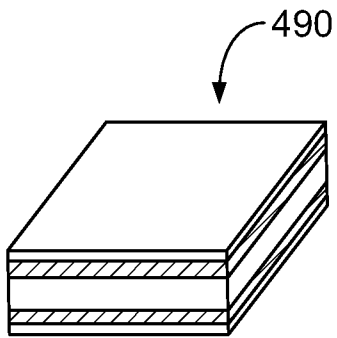
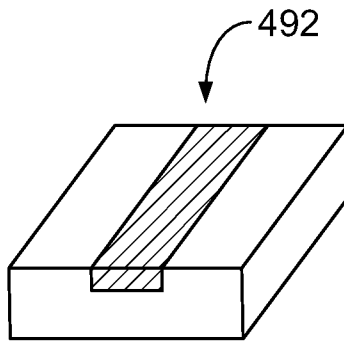

FIG. 25
(f23)



Overlay Clad
FIG. 26A



Inlay Clad
FIG. 26B

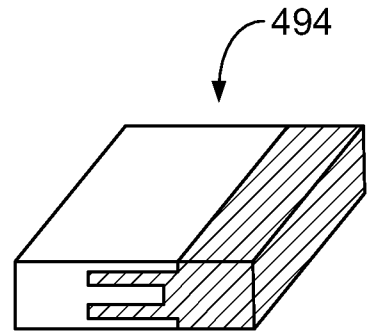

Edge Clad
FIG. 26C

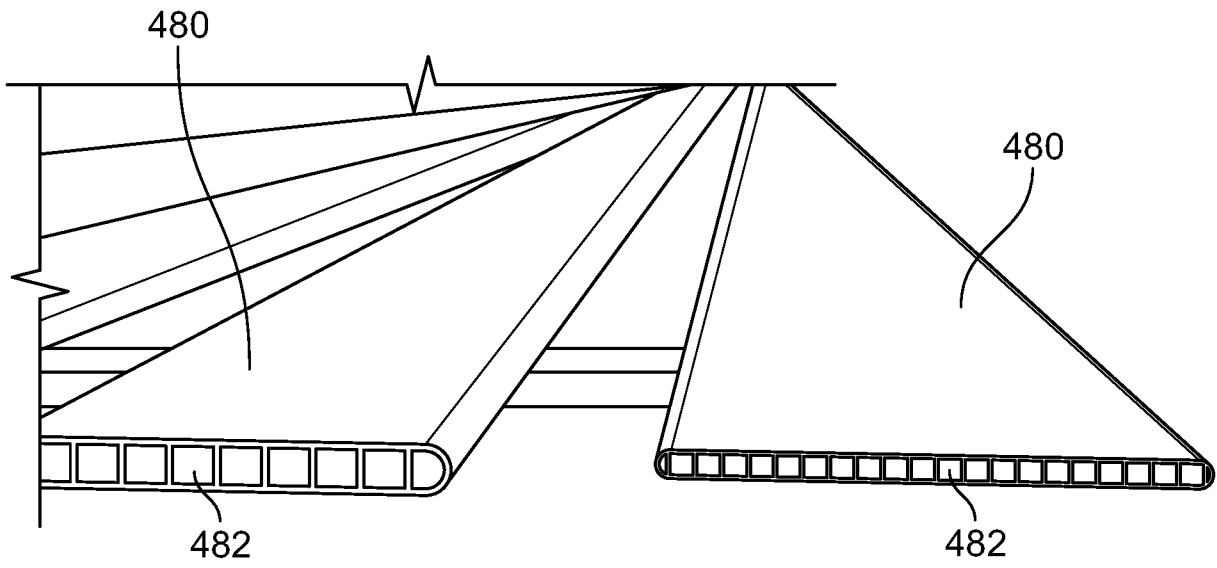

FIG. 27

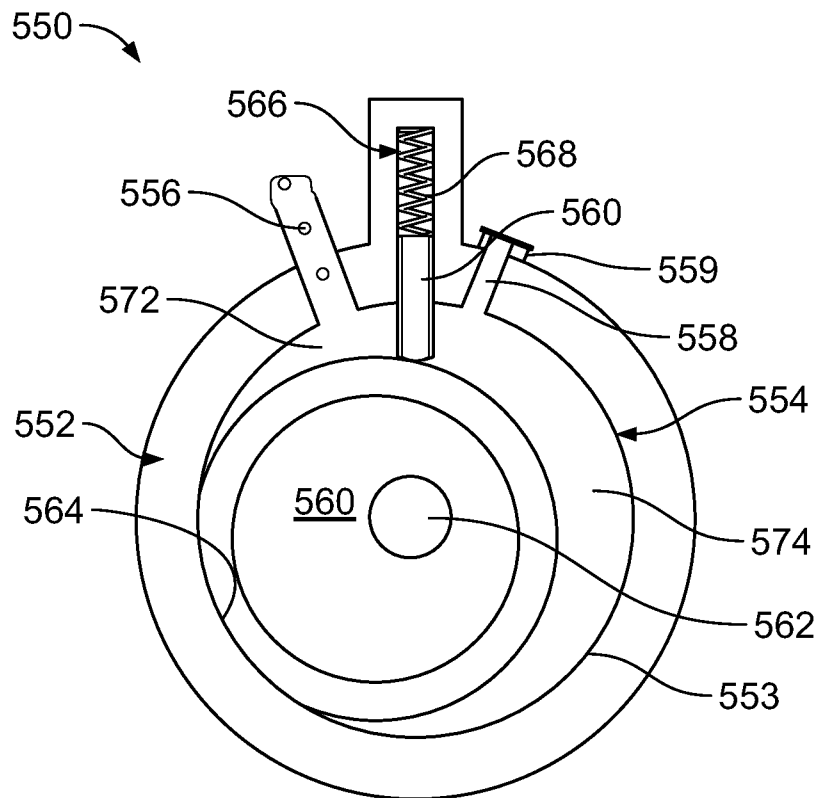

FIG. 28A

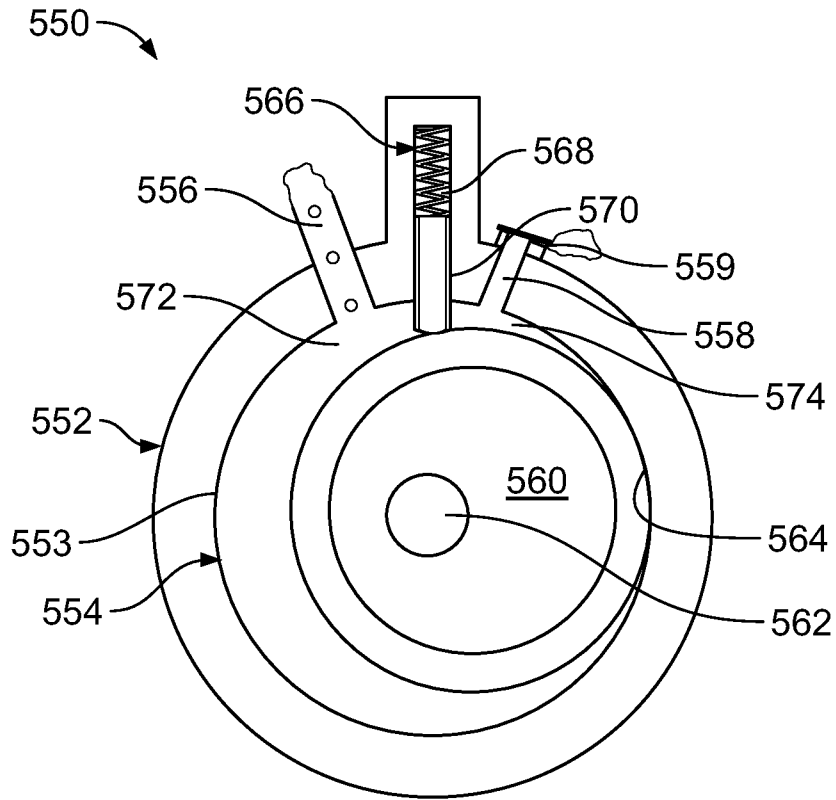

FIG. 28B

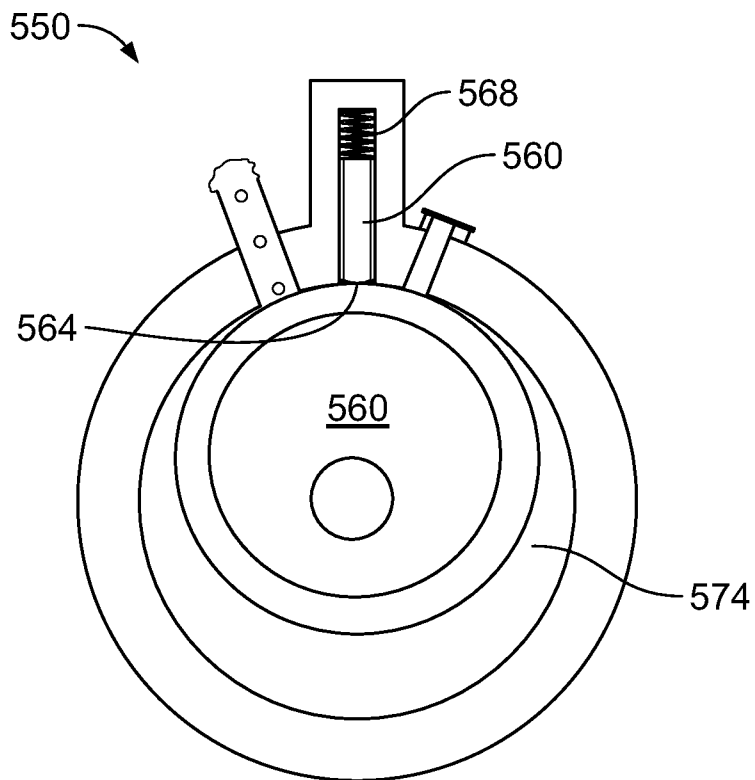

FIG. 28C