

No. 845,148.

PATENTED FEB. 26, 1907.

D. T. VANLANINGHAM.
MAGAZINE HAMMER.

APPLICATION FILED APR. 4, 1906.

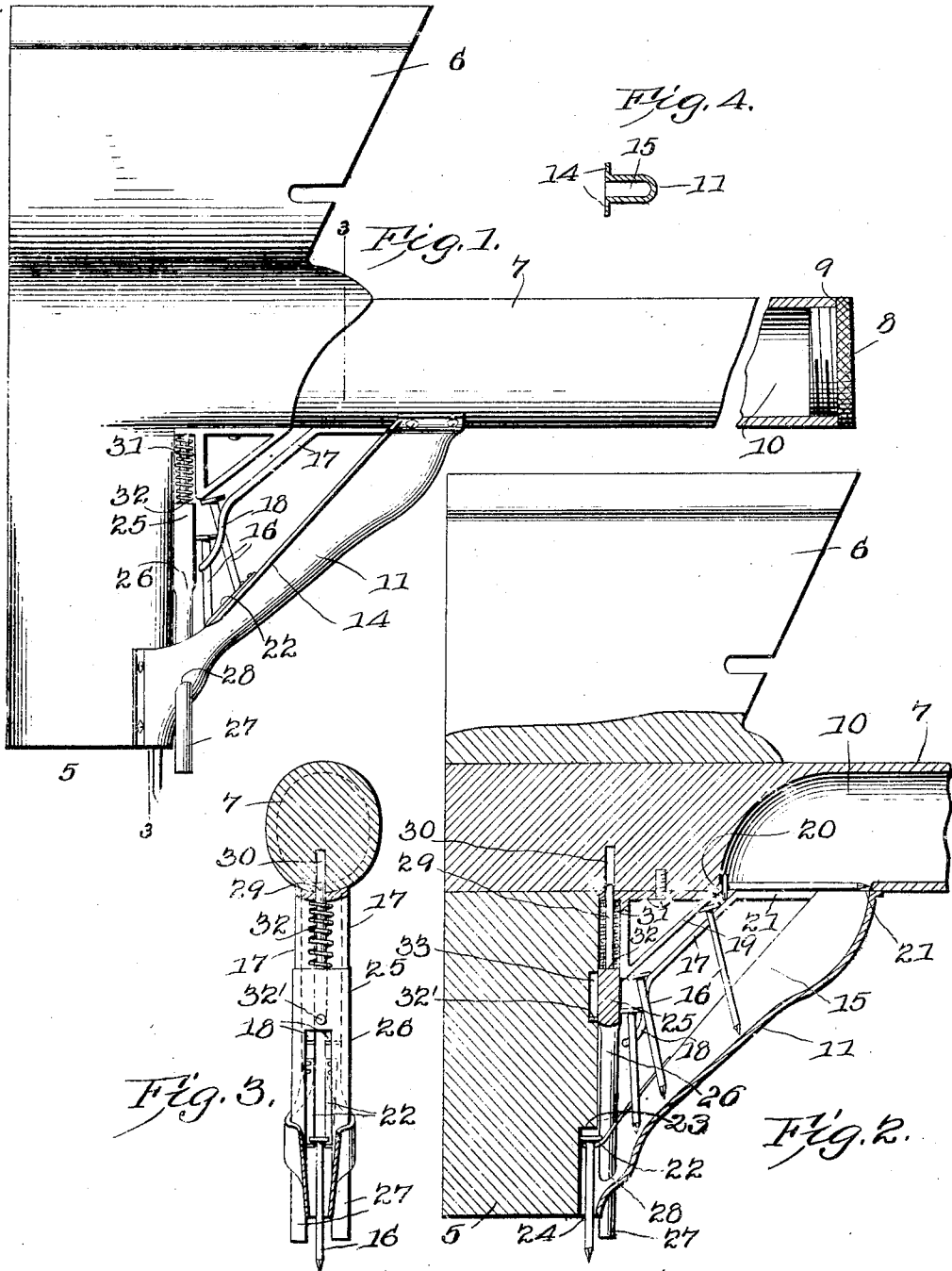

WITNESSES:
[Signature]
[Signature]

Daniel T. Vanlaningham, INVENTOR

By *Cashmore*
ATTORNEYS

UNITED STATES PATENT OFFICE.

DANIEL T. VANLANINGHAM, OF YOUNGSTOWN, MISSOURI.

MAGAZINE-HAMMER.

No. 845,148.

Specification of Letters Patent.

Patented Feb. 26, 1907.

Application filed April 4, 1906. Serial No. 309,881.

To all whom it may concern:

Be it known that I, DANIEL T. VANLANINGHAM, a citizen of the United States, residing at Youngstown, in the county of Adair and State of Missouri, have invented a new and useful Magazine-Hammer, of which the following is a specification.

This invention relates to magazine hatchets, hammers, and similar tools, and has for its object to provide an inexpensive and efficient tool of this character in which the nails or tacks are automatically fed from the magazine to the driving-head of the tool, so that the nails may be successively positioned and driven without the necessity of handling the same.

A further object of the invention is to provide means for guiding the nails in their passage from the magazine to the discharge-chute and means for presenting the point of one nail to the work when the succeeding nail has been driven.

A still further object of the invention is to generally improve this class of devices so as to increase their utility, durability, and efficiency, as well as to reduce the cost of manufacture.

With these and other objects in view the invention consists in the construction and novel combination and arrangement of parts hereinafter fully described, and illustrated in the accompanying drawings, it being understood that various changes in form, proportions, and minor details of construction may be resorted to within the scope of the appended claims.

In the accompanying drawings, forming a part of this specification, Figure 1 is a side elevation of a portion of a magazine-hatchet constructed in accordance with my invention. Fig. 2 is a longitudinal sectional view of the same. Fig. 3 is a transverse sectional view taken on the line 3-3 of Fig. 1. Fig. 4 is a transverse sectional view of the feed trough or chute.

Similar numerals of reference indicate corresponding parts in all of the figures of the drawings.

The self-feeding attachment is shown in connection with a hatchet, in which 5 designates the driving-head, 6 the blade, and 7 the handle, the latter being preferably formed hollow and provided with a removable screw-cap 8, which normally closes an opening 9, through which the nails or tacks may be introduced into the magazine 10.

Secured to the driving-head and handle, respectively, is an inclined discharge chute or trough 11, preferably U-shaped in cross-section, as shown, and provided with laterally-projecting flanges 12, through which extend screws or similar fastening devices 13 for securing the chute in position.

The chute or trough 11 communicates with the magazine 10, and the adjacent longitudinal edges of said trough are provided with laterally-extending flanges 14, spaced apart to form a guide 15 for the points of the nail 16 in their passage from the magazine to the driving-head of the tool. Spaced from the open end of the trough 11 and secured in any suitable manner to the handle 7 are parallel arms 17, terminating in spring lips or ears 18, adapted to support and guide the heads of the nails, and disposed above said arms and fastened in any suitable manner to the handle of the tool is a triangular-shaped block 19, designed to prevent accidental displacement of said nails.

The head proper of the tool is provided with a projection or deflecting-cam 20, which extends between the parallel arms 17 at the juncture of the latter with the handle 7, so that should the heads of the nails be presented through the openings 21 in their passage to the trough said heads will engage the cam 20, and thus cause the points of the nails to enter the trough, and in which position the heads of the nails are free to pass beneath the cam and engage the arms 17. Should the nails be fed point first to the trough, it is obvious that the points of the nails will enter the opening 21 and permit the heads of the same to clear the cam in the manner before stated. Secured to the lateral flanges 14 of the feed-trough are spring retaining-fingers 22, adapted to engage the heads of the nails as the latter are successively presented to the work and hold each nail with its head spaced from an anvil 23 and with its point projecting through an opening 24 in the trough, as best shown in Fig. 2 of the drawings.

Slidably mounted on the head of the tool is a spring-actuated nail-carrier 25, having one end thereof bifurcated to form a nail-receiving recess 26, defining a pair of spaced tripping-arms 27, which project through correspondingly-shaped openings 28, formed in the adjacent end of the feed-trough 11, the opposite end of the nail-carrier being provided with a reduced extension 29, adapted to enter a guiding-recess 30, there being

a coiled spring 31 interposed between the shoulders 32 of the carrier and the block 19 for normally holding the trip-arms extended beyond the active face of the driving-head.

5 As a means for limiting the longitudinal movement of the nail-carrier the latter is provided with a pin or projection 32', adapted to engage the walls of a slot or opening 33, formed in the head of the tool, as shown.

10 It will thus be seen that when the first nail has been driven or partially driven into the work the trip-arms 27 by engagement with said work will depress the nail-carrier and move the latter longitudinally against the

15 tension of the spring 31 until the nail-receiving recess 26 registers with the adjacent nail carried by the spring-lips 18, thus permitting the nail to drop into the recess, so that when the tool is elevated above the work said nail

20 will drop by gravity into engagement with the spring-fingers 22 and be supported in position against the anvil 23. As soon as a pressure on the trip-arms is released by elevating the tool above the work the spring

25 will automatically return the carrier to normal or inoperative position over the spring-lips 18, thus locking the nails in engagement with the parallel arms 17 until the carrier is again reciprocated.

30 Attention is called to the fact that the block 19 not only serves as a means for preventing accidental displacement of the nails, but also serves as a means for guiding the carrier. It will thus be seen that the nails

35 are automatically fed to the driving-head of the tool without the necessity of handling the same, while, by reason of the slotted-nail-carrier, but a single nail will be presented to the work at a time.

40 While the automatic feeding device is shown in connection with a hatchet, it is obvious that the same may be used on a hammer or any other tool in which a device of this kind is found desirable.

45 Having thus described the invention, what is claimed is—

1. In a device of the class described, a tool having a driving-head and provided with a

50 magazine, a discharge-chute communicating with the magazine; guide-arms disposed above the chute and provided with terminal spring-lips, an anvil carried by the driving-head, spring-fingers secured to the discharge-

55 chute and disposed at said anvil for engagement with the nails, and a sliding nail-carrier having a recess formed therein and adapted to successively receive the nails and deliver the same to the spring-fingers.

60 2. In a device of the class described, a driving-head provided with a nail-receiving

magazine, a discharge-chute communicating with the magazine, guiding-arms disposed above the discharge-chute and provided with terminal spring-lips, a block spaced from the

65 guiding-arms, and a spring-actuated nail-carrier slidably mounted between the head of the tool and the block, for successively presenting the nails to the driving-head.

3. In a device of the class described, a tool

70 having a driving-head and provided with a nail-receiving magazine, an anvil carried by the driving-head, a discharge-chute communicating with the magazine, guiding-arms disposed above the discharge-chute and provided with terminal resilient lips, a spring-

75 actuated nail-carrier slidably mounted on the tool for successively delivering the nails to the driving-head, a pin carried by the nail-carrier and operating within a slot in the tool

80 for limiting the sliding movement of said nail-carrier, and spring-fingers secured to the chute for supporting the nails at said anvil.

4. In a device of the class described, a tool

85 having a driving-head and provided with a hollow handle constituting a nail-receiving magazine, an anvil carried by the driving-head, a substantially U-shaped discharge-

90 chute communicating with the magazine and having a nail-delivery opening formed in one end thereof, guide-arms spaced from the discharge-chute and provided with terminal

95 lips the free ends of which are concaved, a spring-actuated nail-carrier having one end thereof bifurcated to form a nail-receiving

100 recess and provided with terminal trip-arms extending through openings in the discharge-chute, a spring interposed between the nail-carrier in the adjacent wall of the tool, and means for limiting the sliding movement of

105 said nail-carrier.

5. In a device of the class described, a tool having a driving-head and provided with a hollow handle constituting a nail-receiving

110 magazine, a discharge-chute communicating with the magazine, an auxiliary chute spaced from the discharge-chute and provided with terminal spring portions adapted to support the heads of the nails, a substantially triangular-shaped block secured to the handle and

115 arranged adjacent the auxiliary chute, and a spring-actuated nail-carrier having a recess formed therein adapted to receive the nails and deliver the same successively to the driving-head.

In testimony that I claim the foregoing as my own I have hereto affixed my signature in the presence of two witnesses.

DANIEL T. VANLANINGHAM.

Witnesses:

GEORGE W. BERRY,
HERNDON OSBORNE.