



MX, MZ, NO, NZ, PH, PL, PT, RO, RU, SD, SE, SG, SI, SK, SL, TJ, TM, TR, TT, TZ, UA, UG, US, UZ, VN, YU, ZA, ZW.

(84) Designated States (regional): ARIPO patent (GH, GM, KE, LS, MW, MZ, SD, SL, SZ, TZ, UG, ZM, ZW), Eurasian patent (AM, AZ, BY, KG, KZ, MD, RU, TJ, TM), European patent (AT, BE, CH, CY, DE, DK, ES, FI, FR, GB, GR, IE, IT, LU, MC, NL, PT, SE, TR), OAPI patent (BF, BJ, CF, CG, CI, CM, GA, GN, GQ, GW, ML, MR, NE, SN, TD, TG).

Published:

- with international search report
- before the expiration of the time limit for amending the claims and to be republished in the event of receipt of amendments

For two-letter codes and other abbreviations, refer to the "Guidance Notes on Codes and Abbreviations" appearing at the beginning of each regular issue of the PCT Gazette.

A DELIVERY DEVICE

The present invention relates to a manually actuated delivery device for the delivery of a volume of liquid, in particular, a liquid containing medicament.

WO 92/20455 discloses one example of such a delivery device which takes the form of a nasal inhaler for the delivery of a volume of liquid containing medicament as a spray into a nasal cavity. This delivery device includes a nosepiece in the form of an applicator portion for insertion into a nasal cavity. The applicator portion delivers the spray and is configured to be manually actuated by the application of a force axially relative to the longitudinal axis of the nosepiece.

Whilst such a delivery device is capable of delivering a metered volume of liquid, the use of the delivery device for delivery of a nasal spray can prove troublesome since the axial application of force tends to cause axial movement of the applicator portion within the nasal cavity which can lead to inefficient delivery of the liquid.

The present invention aims to overcome the problem of axial movement of the applicator portion by providing a delivery device configured such that the force for manual actuation is applied substantially orthogonally to the axis of delivery of the liquid. With such a configuration, inadvertent withdrawal or movement of the applicator portion can be obviated.

A further advantage of the present invention is the provision of a counting mechanism which indicates to the user how many doses of liquid have been delivered.

According to the present invention, there is provided a manually actuated delivery device for the delivery of a dose of liquid comprising a housing which includes an outlet through which liquid, in use, is delivered, an actuating member which is moveably disposed relative to the housing between a first position and a second position, the user moving the actuating member into the second position to actuate the delivery device and a liquid delivery assembly which is located at least partly within the housing, the liquid delivery assembly comprising a liquid delivery unit, a carrier unit for moving the liquid delivery unit along the longitudinal axis of the device and a coupling member which couples the movement of the actuating member and the carrier unit, characterised in that movement of the carrier unit along the longitudinal axis of the device activates a counting mechanism which indicates how many doses have been delivered.

Preferably, the carrier unit comprises at least one toothed ratchet finger which cooperates with a gear member of the counting mechanism.

Preferably, the gear member engages a toothed counting ring of the counting mechanism.

Preferably, the tooth pitch on the ratchet finger is constructed such that the gear member moves the toothed counting ring forward by one tooth for each dose delivered.

Preferably, anti-back drive means are provided to prevent the toothed counting ring rotating in a reverse direction.

Preferably, the anti-back drive means are located on the counting ring.

Preferably, the anti-back drive means are located on the internal surface of the housing.

Preferably, the anti-back drive means are in the form of a ratchet arm which engages the gear member.

Preferably, the gear member has an outer set of teeth which engage the toothed ratchet finger and an inner set of teeth which engage the toothed counting ring.

Preferably, the actuating member is a cover member which is moveably disposed between the first position in which the cover member at least partly covers the outlet and the second position in which the cover member acts as a lever which lifts the carrier unit.

Preferably, a seal is located within the cover member to seal the outlet when in the first position.

Preferably, the housing comprises an applicator portion with an outlet nozzle, the outlet nozzle being removable to enable cleaning.

Preferably, the outlet nozzle is threaded and cooperates with a threaded socket in the applicator base portion.

Preferably, the outlet nozzle "snaps" into the final position in the threaded socket.

According to a further aspect of the present invention, there is provided a manually actuated delivery device for delivery of a dose of liquid comprising a

housing which includes an outlet through which liquid, in use, is delivered, and a cover member which is moveable between a first position in which the outlet is covered and a second position in which the outlet is exposed characterised in that a seal is located within the cover member to seal the outlet when in the first position.

Preferably, the cover member is hinged on the housing.

Preferably, the cover member is a snap-fit on the housing.

Preferably, the cover member has a screw-thread which cooperates with a screw-thread on the housing.

Preferred embodiments of the present invention will now be described in detail, by way of example only, with reference to the accompanying drawings, of which:

Figure 1 is an exploded view from above of a first embodiment of the delivery device;

Figure 1a is an enlarged view in direction A in Figure 1 of the upper part of the internal surface of the lower body portion;

Figure 2 is an exploded view from below of the first embodiment of the delivery device;

Figure 3 is a perspective view of the assembled delivery device when closed;

Figure 4 is a perspective view of the delivery device in Figure 3 when opened;

Figure 5 is a partial sectional view of the delivery device in Figure 3 (without the counting ring);

Figure 6 is a perspective view from above of the interactive elements of the counting mechanism of the delivery device;

Figure 7 is a side view of the elements of the delivery device in Figure 6;

Figure 8 is a perspective view from below of the elements of the delivery device in Figure 6;

Figure 9 is a view from below of the upper body portion of the housing;

Figures 10a to 10d are various views of the delivery device with the cover member in the closed position;

Figures 11a to 11d are various views of the delivery device with the cover member in the open position prior to actuation;

Figures 12a to 12d are various views of the delivery device at the point of actuation;

Figure 13 is an exploded perspective view from above of a second embodiment of the delivery device;

Figure 14 is an exploded perspective view from below of the second embodiment of the delivery device; and,

Figures 15 and 16 depict an alternative anti-back drive mechanism.

The delivery device depicted in Figures 1 and 2 comprises a housing 1, having an applicator portion 1a, an upper body portion 1b, a lower body portion 1c and a base portion 1d, an actuating member 2 and a liquid delivery assembly 3.

The liquid delivery assembly 3 comprises a liquid delivery unit 4, a carrier unit 5 which carries the liquid delivery unit 4 and a coupling member 6 which couples the movement of the actuating member 2 and the carrier unit 5.

The actuating member 2 is in the form of a cover member and is moveable relative to the housing 1 (1a, 1b, 1c, 1d) between a first position to a second position which actuates the delivery device. Although the actuating member 2 is shown as a cover which pivots on the coupling member 6, it will be appreciated that other forms of actuating member could be used, the requirement being that in the second position, the actuating member moves the carrier unit 5 as required.

The delivery device also comprises a counting mechanism 7a, 7b which indicates to the user how many doses of liquid have been delivered. This feature helps to avoid the user attempting to actuate the delivery device when empty and also serves as a reminder that a replacement delivery device should be obtained when only a few doses remain.

Figure 2 gives a different perspective of the exploded view in Figure 1, showing the elements from below rather than above.

Figure 3 is a perspective view of the assembled delivery device with the cover member 2 in the first position (closed) prior to actuation by a user. Figure 4 depicts the delivery device when the cover member 2 has been moved into the open position prior to actuation.

Figure 5 is a partial sectional view through the delivery device in Figure 3 with the housing 1 and cover member 2 sectioned and the internal elements non-sectioned. The counting ring 7b of the counting mechanism has been removed to enable the remaining internal elements to be seen more clearly.

The cover member 2 has a basic hollow domed shape contoured to fit over the applicator portion 1a. A tapered tip 8 with a series of gripping ridges 9 facilitates opening of the delivery device. The cover member 2 is also provided with an extension 10 which carries spaced pins 11a, 11b which sit in sockets 12a, 12b on the coupling member 6. The applicator portion 1a has a slot 13 into which a locking member 14 on the cover member 2 fits to hold the cover member 2 in position when closed. The locking member 14 should be configured such that the user has to apply little force to the tapered tip 8 to make the cover member 2 pivot into the open position.

The main elements of the liquid delivery assembly 3 are clearly visible in Figure 5. The liquid delivery assembly 3 comprises a liquid delivery unit 4, a carrier unit 5 for the liquid delivery unit and the coupling member 6.

The liquid delivery unit 4 comprises a container 13 and a pump 14 having a tubular nozzle 15. The tubular nozzle 15 is slidable into the container 13 against the action of an internal spring (not shown) to deliver a volume of liquid.

The carrier unit 5 comprises a cage 16 constructed to sit around the pump 14 and tubular nozzle 15 of the liquid delivery unit 4. The cage 16 holds and carries the liquid delivery unit 4 during actuation. At the upper end of the cage 16 are spaced arms 17a, 17b, each of which has a hook 18a, 18b configured to rest on the coupling member 6 when the delivery device is assembled. A resilient toothed ratchet finger 19 extends from the lower end of the cage 16 and cooperates with a gear member 7a of the counting mechanism.

The coupling member 6 is in the form of a yoke which can pivot on the upper body portion 1b of the housing. Projections 20a, 20b on each side of the coupling member 6 sit in sockets 21a, 21b on each side of a lateral opening 22 in the upper body portion 1b. The applicator portion 1a is also provided with a lateral opening 23 to accommodate the pivoting movement of the coupling member 6.

The counting mechanism comprises a counting ring 7b and a gear member 7a which interact with the toothed ratchet finger 19. As is evident from Figures 5 to 8, any movement of the toothed ratchet finger 19 will turn the gear member 7a via the outer set of teeth 24 which in turn will result in the inner set of teeth 25 on the gear member 7a turning the counting ring 7b. The tooth pitch on the ratchet finger 19 is designed such that the gear member 7a moves the counting ring 7b forward by one

tooth for each dose delivered. The gear member 7a sits in a gear pocket 49 (Figure 1a) on the upper internal surface of the lower body portion 1c. The counting ring 7b will typically be calibrated with an indication of how many doses remain and this number will be visible through a window 26 in the upper body portion 1b. A transparent cover 27 for the window is provided to prevent the internal mechanism becoming clogged with particles of dust or dirt, for example, and to prevent tampering.

The upper body portion 1b is depicted in Figure 9 viewed from below. On the internal surface a ring of teeth 28 is provided which will cooperate with four anti-back drive fingers 29 on the counting ring 7b. The circumferential position of the teeth 28 is arranged to have a vernier action such that only one of the four fingers 29 will be engaged at any time. The delivery device is designed to lift the ratchet finger 19 upwards during actuation driving the gear member 7a in a clockwise direction (see Figure 7). The outer set of teeth 24 on the gear member 7a then turn by one tooth in a clockwise direction as the ratchet finger 19 moves upwards by one tooth. However, after actuation when the ratchet finger 19 moves downwards on the return stroke, there will be a tendency to turn the gear member 7a in an anticlockwise direction and hence a tendency to turn the counting ring 7b in a reverse direction. The anti-back drive fingers 29 are provided to prevent any reverse rotation of the counting ring 7b which would affect the counting mechanism and possibly distort the true reading of the remaining doses.

The upper body portion 1b is also provided with suitable projections 30, 31 on the open ends which serve to lock the housing portions together during assembly. Cooperating recesses or projections can also be found on the applicator portion 1a, the lower body portion 1c and the base portion 1d.

Preferably, the cover member 2 has a seal 33 which sits in the tapered tip 8 which ensures that the outlet nozzle 34 of the applicator portion 1a is suitably sealed when the cover member 2 is in the closed position. A tubular feed 35 sits above the tubular nozzle 15 of the liquid delivery unit 4 and extends into the outlet nozzle 34. The tubular feed 35 guides the dose of liquid from the tubular nozzle 15 to the outlet 36 in the outlet nozzle 34.

Whilst the seal 33 has been described with reference to the particular delivery device described and depicted in Figures 1 to 16, it will be appreciated that such a seal could be incorporated into a wide range of alternative delivery devices which feed a liquid to an outlet nozzle. For example, the cover member could be a snap-fit onto the outlet nozzle or could have a screw-thread. The cover member should in all cases be constructed such that the seal 33 is held with a substantially constant pressure against the outlet nozzle.

Figures 13 and 14 depict a second embodiment of the present invention which differs only in that the outlet nozzle 34' is removable from the base 37' of the applicator portion 1 for cleaning purposes. A screw thread 38' is provided on the outlet nozzle 34' with a correspondingly threaded socket 39' in the base 37'. At the end of the screw thread 38' a projection 40' provides a "snap-action" to indicate to the user that the outlet nozzle 34' has been correctly replaced.

In use, a user takes the delivery device in one hand and flips the cover member 2 from the closed position into the open position. See Figures 10a, 10b, 10c and 10d which depict various views of the delivery device with the cover member 2 in the closed position. Figures 11a, 11b, 11c and 11d depicts the delivery device after the cover member 2 has pivoted into the open position via pins 11a, 11b in sockets 12a, 12b.

The delivery device should then be positioned with the outlet nozzle 34 in a nasal cavity. The user then applies further pressure on the cover member 2 such that the coupling member 6 pivots via projections 20a, 20b in sockets 21a, 21b in the upper body portion 1b. The coupling member 6 then starts to lift the carrier unit 5 by cooperation with the hooks 18a and 18b on arms 17a and 17b. See Figures 12a, 12b, 12c and 12d.

Since the liquid delivery unit 4 is carried by the carrier unit 5, the container 13, pump 14 and tubular nozzle 15 all move upwards until the tubular feed 35 forces the tubular nozzle 15 into the container 13 to actuate liquid delivery by way of pump 14.

During actuation the toothed ratchet finger 19 engages the counting mechanism as described earlier to move the counting ring 7b and display through window 26 how many doses remain.

After actuation, the user removes pressure on the cover member 2 which allows the coupling member 6 to return to the position in Figures 11a to 11d. The cover member 2 should then be pivoted back to the closed position until a further dose is required.

Figures 15 and 16 depict an alternative anti-back drive mechanism. The four anti-back drive fingers 29 on the counting ring 7b have been replaced by a ratchet arm 50 which extends from the internal surface of the lower body portion 1c. The ring of the teeth 28 are no longer necessary on the internal surface of upper body portion 1b. In Figure 15, the lower body portion 1c is only shown in part so that the locations of the carrier 16 and ratchet arm 50 are clearly visible.

The ratchet arm 50 extends into a gear pocket 51 which is located on the internal surface of the lower body portion 1c. As in the earlier embodiment described

with reference to Figures 7, 8 and 9, the ratchet arm 50 will prevent the gear member 7a from turning in an anticlockwise direction (in Figure 15) when ratchet finger 19 moves downwards on the return stroke. The ratchet arm 50 has two teeth 52 and 53 which allow clockwise rotation of the gear member 7a but act as a back-stop against anticlockwise rotation. The provision of two teeth 52,53 helps to reduce backlash.

Figure 16 is a perspective view from below of the upper and lower body portions 1b, 1c with gear pocket 51, ratchet finger 19 and ratchet arm 50 visible.

CLAIMS:

1. A manually actuated delivery device for the delivery of a dose of liquid comprising a housing which includes an outlet through which liquid, in use, is delivered, an actuating member which is moveably disposed relative to the housing between a first position and a second position, the user moving the actuating member into the second position to actuate the delivery device and a liquid delivery assembly which is located at least partly within the housing, the liquid delivery assembly comprising a liquid delivery unit, a carrier unit for moving the liquid delivery unit along the longitudinal axis of the device and a coupling member which couples the movement of the actuating member and the carrier unit, characterised in that movement of the carrier unit along the longitudinal axis of the device activates a counting mechanism which indicates how many doses have been delivered.

2. A manually actuated delivery device as claimed in Claim 1, wherein the carrier unit comprises at least one toothed ratchet finger which cooperates with a gear member of the counting mechanism.

3. A manually actuated delivery device as claimed in Claim 2, wherein the gear member engages a toothed counting ring of the counting mechanism.

4. A manually actuated delivery device as claimed in Claim 3, wherein the tooth pitch on the ratchet finger is constructed such that the gear member moves the toothed counting ring forward by one tooth for each dose delivered.

5. A manually actuated delivery device as claimed in Claim 3 or Claim 4, wherein anti-back drive means are provided to prevent the toothed counting ring rotating in a reverse direction.

6. A manually actuated delivery device as claimed in Claim 5, wherein the anti-back drive means are located on the counting ring.

7. A manually actuated delivery device as claimed in Claim 5, wherein the anti-back drive means are located on the internal surface of the housing.

8. A manually actuated delivery device as claimed in Claim 7, wherein the anti-back drive means are in the form of a ratchet arm which engages the gear member.

9. A manually actuated delivery device as claimed in any of Claims 3 to 8, wherein the gear member has an outer set of teeth which engage the toothed ratchet finger and an inner set of teeth which engage the toothed counting ring.

10. A manually actuated delivery device as claimed in any preceding claim, wherein the actuating member is a cover member which is moveably disposed between the first position in which the cover member at least partly covers the outlet and the second position in which the cover member acts as a lever which lifts the carrier unit.

11. A manually actuated delivery device as claimed in Claim 10, wherein a seal is located within the cover member to seal the outlet when in the first position.

12. A manually actuated delivery device as claimed in any preceding claim, wherein the housing comprises an applicator portion with an outlet nozzle, the outlet nozzle being removable to enable cleaning.

13. A manually actuated delivery device as claimed in Claim 12, wherein the outlet nozzle is threaded and cooperates with a threaded socket in the applicator base portion.

14. A manually actuated delivery device as claimed in Claim 13, wherein the outlet nozzle "snaps" into the final position in the threaded socket.

15. A manually actuated delivery device for delivery of a dose of liquid comprising a housing which includes an outlet through which liquid, in use, is delivered, and a cover member which is moveable between a first position in which the outlet is covered and a second position in which the outlet is exposed characterised in that a seal is located within the cover member to seal the outlet when in the first position.

16. A manually actuated delivery device as claimed in Claim 15, wherein the cover member is hinged on the housing.

17. A manually actuated delivery device as claimed in Claim 15, wherein the cover member is a snap-fit on the housing.

18. A manually actuated delivery device as claimed in Claim 15, wherein the cover member has a screw-thread which cooperates with a screw-thread on the housing.

19. A manually actuated delivery device substantially as herein described with reference to the accompanying drawings.

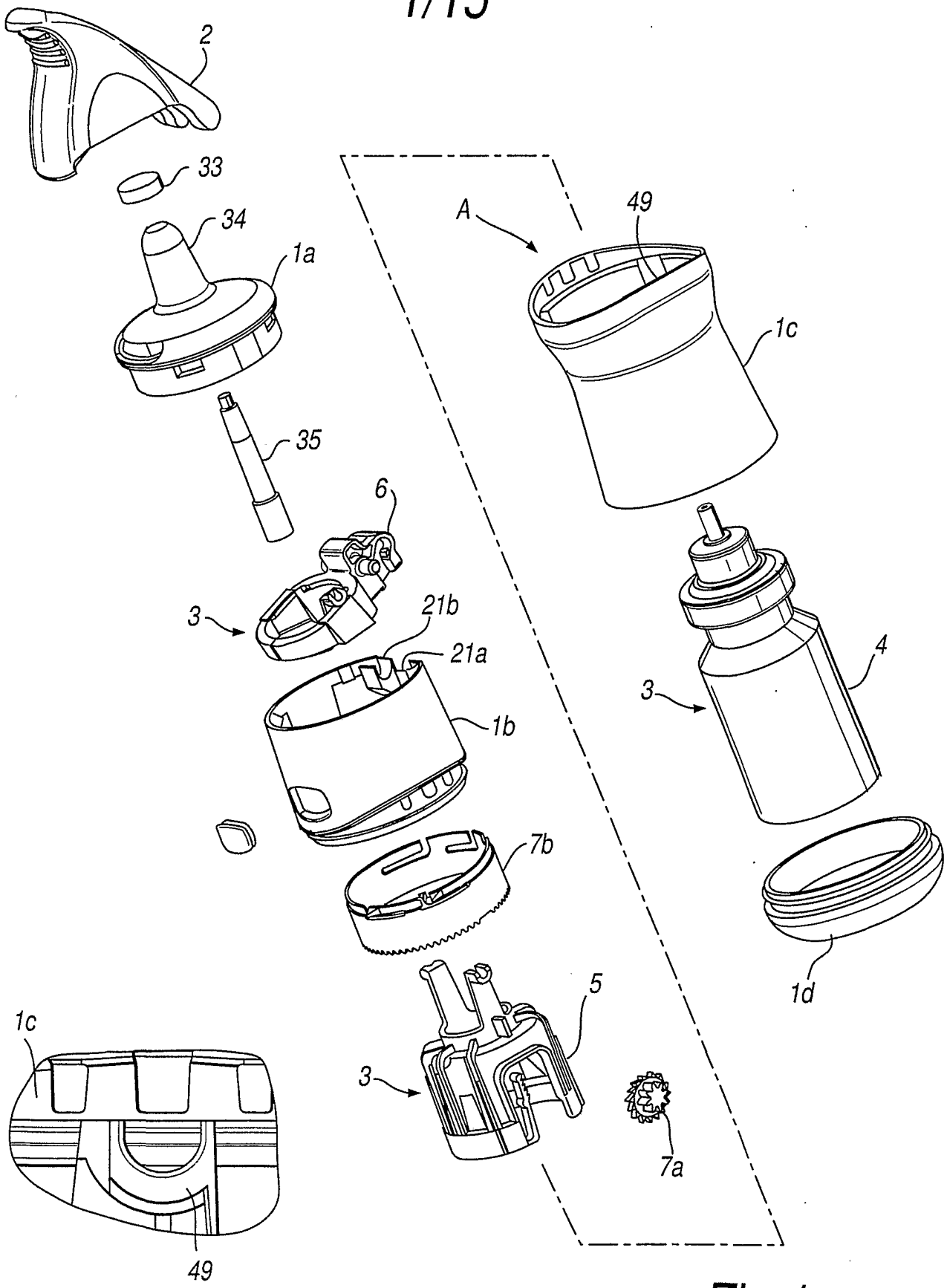

Fig. 1a

Fig. 1

2/15

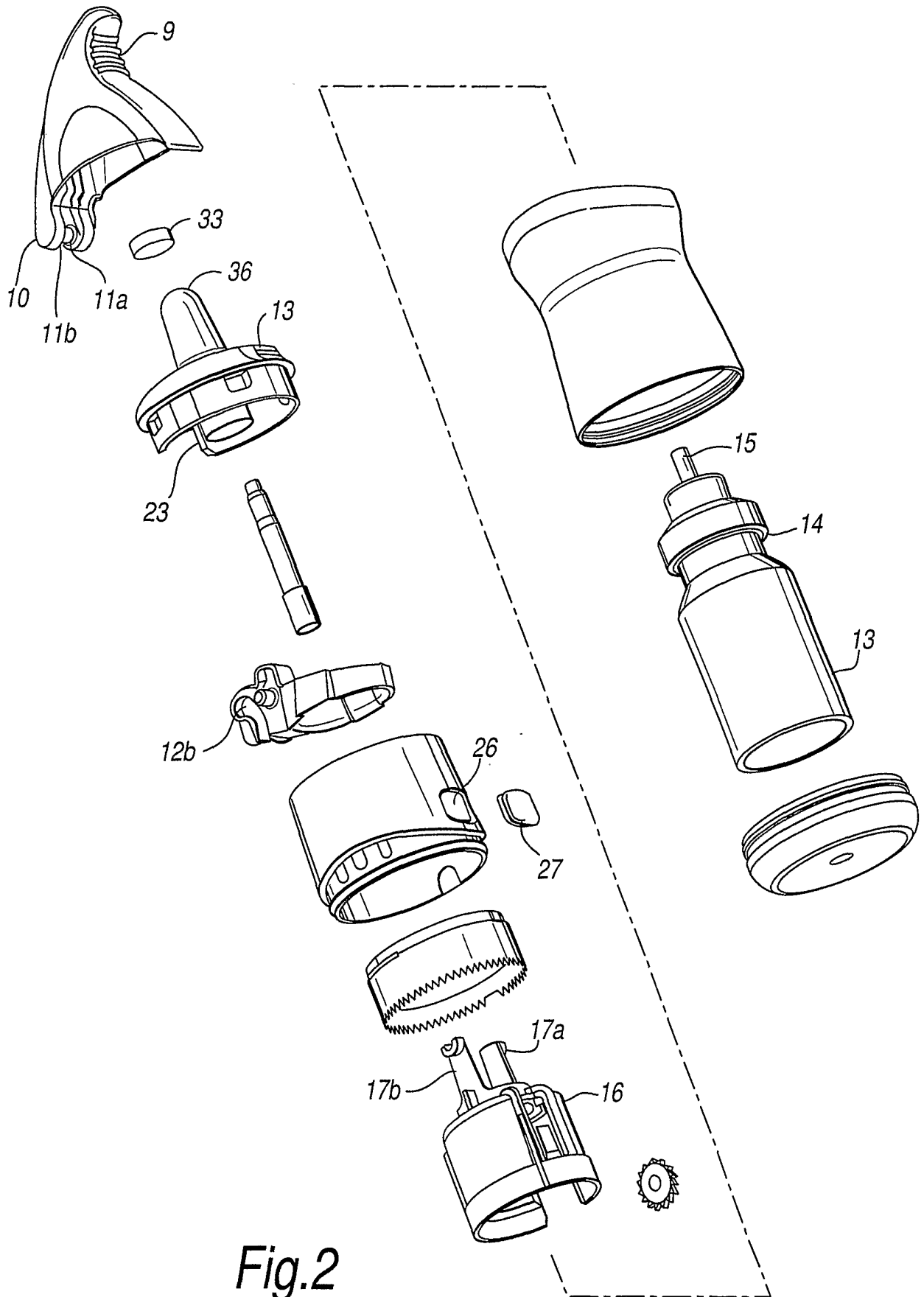

Fig.2

3/15

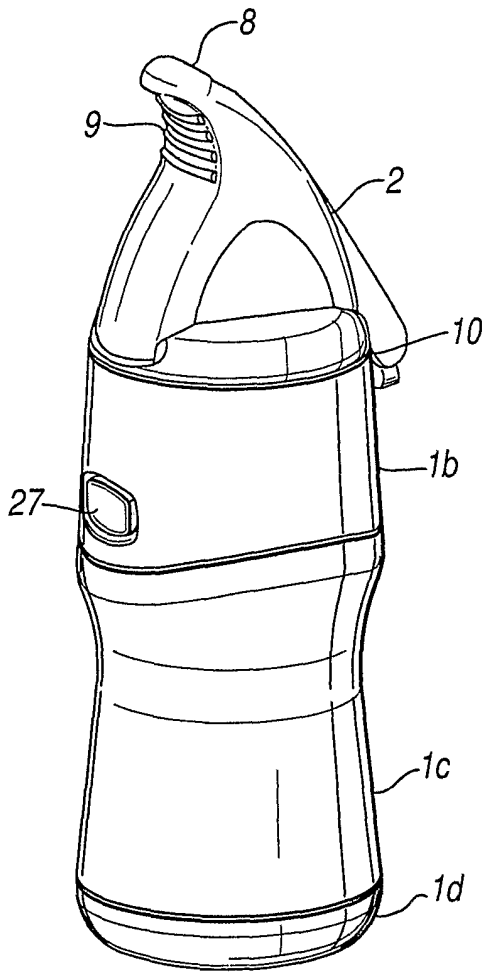

Fig.3

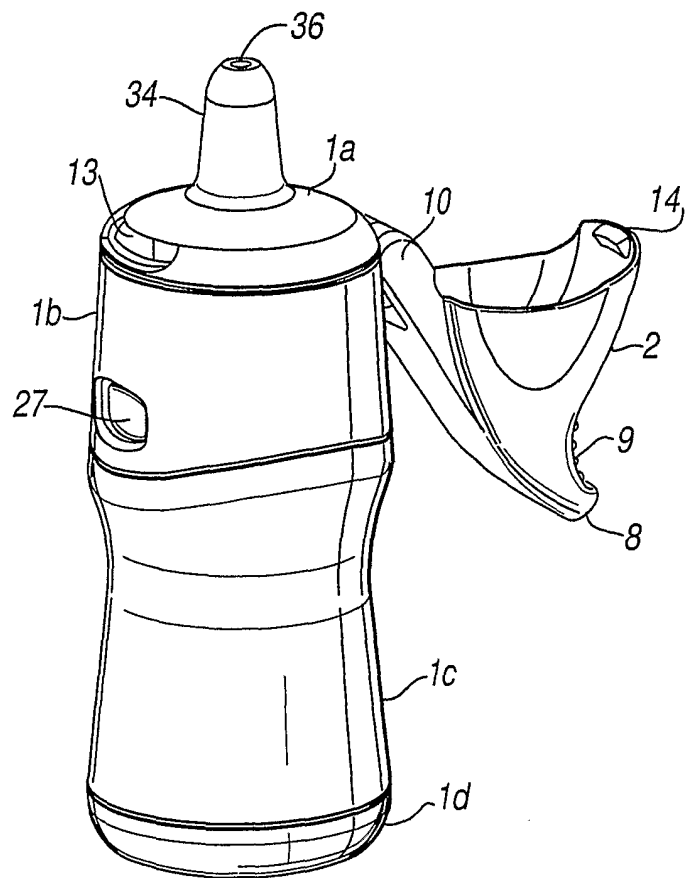

Fig.4

4/15

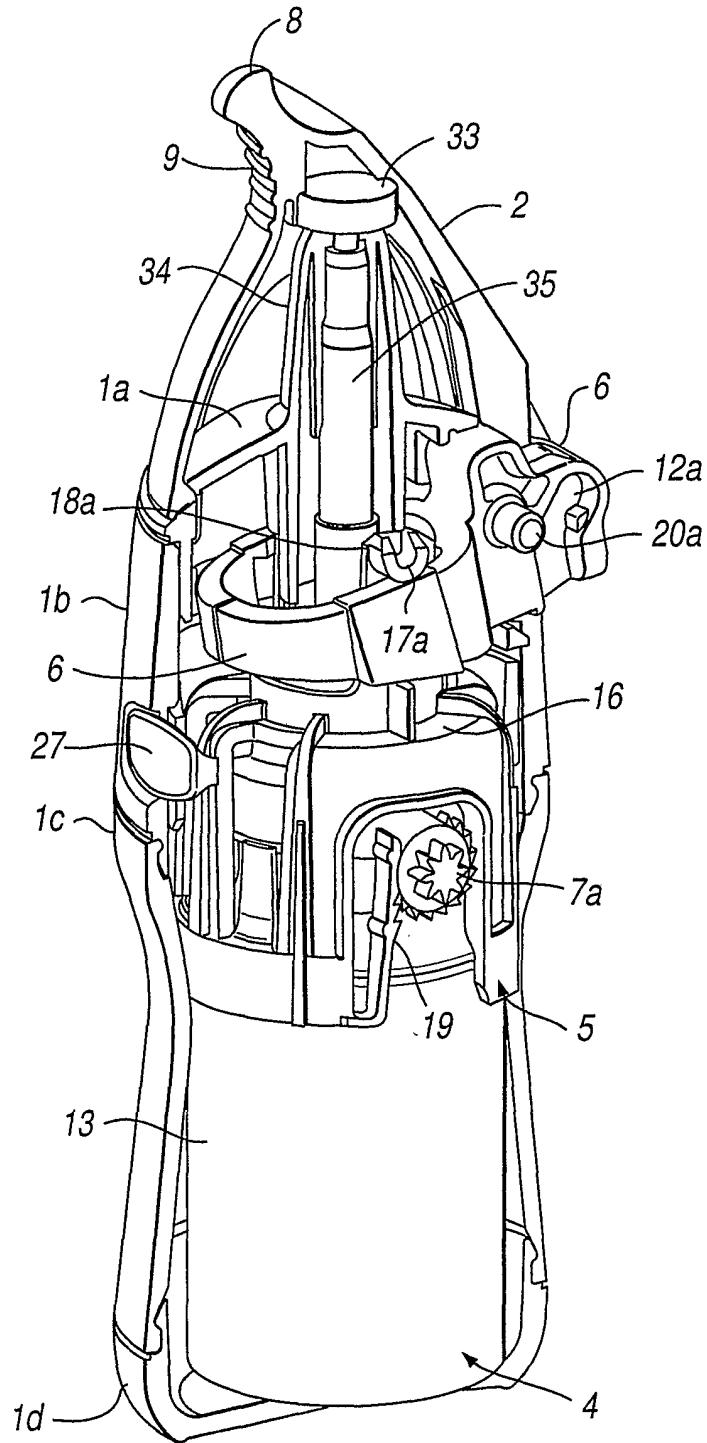

Fig.5

5/15

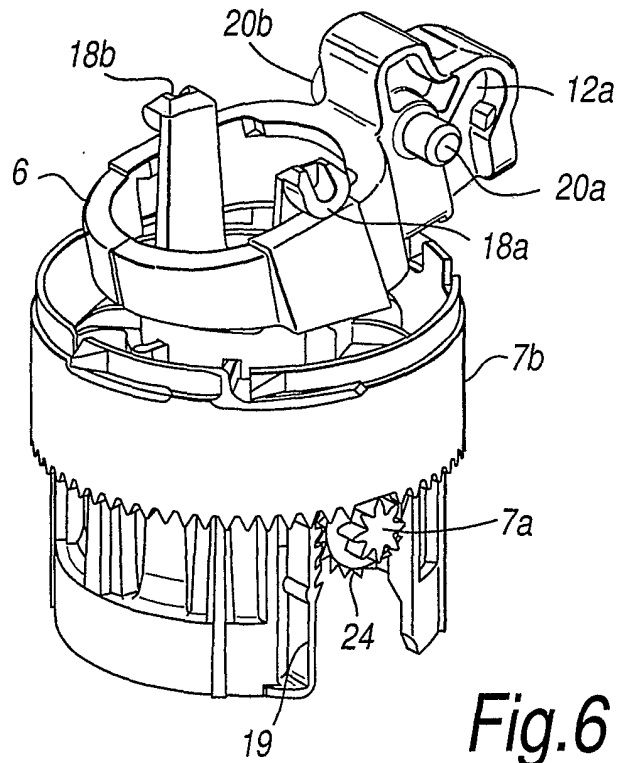

Fig. 6

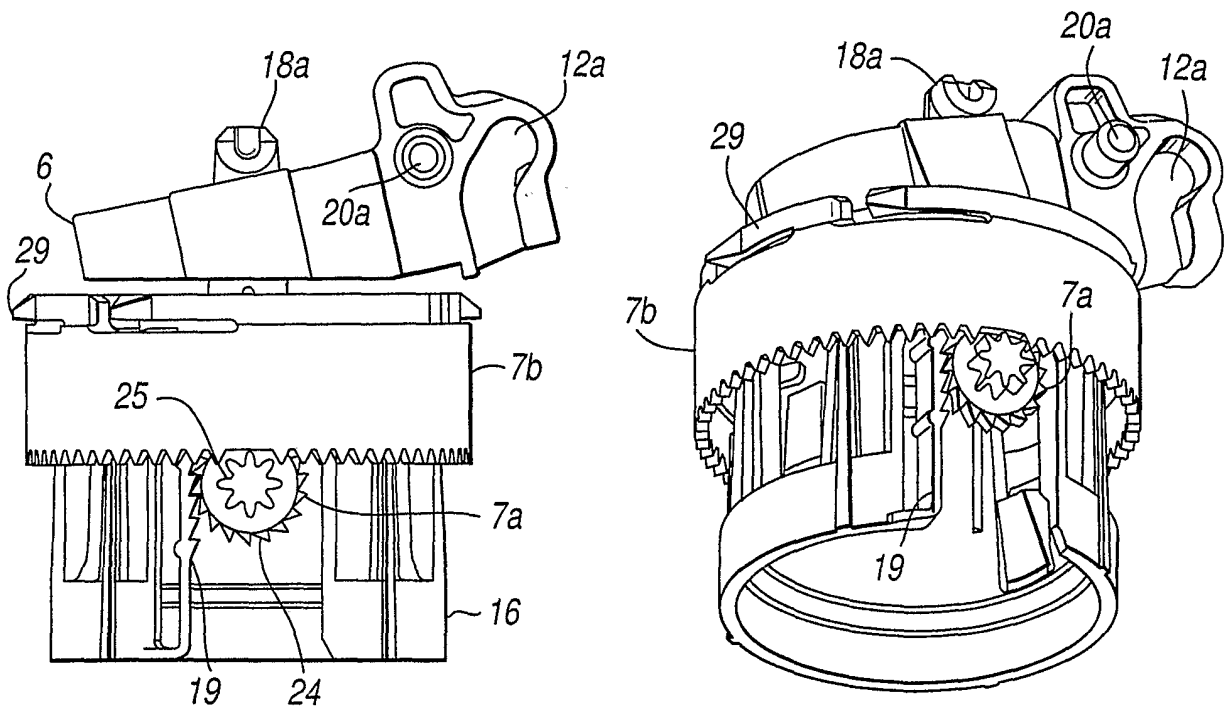

Fig. 7

Fig. 8

6/15

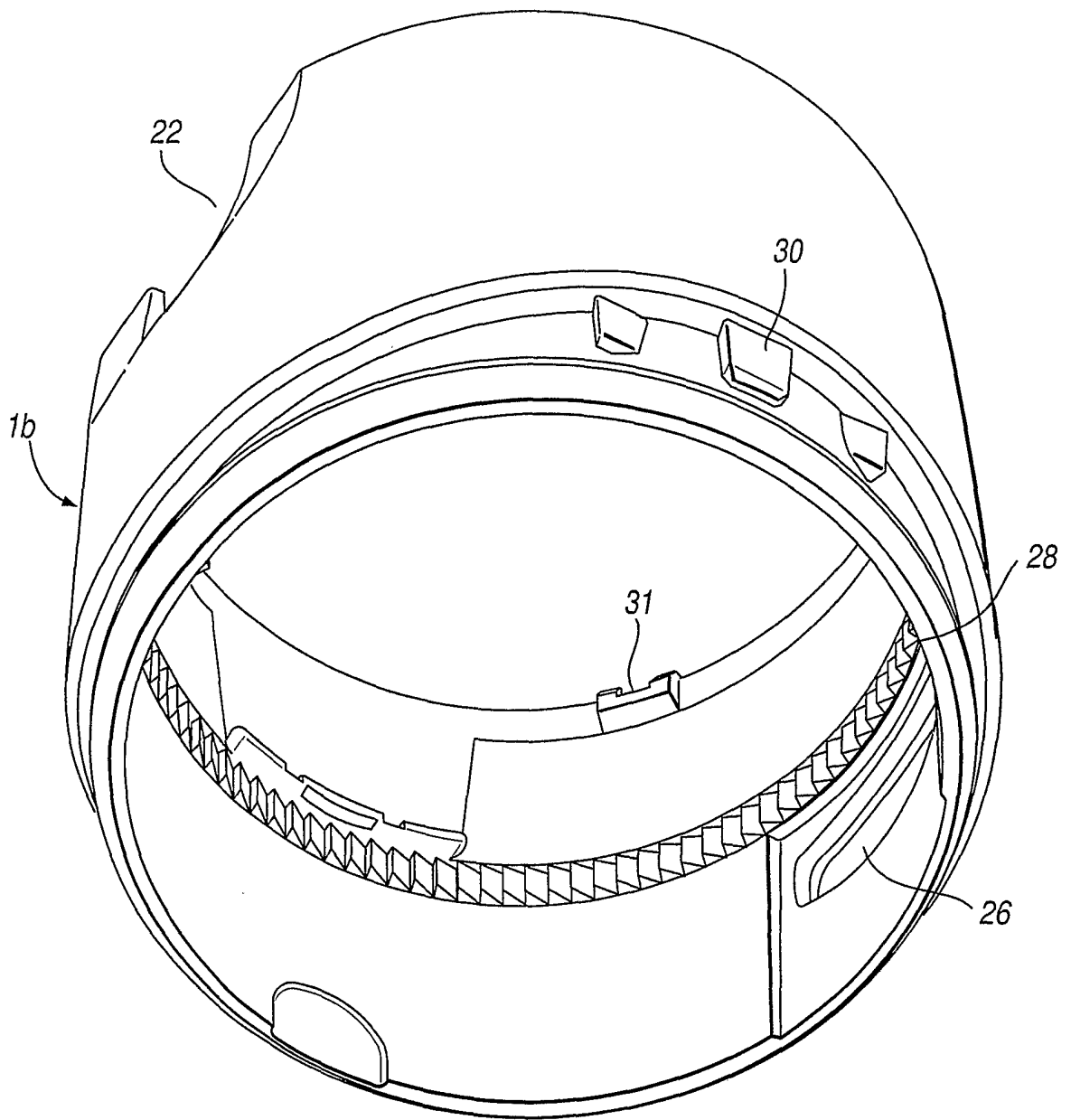

Fig.9

7/15

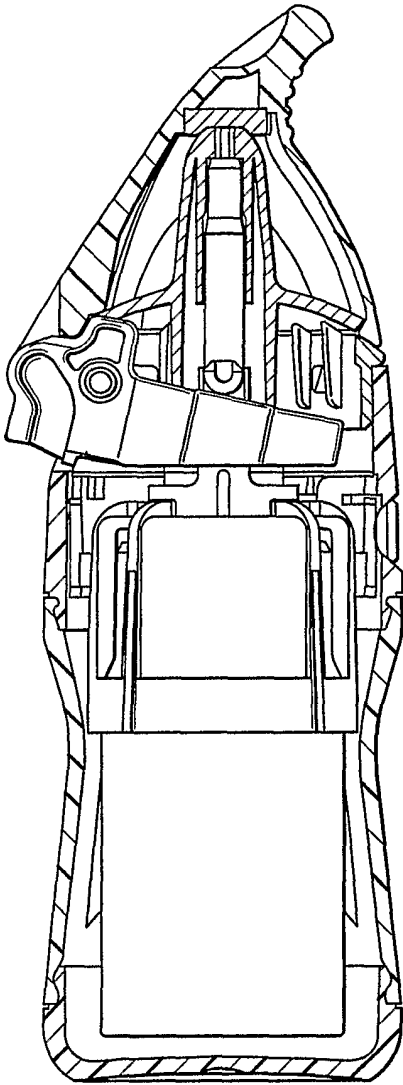

Fig. 10a

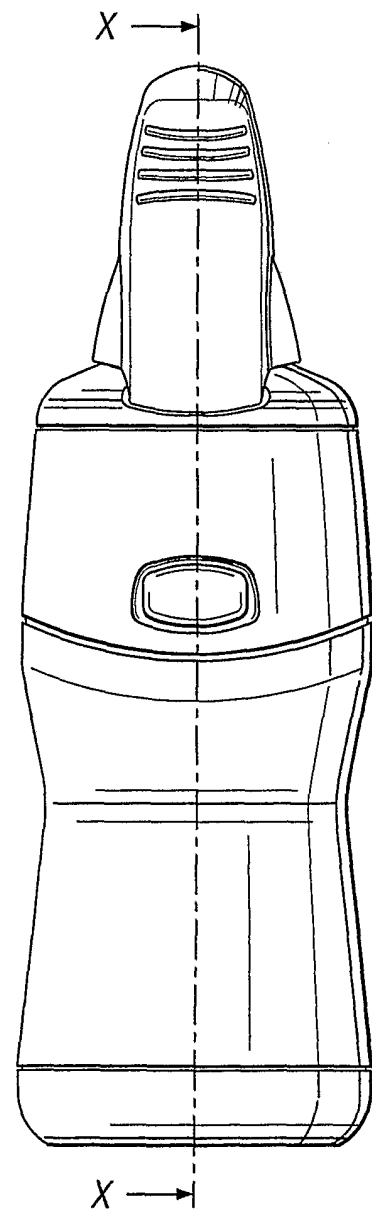

Fig. 10b

8/15

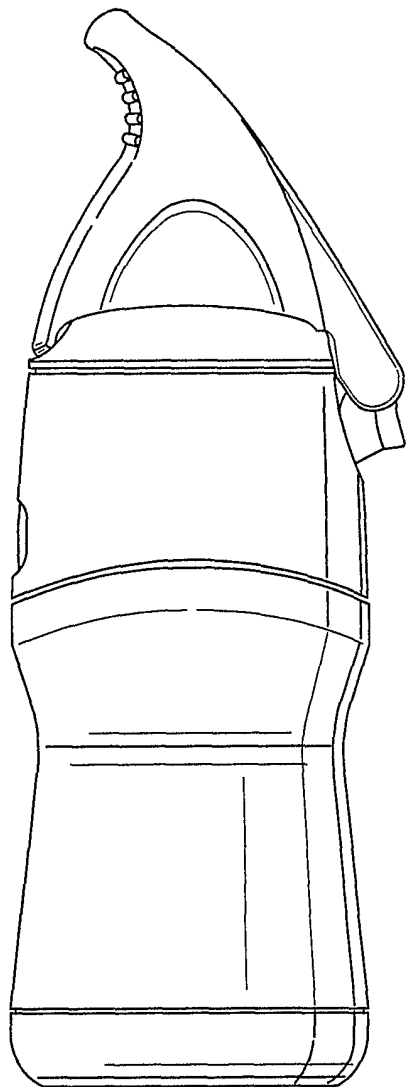

Fig. 10c

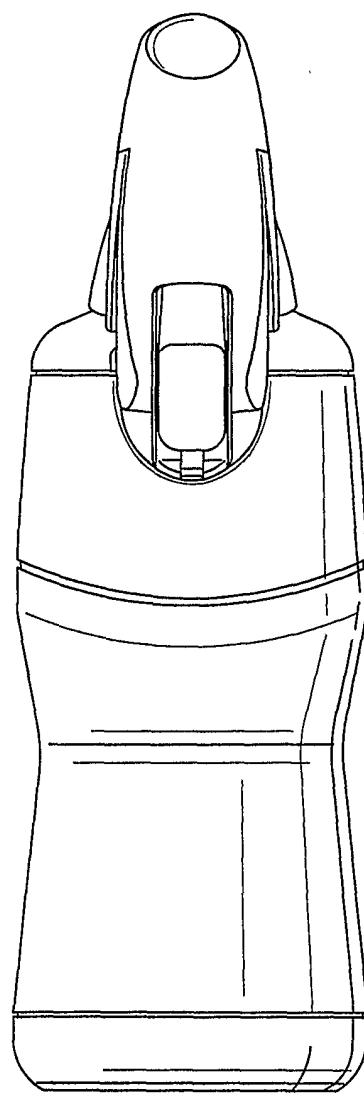

Fig. 10d

9/15

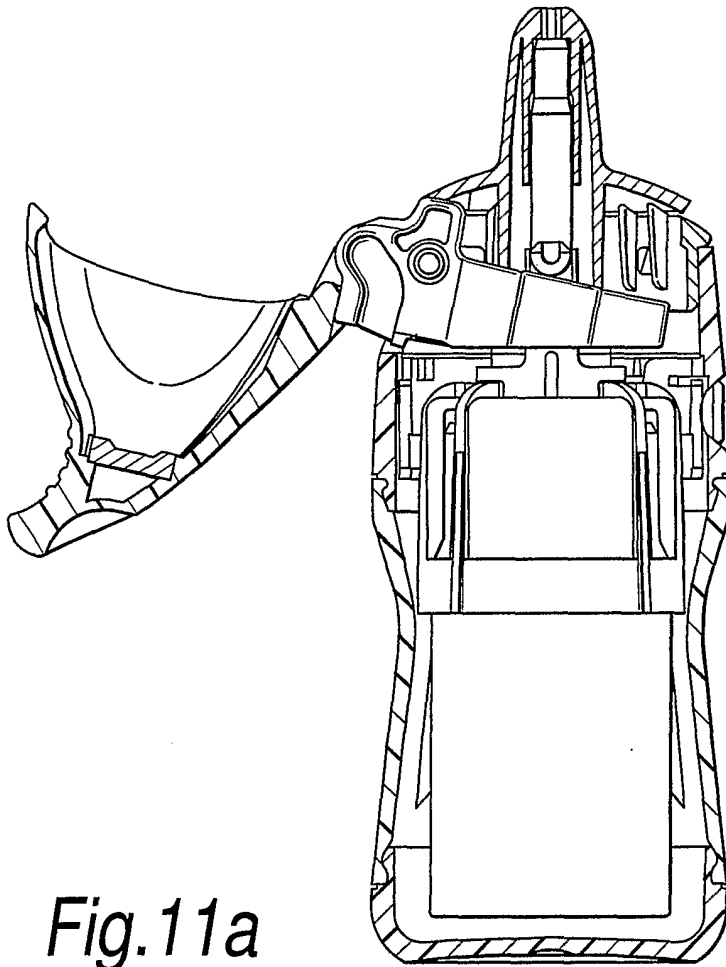

Fig. 11a

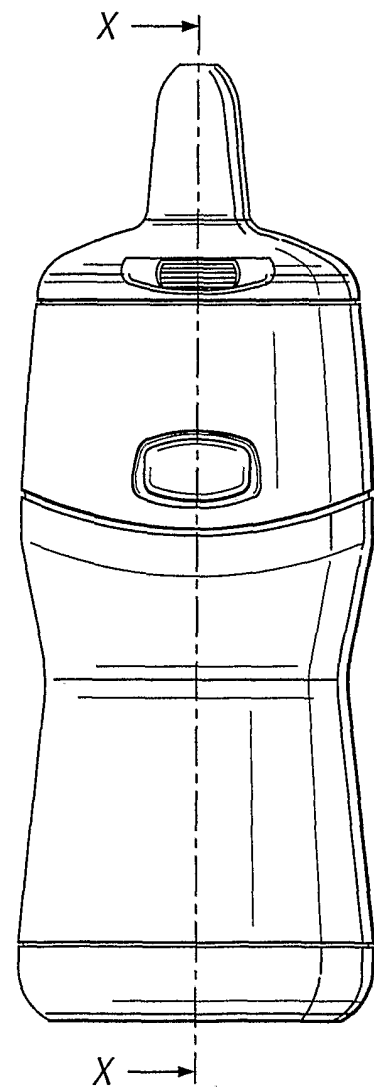

Fig. 11b

10/15

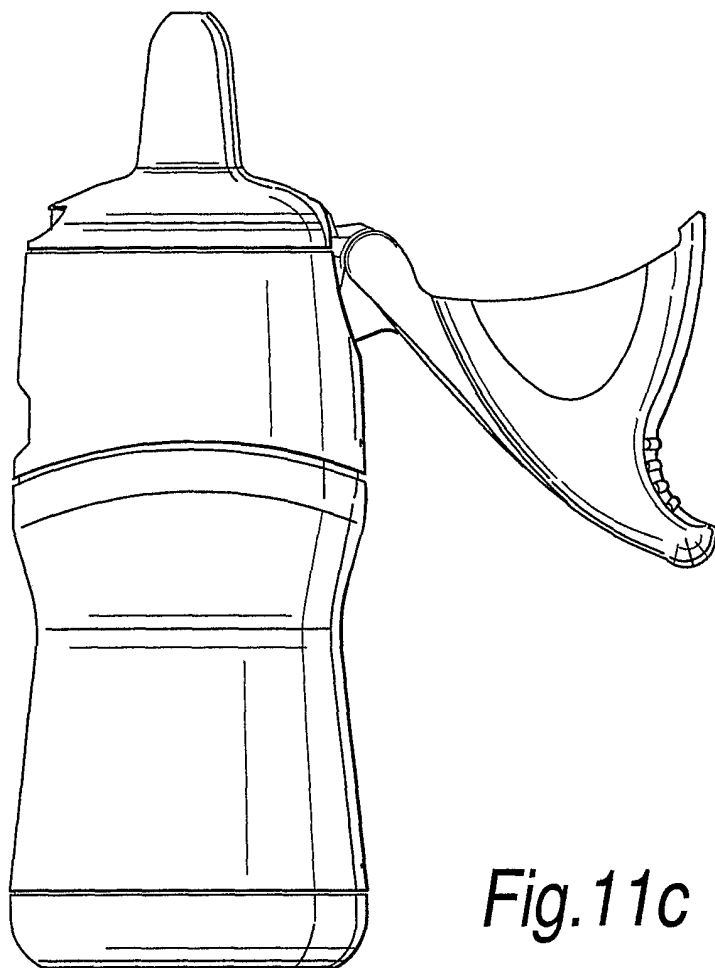

Fig. 11c

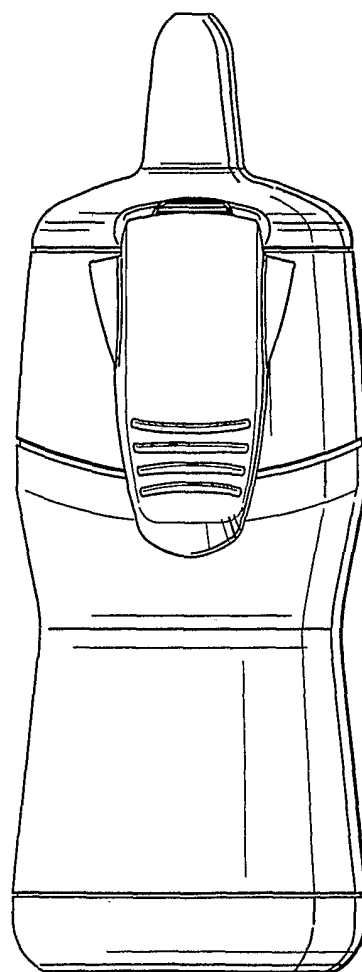

Fig. 11d

11/15

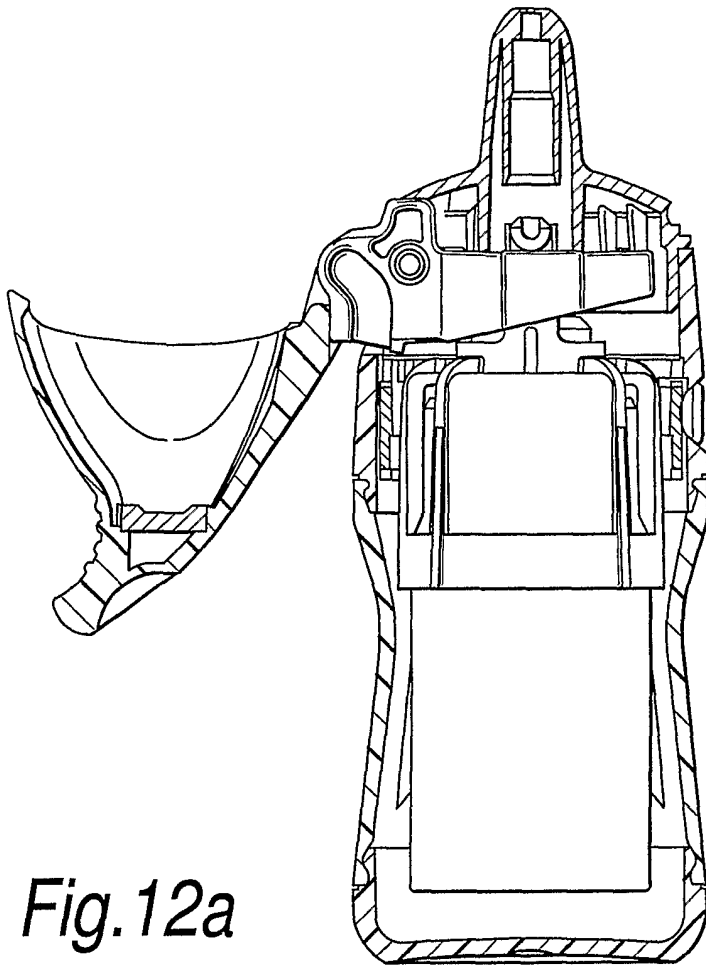

Fig. 12a

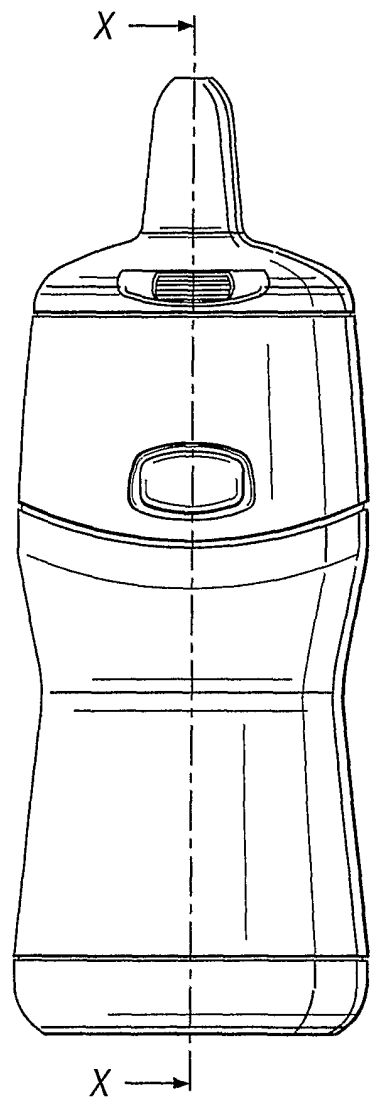

Fig. 12b

12/15

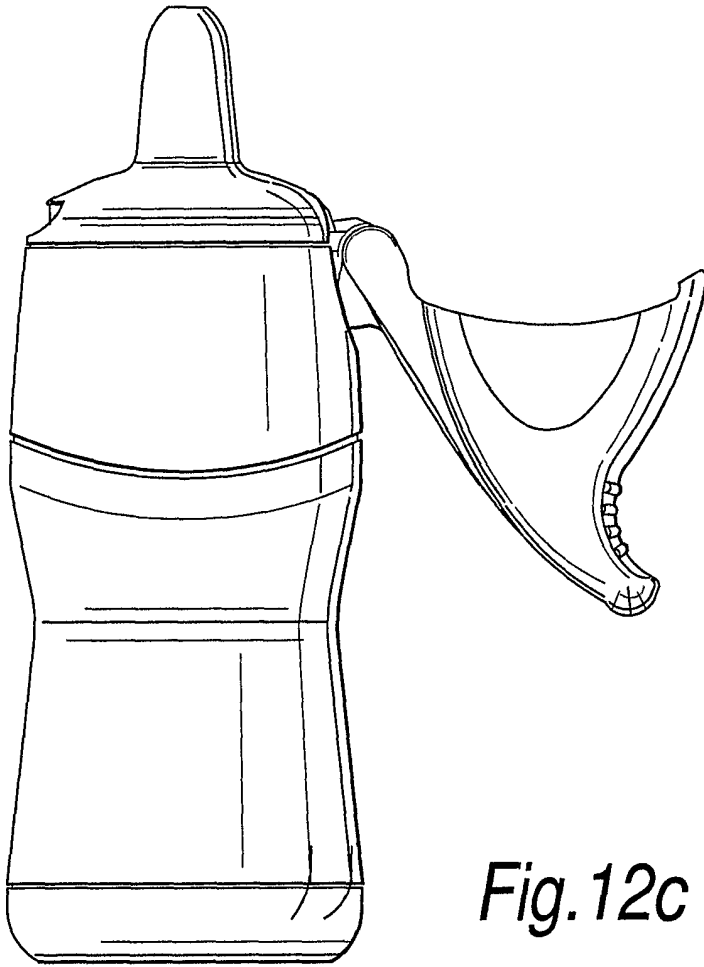

Fig. 12c

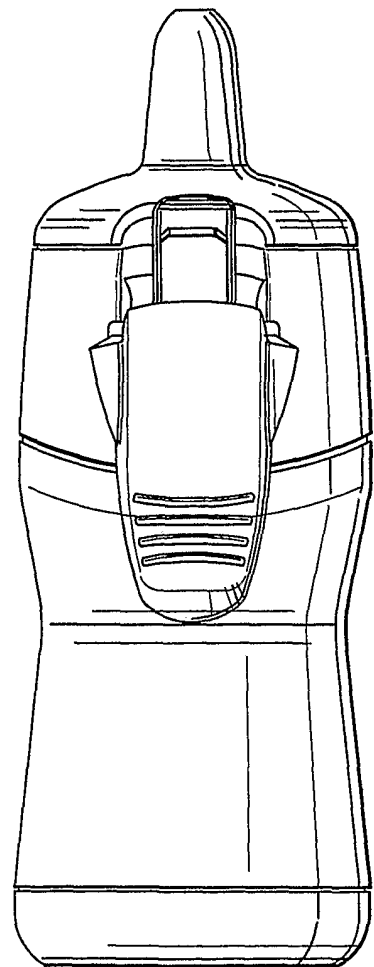

Fig. 12d

13/15

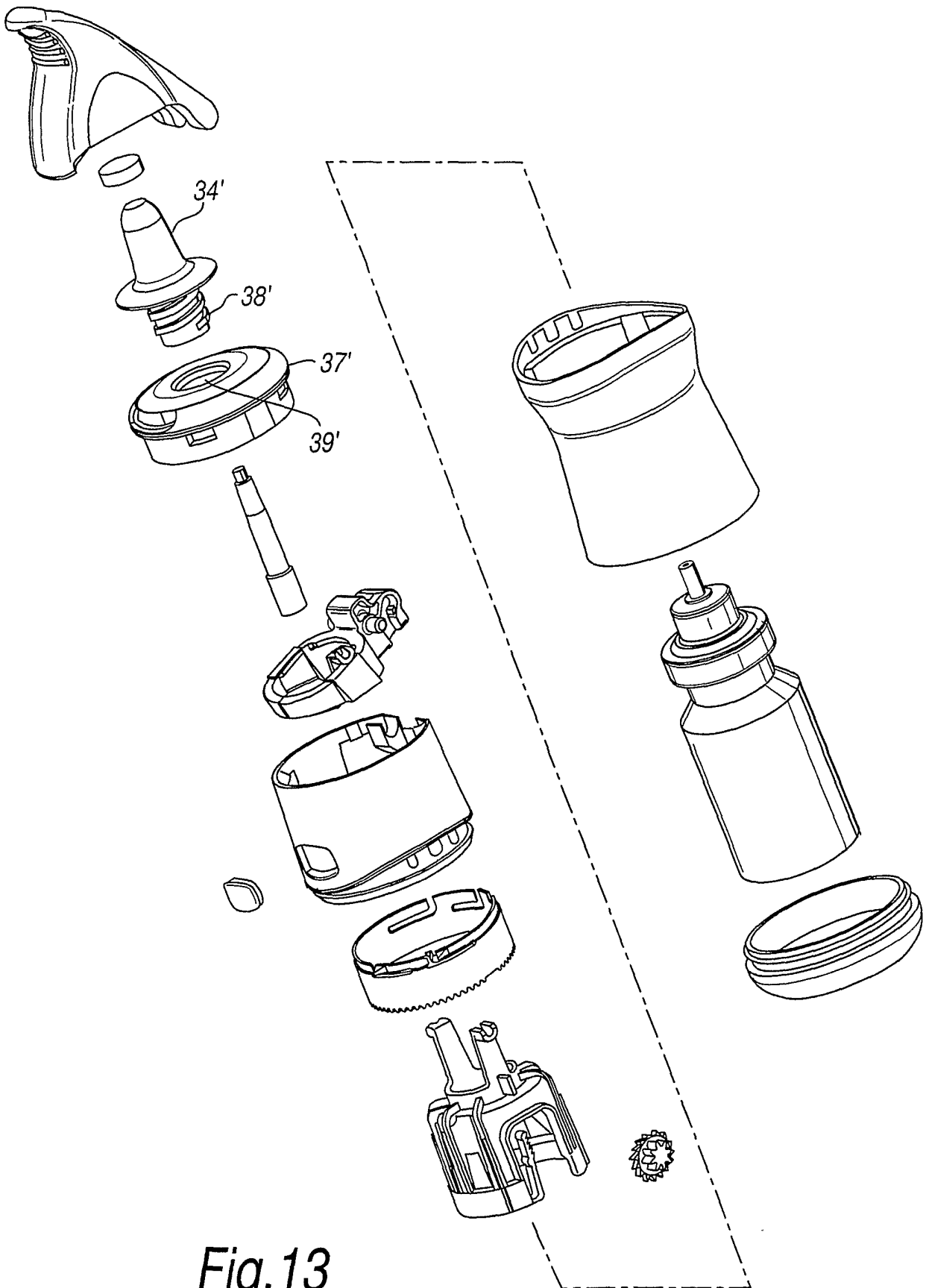

Fig.13

14/15

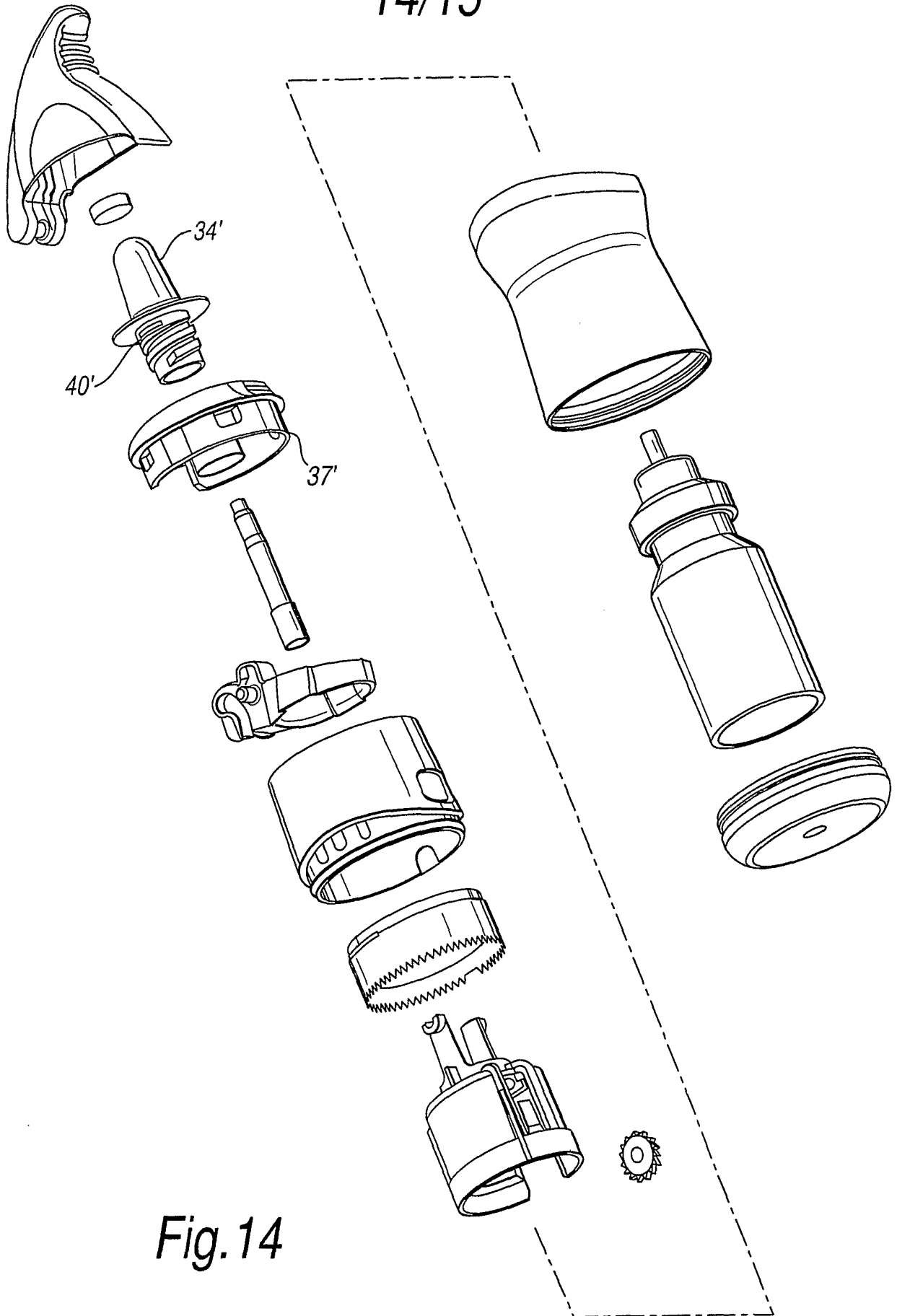

Fig. 14

15/15

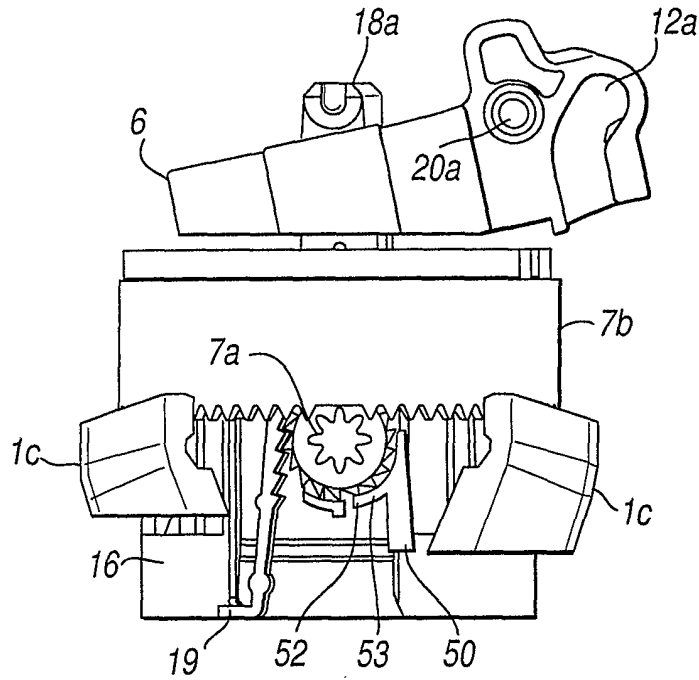

Fig. 15

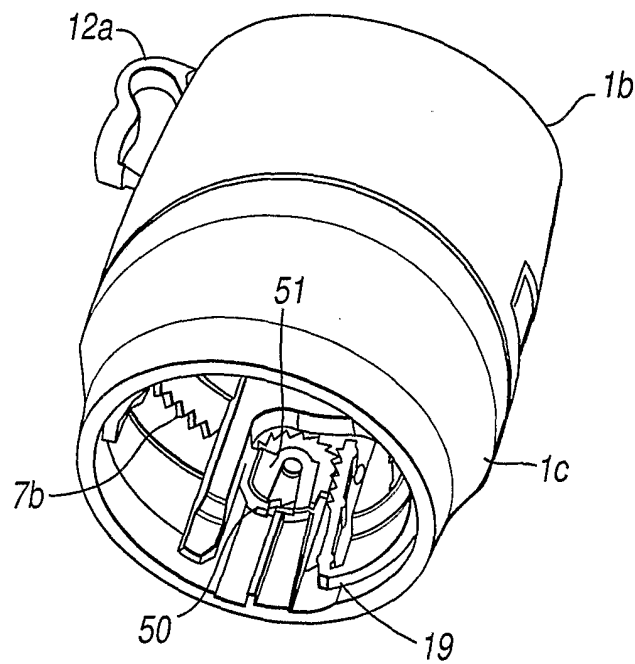

Fig. 16

INTERNATIONAL SEARCH REPORT

International Application No

PCT/GB 01/05695

A. CLASSIFICATION OF SUBJECT MATTER
IPC 7 B05B11/00

According to International Patent Classification (IPC) or to both national classification and IPC

B. FIELDS SEARCHED

Minimum documentation searched (classification system followed by classification symbols)

IPC 7 B05B A61M

Documentation searched other than minimum documentation to the extent that such documents are included in the fields searched

Electronic data base consulted during the international search (name of data base and, where practical, search terms used)

EPO-Internal

C. DOCUMENTS CONSIDERED TO BE RELEVANT

Category °	Citation of document, with indication, where appropriate, of the relevant passages	Relevant to claim No.
P,X	WO 01 03851 A (PATON MICHAEL ;JENNINGS DOUGLAS (GB); MACMICHAEL BRUCE (GB); HELGE) 18 January 2001 (2001-01-18) page 11, line 7 - line 13 ---	1,10,19
X	FR 2 750 406 A (VALOIS) 2 January 1998 (1998-01-02) claims 3,5,8,9,15 ---	15-18
X	FR 2 791 955 A (VALOIS SA) 13 October 2000 (2000-10-13) abstract page 4, line 15 - line 21 ---	15,17,18
A	US 6 082 358 A (SCARROTT PETER MYKOLA ET AL) 4 July 2000 (2000-07-04) abstract -----	1-5



Further documents are listed in the continuation of box C.



Patent family members are listed in annex.

° Special categories of cited documents :

- *A* document defining the general state of the art which is not considered to be of particular relevance
- *E* earlier document but published on or after the international filing date
- *L* document which may throw doubts on priority claim(s) or which is cited to establish the publication date of another citation or other special reason (as specified)
- *O* document referring to an oral disclosure, use, exhibition or other means
- *P* document published prior to the international filing date but later than the priority date claimed

- *T* later document published after the international filing date or priority date and not in conflict with the application but cited to understand the principle or theory underlying the invention
- *X* document of particular relevance; the claimed invention cannot be considered novel or cannot be considered to involve an inventive step when the document is taken alone
- *Y* document of particular relevance; the claimed invention cannot be considered to involve an inventive step when the document is combined with one or more other such documents, such combination being obvious to a person skilled in the art.
- * & * document member of the same patent family

Date of the actual completion of the international search

5 June 2002

Date of mailing of the international search report

10.06.2002

Name and mailing address of the ISA

European Patent Office, P.B. 5818 Patentlaan 2
NL - 2280 HV Rijswijk
Tel. (+31-70) 340-2040, Tx. 31 651 epo nl,
Fax: (+31-70) 340-3016

Authorized officer

Juguet, J

INTERNATIONAL SEARCH REPORT

International application No.
PCT/GB 01/05695

Box I Observations where certain claims were found unsearchable (Continuation of item 1 of first sheet)

This International Search Report has not been established in respect of certain claims under Article 17(2)(a) for the following reasons:

1. Claims Nos.:
because they relate to subject matter not required to be searched by this Authority, namely:

2. Claims Nos.:
because they relate to parts of the International Application that do not comply with the prescribed requirements to such an extent that no meaningful International Search can be carried out, specifically:

3. Claims Nos.:
because they are dependent claims and are not drafted in accordance with the second and third sentences of Rule 6.4(a).

Box II Observations where unity of invention is lacking (Continuation of item 2 of first sheet)

This International Searching Authority found multiple inventions in this international application, as follows:

see additional sheet

1. As all required additional search fees were timely paid by the applicant, this International Search Report covers all searchable claims.

2. As all searchable claims could be searched without effort justifying an additional fee, this Authority did not invite payment of any additional fee.

3. As only some of the required additional search fees were timely paid by the applicant, this International Search Report covers only those claims for which fees were paid, specifically claims Nos.:

4. No required additional search fees were timely paid by the applicant. Consequently, this International Search Report is restricted to the invention first mentioned in the claims; it is covered by claims Nos.:

Remark on Protest

- The additional search fees were accompanied by the applicant's protest.
- No protest accompanied the payment of additional search fees.

FURTHER INFORMATION CONTINUED FROM PCT/ISA/ 210

This International Searching Authority found multiple (groups of) inventions in this international application, as follows:

1. Claims: 1-14 19

delivery device with a dose counting mechanism

2. Claims: 15-18

delivery device comprising a cover member

INTERNATIONAL SEARCH REPORT

Information on patent family members

International Application No

PCT/GB 01/05695

Patent document cited in search report	A	Publication date	Patent family member(s)	Publication date
WO 0103851	A	18-01-2001	AU 6194400	30-01-2001
			BR 0012421	02-04-2002
			EP 1198299	24-04-2002
			NO 20020150	07-03-2002
			WO 0103851	18-01-2001
FR 2750406	A	02-01-1998	FR 2750406	02-01-1998
			DE 69701745	25-05-2000
			DE 69701745	28-12-2000
			EP 0929473	21-07-1999
			WO 9800354	08-01-1998
FR 2791955	A	13-10-2000	FR 2791955	13-10-2000
			CN 1346325	24-04-2002
			EP 1169241	09-01-2002
			WO 0061454	19-10-2000
US 6082358	A	04-07-2000	AU 3774699	23-11-1999
			CA 2331179	11-11-1999
			CN 1310635	29-08-2001
			EP 1131248	12-09-2001
			WO 9957019	11-11-1999
			US 6328037	11-12-2001