



US00D445148S

(12) **United States Design Patent** (10) **Patent No.:** **US D445,148 S**
McIntosh (45) **Date of Patent:** **** Jul. 17, 2001**

(54) **TOY CONSTRUCTION BLOCK**

(76) Inventor: **Eric G. McIntosh**, #207 - 1066 E. 8th Avenue, Vancouver, British Columbia (CA), V5T 1T9

(**) Term: **14 Years**

(21) Appl. No.: **29/088,588**

(22) Filed: **May 28, 1998**

(51) **LOC (7) Cl.** **21-01**

(52) **U.S. Cl.** **D21/500**

(58) **Field of Search** D21/483-505;
D25/113-118; 446/85, 93-96, 102-107,
110-113, 120-122, 124, 128, 127; 52/592.1,
592.2, 592.4

(56) **References Cited**

U.S. PATENT DOCUMENTS

D. 378,838 * 4/1997 Olen et al. D21/486
D. 387,431 12/1997 Tremblay .

(List continued on next page.)

FOREIGN PATENT DOCUMENTS

81482 8/1997 (CA) .
81483 8/1997 (CA) .
81484 8/1997 (CA) .
81485 8/1997 (CA) .

Primary Examiner—Raphael Barkai
(74) *Attorney, Agent, or Firm*—Oyen Wiggs Green and Mutala

(57) **CLAIM**

The ornamental design for a toy construction block, as shown and described.

DESCRIPTION

FIG. 1 is a top perspective view of the full-length toy construction block;

FIG. 2 is a top perspective view of the block from the diagonally opposite corner from the view of FIG. 1;

FIG. 3 is a bottom perspective view of the block;

FIG. 4 is a bottom perspective view of the block from the diagonally opposite corner from the view of FIG. 3;

FIG. 5 is a top plan view of the block;

FIG. 6 is a bottom plan view of the block;

FIG. 7 is a front side view of the block;

FIG. 8 is a rear side view of the block;

FIG. 9 is a left side view of the block;

FIG. 10 is a right side view of the block;

FIG. 11 is a top perspective view of a modified embodiment of the design shown in FIGS. 1-10.

FIG. 12 is a top perspective view of the half-length block from the diagonally opposite corner from the view of FIG. 11;

FIG. 13 is a bottom perspective view of the half-length block;

FIG. 14 is a bottom perspective view of the half-length block from the diagonally opposite corner from the view of FIG. 13;

FIG. 15 is a top plan view of the half-length block;

FIG. 16 is a bottom plan view of the half-length block;

FIG. 17 is a front side view of the half-length block;

FIG. 18 is a rear side view of the half-length block;

FIG. 19 is a left side view of the half-length block; and,

FIG. 20 is a right side view of the half-length block.

1 Claim, 10 Drawing Sheets

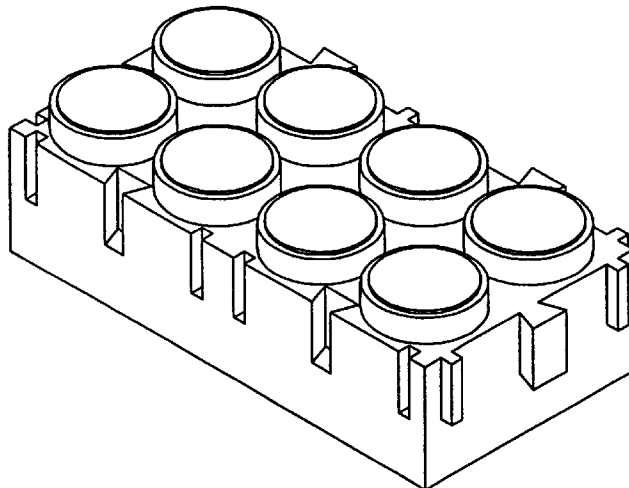

US D445,148 S

Page 2

U.S. PATENT DOCUMENTS						
			3,464,624	*	9/1969	Christiansen 446/128
460,177	9/1891	Cook .	3,558,138		1/1971	Lemelson .
868,838	10/1907	Brewington .	3,570,170	*	3/1971	Kishi 446/128
964,160	7/1910	Hammett .	4,035,947		7/1977	Burge .
1,130,324	3/1915	Owen .	4,516,364		5/1985	Heider .
1,163,851	* 12/1915	Pringle D21/486	4,552,541	*	11/1985	Bolli 446/128
1,531,542	3/1925	Cogshall .	4,744,780	*	5/1988	Volpe 446/128
1,984,393	* 12/1934	Brown 52/592.1	5,069,647		12/1991	Zuviria .
2,472,363	6/1949	Blackinton .	5,365,714		11/1994	Potvin .
2,619,829	12/1952	Tatum .	5,527,201	*	6/1996	Maddock 446/104
2,800,743	7/1957	Meehan et al. .	5,653,621		8/1997	Yao .
3,005,282	10/1961	Christiansen .	5,707,271	*	1/1998	Kunz et al. 446/128
3,148,477	9/1964	Bjorn et al. .				
3,305,982	2/1967	Steele .				

* cited by examiner

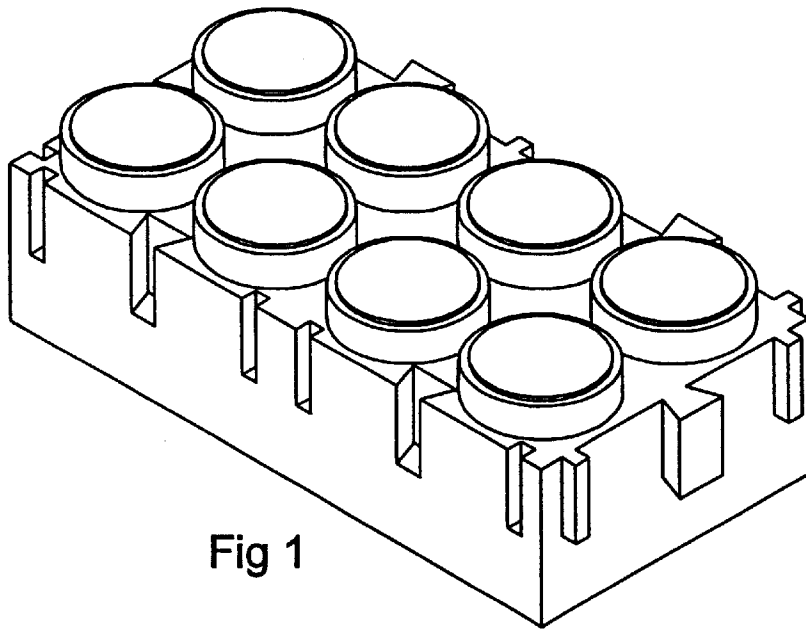

Fig 1

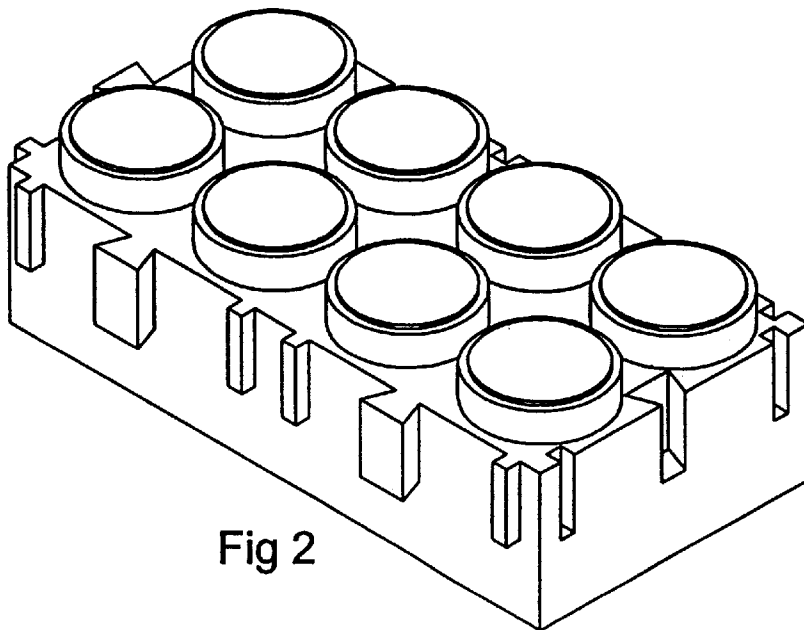

Fig 2

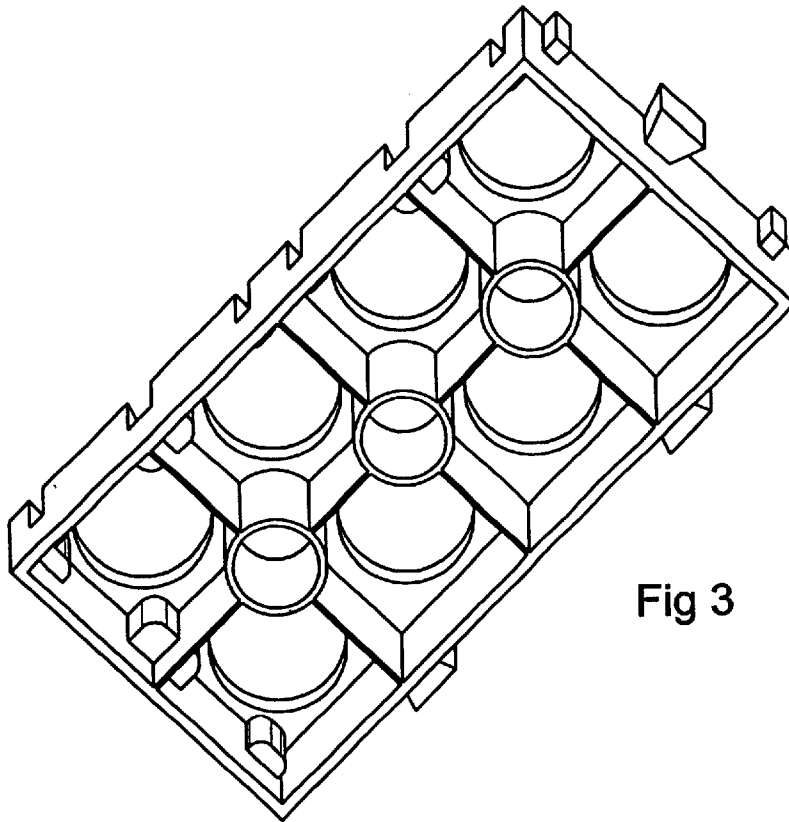

Fig 3

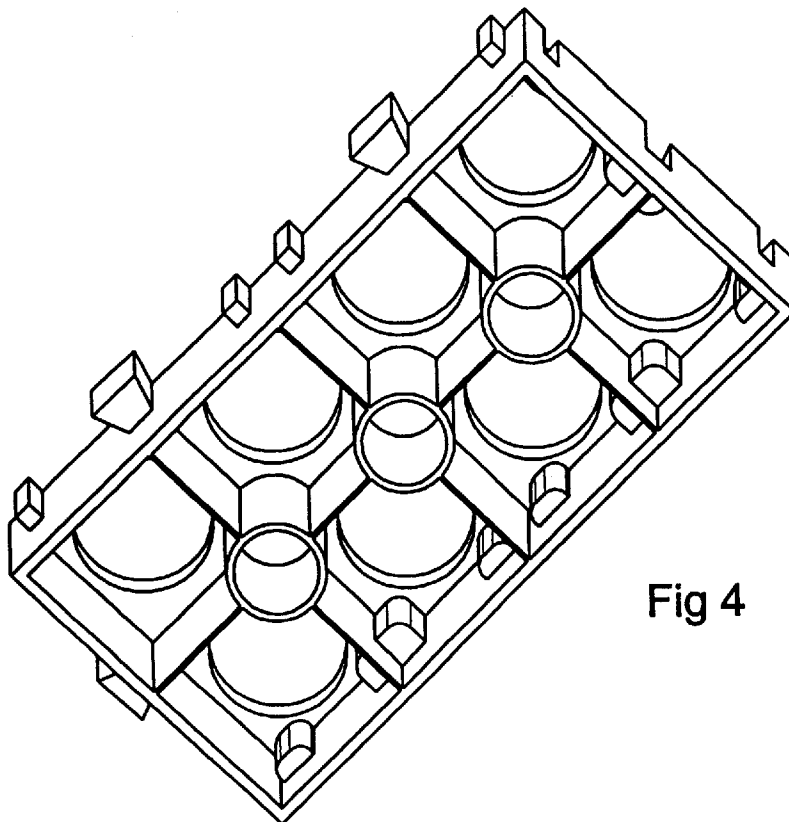

Fig 4

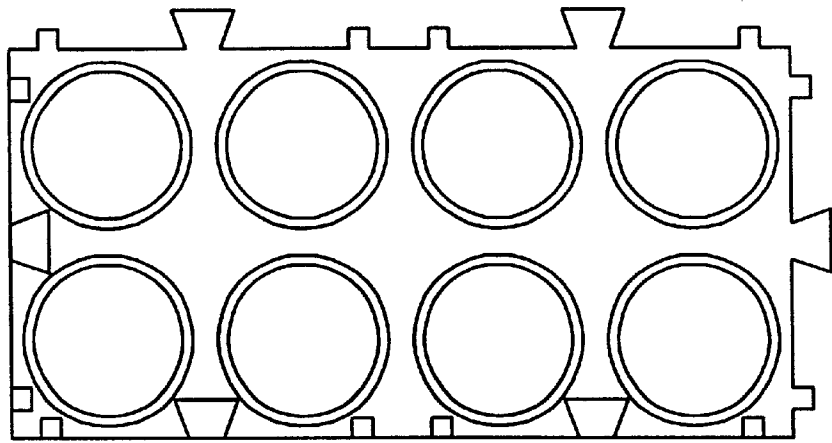

Fig 5

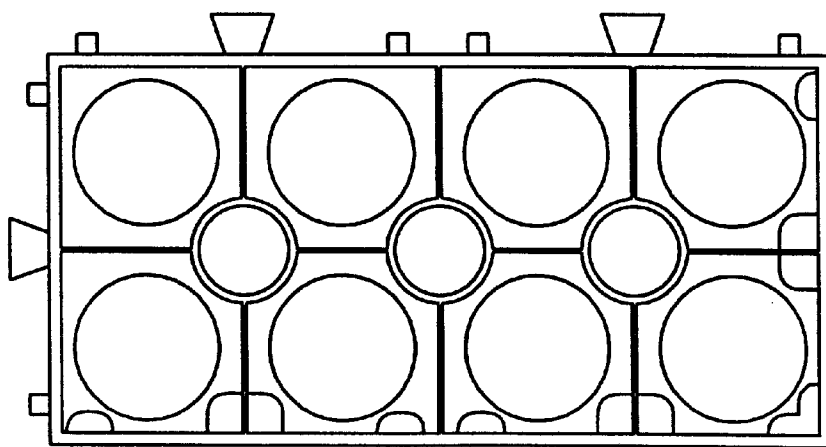

Fig 6

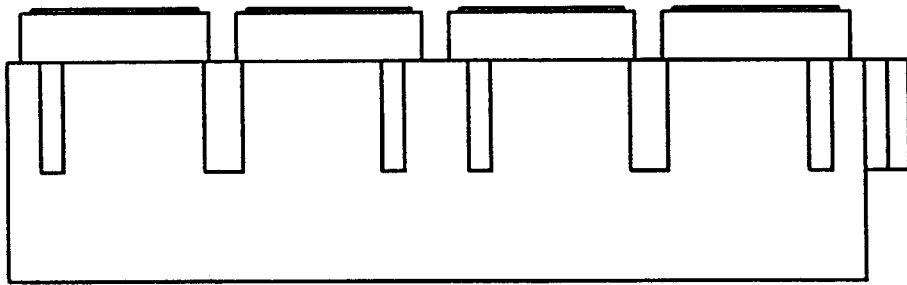

Fig 7

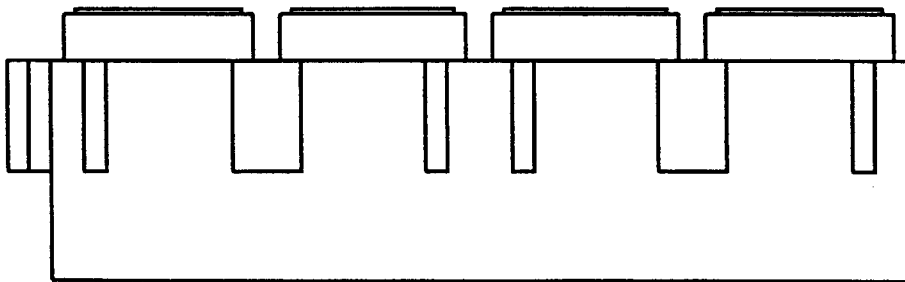

Fig 8

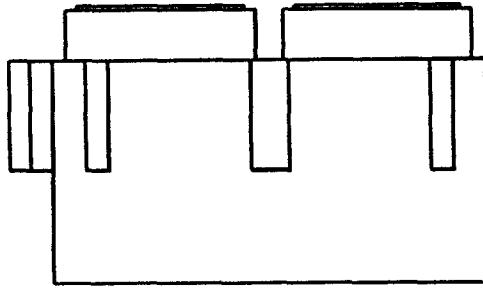

Fig 9

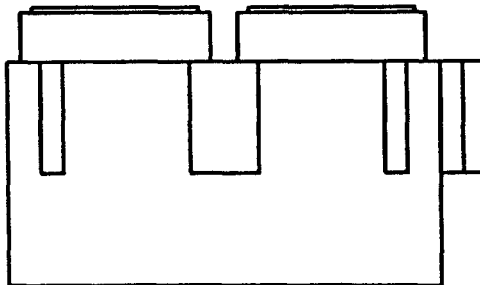

Fig 10

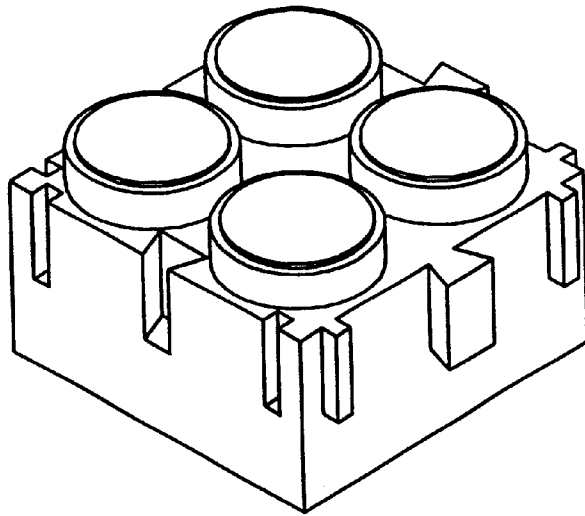

Fig 11

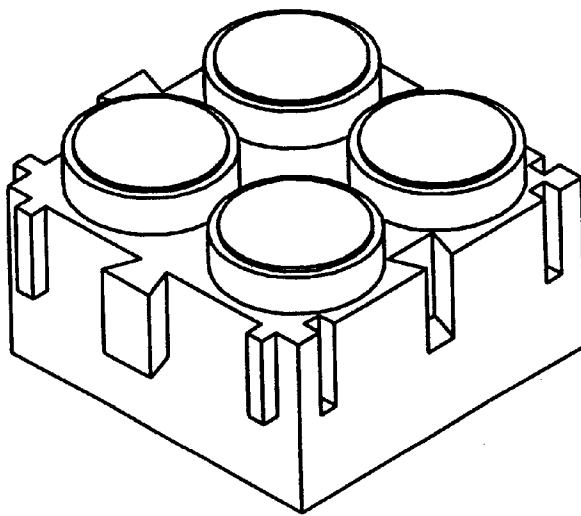

Fig 12

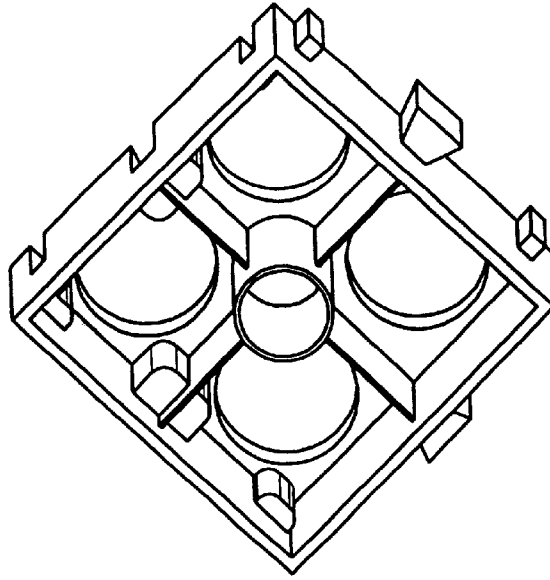

Fig 13

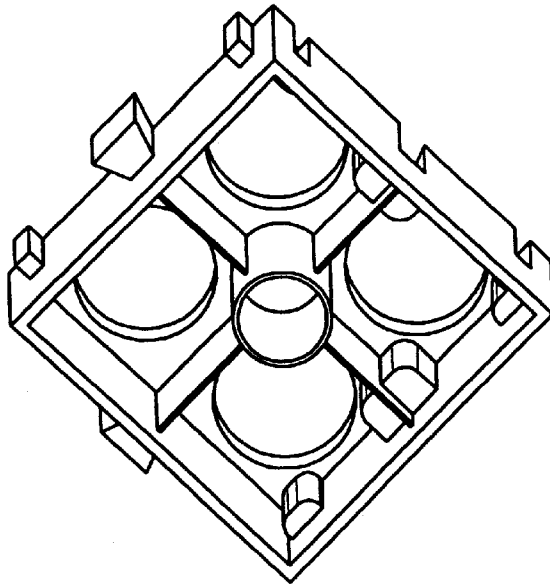

Fig 14

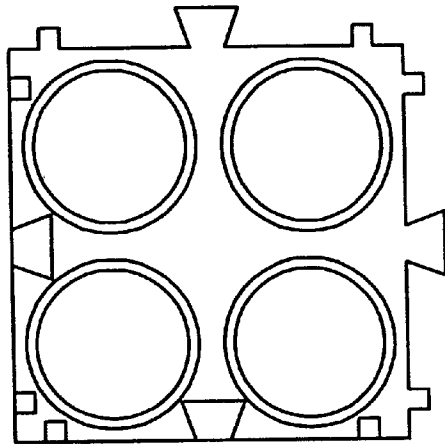

Fig 15

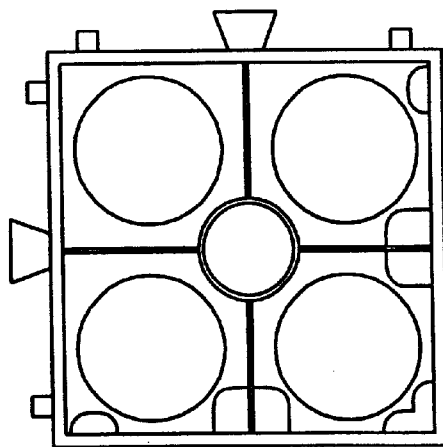

Fig 16

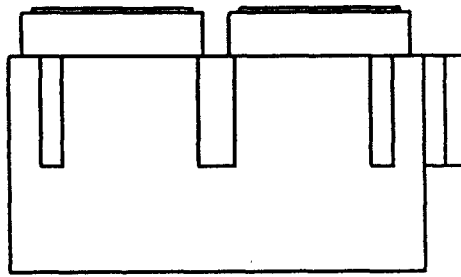

Fig 17

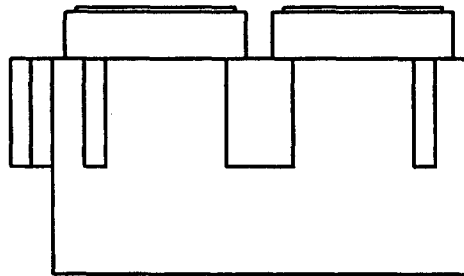

Fig 18

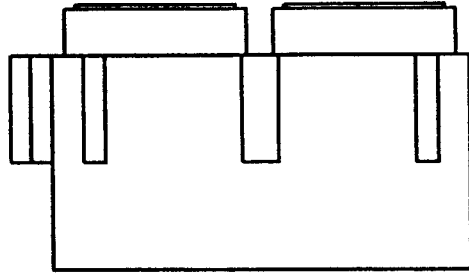

Fig 19

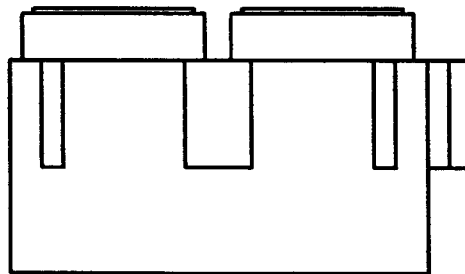

Fig 20