

W. S. KAUFFMAN.
CHEESE CABINET.

APPLICATION FILED OCT. 22, 1904.

2 SHEETS-SHEET 1.

Fig. 1.

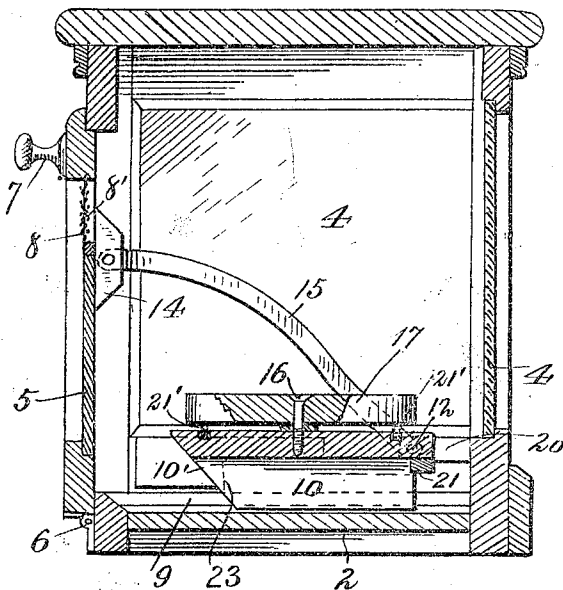
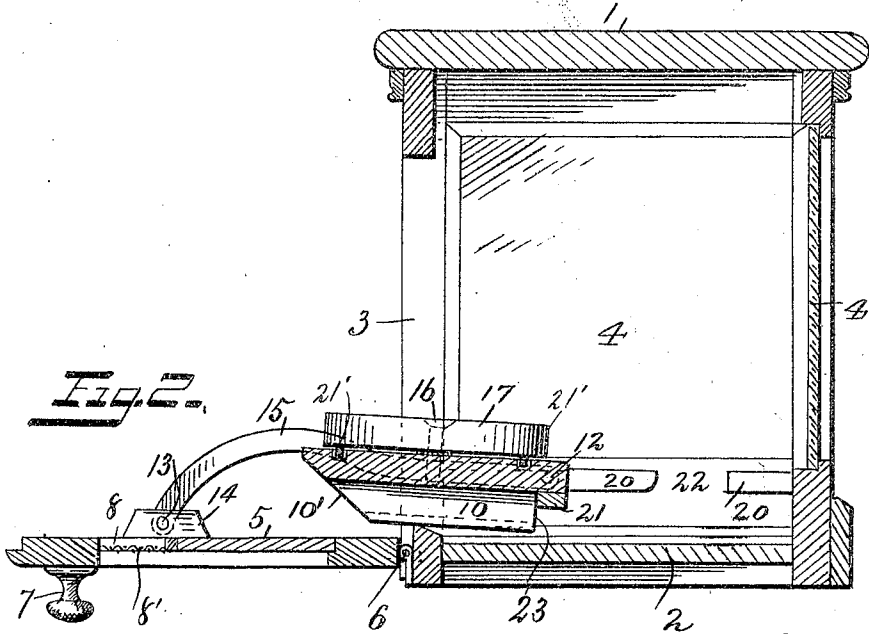

Fig. 2.



Inventor

William S. Kauffman

By *C. A. Braudenburg*

Attorney

Witnesses
Frank L. Curran
Wm. E. Boulter

W. S. KAUFFMAN.
CHEESE CABINET.

APPLICATION FILED OCT. 22, 1904.

2 SHEETS—SHEET 2.

Fig. 3.

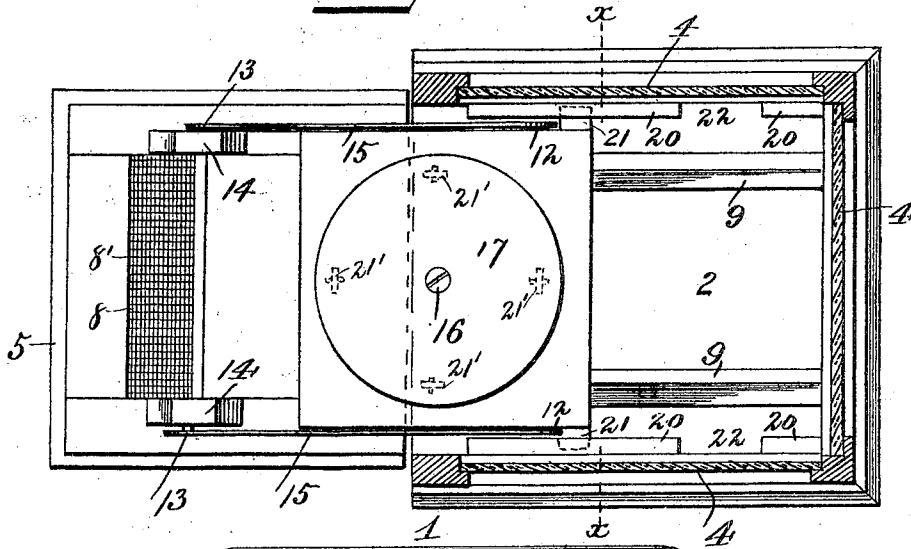

Fig. 4.

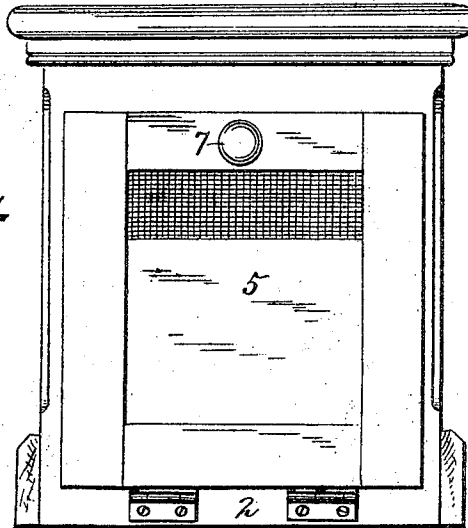
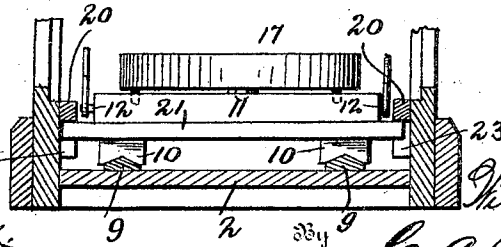

Fig. 5.



Witnesses
 Frank L. Orvand
 Wm B. Powell

Inventor

William S. Kauffman
 C. A. Brandenburg
 Attorney

UNITED STATES PATENT OFFICE.

WILLIAM S. KAUFFMAN, OF LEWISBURG, PENNSYLVANIA, ASSIGNOR TO
LEWISBURG NOVELTY COMPANY, LIMITED, OF LEWISBURG, PENN-
SYLVANIA, A LIMITED PARTNERSHIP.

CHEESE-CABINET.

No. 801,880.

Specification of Letters Patent.

Patented Oct. 17, 1905.

Application filed October 22, 1904. Serial No. 229,659.

To all whom it may concern:

Be it known that I, WILLIAM S. KAUFFMAN, a citizen of the United States, residing at Lewisburg, in the county of Union and State of Pennsylvania, have invented certain new and useful Improvements in Cheese-Cabinets, of which the following is a specification.

This invention relates to improvements in cheese-cabinets, the main objects in view being to produce a cabinet designed for use in retail stores and for containing cheeses; to construct the cabinet as will adapt the same to thoroughly protect the cheese from insects, dust, &c., and yet at the same time to expose the same to view of customers; to provide for an automatic withdrawal of the cheeses for the purpose of giving access thereto for cutting purchased quantities simply by the opening of the door; to provide for an automatic return of the cheeses upon the closing of the door; to provide for the ready cleaning of the bottom of the cabinet, and, finally, to improve the details of construction.

Other objects and advantages of the invention will hereinafter appear, and the novel features thereof will be particularly pointed out in the claims.

Referring to the drawings, Figure 1 is a vertical transverse sectional view of a cheese-cabinet embodying my invention, the door being closed. Fig. 2 is a similar view, the door being open. Fig. 3 is a horizontal sectional view of Fig. 2, taken on a line just above the revoluble disk. Fig. 4 is a front view of Fig. 1. Fig. 5 is a sectional view on line *xx* of Fig. 3, parts being broken away.

Similar numerals of reference indicate similar parts in all the figures of the drawings.

The cabinet is of the usual or conventional rectangular shape and comprises the top 1, bottom 2, front door-opening 3, and glass panels 4, through which latter the contents of the cabinet may be readily seen and examined by customers. The door-opening 3 is closed by a downwardly-opening door 5, hinged at its lower edge, as at 6, to the lower edge of the opening. This door may be provided with any suitable operating-knob 7 and may have a suitable ventilating-opening 8, covered by a screen 8'.

A pair of suitable ways 9 may be secured to the bottom of the cabinet and extend from

the front to the rear thereof, said ways being arranged parallel. Upon the ways thus formed are adapted to slide a pair of ribs 10, formed on the under side of a sliding shelf or carrier 11. This carrier is of a width and length to adapt it to readily enter the cabinet and may have its front edge chamfered or beveled, as at 10', so as to avoid the door when the latter is closed, as will be hereinafter explained.

Pins 12 project from the opposite sides of the shelf or carrier, and similar pins 13 project from the sides of a pair of blocks 14, affixed to the inner face of the door. Connected loosely to the pins 12 and 13 is a pair of connecting-rods 15, the same being rigid and having their front ends downwardly curved, as shown. The pins and the connecting-rods are arranged in such relation with the shelf and the door that when the door is closed its elevation will serve to return the shelf or carrier within the cabinet, the carrier readily moving over the ways 9, and when the door is opened or lowered the shelf or carrier is withdrawn from the cabinet sufficiently far to permit of the cheese being cut, the whole operation of withdrawing and returning the carrier being automatic and dependent upon the movements of the door.

A pin 16 may project upwardly from the center of the shelf or carrier, and upon the same may be swiveled a disk 17, the same serving as a convenient support for the cheese, or, if preferred, the cheese may rest directly upon the shelf. The disk, however, being swiveled forms a better and more convenient support, and I prefer to use it, in that the cheese can then be revolved so as to bring any portion adjacent the cutter, and after such cutting its position may be reversed, so as to expose the cut portion to the prospective customers, thus showing the quality and altogether making a much better display.

Secured upon the under side of the shelf or carrier is a stop-bar or cleat 21, the projecting ends of which are adapted to slidingly engage beneath the ribs 20, secured to the inner faces of the sides of the cabinet. The ribs 20 are cut away or recessed to form shoulders 23, against which the cleat 21 is adapted to abut at the moment when the door has reached its horizontal position, so as to pre-

vent further downward movement of the door, and thus prevent undue strain being brought to bear upon the pins 12 13 and rods 15.

As an additional support for the disk I may
5 locate at intervals in the upper side of the shelf loose rollers 21', upon which the said disk near its perimeter may rest.

The panel in the door is solid, and dampness in cabinets as heretofore constructed
10 would swell the panel and push the top rail, so that the door would stick and could not be opened or shut. I avoid said trouble by inserting the screen 8' in the door below the top rail, which allows way for swelling and
15 prevents the door sticking.

In order that the bottom of the cabinet might be readily cleaned or freed from any particles of cheese that might fall onto the same, I cut away the bars 20, as at 22, to provide
20 openings through which the ends of the bar 21 may readily pass. When the carrier is in a position with the ends of the bar 21 opposite the openings 22, the carrier may be lifted and the ends of the bar will pass
25 through the openings, thus giving access to the bottom of the cabinet.

Having described my invention, what I claim is—

1. The combination with a cabinet and a
30 door hinged at the lower edge of the door-opening thereof, of ways arranged on the bottom of the cabinet, a shelf provided with ribs mounted for movement on the ways, curved connecting-bars pivotally connected to the opposite
35 edges of the shelf near its rear end and to the inner face of the door, ribs secured to opposite sides of the cabinet and cut away to form shoulders and also cut away to form

openings and a stop-bar arranged upon the under side of the shelf and slidingly engaging
40 beneath the last-mentioned ribs and adapted to abut against the said shoulders as described and its ends being adapted to pass through the openings of the ribs for the purpose specified.

2. The combination with a cabinet and a door hinged thereto, of ways arranged on the bottom of the cabinet, a shelf having ribs
45 mounted for movement on the ways, ribs upon opposite sides of the cabinet and cut away to form openings, a bar arranged upon the under side of the shelf and slidingly engaging
50 beneath the ribs and its ends being adapted to pass through the openings of the ribs, and pivotal connections between the shelf and the door.

3. The combination with a cabinet and a door hinged at the lower edge of the door-opening, of ways located on the bottom of the cabinet, a shelf mounted to slide on the
60 ways, connecting-rods loosely connected at their opposite ends to the shelf and the door, ribs upon the opposite sides of the cabinet and cut away to form shoulders and a stop-bar arranged upon the under side of the shelf
65 and slidingly engaging beneath the ribs and adapted to abut against the said shoulders when the door is lowered and the shelf moved forward a certain distance in the manner and
70 for the purpose specified.

In testimony whereof I affix my signature in presence of two witnesses.

WILLIAM S. KAUFFMAN.

Witnesses:

WILLIAM R. FOLLMER,
PHILIP B. LINN.