

(19)



(11)

EP 1 630 332 B1

(12)

EUROPEAN PATENT SPECIFICATION

(45) Date of publication and mention of the grant of the patent:
19.08.2009 Bulletin 2009/34

(51) Int Cl.:
E05D 5/02 (2006.01) E05D 7/04 (2006.01)

(21) Application number: **04733575.7**

(86) International application number:
PCT/ES2004/000220

(22) Date of filing: **18.05.2004**

(87) International publication number:
WO 2004/104341 (02.12.2004 Gazette 2004/49)

(54) **HINGE SYSTEM FOR FOLDING DOORS**

SCHARNIERSYSTEM FÜR FALTTÜREN

SYSTEME D'ARTICULATION POUR PORTES PLIABLES

(84) Designated Contracting States:
AT BE BG CH CY CZ DE DK EE ES FI FR GB GR HU IE IT LI LU MC NL PL PT RO SE SI SK TR

(72) Inventor: **TARREGA I LLORET, Miguel, Angel E-08017 Barcelona (ES)**

(30) Priority: **23.05.2003 ES 200301210**

(74) Representative: **Carvajal y Urquijo, Isabel et al Clarke, Modet & Co. Goya 11 28001 Madrid (ES)**

(43) Date of publication of application:
01.03.2006 Bulletin 2006/09

(73) Proprietor: **KLEIN IBÉRICA, S.A. 08110 Montcada i Reixac (Barcelona) (ES)**

(56) References cited:
EP-A1- 0 528 213 EP-A1- 0 995 001
CH-A- 524 750 DE-A1- 2 248 217
US-A- 2002 035 765

EP 1 630 332 B1

Note: Within nine months of the publication of the mention of the grant of the European patent in the European Patent Bulletin, any person may give notice to the European Patent Office of opposition to that patent, in accordance with the Implementing Regulations. Notice of opposition shall not be deemed to have been filed until the opposition fee has been paid. (Art. 99(1) European Patent Convention).

Description

OBJECT OF THE INVENTION

[0001] The present invention refers to a linkage system that has been especially designed for linking the two sections or leaves of a folding door, in which said leaves are susceptible of adopting a coplanar arrangement, specifically in the closed position, or a parallel or adjacent arrangement, in turn specifically in the open position.

[0002] The object of the invention is to achieve a firm fixing between the linkage system and the two leaves that must be linked, assuring perfect maintenance of the relative position which said leaves must adopt at all times and further allowing the easy pivoting of one leaf with respect to the other during the door opening and closing operations.

BACKGROUND OF THE INVENTION

[0003] The usual structure of a folding door consists of two leaves identical in size that are joined together by means of hinging through one of their vertical edges such that one of said leaves, and through its free vertical edge, is joined by means of hinges to the door frame, whereas the other leaf, also at its free edge, has guide means complementary to others existing on the upper cross-piece of the frame, and sometimes on the floor, such that the door in the opened position forms a dihedral with a virtually nil angulation which, during door closing, is increased up to 180°, the opening of the dihedral being permanently maintained on an imaginary plane, the one corresponding to the frame guide, see for example US 20020035765 A.

[0004] Due to the nature of said leaves, usually made of wood, they contribute a substantial weight which is transmitted from one leaf to the other one through the hinges, and more specifically through the screws or wood screws with which the hinges are joined to the leaves of the door, which brings about the occurrence of allowances and the door becoming unhitched with the normal operation thereof, negatively and significantly affecting the door closing conditions on the corresponding frame.

[0005] Spanish patent 9800482 of the same applicant discloses a folding door made up of two leaves joined together by means of hinges. These hinges are fixed to the leaves of the door by means of a plurality of screws, which requires certain operations at the time of installing or assembling the door which, due to their complexity and the time required, may be inconvenient. On the other hand, the hinge fixing system is the reason that misalignments and allowances occur with a certain frequency.

DESCRIPTION OF THE INVENTION

[0006] The linkage system proposed by the invention resolves in a fully satisfactory manner the drawbacks previously set forth, even in doors with considerably greater

weight than what is usual.

[0007] To that end and more specifically, said system is based on embedding a metallic profile in the edge of each one of the doors intended for being linked to the other one, the length of said profile coinciding with that of said edge, i.e. said profile affects said edge in its entirety, which profile is permanently fixed to the corresponding leaf by means of a longitudinal alignment of screws assuring that said fixing is completely firm, without the possibility of the smallest amount of allowance occurring.

[0008] Each one of said profiles adopts a grooved configuration with a narrowed opening, and it is intended for internally receiving, by longitudinal sliding, one of the blades of the group of hinges collaborating in the door, which blades are provided on their edge opposite to the hinge with a head having a constant profile that is suitable in shape and size for being coupled in a tongue and groove manner to the corresponding metallic profile at the level of the opening thereof, and to which it is fixed by wedging under pressure with the collaboration of a pair of screws (3) traversing said head pressing against the bottom of the profile, specifically between a pair of longitudinal ribs, and which are permanently locked with the collaboration of respective stay bolts. It is thus achieved that each hinge blade is fixed to the corresponding profile through wide surfaces and with a strong pressure also making it impossible at any point for allowances between the blade and profile, in other words, between the hinge and door leaf, to occur.

[0009] It has further been provided that in said profile fixable to the edge of each leaf, immediately outside of its wide central groove, two grooves are arranged allowing the implementation of a gasket in one of them which acts on the gasket of the other leaf in the closed door position.

[0010] It has also been provided according to another one of the features of the invention that the cylindrical core of one of the blades of one of the hinges, through which the pivot shaft passes, has a recess in which there is arranged a handle, coaxially arranged on said shaft and facilitating the door opening operation.

DESCRIPTION OF THE DRAWINGS

[0011] To complement the description being made and for the purpose of aiding to better understand the features of the invention according to a preferred embodiment thereof, a set of drawings is attached as an integral part of said description in which, with an illustrative and non-limiting character, the following has been depicted:

Figure 1 shows a cross-sectional view of a partial detail of one of the leaves of a folding door provided with the linkage system constituting the object of the present invention, at the level of the area thereof where the longitudinal profile stiffening its linkage edge is arranged.

Figure 2 shows a frontal view of the detail of the previous figure.

Figure 3 shows a front elevational view of one of the hinges linking the two leaves, specifically the leaf provided with a handle.

Figure 4 shows a profile of the assembly depicted in the previous figure in the same extension position for the hinge corresponding to the door opening position.

Figure 5 shows the same assembly of Figure 4 according to the same view, but in the door closing position.

Lastly, Figure 6 shows a detail of the locking of one of the fixing screws for fixing the hinges to the stiffening profiles of the leaves of the door.

PREFERRED EMBODIMENT OF THE INVENTION

[0012] Figures 1 and 2 partially depict the marginal area of one of the leaves (1) collaborating in the folding door, and it can be observed how, in correspondence with one of its vertical edges, the one that is hinged to the other one, it incorporates a wide longitudinal groove (2) in which a grooved profile (3), basically having a U-shaped section, provided on its middle branch with an abundant longitudinal alignment of openings (4) for the passage of respective fixing screws (5) to the leaf (1), tightly fits, such that the profile (3) is firmly attached to the latter.

[0013] The profile (3), defining a wide groove (6), has a remarkably narrowed opening (7) thereof, as is particularly observed in Figure 1, in order to allow the tongue and groove coupling by sliding into said groove (6) of the head (8) finishing off each one of the blades (9) of the hinges, which blades, as is typical, are linked to one another through a pivot shaft (10) functioning inside cylindrical expansions of said blades (9).

[0014] More specifically, in the chosen practical embodiment, the narrowed opening (7) of the opening of the grooved profile (3) is dovetailed, the head (8) of the blades (9) adopting an also dovetailed configuration, such that each head (8) is easily coupled into the groove (6) by sliding from one of the ends of the profile (3).

[0015] After the selection of the chosen position for the hinge, the final fixing thereof is carried out with the collaboration of a pair of robust screws (11), preferably Allen-type screws, traversing threaded openings of the head (8) and acting as stay bolts on the bottom of the profile (3), specifically acting between a pair of longitudinal ribs (12) projecting from the base of the profile, on either side of the alignment of fixing openings (4), as can also be observed in Figure 1, such that these screws (11) strongly press the corresponding head (8) against the slanted planes defined in the narrowed opening (7) of the profile (3).

[0016] For the purpose of preventing the accidental loosening of said screws (11), it has been provided that each one of them is accompanied by a small stay bolt

(13) radially acting thereon from the corresponding edge of the head (8).

[0017] Outside of its wide central groove (6) and maintaining its general symmetry, the grooved profile (3) further incorporates a pair of grooves (14) selectively usable for the implementation of a gasket (15) which, in the closed door position shown in Figure 5, acts on the gasket of the other leaf, forming a perfect seal between the two leaves of the door in such position.

[0018] As a complement of the described structure, one of the hinges collaborating in the door, the one occupying the position at the height that is most suitable for easy manual access thereto, incorporates in the cylindrical core (16) of one of its blades (9) a recess (17) leaving its shaft (10) free for locating in said recess a handle (18) coaxially coupled to the shaft (10) and facilitating the opening of the door, i.e. the folding of one of the leaves over the other one.

Claims

1. A linkage system for folding doors, of the type structured by means of two leaves joined together by means of hinges, **characterized in that** each one of said leaves (1) incorporates, in correspondence with its vertical edge which is joined by hinges to the other leaf, a wide groove (2) in which an also grooved metallic profile (3) tightly fits, the groove (6) of which has a narrowed opening (7) for the tongue and groove coupling thereto of a complementary head (8) finishing off one of the blades (9) of each one of the hinges participating in the door, having been provided that said head (8) is movable by sliding through the groove (6) and fixable at any chosen point thereof by means of at least one pair of setscrews (11) which traverse threaded openings of the head (8) itself and which, by acting on the bottom of the groove (6) of the profile (3), press said head (8) against the narrowed opening (7) of such groove (6).
2. A linkage system for folding doors according to claim 1, **characterized in that** said profile (3) incorporates in its middle branch a longitudinal alignment of openings (4) for its fixing by screwing to the bottom of the groove (2) of the leaf (1) of the door, said alignment of openings (4) being surrounded by a pair of longitudinal ribs (12) between which the inner end of the setscrews (11) acts.
3. A linkage system for folding doors according to claim 1, **characterized in that** the head (8) finishing off each blade (9) of the hinges adopts a dovetail profile, whereas the narrowed opening of the groove (6) of the profile (3) fixed to the leaf (1) adopts a complementary configuration.
4. A linkage system for folding doors according to claim

- 1, **characterized in that**, with each one of the set-screws (11) through which the fixing of each head (8) to the profile (3) is carried out, another stay bolt (13) collaborates which radially acts thereon inside the head itself and which acts as a locking means for the former.
5. A linkage system for folding doors according to claim 1, **characterized in that** the metallic profile (3) incorporates, outside of its wide central groove (6) with a narrowed opening, respective symmetrical grooves (14) selectively usable for the implementation of a gasket (15) acting on that of the opposite profile in the closed door position.
6. A linkage system for folding doors according to the previous claims, **characterized in that** one of the blades (9) of one of the hinges of the door, intended for adopting an arrangement at the height suitable for its manual gripping, incorporates in its cylindrical neck (16) for housing the shaft (10) of the hinge a recess (17) in which a handle (18) fits, which is coaxially assembled on the shaft (10) itself and intended for operating the door, especially in the opening direction thereof.

Patentansprüche

1. Verbindungssystem für Falttüren, von dem Typ, der aus zwei Türblättern zusammengesetzt ist, die mittels Scharnieren miteinander verbunden sind, **dadurch gekennzeichnet, dass** jedes der Türblätter (1) in Engtsprechung mit seiner senkrechten Kante, die durch Scharniere mit dem anderen Türblatt verbunden ist, eine breite Nut (2) umfasst, in welche ein ebenfalls genutetes Metallprofil (3) fest eingepasst ist, wobei dessen Nut (6) eine verengte Öffnung (7) für die Feder-Nut-Verbindung eines komplementären Kopfes (8) daran aufweist, der eines der Bänder (9) von jedem der an der Tür beteiligten Scharniere abschließt, wobei vorgesehen ist, dass der Kopf (8) durch Gleiten durch die Nut (6) beweglich und an einem beliebigen gewählten Punkt davon mittels mindestens eines Paares von Gewindestiften (11) befestigbar ist, welche durch gewindete Öffnungen des Kopfes (8) selbst hindurch verlaufen und welche durch Einwirken auf den Boden der Nut (6) des Profils (3) den Kopf (8) gegen die verengte Öffnung (7) der Nut (6) drücken.
2. Verbindungssystem für Falttüren nach Anspruch 1, **dadurch gekennzeichnet, dass** das Profil (3) in seinem mittleren Abschnitt eine in Längsrichtung ausgerichtete Anordnung von Öffnungen (4) für dessen Befestigung durch Anschrauben an den Boden der Nut (2) des Türblatts (1) der Tür umfasst, wobei die ausgerichtete Anordnung von Öffnungen (4) von

einem Paar von Längsrippen (12) umgeben ist, zwischen denen das innere Ende der Gewindestifte (11) einwirkt.

3. Verbindungssystem für Falttüren nach Anspruch 1, **dadurch gekennzeichnet, dass** der Kopf (8), welcher jedes Band (9) der Scharniere abschließt, ein Schwalbenschwanzprofil aufweist, wohingegen die verengte Öffnung der Nut (6) des Profils (3), das an dem Türblatt (1) befestigt ist, eine komplementäre Konfiguration aufweist.
4. Verbindungssystem für Falttüren nach Anspruch 1, **dadurch gekennzeichnet, dass** mit jedem der Gewindestifte (11), durch welche die Befestigung jedes Kopfes (8) an dem Profil (3) erfolgt, ein anderer Ankerbolzen (13) zusammenwirkt; der innerhalb des Kopfes selbst radial darauf einwirkt und der als Verriegelungsmittel für ersteren dient.
5. Verbindungssystem für Falttüren nach Anspruch 1, **dadurch gekennzeichnet, dass** das Metallprofil (3) außerhalb seiner breiten mittigen Nut (6) mit einer verengten Öffnung entsprechende symmetrische Nuten (14) umfasst, die wahlweise für die Implementierung einer Dichtung (15) verwendet werden können, welche in der geschlossenen Türposition auf jene des gegenüberliegenden Profils wirkt.
6. Verbindungssystem für Falttüren nach den vorangehenden Ansprüchen, **dadurch gekennzeichnet, dass** eines der Bänder (9) von einem der Scharniere der Tür, welches zum Ausbilden einer Anordnung in der Höhe bestimmt ist, die für ihr Ergreifen von Hand geeignet ist, in seinem zylindrischen Hals (16) zum Aufnehmen der Weite (10) des Scharniers eine Ausnehmung (17) umfasst, in welche ein Griff (18) passt, der koaxial an der Welle (10) selbst montiert und zum Betätigen der Tür, insbesondere in ihrer Öffnungsrichtung, bestimmt ist.

Revendications

1. Système d'articulation pour portes pliables, du type structuré au moyen de deux battants joints l'un à l'autre au moyen de gonds., **caractérisé en ce que** chacun desdits battants (1) incorpore, en correspondance avec son bord vertical qui est joint par des gonds à l'autre battant, une large gorge (2) dans laquelle un profil métallique également rainuré (3) s'adapte étroitement, la gorge (6) a une ouverture rétrécie (7) pour la langue et l'accouplement de gorge à celle-ci d'une tête complémentaire (8) finissant l'une des lames (9) de chacun des gonds participant à la porte, ladite tête (8) étant mobile en coulissant à travers la gorge (6) et pouvant être fixée à n'importe quel point choisi de celle-ci au moyen d'au moins

une paire de vis (11) qui traversent des ouvertures filetées de la tête (8) proprement dite et qui, en agissant au fond de la gorge (6) du profil (3), pressent ladite tête (8) contre l'ouverture rétrécie (7) de la gorge (6).

5

2. Système d'articulation pour portes pliables selon la revendication 1, **caractérisé en ce que** ledit profil (3) incorpore dans sa branche du milieu un alignement longitudinal d'ouvertures (4) pour sa fixation par vissage au fond de la gorge (2) du battant (1) de la porte, ledit alignement d'ouvertures (4) étant entouré d'une paire de nervures longitudinales (12) entre lesquelles l'extrémité intérieure des vis (11) agit.

10

15
3. Système d'articulation pour portes pliables selon la revendication 1, **caractérisé en ce que** la tête (8) finissant chaque lame (9) des gonds adopte un profil en queue-d'aronde, tandis que l'ouverture rétrécie de la gorge (6) du profil (3) fixé au battant (1) adopte une configuration complémentaire.

20
4. Système d'articulation pour portes pliables selon la revendication 1, **caractérisé en ce que**, avec chacune des vis (11) par lesquelles la fixation de chaque tête (8) au profil (3) est effectuée, un autre boulon de maintien (13) collabore en agissant radicalement sur celle-ci à l'intérieur de la tête proprement dite et en agissant en tant que moyen de verrouillage de vis.

25

30
5. Système d'articulation pour portes pliables selon la revendication 1, **caractérisé en ce que** le profil métallique (3) incorpore, à l'extérieur de sa gorge centrale large (6) avec une ouverture rétrécie, des gorges symétriques respectives (14) utilisables sélectivement pour la mise en oeuvre d'un joint (15) agissant sur celui du profil opposé à la position de porte fermée.

35
6. Système d'articulation pour portes pliables selon l'une quelconque des revendications précédentes, **caractérisé en ce que** l'une des lames (9) de l'un des gonds de la porte, destinée à adopter un agencement à la hauteur appropriée pour la prendre manuellement, incorpore dans son col cylindrique (16) pour héberger l'arbre (10) du gond un renforcement (17) dans lequel une poignée (18) s'adapte, qui est coaxialement assemblée sur l'arbre (10) proprement dit et destinée à l'utilisation de la porte, particulièrement dans la direction d'ouverture de celle-ci.

40

45

50

55

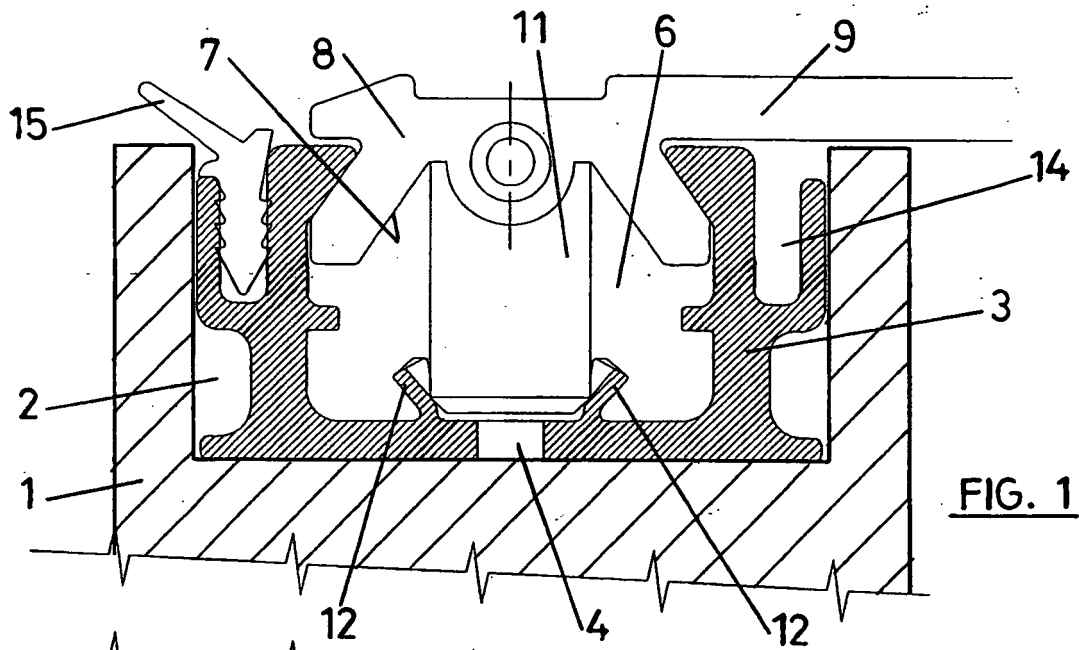

FIG. 1

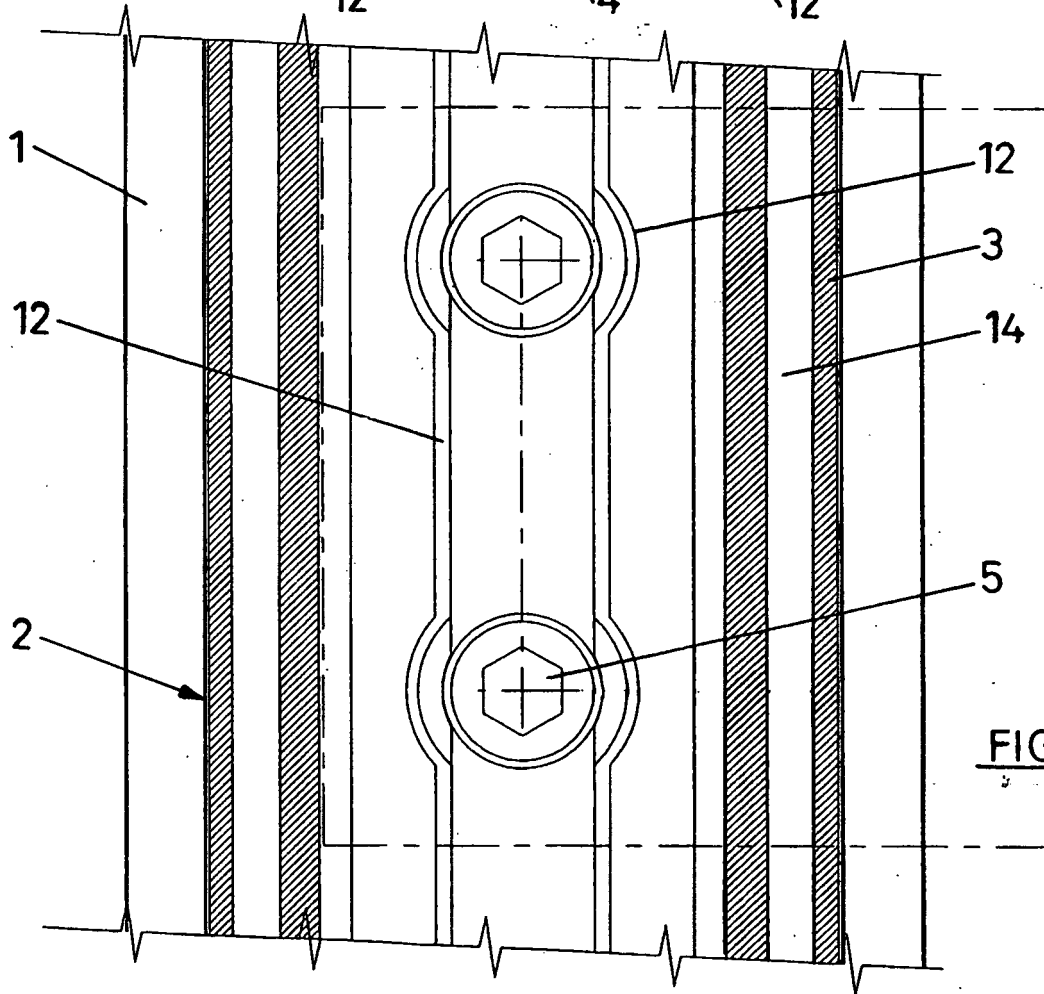
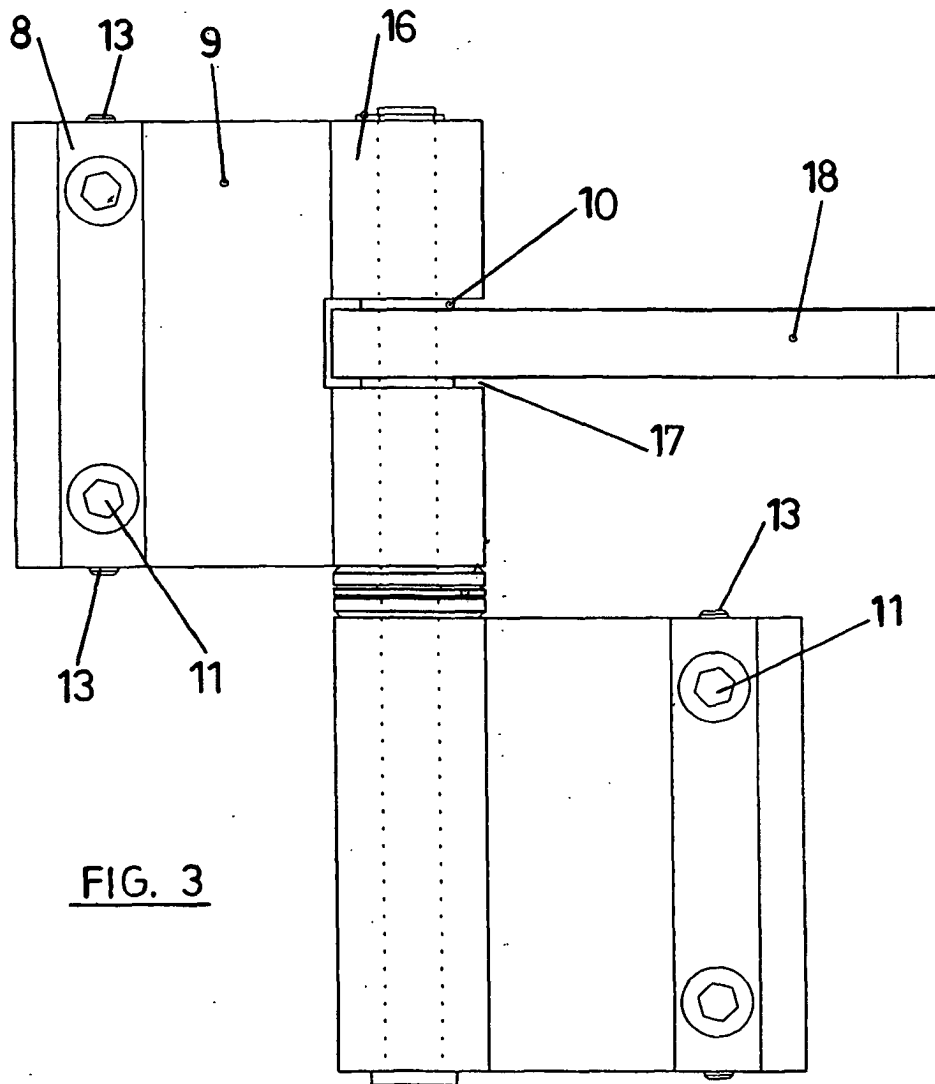
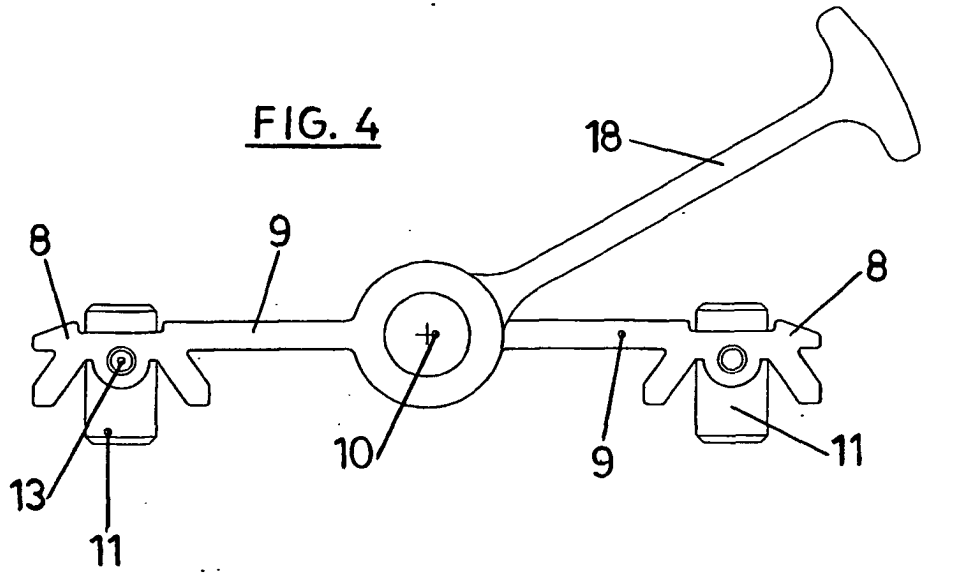
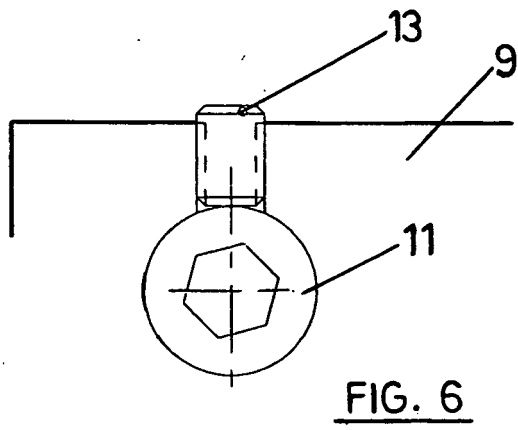
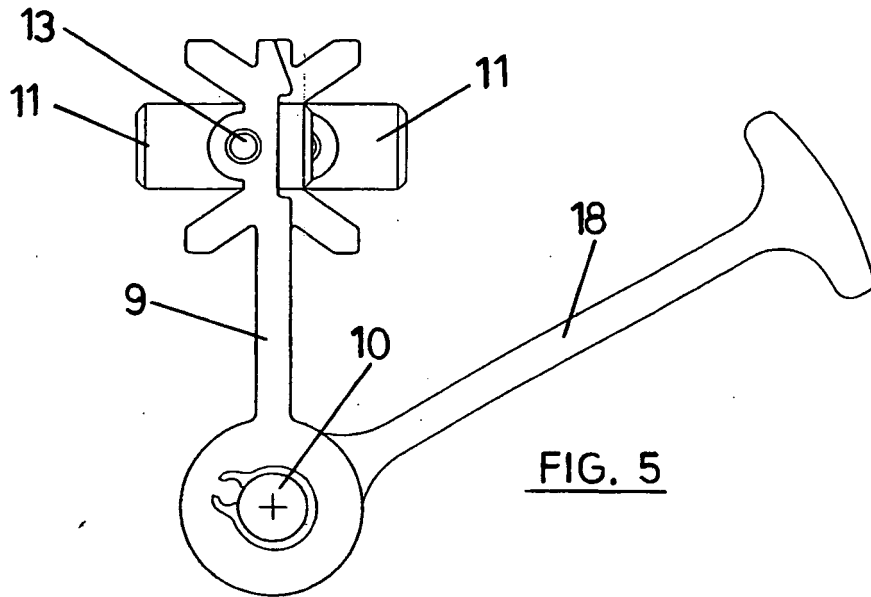

FIG. 2





REFERENCES CITED IN THE DESCRIPTION

This list of references cited by the applicant is for the reader's convenience only. It does not form part of the European patent document. Even though great care has been taken in compiling the references, errors or omissions cannot be excluded and the EPO disclaims all liability in this regard.

Patent documents cited in the description

- US 20020035765 A [0003]
- ES 9800482 [0005]