



(12) **EUROPEAN PATENT APPLICATION**

(43) Date of publication:
25.11.2009 Bulletin 2009/48

(51) Int Cl.:
A47F 7/02 (2006.01) A47F 7/024 (2006.01)

(21) Application number: **09160583.2**

(22) Date of filing: **19.05.2009**

(84) Designated Contracting States:
AT BE BG CH CY CZ DE DK EE ES FI FR GB GR HR HU IE IS IT LI LT LU LV MC MK MT NL NO PL PT RO SE SI SK TR

(72) Inventor: **Pirovano, Giorgio**
23891, Barzano' (LC) (IT)

(30) Priority: **22.05.2008 IT MI20080940**

(74) Representative: **Raimondi, Margherita et al**
Dott. Ing. Prof. Alfredo Raimondi S.r.l.,
Piazzale Cadorna, 15
20123 Milano (IT)

(71) Applicant: **Sarno Display S.r.l. - Socio Unico**
23891 Barzanò (IT)

(54) **Device for holding and retaining articles to be displayed and display unit provided with this device**

(57) Device for holding and retaining articles (1) to be displayed, comprising a front panel (10) which is provided with at least one slot (11) and which has, integral therewith, at least one support (12) for the article (1); a rear closing panel (40) which has, formed therein, at least one slot (41) aligned with the slot (11) of the front panel (10); a frame (30) arranged between the two - front and rear - panels and provided with a rack (31), a slider (20) which is displaceable inside said frame and which is provided on its surface with a first seat (21) having an opening (21a) situated opposite said rack (31), a second seat (24) aligned in the longitudinal direction with the first seat (21) and an eyelet (26) open in a direction at right angles to the opening (21a) of the first seat (21), a ratchet (22) housed in the first seat (21) of the slider (20) and provided

with a tooth (22a) passing through the side opening (21a) and having a first magnet (23) of given polarity, the longitudinal dimensions of the ratchet being such as to allow displacement thereof inside the seat (21) from a position where the tooth (22a) is retracted into a position where the tooth protrudes from the side opening (21a) for engagement with the rack (31); a second fixed magnet (25) which is housed in the second seat (24) and which has the same polarity as that of the first magnet (23), the interaxial distance between the first magnet (23) and the second magnet (25) being such as to cause interaction of the two respective magnetic fields; a magnet (50) with a polarity opposite to that of the other two magnets and with a magnetic strength greater than that of the second fixed magnet (25).

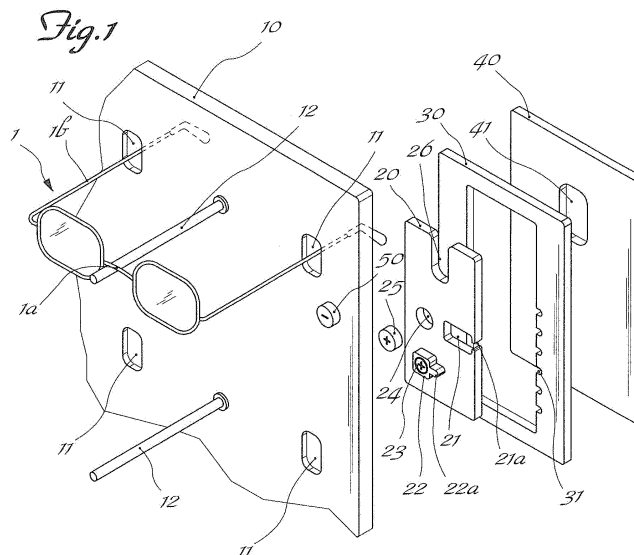

Description

[0001] The present invention relates to a device for holding and retaining articles to be displayed.

[0002] It is known in the technical sector relating to the display of various articles for sale that there exists the need to make said articles highly visible to a potential purchaser, so that the prechosen article may be easily selected, but ensure at the same time safety of the displayed articles which must be secured to the display unit so as to prevent unauthorized removal thereof.

[0003] An example of this need consists in the display units for spectacles where it is required to provide substantially vertical racks for display of the various models.

[0004] It is also known that, for this purpose, the display units are provided with opening/closing devices controlled by movable parts so as to form seats for supporting the bridge-piece of the spectacles so that they are retained inside the said seat if not opened by authorized personnel.

[0005] Although fulfilling their function, these devices are, however, complex to manufacture, costly and not particularly modular so as to be adaptable to the size of the display unit actually required depending on the specific application and/or number of articles to be displayed.

[0006] The technical problem which is posed, therefore, is to provide a modular device able to form seats which can be opened and closed and are designed to retain articles on display such as, for example, spectacles and the like, which allows in particular opening and closing of the various seats individually, in order to release or lock one article at a time leaving the other articles locked.

[0007] In connection with this problem it is also required that this device should have small dimensions, be easy and inexpensive to produce and assemble and should allow optimum viewing of the article by the potential purchaser.

[0008] These results are achieved according to the present invention by a device for holding and retaining articles to be displayed according to the characteristic features of Claim 1.

[0009] Further details may be obtained from the following description of a non-limiting example of embodiment of the subject of the present invention provided with reference to the accompanying drawings in which:

Figure 1 is an exploded view of a display unit with the locking device according to the present invention;

Figure 2 is a rear view of the device assembled and in the position for locking an article;

Figure 3 is a front view of the device according to Fig. 1 during engagement of the slider with the fixed frame;

Figure 4 is a front view of the device according to Fig. 1 during release of the slider from the fixed frame;

Figure 5 is a view of the device according to Fig. 1 during the closing movement;

Figure 6 is a front view of the device according to Fig. 1 during renewed engagement with the fixed frame.

[0010] As shown in Fig. 1 and assuming solely for the sake of convenience of the description and without a limiting meaning a set of three reference axes in the longitudinal direction X-X, transverse direction Y-Y and vertical direction Z-Z, respectively, as well as a front part corresponding to the side where the spectacles are displayed and a rear part opposite to the front part, the locking device according to the invention comprises essentially:

- a front panel 10 which is provided with at least two slots 11 suitably spaced from each other in the longitudinal direction X-X and which has, integral therewith, at least one pin 12 extending outwards in the transverse direction Y-Y;
- a slider 20 which has, formed in its surface, a first seat 21 with a side opening 21a, a second seat 24 aligned in the longitudinal direction with the first seat; and an eyelet 26 which is open in a direction at right angles (vertical in the example shown in the figures) to the opening 21a of the first seat 21.

[0011] The first seat 21 houses a ratchet 22 which has a first magnet 23 of given polarity; the ratchet has a side tooth 22a and longitudinal dimensions such as to allow displacement of the assembly inside the seat 21 from a position where the tooth 22a is retracted inside the said seat into a position where the tooth protrudes from the side opening 21a.

[0012] The second seat 24 houses a second fixed magnet 25 having a polarity the same as that of the first magnet 23; the interaxial distance between the two magnets 23,25 is such as to produce an interaction of the two respective magnetic fields and therefore a thrusting force, in the longitudinal direction X-X, of the first magnet on the second magnet which is forced to move away in the longitudinal direction X-X;

- a frame 30 for containing the slider 20, which has, formed on its inner side, a rack 31 in a position opposite the opening 21a of the first seat 21 of the slider 20 and with a length substantially equal to the travel of the slider itself;
- a rear closing panel 40 which is provided with a slot 41 corresponding to the slot 11 in the front panel 10;
- a magnet 50 with a polarity opposite to that of the other two magnets and a magnetic strength greater than that of the second fixed magnet 25.

[0013] The device is assembled so that the slots 11 of the front panel 10 and slot 41 of the rear panel 40 coincide and the frame 30 with the associated cursor 20 is ar-

ranged between the two panels so that the eyelet 26 is in turn arranged aligned with the two - front 11 and rear 41 - slots.

[0014] With this configuration the operating principle of the device is now described:

- in normal conditions the slider is positioned so that the eyelet 26 leaves the slots 11 and 41 open;
- in this position the slider 20 is locked by the tooth 22a which engages with the first notch of the rack 31, being pushed by the reaction of the two magnets 23,25 with the same polarity which cause the ratchet 22 to move away in the longitudinal direction of the ratchet 22 and the tooth 22a to come out of the side opening 21a of the slider;
- in these conditions it is possible to arrange the spectacles 1 with the bridge-piece 1a on the pin 12 and the end part of the side arms 1b inserted through the slots 11,41;
- once the free end of the side arms 1b has been inserted inside the eyelets the magnet 50 is arranged in the vicinity of the fixed magnet 25 of the slider 20, causing elimination of the magnetic field which is the same as that of the first magnet 23 and the formation of a residual magnetic field of opposite polarity which, interacting with the magnetic field of the first magnet 23, causes recalling in the longitudinal direction of the ratchet 22 which, moving towards the inside, disengages the tooth 22a from the rack 31, freeing the slider 20;
- the magnet 50 is moved in the vertical direction Z-Z and, co-operating with the magnets 25,23 of the slider, causes displacement of the latter upwards (as per the orientation shown in the figures), resulting in partial closing off of the slots 11, 41 by the eyelet 26,
- once the end of travel of the slider 20 has been reached, the magnet 50 is moved away, causing interaction again of the same magnetic fields of the two magnets 25,23 of the slider, which push again outwards the ratchet 22, engaging the tooth 21a inside the last notch of the rack 31, so as to cause locking in position of the slider 20 and therefore the side arms of the spectacles 1 which cannot be removed from the display unit.

[0015] In order to extract the spectacles the same sequence must be performed, but in the reverse direction, so as to move the slider into the position such as to open again the slots of the display unit.

[0016] It is therefore clear how, with the device and the display unit according to the invention, it is possible to display articles such as spectacles and the like in an optimum manner for viewing thereof by the potential purchaser and how display is also made safer against unwanted removal of the articles, via the means for opening and closing the seat for holding a part of the article to be displayed.

[0017] In addition to the above, it is particularly advan-

tageous that each holding seat can be closed and opened individually without having to open or close all the seats available on the display unit.

5

Claims

1. Device for holding and retaining articles (1) to be displayed, **characterized in that** it comprises:

10

- a front panel (10) which is provided with at least one slot (11) and which has, integral therewith, at least one support (12) for the article (1);

15

- a rear closing panel (40) which has, formed therein, at least one slot (41) aligned with the slot (11) of the front panel (10);

20

- a frame (30) arranged between the two - front and rear - panels and provided with a rack (31),
- a slider (20) which is displaceable inside said frame and which is provided on its surface with a first seat (21) having an opening (21a) situated opposite said rack (31), a second seat (24) aligned in the longitudinal direction with the first seat (21) and an eyelet (26) open in a direction at right angles to the opening (21a) of the first seat (21);

25

- a ratchet (22) housed in the first seat (21) of the slider (20) and provided with a tooth (22a) passing through the side opening (21a) and having a first magnet (23) of given polarity, the longitudinal dimensions of the ratchet being such as to allow displacement thereof inside the seat (21) from a position where the tooth (22a) is retracted into a position where the tooth protrudes from the side opening (21a) for engagement with the rack (31);

30

- a second fixed magnet (25) which is housed in the second seat (24) and which has the same polarity as that of the first magnet (23), the interaxial distance between the first magnet (23) and the second magnet (25) being such as to cause interaction of the two respective magnetic fields;

35

- a magnet (50) with a polarity opposite to that of the other two magnets and with a magnetic strength greater than that of the second fixed magnet (25).

45

2. Device according to Claim 1, **characterized in that** said front panel has at least two slots which are suitably spaced from each other in the longitudinal direction (X-X).

50

3. Device according to Claim 1, **characterized in that** said support (12) consists of a part extending outwards in the direction (Y-Y) at right angles to the front panel (10).

55

4. Device according to Claim 1, **characterized in that** said rack extends in a direction (Z-Z) at right angles to the direction (X-X) of the tooth (21a) of the ratchet (22). 5
5. Display unit, **characterized in that** it comprises at least one device for holding and retaining articles (1) to be displayed according to Claim 1. 10
6. Display unit according to Claim 5, **characterized in that** it is a display unit for spectacles (1) comprising a bridge-piece (1b) and side arms (1a). 15
7. Display unit according to Claim 6, **characterized in that** the opening/closing device acts on the side arms (1b) of the spectacles. 20

20

25

30

35

40

45

50

55

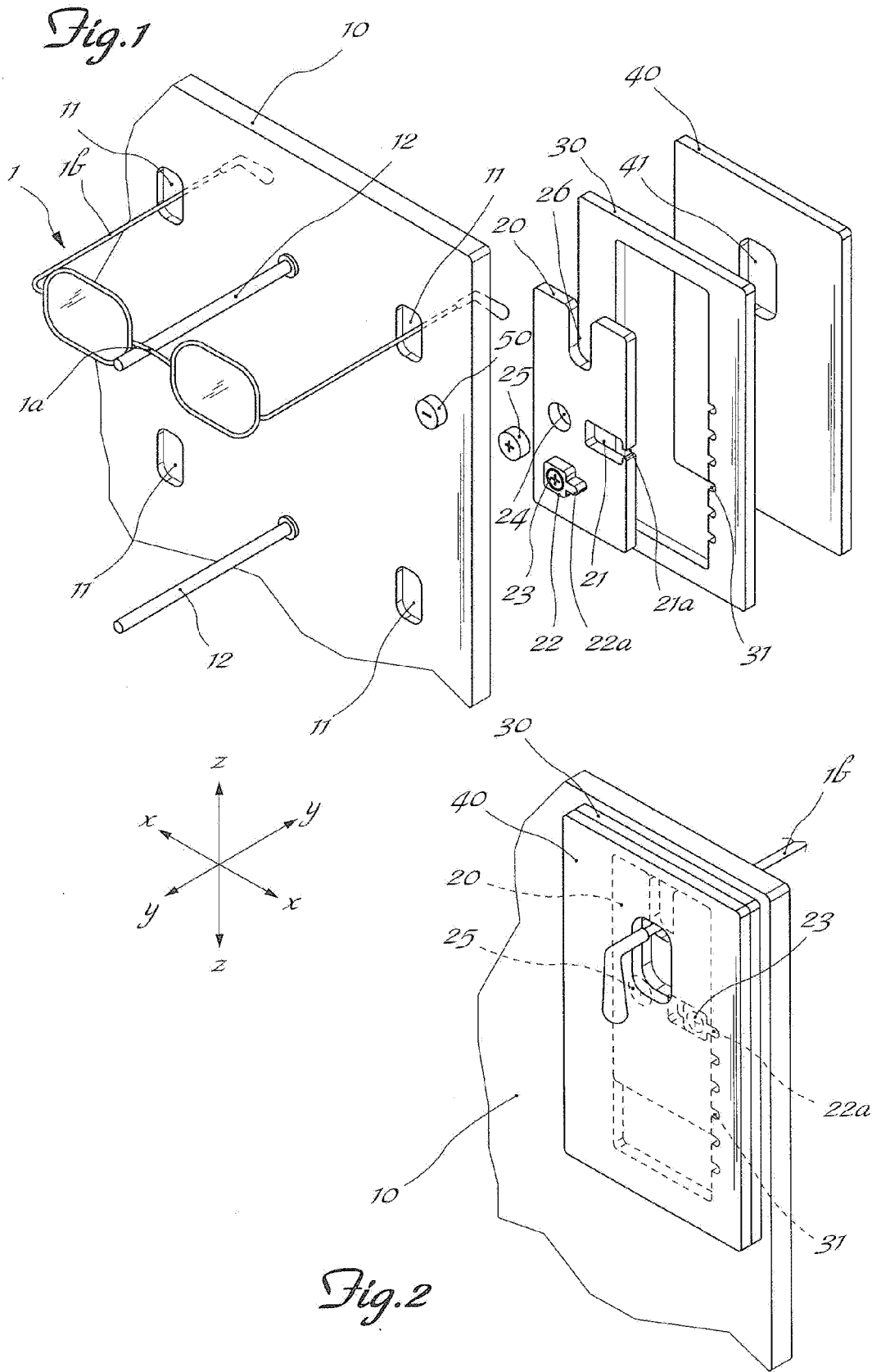

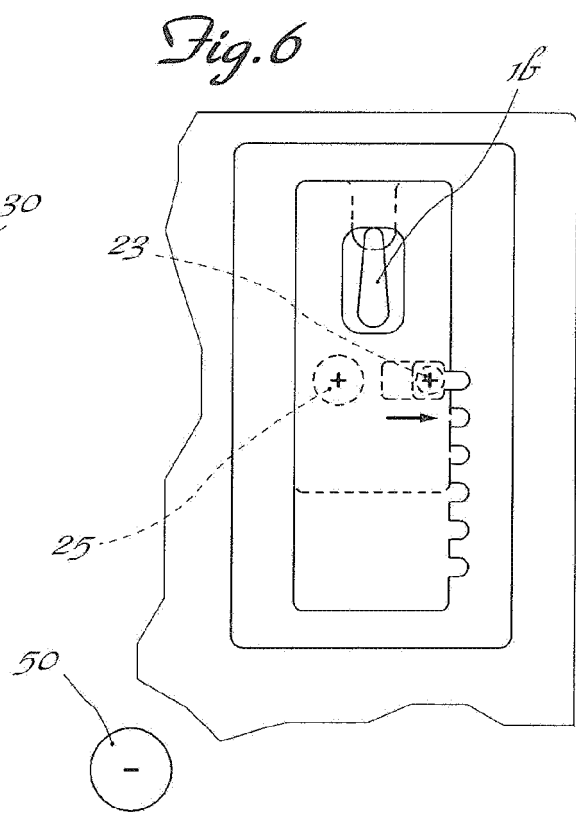
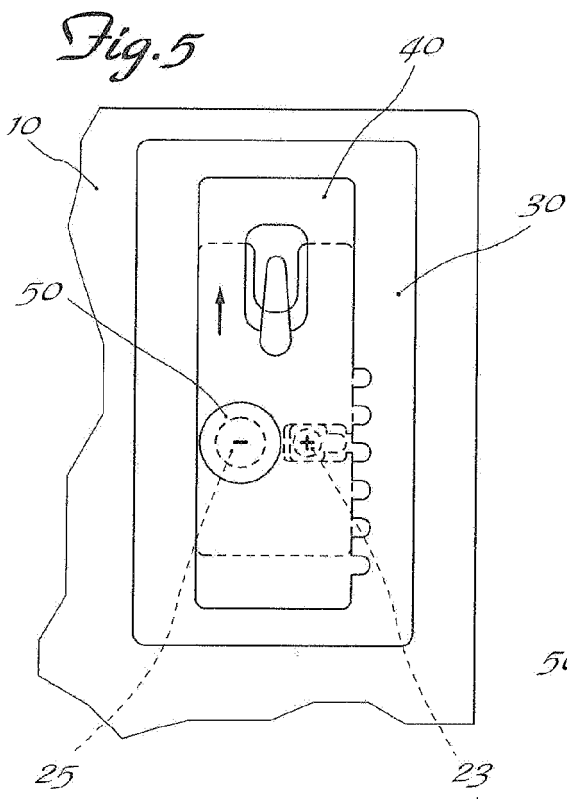
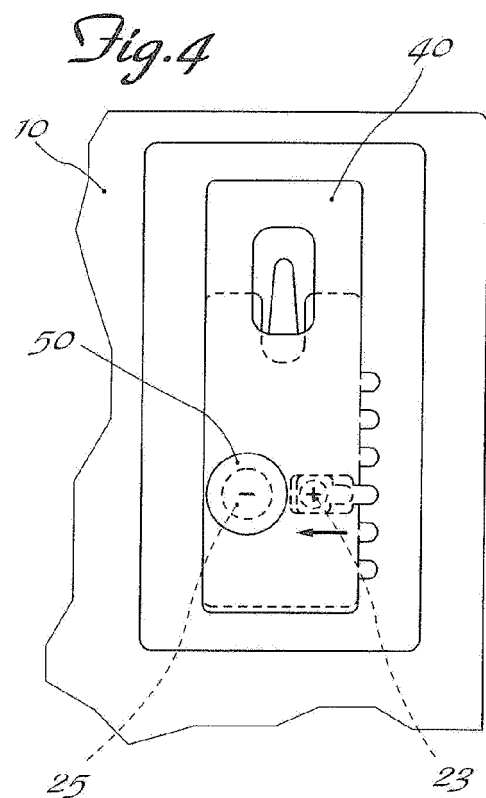
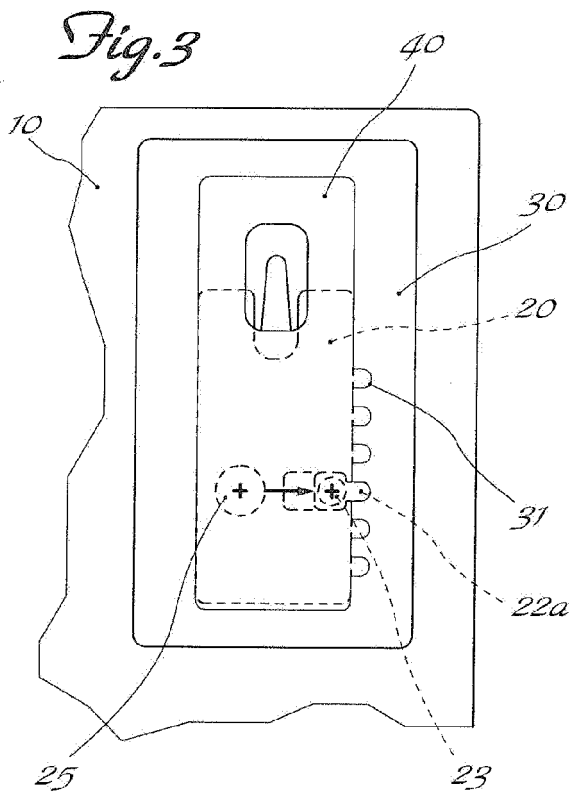



EUROPEAN SEARCH REPORT

Application Number
EP 09 16 0583

DOCUMENTS CONSIDERED TO BE RELEVANT			
Category	Citation of document with indication, where appropriate, of relevant passages	Relevant to claim	CLASSIFICATION OF THE APPLICATION (IPC)
A	DE 199 00 843 A1 (MEDIA EINRICHTUNG GMBH [DE]) 13 July 2000 (2000-07-13) * the whole document * -----	1-7	INV. A47F7/02 A47F7/024
A	US 6 382 432 B1 (HSIEH TZAISHU [TW]) 7 May 2002 (2002-05-07) * the whole document * -----	1-7	
A	DE 199 63 201 A1 (LUTZ THOMAS [DE]) 6 September 2001 (2001-09-06) * the whole document * -----	1-7	
A	FR 2 204 119 A (BOUCHARDON SERGE [FR]) 17 May 1974 (1974-05-17) * the whole document * -----	1-7	
A	DE 10 2005 003573 A1 (PINTUR MLADEN [HR]) 27 July 2006 (2006-07-27) * the whole document * -----	1-7	
			TECHNICAL FIELDS SEARCHED (IPC)
			A47F
The present search report has been drawn up for all claims			
Place of search Munich		Date of completion of the search 13 August 2009	Examiner Cardan, Cosmin
CATEGORY OF CITED DOCUMENTS		T : theory or principle underlying the invention E : earlier patent document, but published on, or after the filing date D : document cited in the application L : document cited for other reasons & : member of the same patent family, corresponding document	
X : particularly relevant if taken alone Y : particularly relevant if combined with another document of the same category A : technological background O : non-written disclosure P : intermediate document			

1 EPO FORM 1503 03.82 (P04C01)

**ANNEX TO THE EUROPEAN SEARCH REPORT
ON EUROPEAN PATENT APPLICATION NO.**

EP 09 16 0583

This annex lists the patent family members relating to the patent documents cited in the above-mentioned European search report. The members are as contained in the European Patent Office EDP file on
The European Patent Office is in no way liable for these particulars which are merely given for the purpose of information.

13-08-2009

Patent document cited in search report	Publication date	Patent family member(s)	Publication date
DE 19900843	A1	13-07-2000	NONE

US 6382432	B1	07-05-2002	NONE

DE 19963201	A1	06-09-2001	NONE

FR 2204119	A	17-05-1974	NONE

DE 102005003573	A1	27-07-2006	AT 387127 T 15-03-2008
		DE 202005021357 U1	04-10-2007
		EP 1768524 A2	04-04-2007
		ES 2303330 T3	01-08-2008
		HR 20080217 T3	31-07-2008
		WO 2006087641 A2	24-08-2006
		US 2009014604 A1	15-01-2009
