

G. F. LYNCH,
Car Axle-Box.

No. 108,277

Patented Oct. 11, 1870.

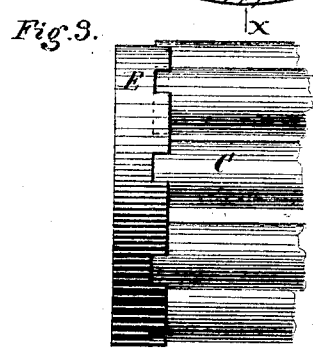
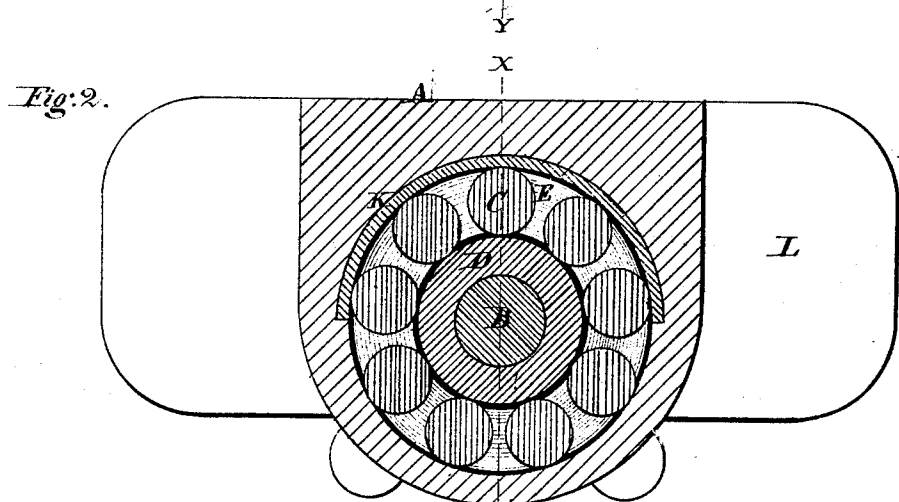
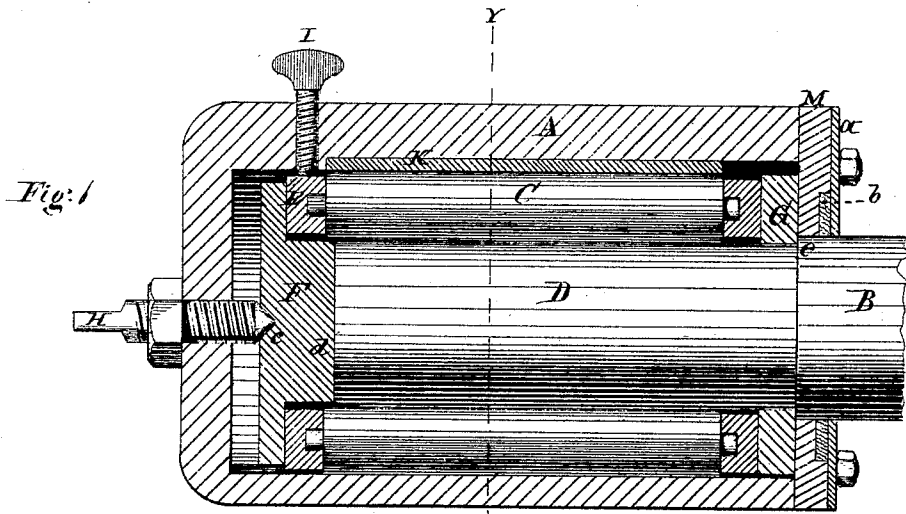

Witnesses:
P. T. Dodge
E. J. Sommer.

Inventor:
G. F. Lynch
by Dodge & Munn
his attys

G. F. LYNCH.

Car Axle Box.

No. 108,277.

Patented Oct. 11, 1870

Fig. 4.

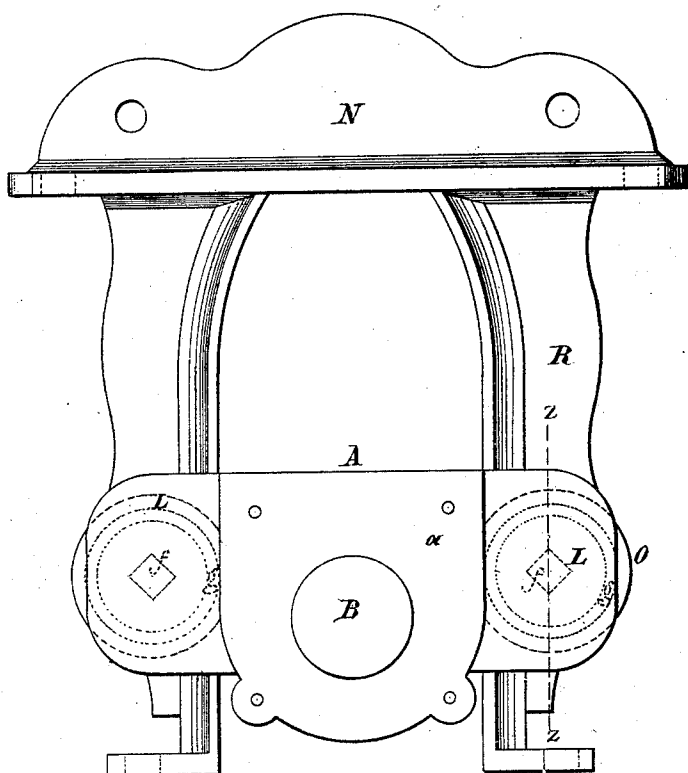
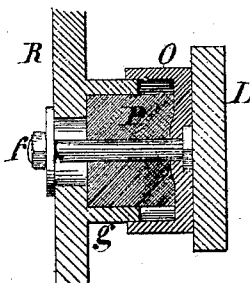

Fig. 5.



Witnesses:

D. T. Dodge
E. J. Sommers

Inventor:

G. F. Lynch
 by *Dodge & Munroe*
his attys.

United States Patent Office.

GEORGE F. LYNCH, OF MILWAUKEE, WISCONSIN.

Letters Patent No. 108,277, dated October 11, 1870.

IMPROVEMENT IN RAILWAY-CAR AXLE-BOXES.

The Schedule referred to in these Letters Patent and making part of the same.

To all whom it may concern:

Be it known that I, GEORGE F. LYNCH, of Milwaukee, in the county of Milwaukee and State of Wisconsin, have invented certain Improvements in Railroad-car Axle-Boxes, &c., of which the following is a specification, reference being had to the accompanying drawing.

My invention relates to car-axle boxes and their pedestals, and consists in certain improvements in their construction and arrangement, as hereinafter explained.

In the drawing—

Figure 1 is a longitudinal vertical section, on the line $x-x$ of fig. 2.

Figure 2 is a cross-section on the line $y-y$ of fig. 1.

Figure 3 is a side view of a part detached;

Figure 4 is an end view of the box and pedestal together; and

Figure 5 is a cross-section of a part on line $z-z$ of fig. 4.

In constructing my device, I make a metallic case, A, of any size desired, and, in its upper or bearing-surface, insert a steel or hardened metallic plate, K, as clearly shown in figs. 1 and 2, and in its inner end an annular head or washer, F, small enough to turn freely therein, on the pintle of a set-screw, H, which enters the center of the outer end of the case A, for that purpose, as shown in fig. 1.

This head or washer F has a conical hole or bearing, c , for the end of the set-screw H, and on its opposite side a collar, d , for a purpose hereinafter explained.

I then make two concentric ring-heads, E, with an equal number of annular holes in the opposite faces of each, the completed circumferences of which would extend a little beyond the outer and inner edges of the rings, the holes themselves extending inward only a short distance from the faces, and having, in the center of their bottoms, a smaller hole, and between these ring-heads, thus constructed, I mount or place a series of rollers, C, all as clearly shown in figs. 1, 2, and 3. The ring-heads E and rollers C, thus arranged, I place within the case A, as shown in figs. 1 and 2. These ring-heads E are made of the proper size, to allow the inner one to fit over and turn about the collar d , when necessary, and also to fit smoothly and bear against its shoulders, as shown in fig. 1, and also to allow the rollers to fill the cross-section of the interior of the case, as shown in both figs. 1 and 2.

Against the outer end or side of the outer ring-head I place another ring, G, so as to come within the mouth of the case; and, then, against this a plate, M, with an annular hole a little larger than the one in the ring G, and with an annular socket on its exterior side, in which I place a leather packing, b , and then cover the whole with another plate, a , having an an-

nular of the same size as that in the plate M, and bolt or screw the plates a and M fast to the end of the case, as shown in fig. 1.

That portion of the arm of the axle B that extends within the case A, beyond the plate M, I turn down, and fit snugly thereon a hardened metallic sleeve, D, for a bearing-surface for the rollers C, and have shoulder e , which bears against the outer face of the ring G, the inner end of the arm bearing against the face of the collar of the washer F, all as clearly shown in fig. 1.

In the upper side of the case is an opening for supplying lubricating material, which opening is closed by a screw, I, as shown in said fig. 1.

In a car-axle box constructed in this way, it will be seen that the washer F, ring-heads E, with their rollers C, and the ring G, are all held securely together by means of the screw H, and that if they should at any time, by wear or by any other means, run too loosely, they can at once be adjusted as desired by the same device. Should the lining K become worn, it can be removed and a new one substituted in its place, and the leather packing b between the plates a and M, which serves to keep out the dust and all foreign matter, can also be removed whenever necessary, and so with the sleeve D on the end of the axle, that can be removed and another substituted in its place, when desired.

In practical operation, the washer F, ring-heads E, with their rollers C, and the ring G, all turn with the axle, unless they get a little loose, from constant wear, or from some sudden jar, and thus, it will be seen that there will be but little friction in the operation of the box.

In connection with my box, thus constructed, I make a pedestal, N, with the opposite interior faces of its sides R perfectly smooth, as shown in fig. 5, and on the face of the sides R, looking toward the car, and about on a line with the axle, I make an annular projection, g , and provide it with a loosely-fitting cap O, and in this annular projection g I insert a rubber spring, P, thick enough to hold the top of the cap a little distance away from the top of the projection g , and then bolt the cap O and rubber P fast to the side N with bolt f , as clearly shown in fig. 5.

When the axle-box, provided with the ears L, is arranged to work in a pedestal, N, thus constructed, it will be seen that it will be free to move vertically and laterally at the same time, as it is not connected to the pedestal. Its lateral motion is limited by the rubber springs P, which serve to break the force of any sudden or violent movement toward the pedestal, and in this way protect both from injury. It is obvious that, instead of the lips I on the sides of the axle box, a stirrup may be used, hav-

ing its ends connected to the rubber springs on each side of the pedestal, and its bow or center to the outer end of the box; or that the rubber springs, instead of being connected to the sides of the pedestal, may be attached to the lips I of the box, so as to bear against the sides of the pedestal when the box moves toward them.

Having thus described my invention,

What I claim is—

1. The removable steel or hardened metallic lining K, in combination with a railroad-car axle-box, as herein shown and described, and for the purpose set forth.

2. In combination with a set-screw, H, or its equivalent, the head or washer-plate F, when provided with collar d and shoulders, as herein shown and described, for the purpose of bearing against the ring-head E and axle B, as set forth.

3. In combination with a pedestal and axle-box,

arranged, as herein described, to move independent of each other, the rubber springs P, whether attached to the pedestal or to the axle-box, as and for the purpose set forth.

4. The combination of the pedestal N with a car-axle box-case, provided with flanges L, a spring and friction-plate, when constructed and arranged substantially as herein described, and for the purpose set forth.

5. A car-axle box, consisting of the case A, with lining-plate K, set-screw H, plates a and M, with the intervening leather packing b, washer F, ring G, ring-heads E, and rollers O, all constructed and arranged to operate substantially as described.

G. F. LYNCH.

Witnesses:

H. B. MUNN,

PHIL. T. DODGE.