



US00RE43625E

(19) **United States**
(12) **Reissued Patent**
Kim et al.

(10) **Patent Number:** **US RE43,625 E**
(45) **Date of Reissued Patent:** **Sep. 4, 2012**

(54) **DRUM TYPE WASHING MACHINE**
(75) Inventors: **Na Eun Kim**, Seoul (KR); **Jin Woong Kim**, Seoul (KR); **Young Hwan Park**, Seoul (KR); **Jae Won Chang**, Gunpo-si (KR)

1,787,427 A 1/1931 Eckhard
2,089,066 A 8/1937 Morrill
2,096,649 A 10/1937 Rasanen
2,152,458 A 3/1939 Bergman
2,153,418 A 4/1939 Haberstump
2,165,884 A 7/1939 Chamberlin et al.
2,191,607 A 2/1940 Chamberlin et al.
2,217,351 A 10/1940 Soderquist

(73) Assignee: **LG Electronics Inc.**, Seoul (KR)

(Continued)

(21) Appl. No.: **13/116,059**

FOREIGN PATENT DOCUMENTS

(22) Filed: **May 26, 2011**

CN 2423308 Y 3/2001

(Continued)

Related U.S. Patent Documents

Reissue of:

(64) Patent No.: **7,536,882**
Issued: **May 26, 2009**
Appl. No.: **11/727,836**
Filed: **Mar. 28, 2007**

OTHER PUBLICATIONS

European Office Action dated Jul. 14, 2011 (Application No. 03013411.8).

(Continued)

(30) **Foreign Application Priority Data**

Mar. 29, 2006 (KR) 10-2006-0028358
Apr. 12, 2006 (KR) 10-2006-0033255

Primary Examiner — Frankie L Stinson
(74) *Attorney, Agent, or Firm* — KED & Associates LLP

(57)

ABSTRACT

(51) **Int. Cl.**
D06F 37/22 (2006.01)
(52) **U.S. Cl.** **68/24**; 68/140
(58) **Field of Classification Search** 68/14, 58,
68/140, 24
See application file for complete search history.

A drum type washing machine is provided, in which vibration is efficiently attenuated, by a maximum capacity within a size-fixed cabinet is provided, and by which a user does not bend over or sit down to load laundry into the washing machine. The drum type washing machine includes a cabinet forming an exterior of the drum type washing machine, a tub fixed within the cabinet, the tub having a laundry loading entrance at an outer circumference of the tub, a drum rotatably provided within the tub, the drum having an opening on a lateral side of the drum to communicate with the laundry loading entrance of the tub, a motor assembly provided next to one side of the drum to rotate the drum, and a suspension assembly provided to support a weight of the drum and attenuate vibration of the drum.

(56) **References Cited**

U.S. PATENT DOCUMENTS

912,038 A 2/1909 Seifert
1,077,043 A 10/1913 Darrow
1,470,245 A 10/1923 Slider
1,611,865 A 12/1926 Ahlm
1,611,895 A 12/1926 Dienner
1,657,181 A 1/1928 Sando

40 Claims, 10 Drawing Sheets

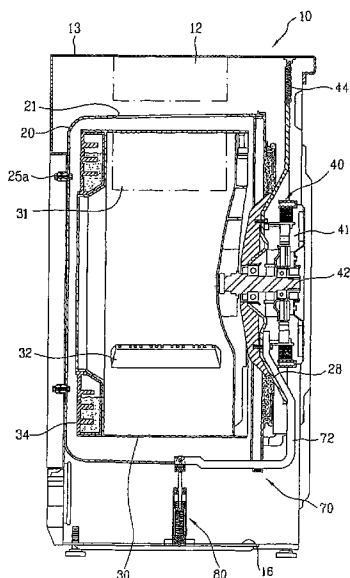

US RE43,625 E

U.S. PATENT DOCUMENTS							
2,230,345	A	2/1941	Bradbury	3,280,603	A	10/1966	Schwamm
2,278,911	A	4/1942	Breckenridge	3,333,444	A	8/1967	Bochan
2,296,257	A	9/1942	Breckenridge	3,356,222	A	12/1967	Belaieff
2,296,261	A	9/1942	Breckenridge et al.	3,362,198	A	1/1968	Barito
2,296,267	A	9/1942	Baird	3,389,881	A	6/1968	Stelwagen
2,323,765	A	7/1943	Haberstump	3,391,469	A	7/1968	Reeder
2,331,897	A	10/1943	Dyer	3,459,461	A	8/1969	Bannon, Jr.
2,356,816	A	8/1944	Breckenridge et al.	3,477,259	A	11/1969	Barnish et al.
2,356,818	A	8/1944	Bruckman	3,503,228	A	3/1970	Lake
2,389,774	A	11/1945	Haberstump	3,509,742	A	5/1970	Bauer
2,408,509	A	10/1946	Clark	3,531,954	A	10/1970	Krupsky
2,434,476	A	1/1948	Wales	3,742,738	A	7/1973	Frotriede
2,498,181	A	2/1950	Reiter	3,783,653	A	1/1974	Haerick
2,509,516	A	5/1950	Murphy	3,799,348	A	3/1974	Mazza
2,510,836	A	6/1950	Russell et al.	3,927,542	A	12/1975	de Hedouville et al.
2,521,578	A	9/1950	Haberstump	3,952,557	A	4/1976	Bochan
2,526,002	A	10/1950	Brotman	4,114,406	A	9/1978	Horowitz et al.
2,526,048	A	10/1950	Russell	4,295,387	A	10/1981	Zhivotov et al.
2,526,444	A	10/1950	Woodson	4,321,302	A	3/1982	Umeki et al.
2,527,239	A	10/1950	Woodson	4,412,390	A	11/1983	Grant
2,541,166	A	2/1951	Leef	4,437,325	A	3/1984	Hershberger
2,542,509	A	2/1951	Goriup	4,446,706	A	5/1984	Hartwig
2,555,269	A	5/1951	Chamberlin	4,498,181	A	2/1985	Menown et al.
2,556,490	A	6/1951	Chamberlin	4,618,193	A	10/1986	Cuthbert et al.
2,565,604	A	8/1951	Geiger	4,771,253	A	9/1988	Sasaki et al.
2,579,472	A	12/1951	Chamberlin et al.	4,819,460	A	4/1989	Obradovic
2,579,836	A	12/1951	Lee et al.	4,989,684	A	2/1991	Conaway
2,589,284	A	3/1952	O'Neil	5,038,586	A	8/1991	Nukaga et al.
2,593,752	A	4/1952	Haberstump	5,080,204	A	1/1992	Bauer et al.
2,615,320	A	10/1952	Belaieff	5,199,690	A	4/1993	Marshall
2,620,070	A	12/1952	Dodge	5,209,458	A	5/1993	Eubank et al.
2,629,245	A	2/1953	Chamberlin	5,230,229	A	7/1993	Stadelmann et al.
2,644,326	A	7/1953	Worst	5,267,456	A	12/1993	Nukaga et al.
2,652,708	A	9/1953	Rimsha et al.	5,280,660	A	1/1994	Pellerin et al.
2,656,700	A	10/1953	Smith	5,433,091	A	7/1995	Durazzani et al.
2,711,297	A	6/1955	Thiele	5,526,657	A	6/1996	Johnson
2,717,135	A	9/1955	Douglas	5,548,979	A	8/1996	Ryan et al.
2,737,799	A	3/1956	Knipmeyer	5,570,597	A	11/1996	Bongini et al.
2,757,531	A	8/1956	Fox	5,657,649	A	8/1997	Lim
2,758,685	A	8/1956	Sisson	5,678,430	A	10/1997	Merlin et al.
2,774,621	A	12/1956	Kilbourne, Jr.	5,711,170	A	1/1998	Johnson
2,785,557	A	3/1957	Stilwell, Jr.	5,711,171	A	1/1998	Uhlin
2,836,046	A	5/1958	Smith	5,768,730	A	6/1998	Matsumoto et al.
2,843,314	A	7/1958	Hansen	5,870,905	A	2/1999	Imamura et al.
2,844,225	A	7/1958	Hubbard et al.	5,907,880	A	6/1999	Durazzani et al.
2,859,877	A	11/1958	Sisson	5,913,951	A	6/1999	Herr et al.
2,873,599	A	2/1959	Buechler	5,924,312	A	7/1999	Vande Haar
2,882,706	A	4/1959	Brucken	5,961,105	A	10/1999	Ehrnsberger et al.
2,893,135	A	7/1959	Smith	5,979,195	A	11/1999	Bestell et al.
2,895,319	A	7/1959	Rochefort	6,032,494	A	3/2000	Tanigawa et al.
2,908,871	A	10/1959	McKay	6,122,843	A	9/2000	Noguchi et al.
2,930,217	A	3/1960	Rehmke	6,148,647	A	11/2000	Kabeya et al.
2,937,516	A	5/1960	Czaika	6,343,492	B1	2/2002	Seagar et al.
2,957,330	A	10/1960	Cline	6,363,756	B1	4/2002	Seagar et al.
2,959,966	A	11/1960	Bochan	6,460,382	B1	10/2002	Kim et al.
2,972,877	A	2/1961	Platt	6,474,114	B1	11/2002	Ito et al.
2,975,528	A	3/1961	Shewmon	6,477,867	B1	11/2002	Collecutt et al.
2,984,094	A	5/1961	Belaieff	6,481,035	B2	11/2002	Seagar et al.
2,986,914	A	6/1961	Brucken	6,510,715	B1	1/2003	Simsek et al.
2,987,189	A	6/1961	Evjen	6,510,716	B1	1/2003	Kim et al.
2,987,190	A	6/1961	Bochan	6,516,638	B1	2/2003	Myerscough
2,990,706	A	7/1961	Bochan	6,539,753	B1	4/2003	Ito et al.
2,995,023	A	8/1961	Douglas	6,557,383	B1	5/2003	Ito et al.
2,995,918	A	8/1961	Neidenthal et al.	6,564,594	B1	5/2003	Ito et al.
3,048,026	A	8/1962	Bochan et al.	6,578,225	B2	6/2003	Jönsson
3,058,331	A	10/1962	Anthony	6,578,391	B2	6/2003	Seagar et al.
3,066,522	A	12/1962	Steinmüller	6,612,138	B2	9/2003	Ryu et al.
3,073,668	A	1/1963	Rothenberger	6,626,014	B2	9/2003	Heyder et al.
3,089,326	A	5/1963	Belaieff	6,662,682	B2	12/2003	Stalsberg
3,098,581	A	7/1963	Marsilio	6,681,602	B2	1/2004	Heyder et al.
3,135,688	A	6/1964	Compans	6,782,722	B2	8/2004	Yokoi et al.
3,153,951	A	10/1964	Whelan	6,968,632	B2	11/2005	Guinibert et al.
3,178,916	A	4/1965	Belaieff et al.	6,981,395	B2	1/2006	Ryu et al.
3,197,983	A	8/1965	Ilmer	7,013,682	B2	3/2006	Sharrow
3,206,267	A	9/1965	Gruner et al.	7,065,905	B2	6/2006	Guinibert et al.
3,248,908	A	5/1966	Pope	7,073,356	B2	7/2006	Nakamura et al.
3,257,830	A	6/1966	Shelton	7,117,613	B2	10/2006	Guinibert et al.
3,273,361	A	9/1966	Smith	7,225,562	B2	6/2007	Guinibert et al.
				7,249,742	B2	7/2007	Guinibert et al.

US RE43,625 E

Page 3

7,257,905	B2	8/2007	Guinibert et al.	EP	0 725 179	B1	7/2000
7,334,799	B2	2/2008	O'Hara	EP	1 055 765	A1	11/2000
7,412,783	B2	8/2008	Guinibert et al.	EP	1 079 014	B1	2/2001
7,467,483	B2	12/2008	Guinibert et al.	EP	1 094 239	B1	4/2001
7,536,882	B2	5/2009	Kim et al.	EP	1 201 810		5/2002
7,762,007	B2	7/2010	Guinibert et al.	EP	1 386 996	B1	2/2004
7,841,220	B2	11/2010	Lim et al.	EP	1 433 890	B1	6/2004
2002/0000108	A1	1/2002	Heyder et al.	EP	1 433 891		6/2004
2002/0014095	A1	2/2002	Seagar et al.	EP	1 433 891	A2	6/2004
2002/0042957	A1	4/2002	Kim et al.	EP	1 455 011		9/2004
2002/0166349	A1	11/2002	Lim et al.	EP	1 505 191	A1	2/2005
2003/0056302	A1	3/2003	Broker et al.	EP	1 548 170		6/2005
2003/0061841	A1	4/2003	Nakamura et al.	EP	1 605 088	A2	12/2005
2004/0025544	A1	2/2004	Kim et al.	EP	1 619 286		1/2006
2004/0031295	A1	2/2004	Choi	EP	1 688 531	A1	8/2006
2004/0035155	A1	2/2004	Yoon	FR	2 230 782		1/1975
2004/0123631	A1	7/2004	Chang	FR	2 478 151		9/1981
2004/0129035	A1	7/2004	Chang	FR	2 511 401		2/1983
2004/0163425	A1	8/2004	Kim et al.	FR	2 610 017		7/1988
2004/0163428	A1	8/2004	Kim et al.	GB	646582		11/1950
2004/0237603	A1	12/2004	Kim et al.	GB	1120431		7/1968
2004/0244121	A1	12/2004	Lim et al.	GB	1 181 797		2/1970
2004/0244168	A1	12/2004	Lee	GB	1 270 950		4/1972
2004/0244438	A1	12/2004	North	GB	1 353 283		5/1974
2005/0028564	A1	2/2005	Lee et al.	GB	2 096 649	A	10/1982
2005/0188472	A1	9/2005	Park et al.	GB	2 157 326	A	10/1985
2005/0274159	A1	12/2005	Jeon et al.	GB	2 189 511	A	10/1987
2006/0010612	A1	1/2006	Kim et al.	GB	2 202 867	A	10/1988
2006/0011429	A1	1/2006	Park et al.	GB	2 360 296		9/2001
2006/0016228	A1	1/2006	Chang et al.	JP	39-21844	U	7/1962
2006/0254321	A1	11/2006	Lim et al.	JP	48-64179		8/1973
2007/0125135	A1	6/2007	Kim et al.	JP	49-135264		11/1974
2007/0227200	A1	10/2007	Kim et al.	JP	52-134264		11/1977
				JP	54-028470		3/1979
				JP	56-116987	A	9/1981
				JP	57-43792	A	3/1982
				JP	59-211496	A	11/1984
				JP	60-190998		9/1985
				JP	63-95587	U	6/1988
				JP	01-230390		9/1989
				JP	02-189188		7/1990
				JP	03-141988		6/1991
				JP	03-88479	U	9/1991
				JP	04-092697	A	3/1992
				JP	04-210091		7/1992
				JP	4-220291		8/1992
				JP	04-236988	A	8/1992
				JP	04-240488	A	8/1992
				JP	04-325196		11/1992
				JP	4-371194	*	12/1992
				JP	04-371194	A	12/1992
				JP	05-084388	A	4/1993
				JP	5-084389		4/1993
				JP	05-220293	A	8/1993
				JP	06-079087	A	3/1994
				JP	09-066185		3/1997
				JP	09-182368		7/1997
				JP	09-182370	A	7/1997
				JP	09-313780		12/1997
				JP	10-201993	A	8/1998
				JP	10-263265		10/1998
				JP	11-076680	A	3/1999
				JP	2000-262796	A	9/2000
				JP	2000-334194	A	12/2000
				JP	2002-153695	A	5/2002
				JP	2002-529173	T	9/2002
				JP	2002-346281	A	12/2002
				JP	2003-079995		3/2003
				JP	2003-230792	A	8/2003
				JP	2004-513721		5/2004
				JP	2004-188204		7/2004
				JP	2004-209255		7/2004
				JP	2005-198698		7/2005
				JP	2006-026408		2/2006
				JP	2006-034755		2/2006
				KR	10-1999-0066050	A	8/1999
				KR	10-1999-0079731	A	11/1999
				KR	10-2001-0009545	A	2/2001
				KR	10-2001-046776		6/2001

FOREIGN PATENT DOCUMENTS

CN	1293276	5/2001
CN	1332816	A 1/2002
CN	1511997	A 7/2004
CN	1515732	A 7/2004
CN	1550609	A 12/2004
CN	1614123	5/2005
DE	1 095 778	12/1960
DE	1 113 439	9/1961
DE	1 188 547	3/1965
DE	19 12 481	U 3/1965
DE	24 01 888	A1 7/1975
DE	24 54 489	A1 5/1976
DE	26 06 589	9/1976
DE	26 33 604	A1 2/1978
DE	27 32 684	* 2/1978
DE	27 32 684	A1 2/1978
DE	27 46 989	A1 4/1978
DE	31 09 641	A1 2/1982
DE	31 34 633	* 6/1982
DE	31 34 633	A1 8/1982
DE	34 37 835	* 5/1985
DE	34 37 835	A1 5/1985
DE	37 13 921	11/1988
DE	38 11 583	A1 10/1989
DE	39 07 258	A1 10/1989
DE	39 34 434	A1 4/1991
DE	42 39 504	A1 5/1994
DE	43 10 594	A1 10/1994
DE	4 426 900	2/1995
DE	43 30 079	A1 3/1995
DE	198 06 884	8/1999
DE	199 61 780	7/2001
EP	0 124 939	B1 11/1984
EP	0 132 805	A1 2/1985
EP	0 212 259	A2 3/1987
EP	0 272 949	B1 6/1988
EP	0 371 926	A1 6/1990
EP	0 405 068	B1 1/1991
EP	0 465 885	1/1992
EP	0 716 177	B1 6/1996
EP	0 750 064	A1 12/1996
EP	0 869 212	10/1998
EP	0 943 720	9/1999
EP	0 969 134	A1 1/2000

KR	10-2004-0011307	A	2/2004
KR	10-2004-0047223	A	6/2004
KR	10-2004-0058999	A	7/2004
KR	10-2006-0009075		1/2006
KR	10-2006-00028804	A	4/2006
SU	1181112	A	9/1986
SU	1615258		12/1990
SU	1663074	A1	7/1991
SU	1 703 740		1/1992
WO	WO 98/29595	A2	7/1998
WO	WO 99/35320		7/1999
WO	WO 03/012185		2/2003
WO	WO 03/097918	A2	11/2003
WO	WO 2005/071155		8/2005

OTHER PUBLICATIONS

U.S. Office Action dated Dec. 30, 2005 issued in U.S. Appl. No. 10/461,451.

U.S. Final Office Action dated Aug. 14, 2006 issued in U.S. Appl. No. 10/461,451.

U.S. Final Office Action dated Dec. 13, 2006 issued in U.S. Appl. No. 10/461,451.

U.S. Office Action dated Jan. 5, 2007 issued in U.S. Appl. No. 11/475,885.

U.S. Office Action dated Apr. 27, 2007 issued in U.S. Appl. No. 10/461,451.

U.S. Office Action dated Jun. 8, 2007 issued in U.S. Appl. No. 11/470,704.

U.S. Final Office Action dated Jul. 17, 2007 issued in U.S. Appl. No. 11/475,885.

European Search Report dated Aug. 20, 2007 issued in Application No. 07105198.1-2314.

U.S. Office Action dated Nov. 19, 2007 issued in U.S. Appl. No. 10/461,451.

U.S. Office Action dated Nov. 30, 2007 issued in U.S. Appl. No. 11/470,704.

U.S. Office Action dated Apr. 1, 2008 issued in U.S. Appl. No. 11/475,885.

U.S. Final Office Action dated May 15, 2008 issued in U.S. Appl. No. 11/470,704.

U.S. Final Office Action dated Jun. 16, 2008 issued in U.S. Appl. No. 10/461,451.

U.S. Office Action dated Sep. 5, 2008 issued in U.S. Appl. No. 11/165,332.

U.S. Office Action dated Sep. 11, 2008 issued in U.S. Appl. No. 11/470,704.

U.S. Final Office Action dated Feb. 25, 2009 issued in U.S. Appl. No. 11/165,332.

U.S. Office Action dated Feb. 25, 2009 issued in U.S. Appl. No. 12/198,269.

Japanese Office Action dated Mar. 2, 2009 issued in Application No. 2004-000478.

U.S. Office Action dated Sep. 21, 2009 issued in U.S. Appl. No. 12/267,457.

U.S. Final Office Action dated Oct. 14, 2009 issued in U.S. Appl. No. 12/198,269.

U.S. Office Action dated Oct. 15, 2009 issued in U.S. Appl. No. 11/529,759.

U.S. Office Action dated Oct. 28, 2009 issued in U.S. Appl. No. 12/230,031.

Japanese Office Action dated Dec. 18, 2009 issued in Application No. 2004-000478.

Chinese Office Action issued in CN Application No. 200710089087.4 dated Jan. 8, 2010.

U.S. Office Action dated Feb. 2, 2010 issued in U.S. Appl. No. 12/198,269.

European Search Report dated Feb. 3, 2010 issued in Application No. 09178918.0.

U.S. Final Office Action dated Mar. 5, 2010 issued in U.S. Appl. No. 12/267,457.

Chinese Office Action dated Mar. 8, 2010 issued in Application No. 200610142200.6.

U.S. Final Office Action dated Mar. 19, 2010 issued in U.S. Appl. No. 11/529,759.

Notice of Opposition dated May 7, 2010 filed in the European Patent Office for European Patent Application No. 05013603.5 (Publication No. EP 1 619 286 B1).

U.S. Final Office Action dated May 14, 2010 issued in U.S. Appl. No. 12/230,031.

Japanese Office Action issued in JP Application No. 2005-204374 dated Jul. 28, 2010.

Japanese Office Action issued in JP Application No. 2006-235745 dated Aug. 3, 2010.

U.S. Office Action dated Aug. 13, 2010 issued in U.S. Appl. No. 12/639,872.

Notice of Opposition and Opposition Brief filed in EP Application No. 03013411.8 dated Sep. 29, 2010 (Publication No. EP 1 433 890 B1) (Full German Text & English Translation).

U.S. Office Action issued in U.S. Appl. No. 12/797,758 dated Oct. 28, 2010.

European Search Report issued in EP Application No. 10012467 dated Nov. 25, 2010.

U.S. Office Action issued in U.S. Appl. No. 12/639,859 dated Dec. 9, 2010.

U.S. Office Action issued in U.S. Appl. No. 12/940,138 dated Dec. 16, 2010.

U.S. Office Action issued in U.S. Appl. No. 12/639,894 dated Dec. 23, 2010.

U.S. Office Action issued in U.S. Appl. No. 12/985,389 dated Mar. 16, 2011.

U.S. Office Action issued in U.S. Appl. No. 12/797,758 dated Mar. 17, 2011.

European Search Report issued in EP Application No. 10012465 dated Mar. 24, 2011.

European Search Report issued in EP Application No. 10012469 dated Apr. 8, 2011.

European Search Report issued in EP Application No. 10012470 dated Apr. 8, 2011.

U.S. Office Action issued in U.S. Appl. No. 12/940,096 dated Apr. 18, 2011.

U.S. Office Action issued in U.S. Appl. No. 12/639,859 dated Apr. 27, 2011.

European Search Report issued in EP Application No. 10012468 dated May 4, 2011.

U.S. Office Action issued in U.S. Appl. No. 12/940,138 dated May 20, 2011.

U.S. Final Office Action issued in U.S. Appl. No. 12/639,894 dated Aug. 3, 2011.

U.S. Final Office Action issued in U.S. Appl. No. 12/985,389 dated Aug. 8, 2011.

U.S. Final Office Action issued in U.S. Appl. No. 12/940,138 dated Sep. 8, 2011.

Office Action issued in U.S. Appl. No. 13/116,096 dated Nov. 29, 2011.

Office Action issued in U.S. Application No. 13/116,114 dated Nov. 29, 2011. (K1115RE.05).

Office Action issued in U.S. Appl. No. 13/116,077 dated Nov. 30, 2011.

Office Action issued in U.S. Appl. No. 13/116,089 dated Nov. 30, 2011.

Office Action issued in U.S. Appl. No. 13/116,159 dated Nov. 30, 2011.

Office Action issued in U.S. Appl. No. 13/116,147 dated Nov. 30, 2011.

Office Action issued in U.S. Appl. No. 13/116,105 dated Dec. 1, 2011.

U.S. Office Action issued in U.S. Appl. No. 13/241,348 dated Feb. 23, 2012.

U.S. Office Action issued in U.S. Appl. No. 13/239,424 dated Feb. 29, 2012.

U.S. Office Action issued in U.S. Appl. No. 13/241,411 dated Mar. 6, 2012.

U.S. Notice of Allowance issued in U.S. Appl. No. 13/239,445 dated Mar. 12, 2012.

US RE43,625 E

Page 5

U.S. Office Action issued in U.S. Appl. No. 13/239,427 dated Mar. 21, 2012.

U.S. Office Action issued in U.S. Appl. No. 13/241,337 dated Mar. 22, 2012.

U.S. Office Action issued in U.S. Appl. No. 13/239,416 dated Apr. 12, 2012.

U.S. Office Action issued in U.S. Appl. No. 13/116,089 dated Apr. 13, 2012.

U.S. Office Action issued in U.S. Appl. No. 13/116,077 dated Apr. 16, 2012.

U.S. Office Action issued in U.S. Appl. No. 13/116,096 dated Apr. 16, 2012.

U.S. Office Action issued in U.S. Appl. No. 13/116,159 dated Apr. 18, 2012.

U.S. Office Action issued in U.S. Appl. No. 13/116,114 dated Apr. 18, 2012.

European Office Action dated Dec. 7, 2011. (Application No. 10 012 465.0-2314).

Office Action issued in U.S. Appl. No. 13/241,366 dated Jan. 31, 2012.

Notice of Allowance issued in U.S. Appl. No. 13/239,439 dated Feb. 9, 2012.

Notice of Allowance issued in U.S. Appl. No. 13/239,448 dated Feb. 10, 2012.

Office Action issued in U.S. Appl. No. 13/241,366 dated Feb. 10, 2012.

U.S. Office Action issued in U.S. Appl. No. 13/239,430 dated May 4, 2012.

U.S. Office Action issued in U.S. Appl. No. 13/239,422 dated May 9, 2012.

U.S. Office Action issued in U.S. Appl. No. 13/241,348 dated Jun. 25, 2012.

U.S. Office Action issued in U.S. Appl. No. 13/241,366 dated Jun. 26, 2012.

U.S. Office Action issued in U.S. Appl. No. 13/241,396 dated Jun. 27, 2012.

European Patent Office 0 132 805 Feb. 1985.*

* cited by examiner

FIG. 1
Related Art

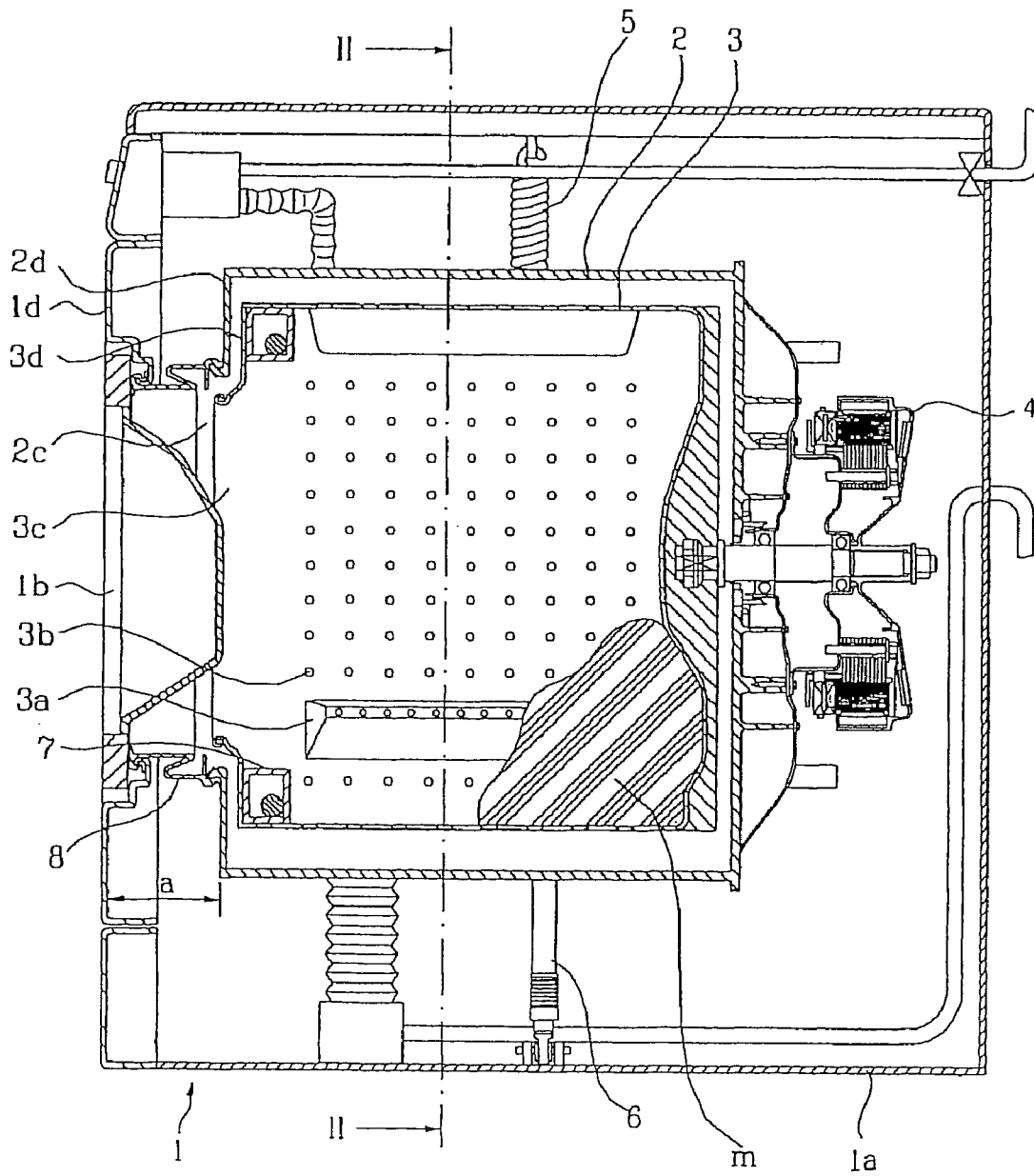

FIG. 2
Related Art

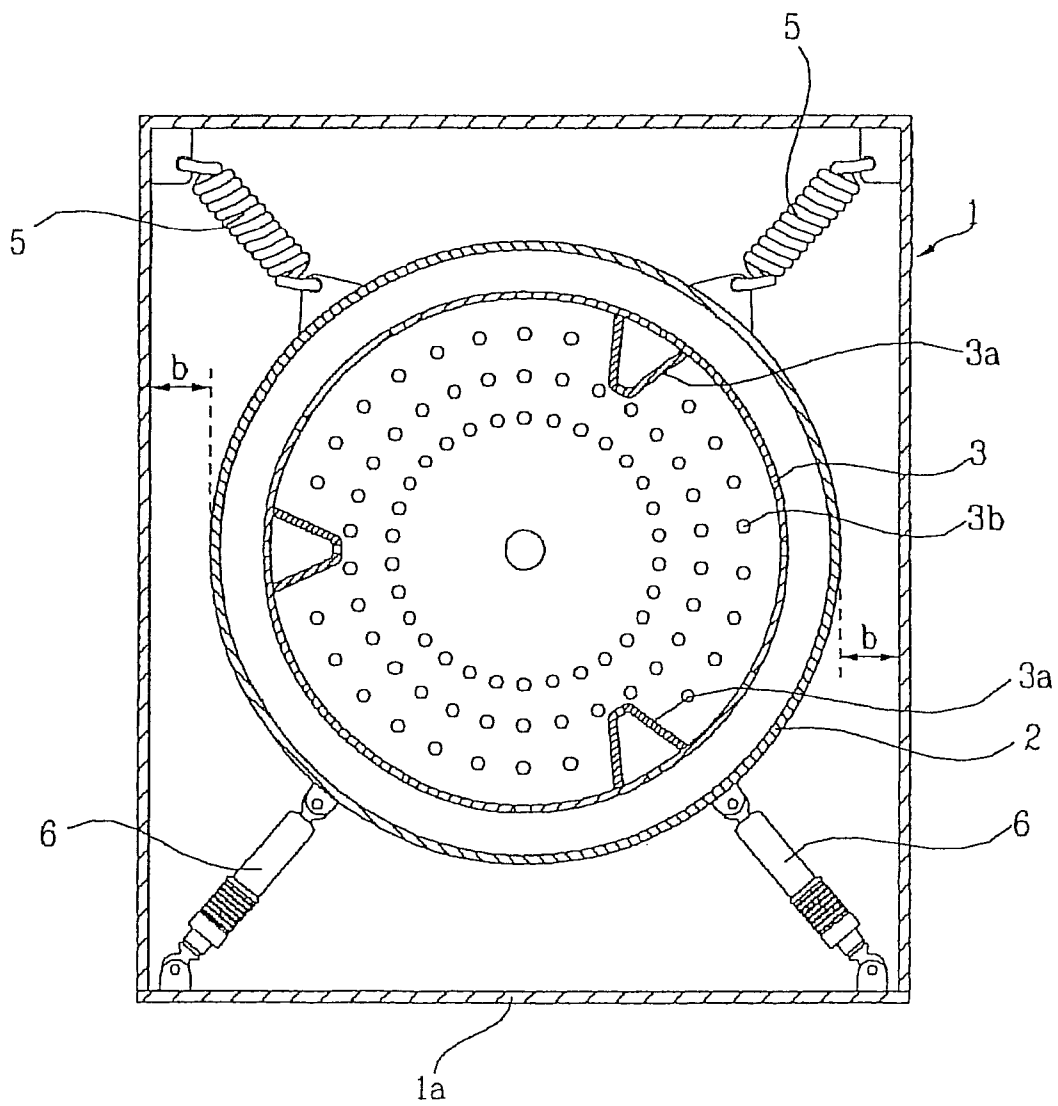

FIG. 3

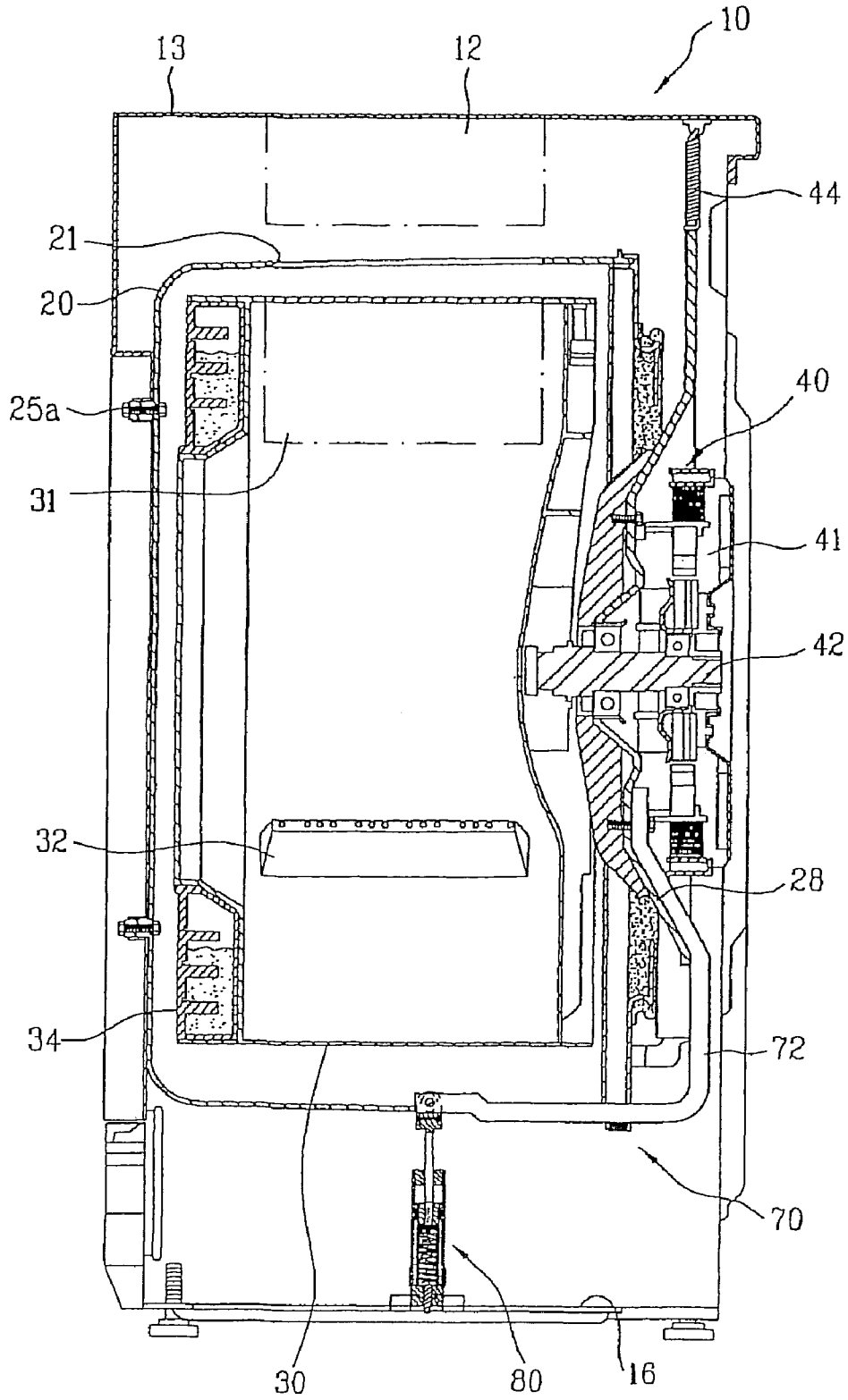

FIG. 4

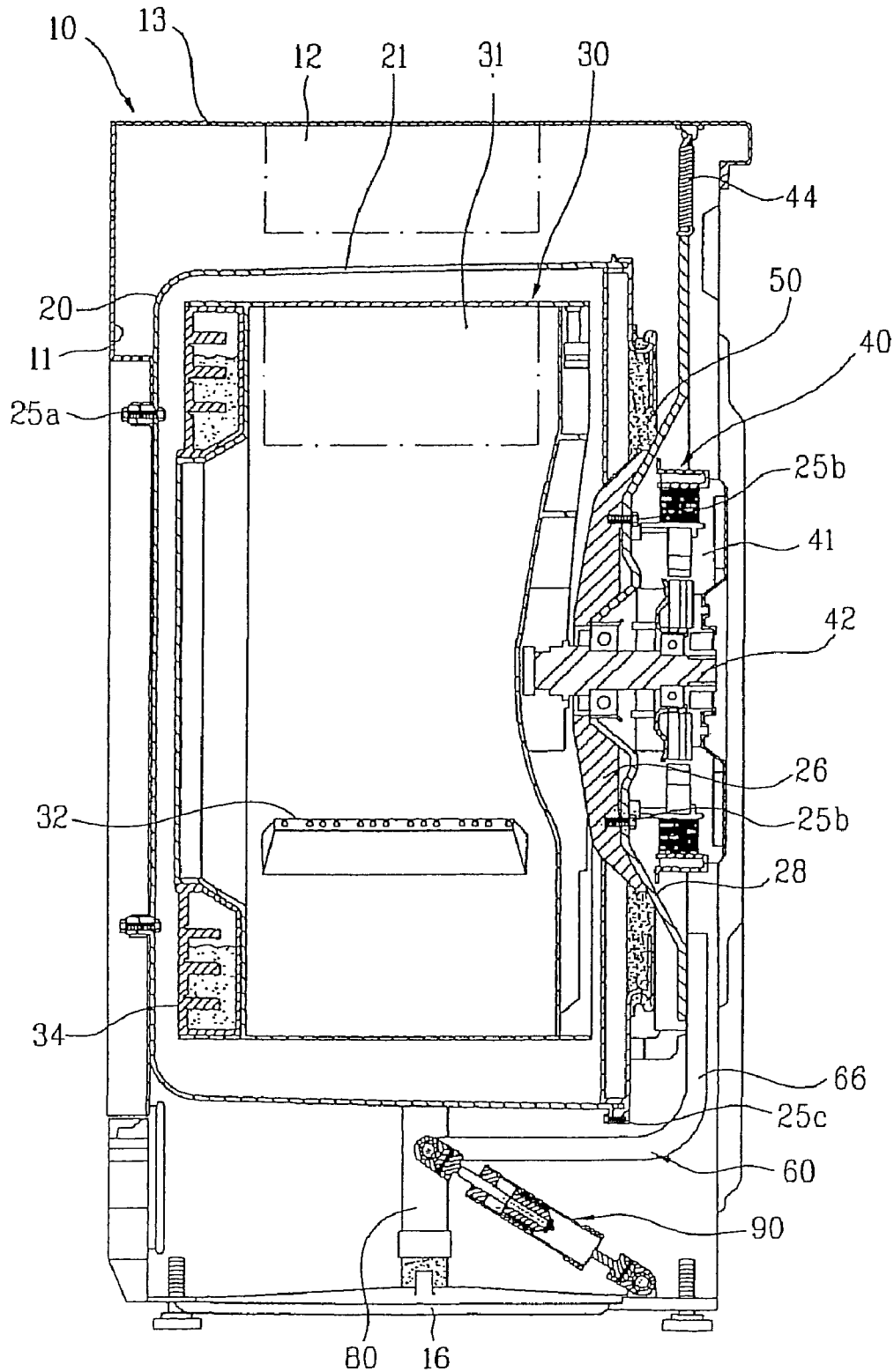

FIG. 5

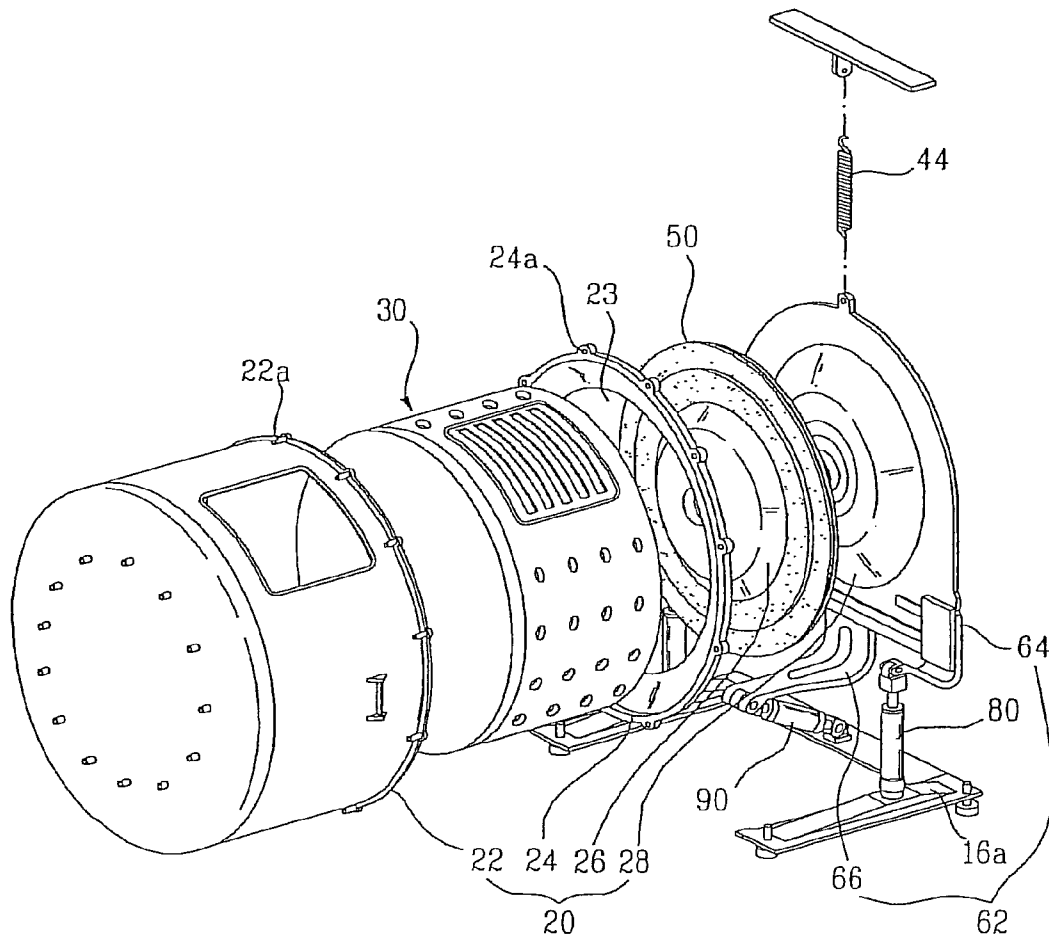
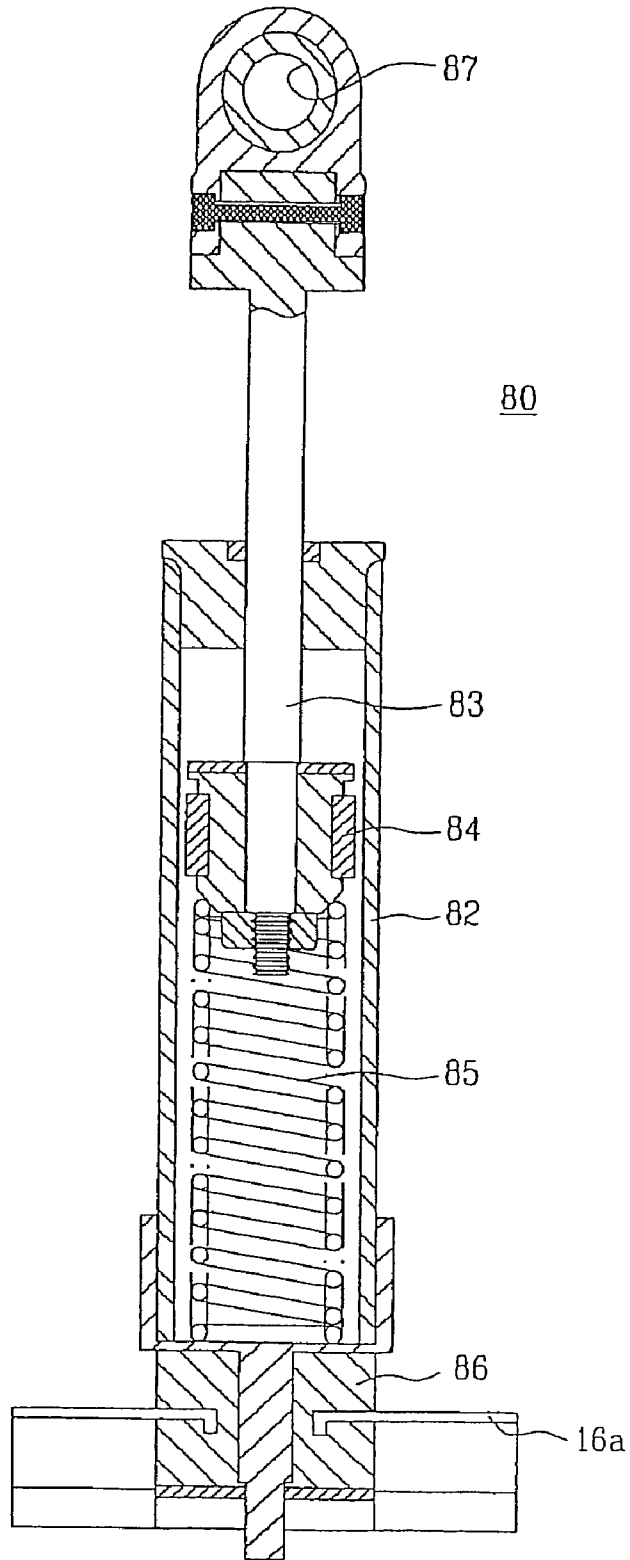

FIG. 6



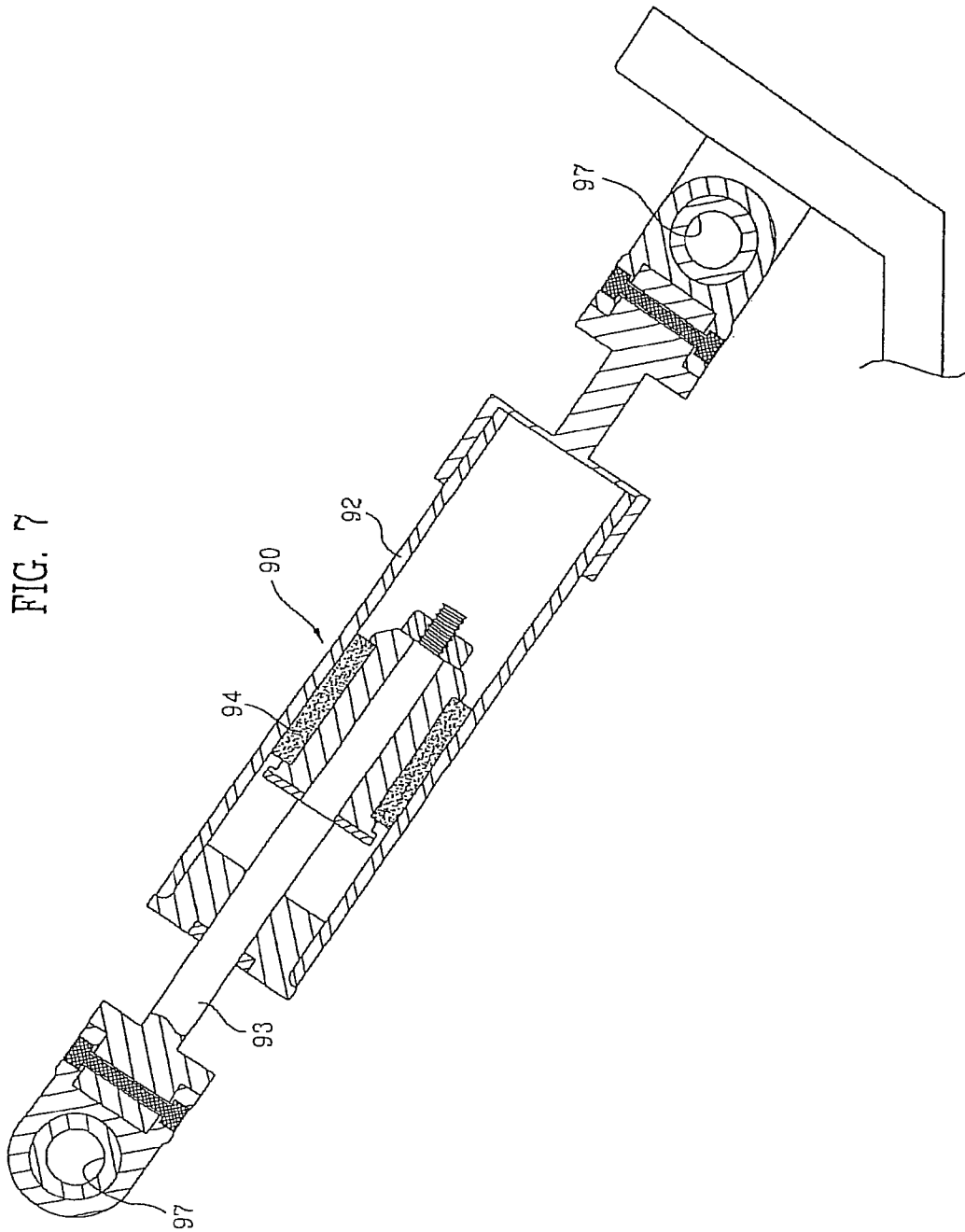

FIG. 8

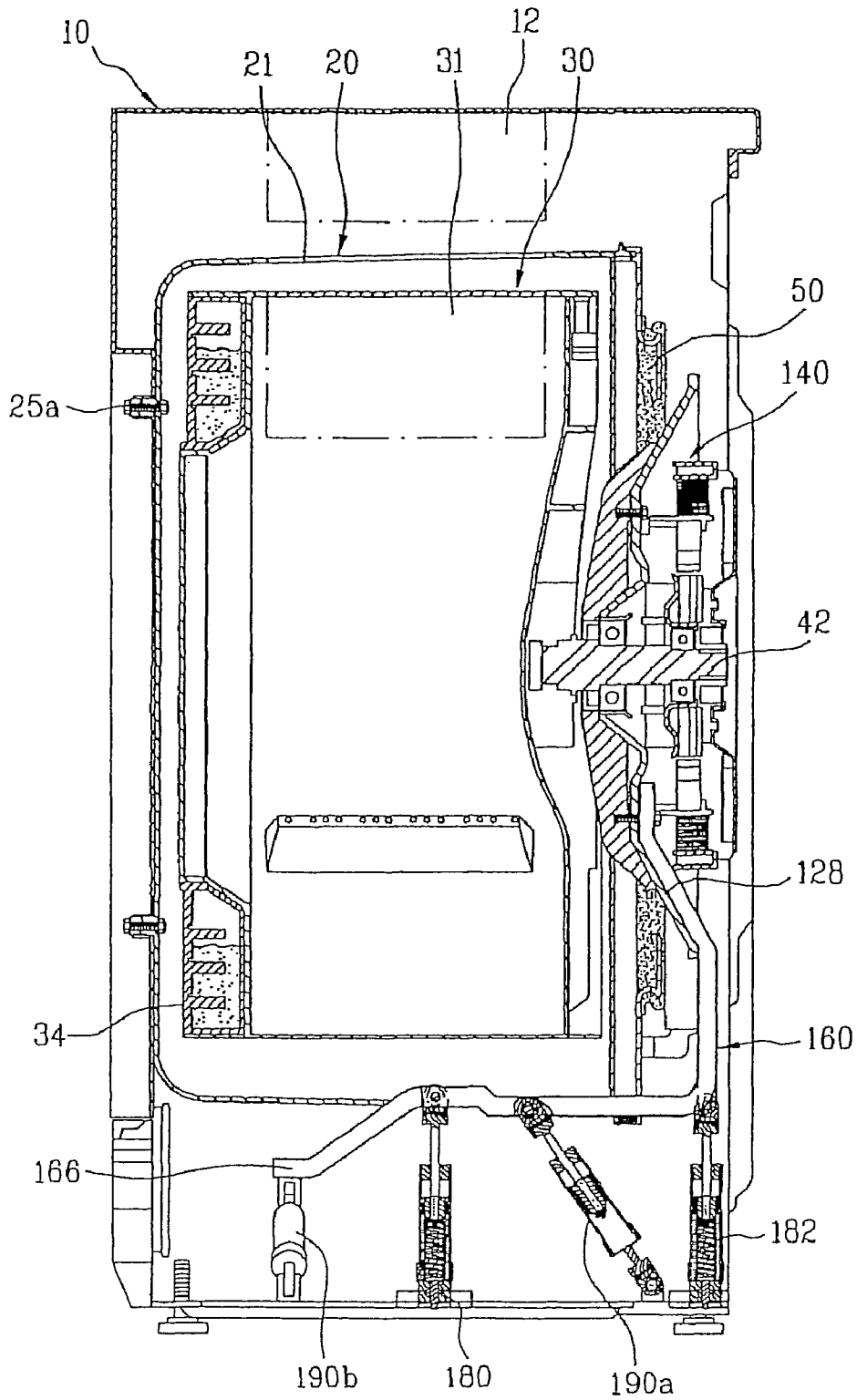

FIG. 9

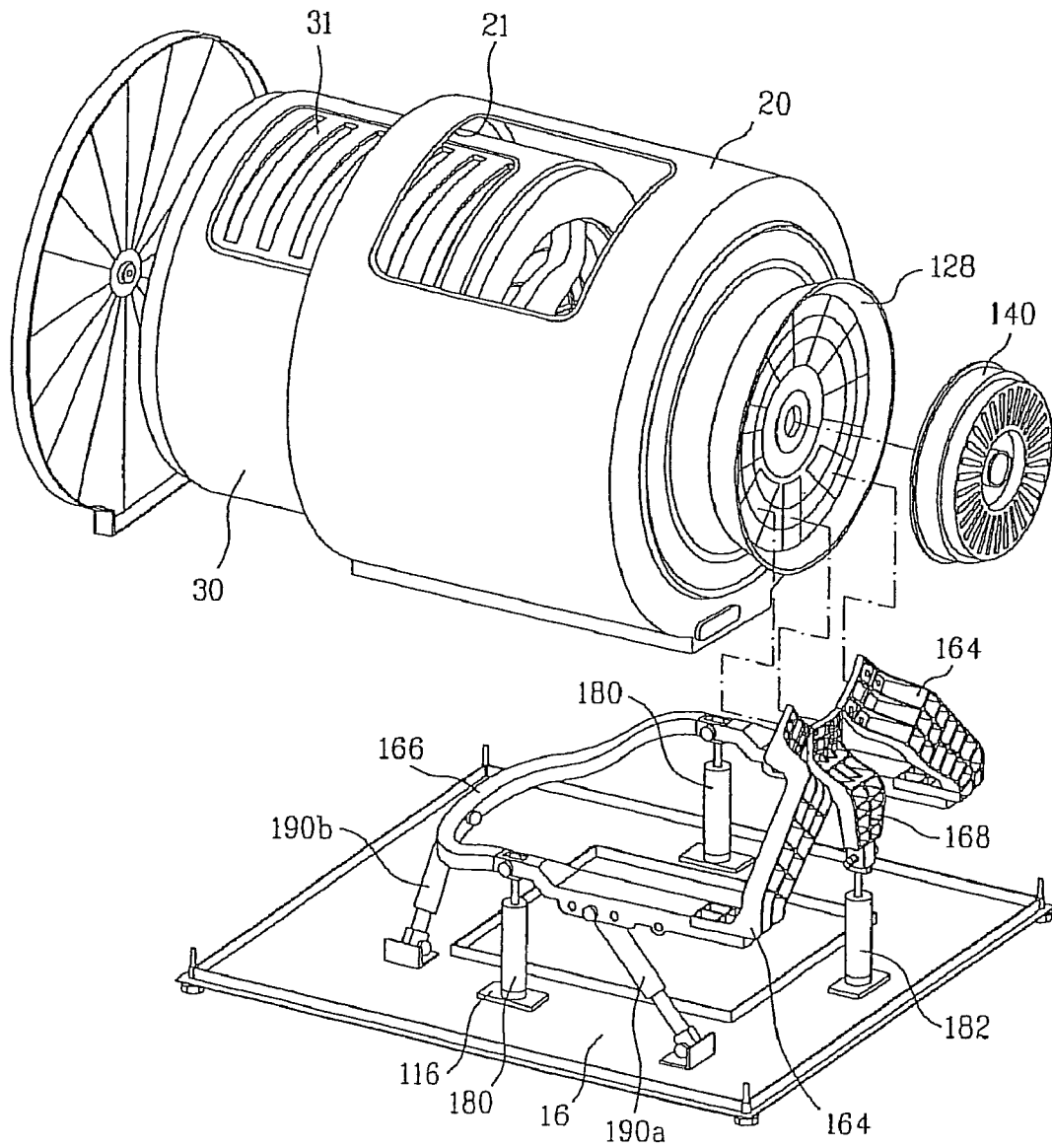
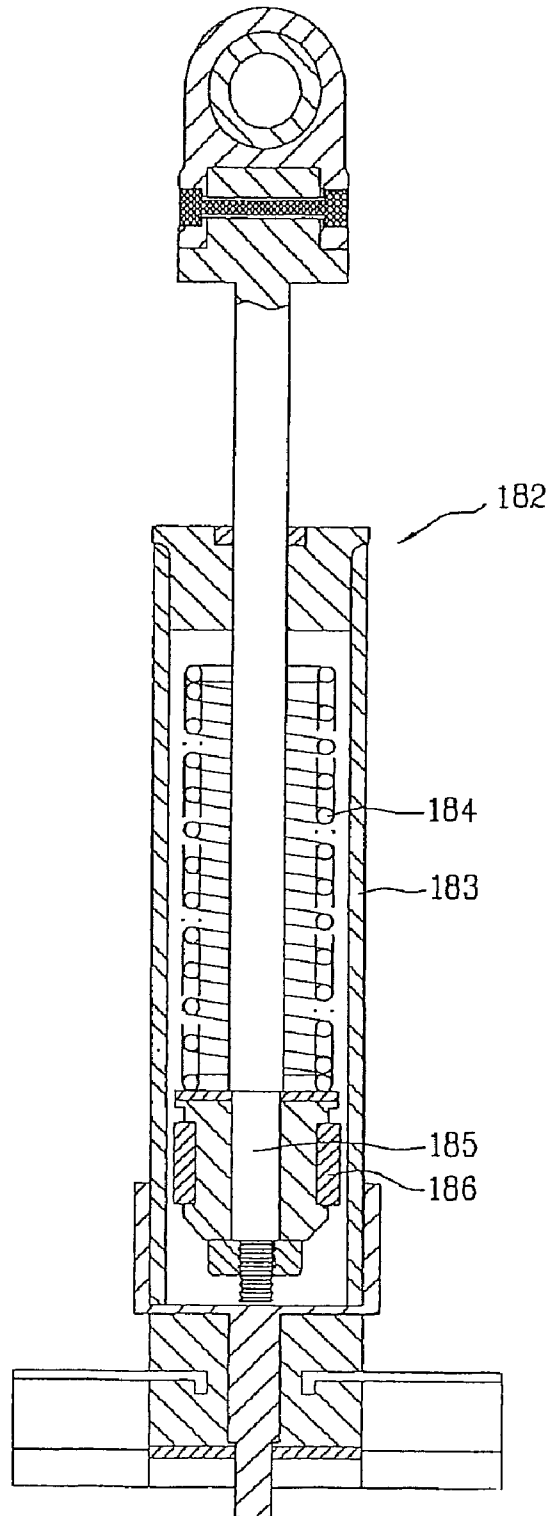

FIG. 10



DRUM TYPE WASHING MACHINE

Matter enclosed in heavy brackets [] appears in the original patent but forms no part of this reissue specification; matter printed in italics indicates the additions made by reissue.

More than one reissue application has been filed for the reissue of U.S. Pat. No. 7,536,882. The reissue applications are application Ser. Nos. 13/116,059 (the present application), 13/116,077, 13/116,089, 13/116,096, 13/116,105, 13/116,114, 13/116,147, and 13/116,159, all of which are divisional reissues of U.S. Pat. No. 7,536,882.

This application claims the benefit of the Korean Patent Application No. 10-2006-0028358, filed on Mar. 29, 2006, and Korean Patent Application No. 10-2006-0033255, filed on Apr. 12, 2006, which are hereby incorporated by reference for all purposes as if fully set forth herein.

BACKGROUND OF THE INVENTION

1. Field of the Invention

The present invention relates to a washing machine, and more particularly, to a drum type washing machine. Although the present invention is suitable for a wide scope of applications, it is particularly suitable for facilitating laundry to be loaded and unloaded from the washing machine with a maximum capacity within a predetermined volume.

2. Discussion of the Related Art

Generally, a drum type washing machine according to a related art has the following configuration.

FIG. 1 is a cross-sectional diagram of a drum type washing machine according to the related art, and FIG. 2 is a cross-sectional diagram according to a cutting line II-II shown in FIG. 1.

Referring to FIG. 1 and FIG. 2, a drum type washing machine according to the related art consists of a cabinet 1 having a base 1a and a door 1b, a tub 2 provided within the cabinet 1 to be fixed thereto, a drum 3 rotatably provided within the tub 2 to rotate laundry and water by a lift 3a, a motor 4 rotating the drum 3, and a spring 5, damper 6, and balancer 7 attenuating vibration transferred to the tub 2.

The drum 3 is provided with a multitude of holes 3b to enable water stored in the tub 2 to be introduced into the drum 3. The lift 3a is provided on an inner surface of the drum 3. The lift 3a is rotated together with the drum 3 to lift the laundry loaded within the drum 3 together with the water.

The tub 2 is provided to be spaced apart from inner lateral sides of the cabinet 1. Both sides of an upper end of the tub 2 are hung within the cabinet 1 via springs 5. The damper 6 is hinged between the tub 2 and the base 1a to be supported over the base 1a. And, the springs 5 and dampers 6 attenuate the vibration carried to the cabinet 1 from the tub 2.

The door 1b of the cabinet 1 is rotatably provided to a front side 1d of the cabinet 1 to enable the laundry to be loaded. Front sides 2d and 3d of the tub 2 and the drum 3 are provided with openings 2c and 3c to communicate with a hole (not shown in the drawings) opened by the door 1b, respectively.

A gasket 8 is provided between the front side 1d of the cabinet 1 having the door 1b assembled thereto and the front side 2d of the tub 2 to prevent leakage of the water. In particular, the gasket 8 seals the space between the inner lateral side of the cabinet 1 and the front side 2d of the tub 2.

And, the motor 4 is provided to a backside of the tub 2 to rotate the drum 3 provided within the tub 2.

However, the related art drum type washing machine has the following problems or disadvantages.

First of all, if vibration is generated from an inside of the drum 3 of the related art drum type washing machine due to the imbalance in washing or dewatering, both of the drum 3 and the tub 2 are shaken as one body. And, the springs and dampers 5 and 6 are configured to attenuate the vibration.

Since the tub 2 vibrates, the outer circumference of the tub 2 and the cabinet 1 should be sufficiently spaced apart from each other with a gap ('a' in FIG. 1 or 'b' in FIG. 2) to prevent the cabinet 1 and the tub 2 from colliding with each other. This restricts the capacity or volume of the tub 2 within the cabinet 1 having a fixed size.

Secondly, since the door 1b for loading and unloading the laundry and the openings 2c and 3c of the tub and drum are provided to face the front side of the washing machine, a user has to bend or sit down to load the laundry in the washing machine. This causes inconvenience to the user in using the washing machine.

SUMMARY

Accordingly, the present invention is directed to a drum type washing machine that substantially obviates one or more of the problems due to limitations and disadvantages of the related art.

An advantage of the present invention is to provide a drum type washing machine, by which vibration may be efficiently attenuated in a manner of providing a maximum capacity within a cabinet of fixed size.

Another advantage of the present invention is to provide a drum type washing machine, by which a user does not have to bend over or sit down to load laundry in the washing machine.

Additional advantages features of the invention will be set forth in the description which follows, and in part will be apparent from the description or may be learned from practice of the invention. The objectives and other advantages of the invention will be realized and attained by the structure particularly pointed out in the written description and claims hereof as well as the appended drawings.

To achieve these objects and other advantages and in accordance with the purpose of the invention, as embodied and broadly described herein, a drum type washing machine according to the present invention includes a cabinet forming an exterior of the drum type washing machine, a tub fixed within the cabinet, the tub having a laundry loading entrance at an outer circumference of the tub, a drum rotatably provided within the tub, the drum having an opening on a lateral side of the drum to communicate with the laundry loading entrance of the tub, a motor assembly provided next to one side of the drum to rotate the drum, and a suspension assembly provided to support a weight of the drum and attenuate vibration of the drum.

It is to be understood that both the foregoing general description and the following detailed description are exemplary and explanatory and should not be construed as limiting the scope of the claims.

BRIEF DESCRIPTION OF THE DRAWINGS

The accompanying drawings, which are included to provide a further understanding of the invention and are incorporated in and constitute a part of this specification illustrate embodiments of the invention and together with the description serve to explain the principles of the invention. In the drawings:

FIG. 1 is a cross-sectional diagram of a drum type washing machine according to a related art;

FIG. 2 is a cross-sectional diagram according to a cutting line II-II shown in FIG. 1;

FIG. 3 is a cross-sectional diagram of a drum type washing machine according to one embodiment of the present invention;

FIG. 4 is a cross-sectional diagram of a drum type washing machine according to another embodiment of the present invention;

FIG. 5 is an exploded perspective diagram of a tub, a drum and a suspension assembly of a drum type washing machine according to another embodiment of the present invention;

FIG. 6 is a cross-sectional diagram of a main damper shown in FIG. 5;

FIG. 7 is a cross-sectional diagram of a sub-damper shown in FIG. 5;

FIG. 8 is a cross-sectional diagram of a drum type washing machine according to a further embodiment of the present invention;

FIG. 9 is an exploded perspective diagram of a tub, a drum and a suspension assembly of a drum type washing machine according to a further embodiment of the present invention; and

FIG. 10 is a cross-sectional diagram of a rear damper shown in FIG. 9.

DETAILED DESCRIPTION

Reference will now be made in detail to an embodiment of the present invention, examples of which are illustrated in the accompanying drawings.

FIG. 3 is a cross-sectional diagram of a drum type washing machine according to one embodiment of the present invention.

Referring to FIG. 3, a drum type washing machine according to one embodiment of the present invention includes a cabinet 10 forming an exterior of the washing machine, a tub 20 fixed within the cabinet 10 to store water therein, a drum 30 rotatably provided within the tub 20, a motor assembly 40 providing a rotational force to the drum 30, and a suspension assembly 70 supporting a weight of the drum 30 and attenuating vibration of the drum 30.

In particular, the cabinet 10 forms the exterior of the drum type washing machine and includes a top cover 13 forming an upper side and a base 16.

Unlike the related art tub, the tub 20 of the present embodiment is fixed within the cabinet 10. That is, the tub 20 is directly assembled to an inner front side of the cabinet 10 of the washing machine, for example, via bolts. It should be appreciated, however, that the tub 20 may be fixed within the cabinet 10 in various ways.

A laundry loading entrance 21 is provided on an outer circumference of the tub 20 instead of being provided on the front side of the tub 20. Preferably, the laundry loading entrance 21 is provided to a position facing an upper side from a lateral side of the outer circumference to facilitate a user to load and unload the laundry. Alternatively, the laundry loading entrance 21 may be provided at another position of the outer circumference of the tub 20.

Optionally, a door 12 for loading the laundry may be provided to a position of the cabinet 10 to oppose the laundry loading entrance 21 of the tub 20.

A door assembly 31 may be provided to the drum 30 to communicate with the laundry loading entrance 21. Preferably, the laundry loading entrance 21 and the door assembly 31 are configured to be opened or closed if necessary.

Whenever the drum 30 of the drum type washing machine according to the present embodiment invention stops, it may always stop at a position where the door assembly 31 of the drum 30 and the laundry loading entrance 21 of the tub 20 may communicate with each other. Hence, a user is able to load the laundry in the drum 30 without bending over uncomfortably. And, the user is also able to look down on an inside of the drum 30, thereby enhancing the convenience in using the drum type washing machine.

The drum 30 is rotatably provided within the tub 20. The drum 30 is installed to be spaced apart from the tub 20 with a prescribed gap in-between to prevent a collision with the tub 20 due to vibration. And, at least one lift 32 may be provided to an inner circumference of the drum 30 to lift up the laundry.

The motor assembly 40 is provided on one side of the drum 30 to rotate the drum 30.

The motor assembly 40 includes a motor 41 generating a rotational force, a rotational shaft 42 transferring the rotational force of the motor 41 to the drum 30, and a bearing housing 28 rotatably supporting the rotational shaft 42.

Preferably, the motor assembly 40 is provided on one side of the drum 30 instead of being provided on both sides of the drum 30.

In particular, the rotational shaft 42 for rotating the drum 30 is provided on one side of the drum 30 only to maximize a volume within the drum 30.

The suspension assembly 70 is provided to support the weight of the drum 30 and attenuate the vibration of the drum 30.

Preferably, the suspension assembly 70 is configured to support the drum 30 by supporting the bearing housing 28.

As the drum 30 vibrates, so does the motor assembly 40. So, the suspension assembly 70 supports the bearing housing 28, thereby supporting the weight of the drum 30 and attenuating the vibration.

The above-configured suspension assembly 70 may include a damper bracket 72 extending from the bearing housing 28 and an attenuating part provided between the damper bracket 72 and the cabinet 10 to support the damper bracket 72 and attenuate the vibration simultaneously.

In the present embodiment, the attenuating part may include a damper 80 having one end connected to the damper bracket 72 and the other end connected to the base 16.

The damper bracket 72 may be configured to extend to each lower side of the outer circumference of the tub 20 from the bearing housing 28.

FIG. 3 shows the cross-section of the drum type washing machine according to one embodiment of the present invention.

And, the damper 80 of the drum type washing machine according to one embodiment of the present invention is preferably provided at a planar weight center between the entire elements (e.g., the drum 30, the motor assembly 40 for driving the drum 30, the damper bracket 72 assembled to the motor assembly 40, etc.) supported by the damper 80.

The above-configured damper 80 supports the weight of the drum 30, the weight of the motor assembly 40 for the rotation of the drum 30, and the like and plays a role in attenuating the vibration in a vertical direction. In the following description, the damper 80 attenuating the vertical vibration of the drum 30 is called a main damper 80.

And, the damper bracket 72 assembled to the main damper 80 to be supported by the main damper 80 shall be called a main damper bracket 72 in the following description.

FIG. 6 is a cross-sectional diagram of the main damper 80. Referring to FIG. 6, the main damper 80 preferably includes a cylinder 82, a piston 83 reciprocating within the

cylinder **82** according to vibration and motion of the drum **30**, and a spring **85** elastically supporting the piston **83**.

In this case, since the main damper **80** is provided between the main damper bracket **72** and the base **16** to support the weight of the drum **30** upwardly, a compressive weight is normally applied to the main damper **80**.

Therefore, it is preferable that the spring **85** is configured to generate an elastic force when the piston **83** enters the cylinder **82**.

A frictional member **84** is provided to the piston **82** to come into contact with an inner circumference of the cylinder **82**. When the drum **30** vibrates, the frictional member **84** may be configured to attenuate the vibration by making a motion of friction with the inner circumference of the cylinder **82** according to a motion of the piston **83**.

In particular, the weight applied to the main damper **80** is elastically supported by the spring **85** and the vibration transferred from the main damper **80** is attenuated by the frictional member **84**.

Preferably, one end of the main damper **80** joined to the main damper bracket **72** includes a hinge joint **87**, while the other end of the main damper **80** joined to the base **16** is configured to be fixed to the base **16** by an elastic material based rubber bushing **86**.

Since the main damper **80** is joined to the main damper bracket **72** by the hinge joint **87**, it may have a relative degree of freedom against a motion of the drum **30**. So, it is able to prevent the vibration or motion of the drum **30** from being directly carried to the cabinet **10**.

Both of the weight of the drum **30** and the weight of the motor assembly **40** for the rotation of the drum **30** are directly applied to the base **16** to which the main damper **80** is joined. To reinforce the base **16**, a reinforcing part for rigidity reinforcement may be provided to the portion of the base to which the main damper **80** is joined.

The reinforcing part may be provided by the curved portion ('16a' in FIG. 5) of the base **16** to which the main damper **80** is joined. Alternatively, the reinforcing part may include a separate bracket ('116' in FIG. 9).

Referring back to FIG. 3, to prevent the drum **30** from inclining to one side, an elastic member **44** may be further provided to elastically support the backside of the drum **30**. One end of the elastic member **44** is connected to an inner surface of the top cover **13** of the cabinet **10** and the other end of the elastic member **44** is connected to an upper side of the motor assembly **40**.

In particular, the elastic member **44** may include a spring. One end of the elastic member **44** is hung on the inner surface of the top cover **13** and the other end of the elastic member **44** is hooked on an upper end of the bearing housing **28**. Thus, the backside of the drum **30** is elastically hung on the top cover **13**, whereby the drum **30** is prevented from inclining to one side.

A user loads laundry into the drum **30** via the laundry loading entrance **21**, which is provided on the lateral side of the outer circumference of the tub **20**, and the door assembly **31**, which is provided on the lateral side of the outer circumference of the drum **30**, and then executes the corresponding washing.

Vibration is generated from the drum **30** in the course of washing and then attenuated by the main damper **80** through the main damper bracket **72**. Moreover, the front side of the tub **20** is directly assembled to the front inside of the cabinet **10** to be fixed thereto. So, if vibration or shock is delivered to the tub **20** assembled in one body to the cabinet **10**, the weight of the cabinet **10** itself being added to raise the rigidity of the tub **20** rather than the tub **20** itself is shaken by the vibration

or shock. Hence, it is able to enhance the overall vibration characteristics of the drum type washing machine.

Another embodiment of the present invention is explained as follows.

In the aforesaid embodiment of the present invention, the suspension assembly **70** supporting the drum **30** includes a pair of the main dampers **80**. Yet, in the present embodiment, a suspension assembly **70** may further include a sub-damper attenuating horizontal vibration of a drum **30**.

A drum type washing machine according to another embodiment of the present invention is shown in FIGS. 4 to 7.

In describing a drum type washing machine according to another embodiment of the present invention, the same names and reference numbers shall be used for the same parts of the former embodiment.

First of all, a drum type washing machine according to another embodiment of the present invention includes a cabinet **10** forming an exterior of the drum type washing machine, a tub **20** provided within the cabinet **10** to be directly assembled thereto, a drum **30** rotatably provided within the tub **20**, a motor assembly **40** provided in rear of the tub **20** to include a motor **41** rotating the drum **30**, a bearing housing **28** configuring a backside of the tub **20** to support the rotating shaft **42** of the motor **41**, a shock absorbing means **50** provided between the bearing housing **28** and the tub **20** for sealing an internal space of the tub **20** and for absorbing vibration or shock transferred to the tub **20** from the motor **40**, and a suspension assembly **60** supporting the drum to attenuate the vibration or shock transferred to the bearing housing **28**.

A door **12** is provided on a lateral outer circumference of the cabinet **10** instead of being provided on a front side of the cabinet **10**. And, a base **16** defines a bottom side of the cabinet **10**.

The tub **20**, as shown in FIG. 4, includes a tub body **22** directly assembled to an inside of a front side **11** of the cabinet **10**, the tub body **22** having a laundry loading entrance **21** at a lateral outer circumference to communicate with the door **12** of the cabinet **10**, a tub cover **24** assembled to a backside of the tub body **22** to enclose the drum **30**, the tub cover **24** having an opening **23** at its center, a tub bracket **26** closing the opening **23** of the tub cover **24**, and the bearing housing **28** assembled to a backside of the tub bracket **26** to configure the motor assembly rotating the drum, the bearing housing **28** configured to support the rotating shaft **42**.

The tub body **22**, as shown in FIG. 4 and FIG. 5, is fixed to the cabinet **10** by being locked to the inside of the front side of the cabinet **10** by screws **25a**. The tub cover **24** is assembled by accommodating the drum **30** therein. In particular, the tub cover **24** is assembled by being locked to the locking holes **22a** and **24a** on the outer circumferences of the tub body **22** and the tub cover **24** by screws **25c**. The opening **23** of the tub cover **24** is sealed by the tub bracket **26** and the shock absorbing means **50**. The bearing housing **28** is assembled to the backside of the tub bracket **26** by screws **25b**. In this case, the bearing housing **28** is provided with bearing (not shown in the drawings) to enable the rotational shaft **42** to be smoothly rotated and the rotational shaft **42** is supported by the bearing.

The shock absorbing means **50** is provided to absorb vibration or shock generated from the drum **30** and the motor **40** in performing washing or dewatering. The shock absorbing means **50** is formed of an elastic material that contracts or expands against the vibration or shock. And, the shock absorbing means **50** may include a backside gasket provided along an outer circumference of the tub bracket **26** to seal the opening **23**. In the present embodiment, the shock absorbing means **50** is implemented by the backside gasket that simul-

taneously achieves both a sealing function and a shock absorbing function between the tub cover **24** and the tub bracket **26**.

Alternatively, the shock absorbing means **50** may be individually configured according to each of the functions. In particular, a sealing member (not shown in the drawings) having the sealing function is inserted between the tub cover **24** and the tub bracket **26** and the shock absorbing means **50** is provided between the bearing housing **28** and the tub bracket **26**.

Hence, even if the vibration or shock is generated from the drum **30** or the motor assembly **40** joined to the drum **30**, since the shock absorbing means **50** is provided between the drum **30** and the tub **20**, the vibration or shock is delivered to the tub **20** after having been buffered via the shock absorbing means instead of being directly carried to the tub **20**. The vibration or shock delivered to the tub **20** is then attenuated or reduced by each rigidity and weight of the tub **20** and the cabinet **10**.

The motor **40** is assembled to the backside of the bearing housing **28**. The rotational shaft **42** of the motor **40** passes through both of the bearing housing **28** and the tub bracket **26** to be fixed to the backside of the drum **30**.

The drum **30** is rotated by the rotating shaft **42** of the motor **40**. And, at least one lift **32** is provided to an inner surface of the drum **30** to lift a laundry. And, a liquid balancer **34** is provided to a front side of the drum **30**. In this case, the liquid balancer **34** plays a role in balancing the drum **30** to suppress the vibration of the drum **30**.

The suspension assembly **60** is provided to support the weight of the drum **30** and attenuate the vibration of the drum **30**.

In the present embodiment, the suspension assembly **60** may include a damper bracket **62** extending from the bearing housing **28** and an attenuating part supporting the damper bracket **66** to support the drum **30**.

And, the attenuating part may include a pair of main dampers **80** supporting the weight of the drum **30** to attenuate the vertical vibration of the drum **30** and a sub-damper **90** attenuating the horizontal vibration of the drum **30**.

Moreover, the damper bracket **62** may include a pair of main damper brackets **64** joined to a pair of the main dampers **80**, respectively and a sub-damper bracket **66** joined to the sub-damper **90**.

In particular, the main damper bracket **64** joined to the main damper **80** is configured to have one end to be fixed to one of both lower corner of the bearing housing **28** and the other end bent toward a front side of the tub **20**. And, the main damper **80** is joined to the corresponding portion bent toward the front side of the tub **20**.

Preferably, the main damper **80** is installed vertical to the base **16**. This is because the main damper **80** supports the vertical weights of the drum **30**, bearing housing **28**, and motor **40** and also plays a role in attenuating the vertical vibration.

In particular, a pair of the main damper brackets **64** are provided to both of the lower corners of the bearing housing **28** toward the front side of the tub **20** and a pair of the main dampers **80** are joined to a pair of the main damper brackets **64**, respectively.

One end of the sub-damper bracket **66** joined to the sub-damper **90** is fixed to a center of a lower side of the bearing housing **28**, while the other end extends to a prescribed length toward the front side of the tub **20**. And, the sub-damper **90** is joined to the portion of the sub-damper bracket **66** extending toward the front side of the tub **20**.

In this case, the sub-damper **90** is configured to attenuate the horizontal vibration of the drum **30**. In particular, the

sub-damper **90** is preferably configured to incline a front to rear direction of the drum **30** to attenuate the front to rear direction vibration generated from over-vibration of the drum **30**.

Alternatively, the sub-damper **90** may be provided in a right to left direction to attenuate the right to left vibration.

Since the configuration of the main damper **80** is identical to that of the aforesaid main damper **80** of the former embodiment of the present invention, details of the main damper **80** are omitted in the following description.

FIG. 7 is a cross-sectional diagram of the sub-damper **90** according to an embodiment of the present invention.

Referring to FIG. 7, the sub-damper **90** includes a cylinder **92** having a hollow configuration, a piston **93** reciprocating within the cylinder **92** according to a motion of the drum **30**, and a frictional member **94** provided to the piston **93** to attenuate vibration energy by frictional movement against an inner surface of the cylinder **92**.

Preferably, the sub-damper **90** is provided between the sub-damper bracket **66** and the base **16** configuring the bottom side of the cabinet **10**. More preferably, both ends of the sub-damper **90** are joined by hinges **97** thereto.

Therefore, if the drum **30** vibrates back and forth, the sub-damper **90** contracts and expands in a direction of the vibration of the drum **30** to attenuate the corresponding vibration.

Similar to the former embodiment, the present embodiment may further include a reinforcing part provided a portion for joining the main damper **80** or the sub-damper **90** to the base **16** of the cabinet **10** to reinforce rigidity.

In this case, the reinforcing part may include a curved part **16a** provided to the portion for joining the main damper **80** or the sub-damper **90** to the cabinet **10** or a separate bracket ('116' in FIG. 9).

Referring to FIG. 4, an elastic member **44**, such as a coil spring, a string made of rubber and the like, may be provided to an inner surface of the top cover **13** forming a topside of the cabinet **10** to elastically hang the bearing housing **28**. In particular, the elastic member **44** elastically supports a rear portion of the drum **30** to prevent the drum **30** from inclining to one side.

Therefore, the vibration or shock generated from the drum **30** is transferred to the rotational shaft **42** of the motor connected to the drum **30** and the bearing housing **28** supporting the rotational shaft **42**. In this case, the transferred vibration or shock is primarily absorbed by the contraction or expansion of the shock absorbing means **50** and the rest of the vibration or shock is then delivered to the main dampers **80** and the sub-damper via the main damper brackets **64** and the sub-damper bracket **66**, respectively. So, the vibration or shock generated from the drum **30** may be reduced in a manner that the main dampers **80** attenuate the vertical vibration of the vibration delivered to the main dampers **80** and the sub-damper **90** while the sub-damper **90** attenuates the horizontal vibration of the vibration delivered to the main dampers **80** and the sub-damper **90**.

Hence, the horizontal vibration generated from the drum **30** is attenuated as well as the vertical vibration, whereby the drum **30** may be supported more stably.

A drum type washing machine according to a further embodiment of the present invention is explained as follows.

FIGS. 8 to 10 are diagram of a drum type washing machine according to a further embodiment of the present invention.

In describing a drum type washing machine according to a further embodiment of the present invention, the same names and reference numbers shall be used for the same parts of the former embodiment.

Referring to FIGS. 8 to 10, a drum type washing machine according to a further embodiment of the present invention includes a cabinet 10 defining an exterior of the drum type washing machine, a tub 20 fixed within the cabinet 10 to store water therein, a drum 30 rotatably provided within the tub 20, a motor assembly 140 provided next to one side of the drum 30 to rotate the drum 30, and a suspension assembly 160 provided to support a weight of the drum 30 and attenuate vibration of the drum 30.

A laundry loading entrance 21 is provided to an outer circumference of the tub 20 to load and unload laundry. And, a door assembly 31 is provided to a specific portion of the drum 30 to communicate with the laundry loading entrance 21.

Moreover, a door 12 may be provided to a specific portion of the cabinet to communicate with the laundry loading entrance 21.

Since the cabinet 10, the tub 20, the drum 30 and the motor assembly 140 of the drum type washing machine according to the further embodiment of the present invention are identical to those of the drum type washing machine according to the former embodiment of the present invention, the corresponding descriptions are referred to in the previous description for convenience of explanation.

Meanwhile, the suspension assembly 160 of the drum type washing machine according to the further embodiment of the present invention includes a damper bracket joined to the bearing housing 128 and an attenuating part joined to the damper bracket to attenuate vibration. In this case, the attenuating part supports a weight of the drum 30 and a weight of the motor assembly 140 driving the drum 30.

The attenuating part may include a main damper 180 supporting the weight of the drum 30 to attenuate vertical vibration and a rear damper 182 attenuating the vertical vibration of the drum to prevent the drum 30 from inclining to one side.

And, the damper bracket may include at least one main damper bracket 164 joined to the main damper 180 and a rear damper bracket 168 joined to the rear damper 182.

Preferably, the at least one main damper bracket 164 joined to the main damper 180 extends from the bearing housing 128 to an outside of an outer circumference of the tub 20 toward each lower lateral side of the tub 20 in a direction of a diameter of the tub 20 and then extends toward a front side of the tub 20 to a prescribed length. And, the main damper 180 is preferably joined to an end portion of the extending portion of the main damper bracket 164.

Preferably, the main damper 180 is provided vertical to the base 16. This is because the main damper 180 plays a role in supporting vertical weights of the drum 30, bearing housing 128 and motor assembly 140 and attenuating the vertical vibration.

In particular, a pair of main damper brackets 164 are provided to extend from both lateral sides of the bearing housing 128 toward the front side of the tub 20, respectively. And, a pair of main dampers 180 are provided to be joined to a pair of the main damper brackets 164, respectively.

Since each of the above-configured main dampers 180 has the same configuration of the aforesaid main damper 80 of the former embodiment of the present invention, its details are omitted in the following description.

Preferably, one end of the rear damper bracket 168 joined to the rear damper 182 is fixed to a lower center of the bearing housing 128 and the other end is configured to extend to a prescribed length toward the base 16. And, the rear damper 182 is vertically joined to an end portion of the other end of the rear damper bracket 168.

FIG. 8 is a cross-sectional diagram of a drum type washing machine according to a further embodiment of the present invention. For convenience of explanation, the main damper bracket 164 is represented as a perspective diagram instead of a cross-sectional diagram.

The main damper 180, as shown in FIG. 9, is provided under each of both of the lower sides of the drum 30 and the rear damper 182 is provided under a rear side of the drum 30. In this case, since a pair of the main dampers 180 are provided under both of the lower sides of the drum 30, the pair of main dampers 180 and the rear damper 182 are provided to configure a triangle.

Namely, three dampers are provided to attenuate the vertical vibration of the drum 30.

The rear damper 182 is the element that prevents the drum 30 from inclining to a front or rear side of the drum 30. Generally, the drum 30 tends to incline to one side owing to a center of weight. Since the heavy motor assembly 140 is normally provided next to the backside of the drum 30, the center of weight of the drum 30 lies in a rear part of the drum 30 rather than a central part of the drum 30 when the drum 30 is empty.

Hence, a pair of the main dampers 180 and the rear damper 182 prevent the drum 30 from drooping while supporting the weight of the drum 30.

In this case, the function and configuration of the rear damper 182 may vary according to an installed position of the corresponding main damper 180.

In particular, if the main damper 180 is provided to a position enabling the empty drum 30 to keep its balance, when laundry and water are loaded in the drum 30, the drum 30 inclines forward while a rear side of the drum 30 relatively rises upward.

In this case, the rear damper 182, as shown in FIG. 10, preferably includes a cylinder 183, a piston 185 reciprocating within the cylinder 183 to attenuate vibration, a frictional member 186 attached to the piston 185, and a spring 184 supporting the piston 185 to provide an elastic force when the piston 185 is pulled out, thereby elastically pulling down the rear side of the drum 30 not to rise. Alternatively, the rear damper 182 may be configured identical to that shown in FIG. 6 to provide an elastic force when the spring 85 is pulled.

If the rear side of the drum 30 is designed to fall when laundry and water are loaded in the empty drum 30 tending to incline backward, the rear damper 182, as shown in FIG. 6, preferably includes the cylinder 82, the piston 83 reciprocating within the cylinder 82 to attenuate vibration, and the spring 85 supporting the piston 83 to activate an elastic force when the piston 83 enters the cylinder 82. In particular, the rear damper 182 elastically supports the rear side of the drum 30 to prevent the rear side of the drum 30 from falling downward.

In this case, positions for installing the main dampers 180 and the rear damper 182 are preferably decided to enable a center of weight working by the drum 30, the motor assembly 140, and the like to exist within the triangle configured by the main dampers 180 and the rear damper 182.

Although the other end portions of the side for joining the main damper brackets 164 of the main dampers 180 and the rear damper 182 and the sub-damper bracket 166 thereto may be directly joined to the base 16, the forming parts ('16a' in FIG. 5) or the reinforcing plates 116 of the former embodiments may be provided to prevent the transformation of the base 16.

Meanwhile, the suspension assembly of the present embodiment may further include sub-dampers 190a and 190b attenuating the horizontal vibration of the drum 30 in addition

to the main dampers **180** and the rear damper **182** that attenuate the vertical vibration by supporting the weight of the drum **30**.

The horizontal vibration of the drum **30** includes a front-to-rear vibration of the drum **30** and a right-to-left vibration of the drum **30**. And, the horizontal vibration tends to be generated in case that the drum **30** is in an over-vibrating state.

To attenuate the horizontal vibration, the sub-dampers **190a** and **190b** may be provided to incline in a front-to-rear or right-to-left direction.

In particular, if the sub-damper **190a** is provided to incline in the front-to-rear direction, the front-to-rear horizontal vibration of the drum **30** will be attenuated. If the sub-damper **190b** is provided to incline in the right-to-left direction, the right-to-left horizontal vibration of the drum **30** will be attenuated.

Of course, either the sub-damper **190a** or the sub-damper **190b** may be selectively provided to incline in either the front-to-rear direction or the right-to-left direction. Alternatively, both of the sub-dampers **190a** and **190b** may be provided to incline in the front-to-rear direction and the right-to-left direction, respectively.

Preferably, one end of the sub-dampers **190a** and **190b** are hinged to one side of the main damper bracket **164** and the other end of the sub-dampers **190a** and **190b** are hinged to the base **16**.

A sub-damper bracket **166** joined to the sub-dampers **190a** and **190b** may be separately provided. The sub-damper bracket **166** may be configured to be joined to the main damper bracket **164**. Alternatively, the sub-damper bracket (not shown in the drawing) may be configured to be directly joined to the bearing housing **128**.

The above-configured sub-dampers **190a** and **190b** may have the same configurations of the aforesaid sub-dampers **190a** and **190b** of the former embodiment of the present invention.

In the drum type washing machine according to the further embodiment of the present invention, since the tub **20** is directly fixed to the cabinet **10** so as not to fluctuate, the tub **20** may avoid colliding with the cabinet **10**. Hence, a diameter of the tub **20** may be increased to extend a capacity or volume of the drum **30**.

Since one side of the rotating drum **30** is supported instead of both sides of the rotating drum **30**, an internal volume of the drum **30** may be further extended and the number of parts may be reduced. Hence, productivity may be enhanced.

Since the drum **30** is supported by three points using the main dampers **180** and the rear damper **182**, the drum **30** may be prevented from inclining to one side according to the variation of the center of weight attributed to the loaded laundry and water.

Since the sub-dampers **190a** and **190b** are provided to attenuate the front-to-rear and right-to-rear directional vibrations, it is able to effectively suppress the horizontal vibration of the drum **30**.

Accordingly, the embodiment of the present invention provides the following effects or advantages.

First of all, since a tub is directly fixed to a cabinet so as not to fluctuate, it is able to increase a diameter of the tub. Hence, a volume or capacity of a drum may be considerably increased.

Secondly, since a laundry loading entrance and a door assembly are provided on a lateral side of an outer circumference of a drum to load and unload laundry in the drum instead of a front side of the drum, a user does not bend over to load the laundry in the drum and is able to conveniently

look down on an inside of the drum. Hence, the present invention enhances user's convenience.

Thirdly, a rotational shaft and a motor assembly to rotate a drum are provided to one side of the drum only and one side of the drum is supported only. So, it is unnecessary to support both ends of the drum. Hence, a volume or capacity of the drum may be increased.

Fourthly, a front side of a tub is directly joined and fixed to an inner surface of a front side of a cabinet. In case that vibration or shock is delivered to the tub assembled in one body of the cabinet, a weight of the cabinet is added to increase rigidity of the tub rather than the tub shaking because of the vibration or shock. Hence, an overall vibration characteristic of a drum type washing machine may be enhanced.

It will be apparent to those skilled in the art that various modifications and variations may be made without departing from the spirit or scope of the inventions. Thus, it is intended that the claims cover the modifications and variations of this invention provided they come within the scope of the claims and their equivalents.

What is claimed is:

1. A drum type washing machine comprising:

a cabinet forming an exterior of the drum type washing machine;

a tub fixed within the cabinet, the tub defining a space where water for washing laundry is held and having a laundry loading entrance at an outer circumference of the tub;

a drum rotatably provided within the space of the tub, the drum having an opening on a lateral circumferential side thereof to communicate with the laundry loading entrance of the tub;

a motor assembly provided next to one side of the drum to rotate the drum the motor assembly including a rotational shaft connected to the drum;

a plate through which the rotational shaft passes, the plate covering part of the space of the tub;

a gasket connected between the tub and the plate, the gasket covering part of the space of the tub therebetween; and a suspension assembly provided to support a weight of the drum and attenuate vibration of the drum.

2. The drum type washing machine of claim 1, the motor assembly comprising:

a motor generating a rotational force; and

a bearing housing rotatably supporting the rotational shaft, and the suspension assembly comprising:

at least one damper bracket extending from the bearing housing; and

an attenuating part provided between the at least one damper bracket and the cabinet to support the drum via the at least one damper bracket.

3. The drum type washing machine of claim 2, the attenuating part comprising a pair of main dampers provided to support the weight of the drum and attenuate vertical vibration of the drum.

4. The drum type washing machine of claim 3, the attenuating part further comprising a sub-damper provided to attenuate horizontal vibration of the drum.

5. The drum type washing machine of claim 4, wherein the at least one damper bracket is configured to be bent toward a front side of the tub from a center of the bearing housing and wherein one end of the sub-damper is joined to an end portion of the at least one damper bracket.

6. The drum type washing machine of claim 4, wherein the sub-damper is connected to both of the at least one damper bracket and the cabinet.

13

7. The drum type washing machine of claim 3, the attenuating part further comprising an elastic member connecting the bearing housing on a topside of the cabinet.

8. The drum type washing machine of claim 3, the at least two main dampers, each comprising:

a cylinder;

a piston provided to reciprocate within the cylinder according to a motion of the drum to attenuate the vibration of the drum; and

a spring configured to elastically support the piston.

9. The drum type washing machine of claim 8, wherein a frictional member is provided to an outer circumference of the piston to attenuate the vibration by making a frictional movement against an inner circumference of the cylinder according to a motion of the piston.

10. The drum type washing machine of claim 8, wherein each of the at least two main dampers is connected to the corresponding damper bracket.

11. The drum type washing machine of claim 2, the attenuating part comprising at least three dampers provided to support the weight of the drum and attenuate vertical vibration of the drum.

12. The drum type washing machine of claim 11, the attenuating part comprising:

at least two main dampers provided to support the weight of the drum; and

at least one rear damper provided to prevent the drum from inclining to one side.

13. The drum type washing machine of claim 12, wherein the rear damper is configured to prevent the drum from inclining to a front or rear side of the drum.

14. The drum type washing machine of claim 12, the at least one damper bracket comprising a rear damper bracket configured to extend from the bearing housing to a center of a lower outer circumference of the tub to be joined to the at least one rear damper.

15. The drum type washing machine of claim 14, wherein each of the at least two main dampers is connected to the corresponding main damper bracket and wherein the rear damper is hinged to the rear damper bracket.

16. The drum type washing machine of claim 12, the at least two main dampers, each comprising:

a cylinder;

a piston provided to reciprocate within the cylinder according to a motion of the drum to attenuate the vibration of the drum; and

a spring configured to support the piston and have an elastic force when the piston enters the cylinder.

17. The drum type washing machine of claim 12, the rear damper comprising:

a cylinder;

a piston provided to reciprocate within the cylinder according to a motion of the drum to attenuate the vibration of the drum; and

a spring configured to support the piston and have an elastic force when the piston is pulled out of the cylinder.

18. The drum type washing machine of claim 11, further comprising a sub-damper provided to attenuate horizontal vibration of the drum.

19. A drum type washing machine comprising:

a cabinet forming an exterior of the drum type washing machine;

a tub fixed within the cabinet, the tub having a laundry loading entrance at an outer circumference of the tub;

14

a drum rotatably provided within the tub, the drum having an opening on a lateral circumferential side of the drum to communicate with the laundry loading entrance of the tub;

a motor assembly provided next to one side of the drum to rotate the drum, the motor assembly including a rotational shaft connected to the drum and a bearing housing to rotatably support the rotational shaft; and

a suspension assembly provided to support a weight of the drum and attenuate vibration of the drum, wherein the suspension assembly includes at least one damper bracket which is configured to be bent toward a front side of the tub from the bearing housing and a damper which is connected to the at least one damper bracket.

20. A drum type washing machine comprising:

a cabinet forming an exterior of the drum type washing machine;

a tub fixed within the cabinet, the tub having a laundry loading entrance at an outer circumference of the tub;

a drum rotatably provided within the tub, the drum having an opening on a lateral circumferential side of the drum to communicate with the laundry loading entrance of the tub;

a motor assembly provided next to one side of the drum to rotate the drum, the motor assembly including a rotational shaft connected to the drum and a bearing housing to rotatably support the rotational shaft; and

a suspension assembly provided to support a weight of the drum and attenuate vibration of the drum, the suspension assembly comprising at least two damper brackets and at least two dampers, wherein each of the at least two damper brackets extends from the bearing housing to an outside of each lower side of an outer circumference of the tub, and is bent toward a front side of the drum, and extends to a prescribed length, and the two dampers are connected to the two damper brackets, respectively.

21. *The drum type washing machine of claim 1, wherein the suspension assembly comprises a first bracket, the first bracket comprising a first bracket portion attached to the plate and extending in a radial direction of the rotational shaft, and a second bracket portion connected to the first bracket portion and extending in a rotational axis direction of the drum.*

22. *The drum type washing machine of claim 21, wherein the first bracket portion comprises an end bent in the rotational axis direction and connected to the second bracket portion.*

23. *The drum type washing machine of claim 21, wherein the suspension assembly comprises a main damper connected to an end of the second bracket portion that supports the weight of the drum and attenuate a vertical vibration of the drum.*

24. *The drum type washing machine of claim 23, wherein the suspension assembly further comprises a sub-damper that attenuates a horizontal vibration of the drum.*

25. *The drum type washing machine of claim 24, wherein the sub-damper is connected to the second bracket portion.*

26. *The drum type washing machine of claim 24, wherein the sub-damper is hinged at both ends thereof.*

27. *The drum type washing machine of claim 23, wherein the suspension assembly further comprises an elastic member that connects the bearing housing to a top side of the cabinet.*

28. *The drum type washing machine of claim 23, wherein the main damper comprises:*
a cylinder;

15

a piston that reciprocates within the cylinder according to a motion of the drum to attenuate the vibration of the drum; and

a spring configured to elastically support the piston.

29. The drum type washing machine of claim 28, wherein a frictional member is provided at an outer circumference of the piston that attenuates the vibration by making a frictional contact with an inner circumference of the cylinder according to a motion of the piston.

30. The drum type washing machine of claim 21, further comprising a second damper bracket, the second damper bracket comprising a third bracket portion attached to the bearing housing and extending in a radial direction of the shaft, and a fourth bracket portion connected to the third bracket portion and extending in the rotational axis direction of the drum.

31. The drum type washing machine of claim 21, wherein the suspension assembly comprises at least three dampers that support the weight of the drum and attenuate a vertical vibration of the drum.

32. The drum type washing machine of claim 31, wherein the at least three dampers comprises:

at least two main dampers that support the weight of the drum; and

at least one rear damper that prevents the drum from inclining to one side.

33. The drum type washing machine of claim 32, wherein the suspension assembly further comprises a rear damper bracket configured to extend from the bearing housing to a center of a lower outer circumference of the tub to be joined to the at least one rear damper.

34. The drum type washing machine of claim 33, wherein each of the at least two main dampers is connected to the corresponding main damper bracket and wherein the rear damper is hinged to the rear damper bracket.

16

35. The drum type washing machine of claim 32, wherein the at least two main dampers each comprise:

a cylinder;
a piston that reciprocates within the cylinder according to a motion of the drum to attenuate the vibration of the drum; and

a spring configured to support the piston and have an elastic force when the piston enters the cylinder.

36. The drum type washing machine of claim 32, wherein the rear damper comprises:

a cylinder;
a piston that reciprocates within the cylinder according to a motion of the drum to attenuate the vibration of the drum; and

a spring configured to support the piston and have an elastic force when the piston is pulled out of the cylinder.

37. The drum type washing machine of claim 31, wherein the rear damper is configured to prevent the drum from inclining toward a front side or a rear side thereof.

38. The drum type washing machine of claim 31, wherein the suspension assembly further comprises a sub-damper that attenuates a horizontal vibration of the drum.

39. The drum type washing machine of claim 1, wherein the suspension assembly includes at least one bracket bent toward a front side of the tub from the plate and at least one damper connected to the at least one bracket, and wherein the at least one bracket extends in a rotational axis direction of the tub.

40. The drum type washing machine of claim 1, wherein the suspension assembly comprises at least two brackets and at least two dampers, wherein each of the at least two brackets extends from the plate to an outside of each lower side of an outer circumference of the tub, is bent toward a front side of the drum, and extends a predetermined length, and wherein the two dampers are connected to the two brackets, respectively.

* * * * *