

(19)  
(12)

(KR)  
(A)

(51) 。 Int. Cl. 7  
D04B 27/24

(11)  
(43)

2002 - 0007162  
2002 01 26

(21) 10 - 2001 - 0040205  
(22) 2001 07 06

(30) 10035160.3 2000 07 19 (DE)

(71) ;  
, 63179 , 25

(72) , - 63150 ,가 48

(74)

:

(54)

가 (10) 1 가 가 (1)  
(10) (4, 6)가 (1)

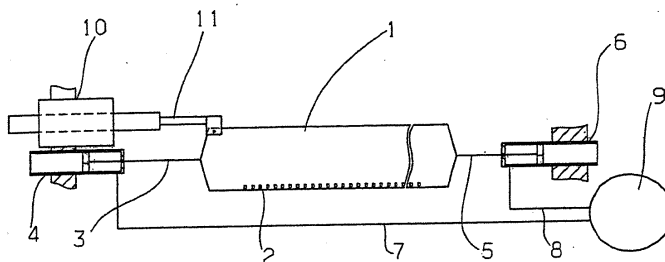

, 가 , , , ,

1

2 1 2

3 1 3

4 1 4

5

< >

1, 301: 2, 302:

3, 5, 103, 203: 4, 6:

7, 8: 9:

10, 210: 11:

20: 21:

22: 23:

24: 25:

26: 212:

314: 315, 316:

317: 318:

가 가 가

DT 26 10 888 A1 ( 7)

가

, DT 26 10 888 A1 ( 6)

가  
가

가

1

가

가

가

가

가

가

가

가

가

가

가

가

0.01 mm

가

0.005 mm



, 가 , 가 .

(57)

1.

가 1 가 가 ,  
(4, 6)가 .

2.

1 , .

3.

1 , (1) .

4.

1 , (4) (110; 210; 310) (103; 203  
; 317) (1) .

5.

4 , (317) (310) (318)

6.

4 , (203) (210) (212)

7.

1 , (4, 6)

8.

7 , 가 .

9.

7 , 가 , (9)

10.

7 , (20) , (21)

11.

7 , (21) (20) (26) 0.01 mm

12.

7 , 2 mm (22)가

13.

7 , (7, 8) 25 %

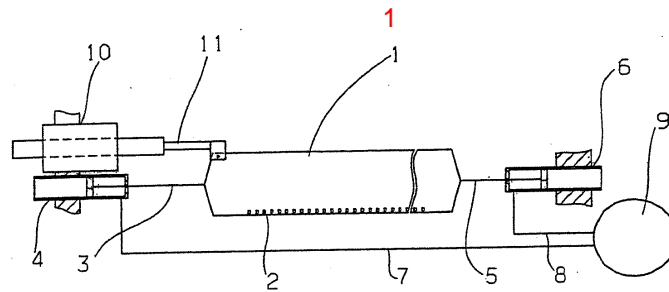

2

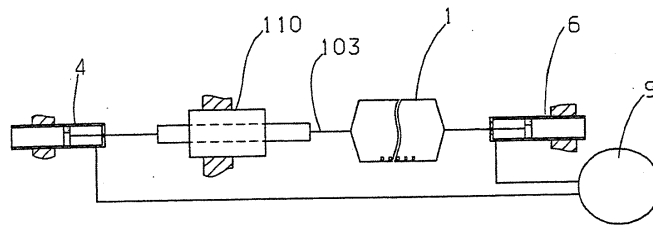

3

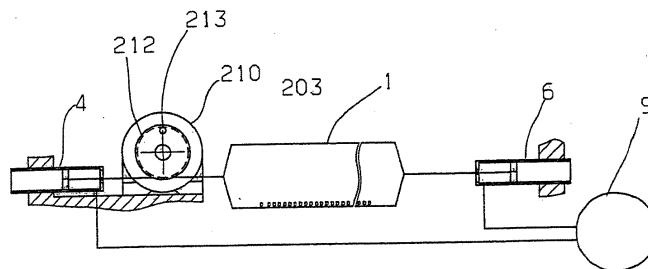

4

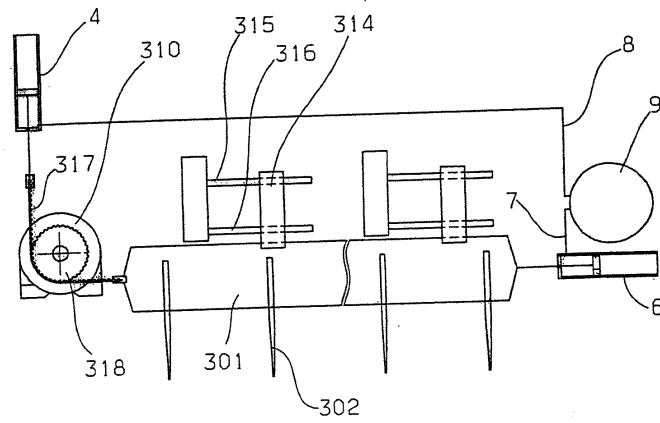

5

