



- (51) **International Patent Classification:**  
*H01M 10/02* (2006.01)
- (21) **International Application Number:**  
PCT/US2015/022226
- (22) **International Filing Date:**  
24 March 2015 (24.03.2015)
- (25) **Filing Language:** English
- (26) **Publication Language:** English
- (30) **Priority Data:**  
61/981,134 17 April 2014 (17.04.2014) US
- (72) **Inventor; and**
- (71) **Applicant :** GEORGE, Kreigler, III [US/US]; 8837 Villa La Jolla Drive, #13593, La Jolla, CA 92039 (US).
- (74) **Agent:** VIEIRA, Erik; 8837 Villa La Jolla Drive, #13593, La Jolla, CA 92039 (US).
- (81) **Designated States** (*unless otherwise indicated, for every kind of national protection available*): AE, AG, AL, AM, AO, AT, AU, AZ, BA, BB, BG, BH, BN, BR, BW, BY, BZ, CA, CH, CL, CN, CO, CR, CU, CZ, DE, DK, DM, DO, DZ, EC, EE, EG, ES, FI, GB, GD, GE, GH, GM, GT,

HN, HR, HU, ID, IL, IN, IR, IS, JP, KE, KG, KN, KP, KR, KZ, LA, LC, LK, LR, LS, LU, LY, MA, MD, ME, MG, MK, MN, MW, MX, MY, MZ, NA, NG, NI, NO, NZ, OM, PA, PE, PG, PH, PL, PT, QA, RO, RS, RU, RW, SA, SC, SD, SE, SG, SK, SL, SM, ST, SV, SY, TH, TJ, TM, TN, TR, TT, TZ, UA, UG, US, UZ, VC, VN, ZA, ZM, ZW.

- (84) **Designated States** (*unless otherwise indicated, for every kind of regional protection available*): ARIPO (BW, GH, GM, KE, LR, LS, MW, MZ, NA, RW, SD, SL, ST, SZ, TZ, UG, ZM, ZW), Eurasian (AM, AZ, BY, KG, KZ, RU, TJ, TM), European (AL, AT, BE, BG, CH, CY, CZ, DE, DK, EE, ES, FI, FR, GB, GR, HR, HU, IE, IS, IT, LT, LU, LV, MC, MK, MT, NL, NO, PL, PT, RO, RS, SE, SI, SK, SM, TR), OAPI (BF, BJ, CF, CG, CI, CM, GA, GN, GQ, GW, KM, ML, MR, NE, SN, TD, TG).

**Declarations under Rule 4.17:**

- *of inventorship (Rule 4.17(iv))*

**Published:**

- *without international search report and to be republished upon receipt of that report (Rule 48.2(g))*



(54) **Title:** AN ENERGY STORAGE APPARATUS

(57) **Abstract:** An energy storage apparatus having at least one flat, rectangular energy cell, with a positive and negative electrode and separator, all of which are adapted to be housed in at least one flat, rectangular pouch cell, impregnated with electrolyte, disposed within a rectangular rack mount housing, having positive and negative wire harnesses operatively coupled to the energy cell for access to stored energy.

**PATENT COOPERATION TREATY  
PATENT APPLICATION  
IN THE NAME OF**

**George Kreigler III**

**FOR**

**AN ENERGY STORAGE APPARATUS**

**DOCKET NO. GK-001-PCT**

*Prepared by*

**Erik M. Vieira**

**USPTO Reg. No. 53,723  
8837 Villa La Jolla Drive #13593  
La Jolla, CA 92039  
Phone (619) 743.1551**

## AN ENERGY STORAGE APPARATUS

### CROSS REFERENCE TO RELATED APPLICATIONS

This Patent Cooperation Treaty Patent Application claims the benefit of priority to earlier filed United States Provisional Patent Application entitled, “AN ENERGY STORAGE APPARATUS”, to Kreigler, filed April 17, 2014, and having serial number 61/981,134.

### BACKGROUND

#### *Related Art*

[001] Modern state of the art energy storage technologies utilize a large volume of metal to house energy storage devices, such as batteries and supercapacitors. Furthermore, a significant amount of space is wasted in modern cylindrical energy storage apparatuses, particularly in apparatuses adapted to deliver large power loads, such as in automotive applications. If space were not wasted, such volumes could be used to store energy. The process to make cells is expensive and requires a great deal of capital equipment to manufacture the product. There are also a great many steps necessary to complete in order to make even one cell. Moreover, entire process is long and expensive.

[002] Batteries and supercapacitors are most frequently wound and housed in mechanical cylinders. To achieve higher energy storage levels, these mechanical cylinders are frequently concatenated and connected via large bus bars. These cells are then welded together with the large bus bars and then encased in heavy metal containers. Space in between successive cylinders is unutilized for energy storage, or any useful means. Circular cells by their design leave a large amount of empty space, which is wasted in each module.

[003] The present teachings disclose an apparatus, method, and article of manufacture for eliminating substantial quantities of metal and wasted space used to house modern energy storage devices. Furthermore, the present teachings show how the previously wasted volume may be utilized to house additional energy storage medium. The present disclosure further teaches methods for exchanging weight contributions from metal for weight

contributions from additional energy storage medium, improving overall energy density and lowering manufacturing costs.

## BRIEF DESCRIPTION OF THE DRAWINGS

[004] Embodiments of the present disclosure will be more readily understood by reference to the following figures, in which like reference numbers and designations indicate like elements.

5 [005] FIGURE 1a illustrates an exploded view of a pouch cell, according to one embodiment of the present teachings.

[006] FIGURE 1b illustrates a perspective view of a pouch cell, according to one embodiment of the present teachings.

10 [007] FIGURE 1c illustrates an exploded view of a pouch cell, according to one embodiment of the present teachings.

[008] FIGURE 2a illustrates an exploded view of an energy storage apparatus, according to one embodiment of the present teachings.

[009] FIGURE 2b illustrates a perspective view of an energy storage apparatus, according to one embodiment of the present teachings.

15 [010] FIGURE 3 illustrates a power management system, according to one embodiment of the present teachings.

## DETAILED DESCRIPTION

### *Overview*

[011] The present teachings disclose a high power and high energy solution that is readily scalable and fits in multiple platforms at a very low cost of manufacturing. The present  
5 teachings disclose a method, apparatus, system and article of manufacture for an energy storage device, which can yield a 300% improvement to energy density over that which is available in modern energy storage devices. Furthermore, the present disclosure illustrates ecologically friendly methods for reducing waste by substantially reducing volumes of metal necessary to house an energy storage apparatus. The present teachings also disclose an energy storage  
10 apparatus, which has fewer points of failure than currently available solutions. And, because of significant weight reduction for comparable energy densities using the present teachings, weight sensitive applications such as the automotive industry will greatly benefit. A myriad of other power and energy applications will be apparent to those skilled in the art employing the present teachings, such as heavy transportation, hybrid vehicles, power grid, board net stabilization,  
15 windmills, and dirty energy filtration. The present teachings also reduce output impedance of an energy storage device, compared with current state of the art solutions. For example, one modern supercapacitor is a 48 volt module, at 166 farads, with a resistance of 6 milliohms. In one example of the present teachings a newly designed 48 volt module equivalent product will have an increased capacitance of 334 farads and an improved resistance at 2.4 milliohms, to as  
20 high as 1992 farads at an improved resistance of 0.4 milliohms, depending on size and configuration, with the overall product weight decreased by approximately 40%. Due to elimination of significant amounts of metal, manufacturing and materials costs are reduced by approximately 45%. Employing techniques disclosed in the present teachings can yield up to 16 times more energy at a given power rating than currently available, with nearly half the weight  
25 and half the space required.

[012] Referring now to FIGURE 1a, illustrating an exploded view, in one embodiment, a pouch cell apparatus 100 is illustrated, comprising an upper non conducting flat rectangular pouch layer 106 and a lower non conducting flat rectangular pouch layer 104, an energy cell 102 having a positive tab 108 and a negative tab 110, and an electrolyte (not shown).

[013] The pouch cell 100 has four edges, wherein each edge extends slightly beyond an edge length of the energy cell 102. Two of the pouch cell edges are adapted to fit the positive tab 108 and the negative tab 110 there through, such that the tabs extend outwardly of the pouch cell edges. Methods of manufacturing the pouch cell include a step of impregnation of the pouch cell with electrolyte, either before or during the step of ultrasonically welding the pouch cell edges together, in a manner that seals the electrolyte entirely within the pouch cell. The pouch cell edges adapted to fit the positive and negative tabs there through are also sealed such that electrolyte impregnating an internal portion of the pouch cell do not leak therefrom.

[014] The energy cell 102 has four edges, including a flat rectangular positive electrode layer and a flat rectangular negative electrode layer. The positive tab 108 protrudes laterally outward from the flat rectangular positive electrode layer. The negative tab 110 protrudes laterally outward from the flat rectangular negative electrode layer. A flat rectangular separator is disposed there between the positive electrode layer and the negative electrode layer to physically separate the two electrodes to prevent an electrical shorting between layers. The separator may be composed of paper, non woven porous polymeric films, polyacrylonitrile, kapton, woven glass fibers or porous woven ceramic fibers. The non conducting pouch cell 100, adapted to house and seal the energy cell 102 is ultrasonically welded about the energy cell to seal. It will be appreciated that both electrode layers may be composed of carbon electrodes or derivatives, metal oxide or conducting polymer electrodes. In some embodiments, the energy cell 102 may comprise a supercapacitor configured as a double layer capacitor, pseudocapacitor and/or a hybrid capacitor. In other embodiments, the energy cell 102 may comprise a battery apparatus, such as for example a lithium ion battery. FIGURE 1b illustrates a perspective view of the embodiment of FIGURE 1a, after the edges have been ultrasonically welded and sealed.

[015] Referring now to Figure 1c, an exploded view of a pouch cell 100 is illustrated. Figure 1c is similar to the above referenced Figure 1a and Figure 1b, but further illustrates the energy cell 102 enclosed by an upper housing 107 and a lower housing 105. When assembled, the upper housing 107 and lower housing 105 will be fitted together to provide an enclosure for the energy cell 102. In one embodiment, the upper housing 107 and the lower housing 105 are made of Acetonitrile resistant materials, such as for example polypropylene. As shown in Figure 1c, the upper housing 107 comprises a plurality of perforations 111 which

function as an aperture to allow electrolyte to flow freely in and out of the enclosure such that the electrolyte may come into contact with the energy cell 102. Similarly, the lower housing 105 comprises a plurality of perforations 109 which function as an aperture to allow electrolyte to flow freely in and out of the enclosure such that the electrolyte may come into contact with the energy cell 102. The upper housing 107 and the lower housing 105 encases a stacked electrode package and locks the electrodes in place so they cannot move or separate. It will be appreciated that one of the issues with prismatic cells is that the electrode may produce gaps between the anode and cathode over time, which may lead to performance problems. The upper housing 107 and the lower housing 105 functions to enclose the electrodes, ensuring that there is no movement or separation between the layers of anode, separator and cathode. Once the housing enclosure is fitted together around the electrodes, the assembly is placed inside the pouch cell, electrolyte is added and the pouch is vacuum sealed.

FIGURE 2a illustrates an exploded view of an energy storage apparatus 200 and FIGURE 2b illustrates a perspective view of the energy storage apparatus 200 completely assembled. FIGURE 2a illustrates an energy storage apparatus 200 comprising a plurality of pouch cells 210 vertically arranged and aligned as shown, having a positive wire harness 212 and a negative wire harness 214. In this embodiment, a plurality of positive tabs are aligned vertically from each respective one of the plurality of pouch cells 210 on a first side, and a plurality of negative tabs are aligned vertically from each respective one of the plurality of pouch cells on a second side. It will be appreciated that in one embodiment, each of the plurality of positive tabs are ultrasonically welded together and thereby coupled and that each of the plurality of negative tabs are ultrasonically welded together and thereby coupled. A positive wire harness 212 is subsequently affixed to the coupled positive tabs and a negative wire harness 214 is affixed to the coupled negative tabs. The positive and negative wire harnesses 212 214 are adapted to electrically couple the positive and negative tabs to a positive and negative terminal respectively. A rectangular rack mount housing is adapted to enclose the plurality of pouch cells 210, and the wire harnesses 212 214. The rectangular rack mount housing comprises a lower housing portion 202, a top housing portion 206, a rear housing portion 204 and a front housing portion 208. FIGURE 2b illustrates a perspective view of the fully assembled energy storage apparatus 200. The positive and negative terminals are adapted to extend outwardly from the

rectangular rack mount housing. The positive and negative terminals are thus adapted to facilitate electrical charging and discharging of the pouch cells.

[016] Modern energy storage devices typically compress multiple layers of electrode and wind the layers in a cylinder housed with metal. To achieve higher energy and/or power values, such as for example in heavy automotive applications, multiple cells are concatenated into a box and connected via bus bars. Nestling metal cylinders into a box yields unused space in the areas between cylinders. The present teachings completely avoid such wasted space by avoiding modern techniques of using cylinders to house energy storage devices, thereby maximizing valuable volumes of space. Moreover, such previously wasted space is now available for additional energy storage elements employing techniques of the present disclosure. Also, because modern heavy automotive applications require multiple cells concatenated with bus bars, there are more points of potential failure in such devices than exist in the presently disclosed device.

[017] As illustrated in FIGURE 2a, a plurality of pouch cells may be contained within a single rectangular rack mount housing. It will be appreciated that employing techniques of the present teachings, a scalable energy storage apparatus is further disclosed, which is readily customizable for various energy and power requirements. In one example, if each pouch cell comprises a supercapacitor energy storage cell, having a predetermined voltage, such pouch cells may be layered to additively create a specified energy requirement. For example, in 12 volt applications, a plurality of pouch cells may be layered to create the required 12 volts, such as each pouch cell having 3 volts capacity. It will be appreciated that 2.7 volt pouch cells may also be used in the present teachings. Literally any voltage or farad value may be used as the predetermined voltage or capacitance, without departing from the spirit and scope of the present teachings.

[018] In one embodiment, at least one supercapacitor pouch cell layer and at least one battery pouch cell layer are housed within a rectangular rack mount housing having one negative external terminal and one positive external terminal. Charging and discharging power management is accomplished via a balancing circuit internally disposed with respect to the rectangular rack mount housing. This novel embodiment is a component level combination of an energy device and a power device. Internally, a first wire harness may be used to connect each

respective power device to the balancing circuit for control of charging and discharging. Similarly, a second wire harness may be used to connect each respective energy device to the balancing circuit to control charging and discharging. Such a combined energy and power device is useful for a myriad of applications. In one example, in an automotive regenerative braking application, current state of the art methods of employing a battery to recover energy when braking are limited in that a battery is only able to recharge at a relatively low rate when compared with a supercapacitor. Therefore, it would be advantageous in such applications to have a supercapacitor available for regenerative braking rapid charging, as a super capacitor can intake large amounts of energy very quickly. The balancing circuit can be configured to flow as much regenerative braking charge to the battery pouch cells as possible without damaging the battery pouches, and flow the remaining charge to super capacitor pouch cells, such that no energy is wasted in the regenerative braking process.

[019] Current state of the art battery and supercapacitor technology uses a cylindrical metal housing to enclose what the present teachings house in a pouch cell. As previously described in disclosed embodiments, no metal is used to encase individual pouch cells. Therefore, significant manufacturing cost savings are immediately realized due to the elimination of most of the metal associated with housing an energy storage device. Furthermore, the present teachings replace the previously wasted volume of metal with additional volumes of electrode, resulting in higher energy per unit volume or mass. For example, modern super capacitors may be rated at 3 or 4 Watt-hours per kilogram, whereas the disclosed energy storage apparatus can be rated at 12 Watt-hours per kilogram.

[020] It will be appreciated that the specific rectangular geometry of the disclosed energy storage apparatus is variable and may be configured depending upon the specific application requirements.

[021] In one embodiment, the energy storage apparatus is made up of 16 to 64 square or rectangular layers of negative and positive electrode. A separator paper separates each electrode layer. On each electrode is a tab in which current travels. The negative and positive electrode and tabs are interleaved so that the negative tabs are on one side and the positive tabs are on the opposite side. Once the electrodes are interleaved the tabs are ultra-sonically welded

together. The positive tabs are connected together and the negative tabs are ultra-sonically welded together. This creates one negative lead and a positive lead. An interlocking comb then encompasses the assembly to hold the structure in place. This assembly is then encased in an aluminum bag. The unit is impregnated with electrolyte and is then vacuum-sealed. The two  
5 leads are ultra-sonically welded to the bag and exposed. This creates a 2.7 volt or 3.0 volt pouch cell. The size of the layer can be cut into various squares or shapes depending on the energy requirements. For example, four 3 volt pouches may be combined and these tabs are ultra-sonically connected in series to create a 12 volt energy storage apparatus. A wire harness is connected to each tab. The entire assembly is then encased in an aluminum or stainless steel  
10 structure. Each 12 volt energy storage apparatus can then be used individually or connected in a rack to increase voltage. Each blade can also increase in energy by increasing the number of layers and or the size of the configuration.

[022] This design on average can increase the energy density of a supercapacitor by 3 times by increasing the carbon surface area in squares or rectangles verses the present state of  
15 the art circular designs. This also results in a 2.5 times improvement in equivalent series resistance.

[023] Figure 3 illustrates a power management system 300, according to one embodiment of the present teachings. The power management system 300 may be adapted for use in automotive applications. In one embodiment, each energy storage apparatus (Energy  
20 Blade™) may be 12 volts, 15 volts, 24 volts, or 48 volts depending on the number of pouch cells. In one illustrative exemplary embodiment, a first module 302 comprises an internal balance control. For example, if the first module 302 is 12 volts, comprising four 3 volt pouches, the internal balance control functions to balance all internal 3 volt pouches such that none of the pouches exceeds 3 volts. In one embodiment, this may be a resistor circuit or optionally a more  
25 complex microprocessor controller circuit that may switch off charging of any individual pouch before it exceeds 3 volts. In one exemplary embodiment, a battery and/or supercapacitor energy storage apparatus is connected to an external power source, such as for example an alternator or other plug-in source. It will be appreciated that in one variation, a supercapacitor energy storage apparatus as described herein may optionally be configured to be charged from a battery energy  
30 storage apparatus.

[024] The foregoing description illustrates exemplary implementations, and novel features, of aspects of an energy storage apparatus, method and article of manufacture. Alternative implementations are suggested, but it is impractical to list all alternative implementations of the present teachings. Therefore, the scope of the presented disclosure should be determined only by reference to the appended claims, and should not be limited by features illustrated in the foregoing description except insofar as such limitation is recited in an appended claim.

[025] While the above description has pointed out novel features of the present disclosure as applied to various embodiments, the skilled person will understand that various omissions, substitutions, permutations, and changes in the form and details of the present teachings illustrated may be made without departing from the scope of the present teachings.

[026] Each practical and novel combination of the elements and alternatives described hereinabove, and each practical combination of equivalents to such elements, is contemplated as an embodiment of the present teachings. Because many more element combinations are contemplated as embodiments of the present teachings than can reasonably be explicitly enumerated herein, the scope of the present teachings is properly defined by the appended claims rather than by the foregoing description. All variations coming within the meaning and range of equivalency of the various claim elements are embraced within the scope of the corresponding claim. Each claim set forth below is intended to encompass any apparatus or method that differs only insubstantially from the literal language of such claim, as long as such apparatus or method is not, in fact, an embodiment of the prior art. To this end, each described element in each claim should be construed as broadly as possible, and moreover should be understood to encompass any equivalent to such element insofar as possible without also encompassing the prior art. Furthermore, to the extent that the term "includes" is used in either the detailed description or the claims, such term is intended to be inclusive in a manner similar to the term "comprising".

## CLAIMS

What is claimed is:

1.) An energy storage apparatus, comprising:

an energy cell, having four edges, comprising:

5 a flat rectangular positive electrode layer, having a positive tab, protruding outwardly therefrom;

a flat rectangular negative electrode layer, having a negative tab, protruding outwardly therefrom;

10 a flat rectangular separator, wherein the flat rectangular separator is disposed between the flat rectangular positive electrode layer and the flat rectangular negative electrode layer;

a pouch cell, having four edges, adapted to house the energy cell, comprising:

15 an upper non-conducting flat rectangular pouch layer, disposed above the energy cell, wherein the upper non-conducting flat rectangular pouch layer has edges extending laterally beyond the four edges of the energy cell;

a lower non-conducting flat rectangular pouch layer, disposed below the energy cell, wherein the lower non-conducting flat rectangular pouch layer has edges extending laterally beyond the four edges of the energy cell,

20 wherein the upper non-conducting flat rectangular pouch layer edges are mechanically coupled to the lower non-conducting flat rectangular pouch layer, wherein the energy cell is adapted to fit entirely within the pouch cell, wherein the positive tab is adapted to extend outwardly of the pouch cell and the negative tab is adapted to extend outwardly of the pouch cell, wherein the pouch cell edges are adapted to be ultrasonically welded and sealed;

25 an electrolyte, adapted to impregnate an internal portion of the pouch cell;

a positive wire harness, adapted to electromechanically couple to the positive tab;

a negative wire harness, adapted to electromechanically couple the negative tab, and;

30 a rectangular rack mount housing, adapted to enclose the energy storage apparatus, wherein the rectangular rack mount housing comprises a positive terminal and a negative terminal operatively coupled to the positive wire harness and the negative wire harness respectively.

- 2.) The energy storage apparatus of Claim 1, further comprising a plurality of energy storage cells, wherein each respective one of the energy storage cells is adapted to be housed within a corresponding one of a plurality of pouch cells.
- 3.) The energy storage apparatus of Claim 2, wherein each respective positive tab of each  
5 flat rectangular positive electrode layer is adapted to be ultrasonically welded together.
- 4.) The energy storage apparatus of Claim 3, wherein each respective negative tab of each flat rectangular negative electrode layer is adapted to be ultrasonically welded together.
- 5.) The energy storage apparatus of Claim 4, wherein each respective one of the energy cells comprises a predetermined voltage.
- 10 6.) The energy storage apparatus of Claim 4, wherein each respective one of the energy cells comprises 2.7 volts.
- 7.) The energy storage apparatus of Claim 4, wherein each respective one of the energy cells comprises 3 volts.
- 8.) The energy storage apparatus of Claim 5 wherein each respective pouch cell comprises a  
15 predetermined farad value.
- 9.) The energy storage apparatus of Claim 8, wherein a total voltage output between the positive terminal and the negative terminal of the rectangular rack mount housing comprises a predetermined voltage.
- 10.) The energy storage apparatus of Claim 8, wherein a total voltage output between the  
20 positive terminal and the negative terminal of the rectangular rack mount housing comprises 12 volts.
- 11.) The energy storage apparatus of Claim 9, wherein the energy cell comprises a supercapacitor.
- 12.) The energy storage apparatus of Claim 11, wherein at least one of the plurality of energy  
25 cells comprises a battery.
- 13.) The energy storage apparatus of Claim 12, further comprising a balancing circuit operatively coupled to the negative and positive wire harnesses.

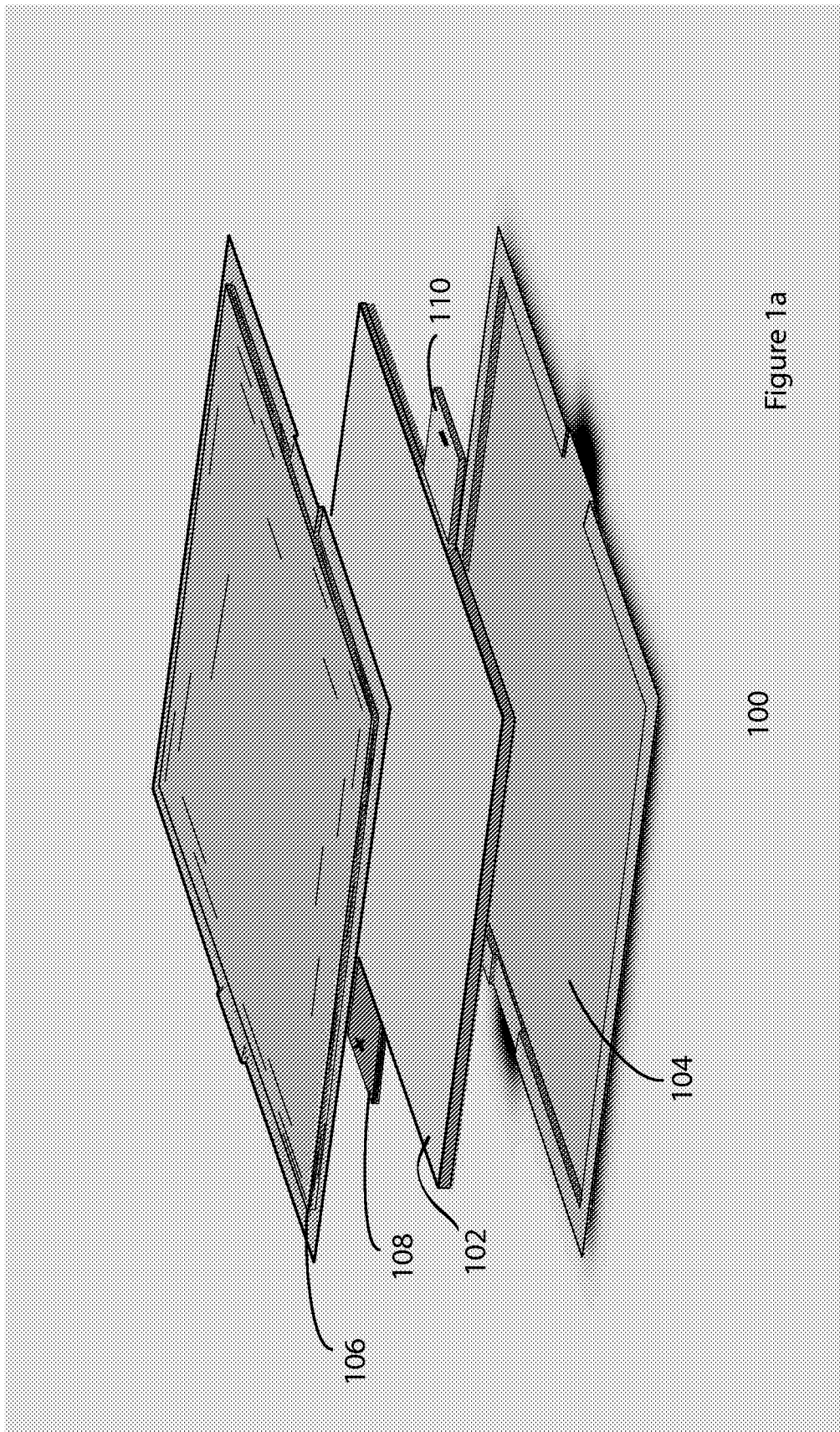

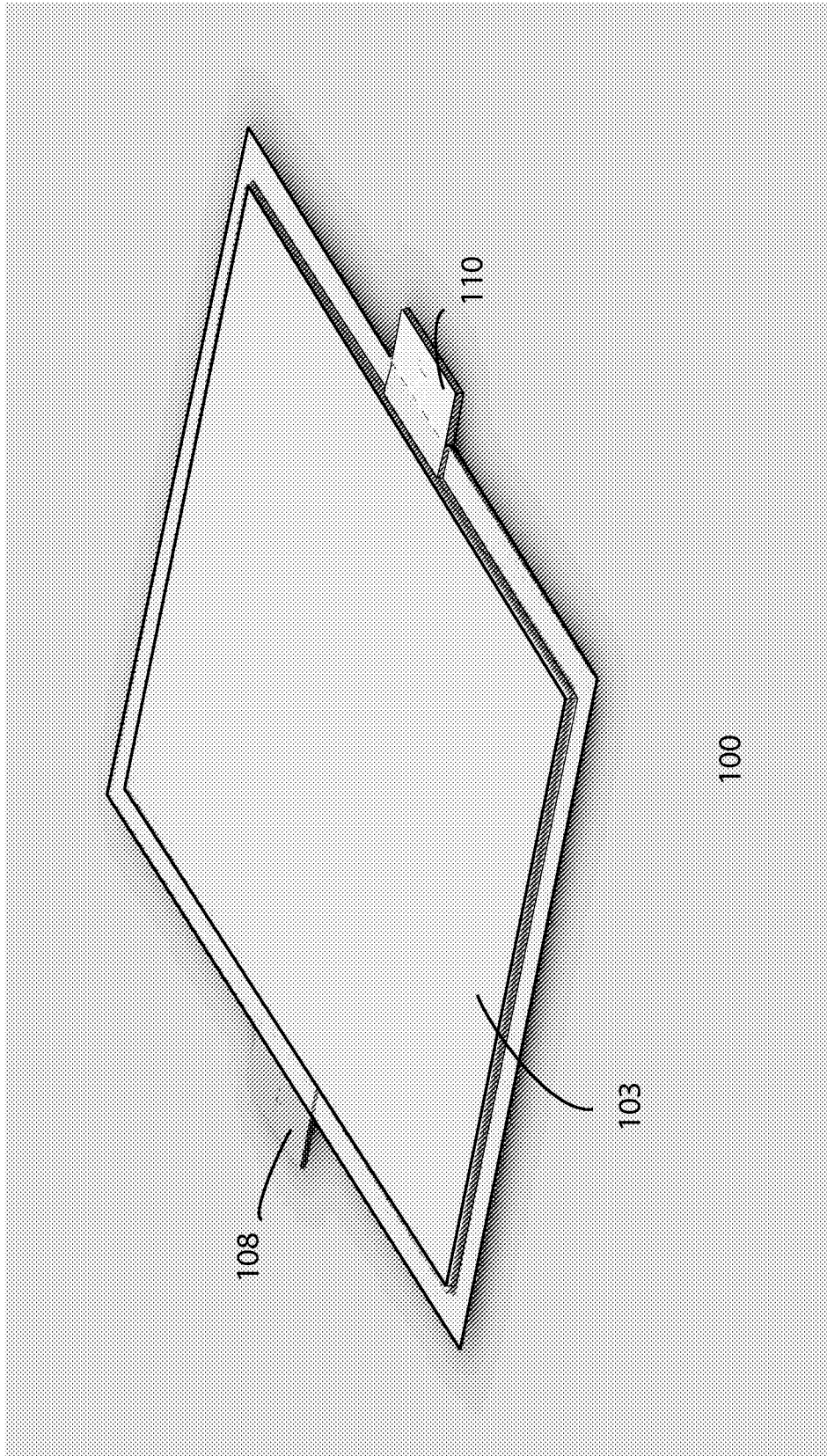

Figure 1b

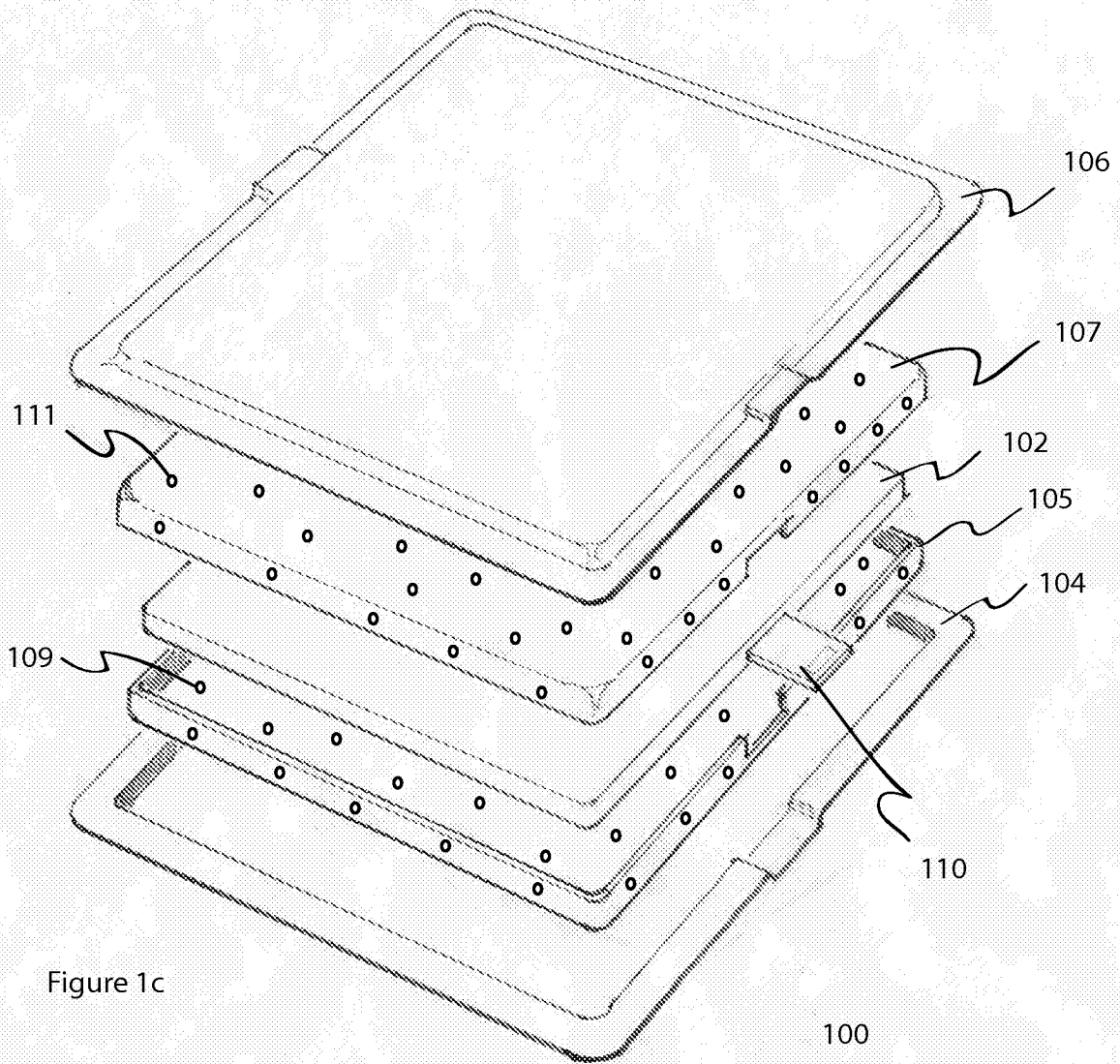

Figure 1c

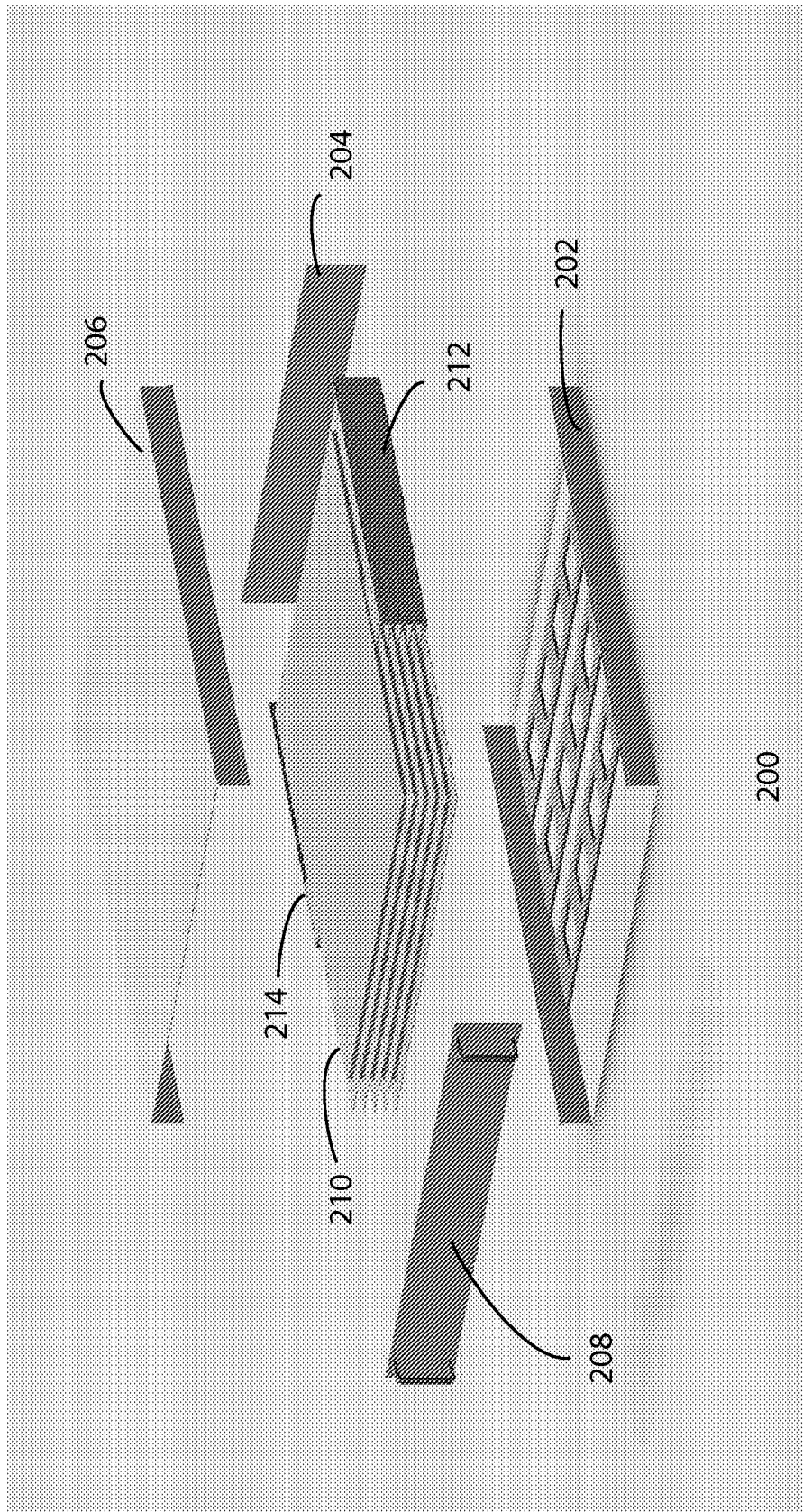

Figure 2a

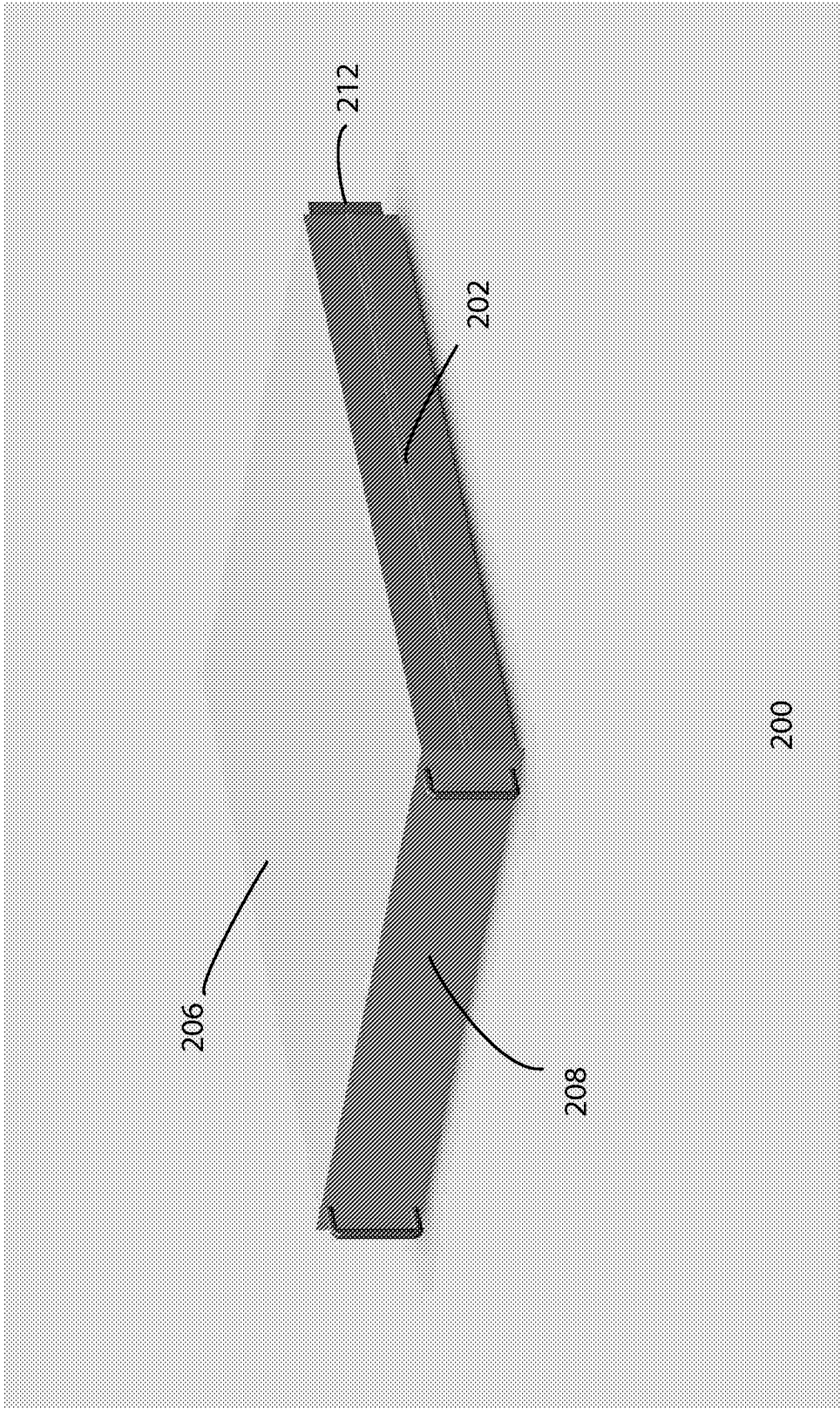

Figure 2b

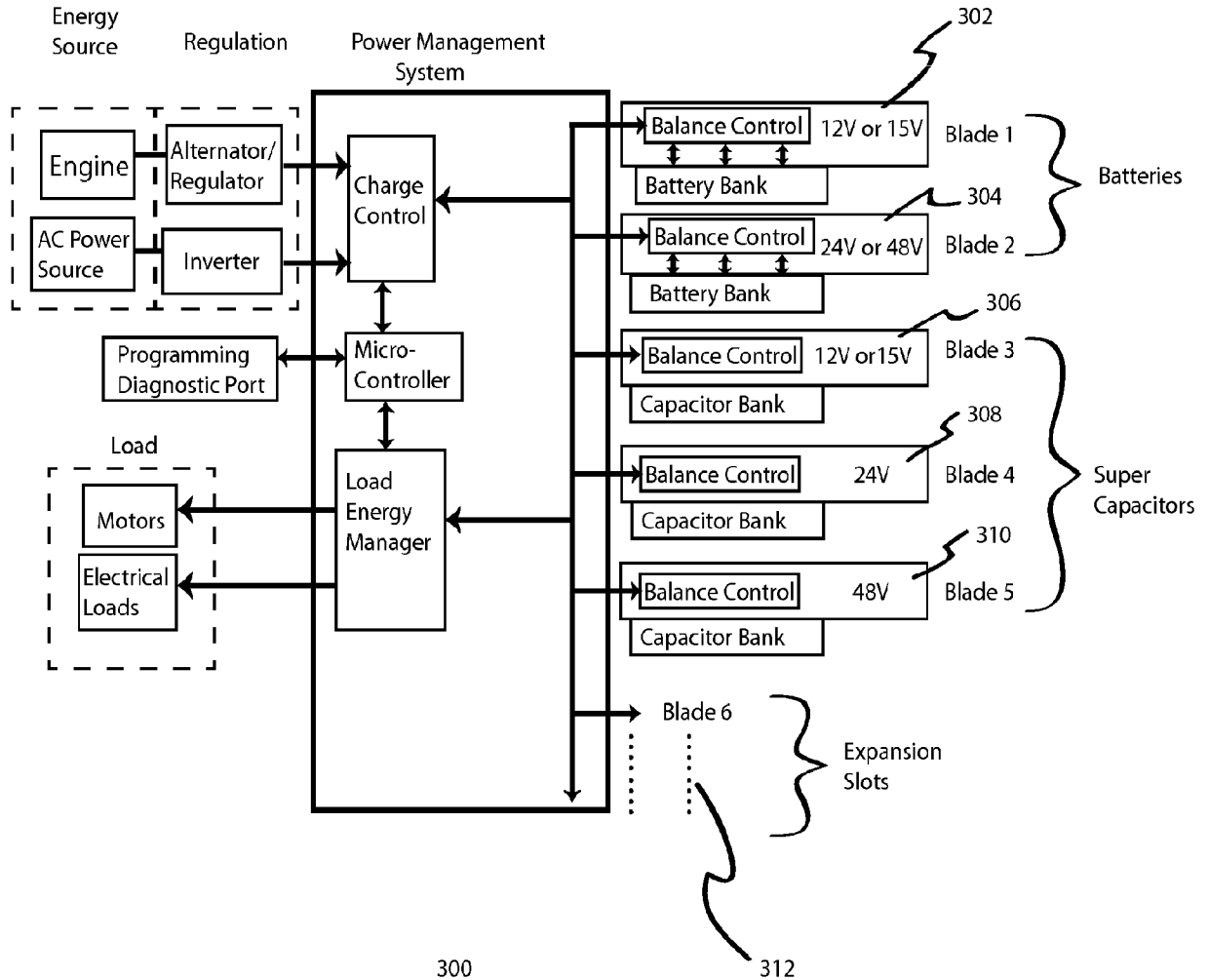

Figure 3