



INTERNATIONAL APPLICATION PUBLISHED UNDER THE PATENT COOPERATION TREATY (PCT)

(51) International Patent Classification ⁶ : H01M	A2	(11) International Publication Number: WO 00/02275 (43) International Publication Date: 13 January 2000 (13.01.00)
(21) International Application Number: PCT/GB99/02133 (22) International Filing Date: 1 July 1999 (01.07.99) (30) Priority Data: 9814123.7 1 July 1998 (01.07.98) GB (71) Applicant (for all designated States except US): BG PLC [GB/GB]; 100 Thames Valley Park Drive, Reading, Berkshire RG6 1PT (GB). (72) Inventors; and (75) Inventors/Applicants (for US only): MCLEAN, Gerard, Francis [CA/CA]; 4077 Ebony Terrace, Victoria, British Columbia V8N 3Z2 (CA). REID, Christopher, Edwin, John [CA/CA]; 2-1258 Balmoral Road, Victoria, British Columbia V8T 1B3 (CA). DJILALI, Ned [CA/CA]; 2110 Wenman Drive, Victoria, British Columbia V8N 2S2 (CA). CRANE, Patricia [CA/CA]; 7246 Skyline Crescent, Saanichton, British Columbia V8M 1M4 (CA). (74) Agent: MORGAN, David, J.; BG plc, Intellectual Property Dept., 100 Thames Valley Park Drive, Reading, Berkshire RG6 1PT (GB).		(81) Designated States: AU, CA, CN, IN, JP, KR, SG, US, European patent (AT, BE, CH, CY, DE, DK, ES, FI, FR, GB, GR, IE, IT, LU, MC, NL, PT, SE). Published <i>Without international search report and to be republished upon receipt of that report.</i>
(54) Title: ELECTROCHEMICAL FUEL CELL HAVING AN UNDULATE MEMBRANE ELECTRODE ASSEMBLY		
(57) Abstract <p>A PEM-type fuel cell is formed from layered undulate MEA structures and separator strata alternating with each other in the stack dimension so that each layered MEA structure is disposed between and attached to an associated pair of separator strata so as to form at least one discrete plenum on each side of each layered MEA structure through which plenum reactant gas may be circulated. Each layered MEA structure is formed from proton exchange membrane material sandwiched between a pair of spaced-apart current collectors with electro-catalyst particles between the membrane material and each current collector so that the membrane material and electro-catalyst particles fill the space between the current collectors, forming together with the current collectors a layered MEA structure. Each separator stratum is attached to and provides an electrically conductive path between the current collectors of the layered MEA structures on either side of the separator stratum.</p>		

FOR THE PURPOSES OF INFORMATION ONLY

Codes used to identify States party to the PCT on the front pages of pamphlets publishing international applications under the PCT.

AL	Albania	ES	Spain	LS	Lesotho	SI	Slovenia
AM	Armenia	FI	Finland	LT	Lithuania	SK	Slovakia
AT	Austria	FR	France	LU	Luxembourg	SN	Senegal
AU	Australia	GA	Gabon	LV	Latvia	SZ	Swaziland
AZ	Azerbaijan	GB	United Kingdom	MC	Monaco	TD	Chad
BA	Bosnia and Herzegovina	GE	Georgia	MD	Republic of Moldova	TG	Togo
BB	Barbados	GH	Ghana	MG	Madagascar	TJ	Tajikistan
BE	Belgium	GN	Guinea	MK	The former Yugoslav Republic of Macedonia	TM	Turkmenistan
BF	Burkina Faso	GR	Greece			TR	Turkey
BG	Bulgaria	HU	Hungary	ML	Mali	TT	Trinidad and Tobago
BJ	Benin	IE	Ireland	MN	Mongolia	UA	Ukraine
BR	Brazil	IL	Israel	MR	Mauritania	UG	Uganda
BY	Belarus	IS	Iceland	MW	Malawi	US	United States of America
CA	Canada	IT	Italy	MX	Mexico	UZ	Uzbekistan
CF	Central African Republic	JP	Japan	NE	Niger	VN	Viet Nam
CG	Congo	KE	Kenya	NL	Netherlands	YU	Yugoslavia
CH	Switzerland	KG	Kyrgyzstan	NO	Norway	ZW	Zimbabwe
CI	Côte d'Ivoire	KP	Democratic People's Republic of Korea	NZ	New Zealand		
CM	Cameroon			PL	Poland		
CN	China	KR	Republic of Korea	PT	Portugal		
CU	Cuba	KZ	Kazakstan	RO	Romania		
CZ	Czech Republic	LC	Saint Lucia	RU	Russian Federation		
DE	Germany	LI	Liechtenstein	SD	Sudan		
DK	Denmark	LK	Sri Lanka	SE	Sweden		
EE	Estonia	LR	Liberia	SG	Singapore		

**ELECTROCHEMICAL FUEL CELL HAVING
AN UNDULATE MEMBRANE ELECTRODE ASSEMBLY**

RELATED APPLICATION

This application includes subject-matter incorporated from applicant's British Patent Application Serial No. No. 9814123.7 filed on 1 July 1998.

FIELD OF THE INVENTION

The present invention relates to electrochemical cells and particularly to fuel cells incorporating a proton exchange membrane. More particularly, the present invention relates to the preferred internal structure of such fuel cells, including such cells having a non-planar membrane electrode assembly.

BACKGROUND

Electrochemical fuel cells convert fuel and oxidant to electricity and reaction product. In electrochemical fuel cells employing hydrogen as the fuel and oxygen as the oxidant, the reaction product is water. Conventional proton exchange membrane ("PEM") fuel cells generally employ a planar, layered structure known as a membrane electrode assembly ("MEA"), comprising a solid polymer electrolyte or ion exchange membrane, which is neither electrically conductive nor porous, disposed between an anode electrode layer and a cathode electrode layer. The electrode layers are typically comprised of porous, electrically conductive sheets with electro-

catalyst particles at each membrane-electrode interface to promote the desired electrochemical reaction.

In conventional fuel cells, the MEA is interposed between two rigid, planar, substantially fluid-impermeable, electrically conductive plates, commonly referred to as separator plates. The plate in contact with the anode electrode layer is referred to as the anode plate and the plate in contact with the cathode electrode layer is referred to as the cathode plate. The separator plates (1) serve as current collectors, (2) provide structural support for the MEA, and (3) typically provide reactant channels for directing the fuel and oxidant to the anode and cathode electrode layers, respectively, and for removing products, such as water, formed during operation of the fuel cell. Fuel channels and oxidant channels are typically formed in the separator plates; the plates are then normally referred to as fluid flow field plates. Herein, "fluid" shall include both gases and liquids; although the reactants are typically gaseous, the products may be liquids or liquid droplets as well as gases.

During operation of the fuel cell, hydrogen from a fuel gas stream moves from fuel channels through the porous anode electrode material and is oxidized at the anode electro-catalyst to yield electrons to the anode plate and hydrogen ions which migrate through the electrolyte membrane. At the same time, oxygen from an oxygen-containing gas stream moves from oxidant channels through the porous electrode material to combine with the hydrogen ions that have migrated through the electrolyte membrane and electrons from the cathode plate to form water. A useful current of electrons

travels from the anode plate through an external circuit to the cathode plate to provide electrons for the reaction occurring at the cathode electro-catalyst.

Multiple unitary fuel cells can be stacked together to form a conventional fuel cell stack to increase the overall power output. Stacking is typically accomplished by the use of electrically conductive bipolar plates which act both as the anode separator plate of one fuel cell and as the cathode separator plate of the next fuel cell in the stack. One side of the bipolar plate acts as an anode separator plate for one fuel cell, while the other side of the bipolar plate acts as a cathode separator plate for the next fuel cell in the stack. The bipolar plates combine the functions of anode and cathode plates referred to above and are provided with the fuel channels and oxidant channels.

Fluid reactant streams are typically supplied to channels in the flow field plates via external inlet manifolds connected to the sides of the stack or by internal inlet manifolds formed by aligning openings formed in the bipolar plates and each MEA. Similarly, fluid stream exhaust manifolds may be external or internal exhaust manifolds. Typically the stack also has coolant passageways extending through the bipolar plates and each MEA for circulating a coolant fluid to explicit cooling plates that are interspersed between fuel cell layers in the stack to absorb heat generated by the fuel cell reactions.

A typical conventional bipolar plate has a plurality of parallel open-faced oxidant channels on one side and a plurality of parallel open-faced fuel

channels on the other side. The oxidant channels extend between an oxidant inlet manifold opening and an oxidant outlet manifold opening in the bipolar plate and typically traverse the central area of one plate surface in a plurality of passes, that is, in a serpentine manner, between the inlet manifold opening and the outlet manifold opening. Similarly, the fuel channels extend between a fuel inlet manifold opening and a fuel outlet manifold opening in the bipolar plate and traverse the central area of the other plate surface in a similar plurality of passes between the fuel inlet manifold opening and the fuel outlet manifold opening.

Channel patterns other than serpentine may be used in conventional fuel cell plates, but serpentine channel patterns have generally been found to work the best.

In conventional fuel cell designs only a portion of the porous electrode structure is exposed directly to the flow of reactants in the flow channels. The remainder of the porous electrode structure is in contact with the material of the typically non-porous, but electrically conducting flow field plates. In practice, conventional fuel cell design has involved a trade-off between (1) increasing the electrode area directly exposed to reactant flow thus increasing the current and power which can be produced by a given area of electrode material and (2) increasing the electrode area in contact with the flow field plates thus reducing the contact resistance between the electrode material and the conducting flow field plate material and increasing physical support for the somewhat fragile MEA.

The MEA needs physical support in a conventional

fuel cell stack as it is exposed to the compression forces needed to prevent fluid leaks between adjacent fluid flow channels in the fuel cell stack as well as to reduce contact resistance at the interface between the separator plates and the MEA. In conventional fuel cell designs such leakage is undesirable, particularly if the channels are serpentine, as some of the fluid may move directly from the inlet manifold opening across the channels to the outlet manifold opening without passing through the passes of the channels and so missing most of the MEA. To prevent such fluid movement, separator plates with extremely flat surfaces are required in conventional fuel cell stacks, necessitating either the grinding of the surfaces of the separator plates or the molds used to form the separator plates to exacting specific tolerances.

The compression needed to prevent leakage and reduce contact resistance is conventionally obtained by clamping the fuel cell stack together. Clamping is undesirable as fuel cell layers must be strong to resist crushing and the clamping hardware is bulky and adds weight to the fuel cell stack. Significantly higher power density could be obtained if clamping forces could be reduced or eliminated.

Watkins, U.S. Patents Nos. 4,988,583 and 5,108,849, issued 29 January 1991 and 28 April 1992, respectively, describe fluid flow field plates in which continuous open-faced fluid flow channels formed in the surface of the plate traverse the central area of the plate surface in a plurality of passes, that is, in a serpentine manner, between an inlet manifold opening and an outlet manifold opening formed in the plate. These patents are

representative of typical conventional fuel cell prior art in which the inventive subject matter appears to be the details of flow channel design, but in which planar MEA construction is assumed to be necessary.

Wilkinson, U.S. Patent No. 5,252,410, Grehier et al., U.S. Patents No. 4,037,023, and Toritani Hajime (assigned to Hitachi Ltd.), Japanese published patent specification 6-3116369, published 20 May 1988, present designs which retain the essentially planar nature of the electrolyte layer, but which form flow channels directly into the porous carbon electrode layers of the MEA. The resulting design perpetuates the planar nature of the electrolyte layer structure but results in vastly simplified separator plates.

The potential for volumetric power density improvement through more effective use of space within fuel cell stacks has begun to be recognized in prior designs in which bipolar separator plates are modified with the intention that they be more efficient. For instance Tsuru Atsushi et al., Japanese Patent Publication No. 9063599 A, published March 7, 1997" and Plowman, U.S. Patent No. 4,755,272 are representative of designs which employ corrugated separator plates that are inherently thinner than their conventional counterparts. All of these designs are based on the continued use of planar MEA structures which are clamped between bipolar plate elements.

Mitsuda, U.S. Patent No. 4,981,763, issued 1 January 1991, discloses the use of a static undulate electrolyte configuration, but his complete MEA (Figure 2) incorporates the undulate electrolyte layer within a

conventional planar electrode structure. Note that in Figure 14, although the electrolyte and adjoining catalytic layers are undulate, the electrode structure remains planar, and conventional.

A number of undulate electrolyte layer designs for high temperature molten carbonate fuel cells have been proposed, such as Fischer, et al., German Laid-Open Specification 25 14 034, Lemoine, German Laid-Open Specification No. 38 12813 A1, and Hiroshi Mihara, Japanese Patent Publication No. 1-292759. These designs recognize the inherent advantages of large scale undulations in the electrolyte layer within the fuel cell. These designs do not, however, suggest the use of PEM materials and do not disclose useful methods for the fabrication of PEM fuel cells employing undulate electrolyte layer configurations. Furthermore, these designs do not anticipate the use of undulate separators, nor do they describe any means of obtaining complex differential flowfields.

Disclosed in the prior technical literature are a number of fuel cell structures having non-planar elements. For example, Dodge, U.S. Patent No. 5,509,942, issued 23 April 1996, and Dodge, U.S. Patent No. 5,458,989 issued 17 October 1995, describe "tubular fuel cells", but do not suggest that the cells be contiguously oriented in a planar array forming a tier and do not suggest stacking such tubular arrays.

Nazmky, U.S. Patent No. 5,064,734, issued 12 November 1991, discloses a sinuously-formed current collector, for use between alternating separator plates and the membrane electrode assembly; he does not

disclose the use of a sinuous separator plate, nor the use of a sinuous MEA.

There are various sinuous configurations, or square-wave type configurations disclosed in the Furuya, U.S. Patent No. 5,618,392, issued 8 April 1997, but there appears to be no disclosure of a sinuous MEA, a sinuous separator, or interior flow channels.

McIntyre, U.S. Patent No. 4,826,554, issued 2 May 1989, discloses a sinuously-formed "electrically conductive, hydraulically permeable matrix 130, which is also embedded into the membrane sheet 120" (column 2, lines 33-35) and at line 40 we read that "The membrane may be a singular layer membrane of a composite layer membrane". However, there is no disclosure of alternating layers in a stack that contact one another to form interior flow conduits or channels.

Japanese Patent Publication No. 50903/1996, Futoshi et al., 20 February 1996, discloses a solid polymer fuel cell having generally planar separators with alternating protruding parts serving to clamp a power generation element (apparently an MEA) into a non-planar but piecewise linear shape. The area of the MEA exposed to reactants is increased relative to planar MEA designs, but the portions of the MEA clamped between the protruding parts and the planar portion of each separator do not appear to be exposed to reactants. Further, significant clamping force appears to be required to reduce contact resistance. Such force, together with the abrupt changes in direction at the corners of the protruding parts, may introduce kinks and very large stresses in the MEA.

An optimal design for a fuel cell stack should have at least the following characteristics:

(1) The conductive path between the anode plate of each unitary cell and the cathode plate of the next unitary cell in the stack should have as low an electrical resistance as possible.

(2) The contact resistance between the anode and cathode plates and the MEA should be as low as possible without requiring large mechanical clamping forces.

(3) As much of the electro-catalyst as possible should be uniformly exposed to reactants.

(4) The flow of reactants should be appropriate to the capacity of the cell to utilize the reactants in the electrochemical reaction.

(5) There should be no substantial short circuit (unwanted flow channel cross-over or leak) of fluid movement between adjacent fluid flow channels carrying the same reactant gas, and of course no short circuit whatsoever between flow channels carrying different reactant gases.

(6) Power density should be maximized (volume and weight per unit of power generated should be minimized).

As discussed above, conventional PEM fuel cell designs are not optimal if considered on the above basis, in part because (1) significant portions of the electro-catalyst layer are not efficiently exposed to reactants;

and (2) large clamping forces are required to reduce contact resistance, both of which factors decrease power density and tend to add to the expense of manufacture.

SUMMARY OF THE INVENTION

In the following description and in the claims:

(i) the "flow dimension" or "axial dimension" is perpendicular to the plane of each drawing;

(ii) the "stack dimension" is the direction of assembly of the series of fuel cells in the stack, perpendicular to the planes of the end plates of the stack; and

(iii) the "transverse dimension" is perpendicular to both the flow and stack dimensions.

Also, the undulate or wavy shape of various non-planar strata within fuel cells according to the invention is in part described using terminology normally used to describe wave motion, such as "waveform", "phase", "amplitude", and "period". The use of such terminology is not meant to suggest motion; the waveform of an undulate stratum or layer is that of a static structure.

In essence, the present invention is based upon the inventors' insight that the MEA strata in a PEM fuel cell need not be planar and that a non-planar MEA stratum design facilitates the design of PEM fuel cells that have useful implementations of the characteristics of an optimal fuel cell stack discussed above. Some of the structures found to be useful for non-planar MEA designs may also be useful in planar MEA designs (which

planar MEA designs may not have all of the characteristics of an optimal fuel cell, but may nevertheless offer advantages over conventional designs). However, for convenience of expression the following discussion first summarizes the present invention from the standpoint of its application to non-planar MEA fuel cell stack designs. A brief discussion of its application to planar MEA designs then follows. Finally, specific aspects of the invention are summarized in greater detail.

A primary consequence of a fuel cell having non-planar MEA strata is that instead of relying primarily upon channels in the separator plates to provide reactant gas flow conduits, relatively large portions of the MEA strata may be shaped to serve as walls for reactant gas flow conduits, thereby exposing a relatively large surface area of the MEA electrocatalytic layer to reactant gases. In its simplest aspect, the resulting structure geometrically resembles corrugated cardboard, the MEAs being configured as corrugated strata sandwiched between planar separator strata.

However, conventional MEA material is not sufficiently rigid to maintain a non-planar configuration when compressed between planar separator plates with sufficient force to make good electrical contact with the separator plates and to prevent an unacceptable level of leakage between the conduits. Either the MEA material has to be modified by strengthening it and possibly physically and electrically attaching it to the separator plates or strata, or else the separator strata have to be modified

so as to provide adequate support and contact with the non-planar MEA strata without the use of large compressive forces. In both cases, the inventors have found that the addition of reactant gas-permeable current collectors to either the separator strata or the MEA strata provides a satisfactory result. The inventors' current collectors may be either (1) attached to the separator strata or (2) combined integrally with the MEA strata to form a bonded non-planar layered MEA structure that may, if necessary, be physically attached and electrically connected to the separator strata. In the former case, the compression force needed is greatly reduced, as electrical contact between the separator strata and the conventional MEA material is spread over the entire surface of the MEA material by the current collectors. In the latter case, if the current collectors are attached, the compression force needed to hold the stack together is greatly reduced, because the separator strata and electrodes no longer need to be forced together to reduce contact resistance and prevent leakage; force is required only to counteract the internal pressure of the reactant gases. If, in the latter case, the current collectors are not attached to the separator strata, the expected inherent springiness of an undulate bonded layered MEA structure may provide adequate electrical contact between the MEA and the separator strata at its points of contact with the separator strata when the compression force needed to hold the stack together is applied.

Each separator stratum has a unique current collector attached to each of its two sides ("side" meaning one of the two working surfaces lying generally perpendicular to the stack dimension, although non-

planar separators may be designed and used, as will be described below). The current collectors are each either (1) a separate rigid structure in intimate contact with the MEA or (2) one element of an integral bonded layered structure also comprising a current collector attached to the next separator stratum in the stack, an ion exchange membrane, and electro-catalyst particles (and possibly porous material) between the membrane and the current collectors. In the former case, conventional flexible MEA sheet material may be placed between facing sides of successive separator strata and formed into a non-planar configuration by squeezing the current collectors together in the stacking dimension as the stack is assembled. In the latter case, the composite layered MEA structure is formed in place and is the electrochemical equivalent of conventional MEA material. The current collectors in the layered MEA structure may replace the electrode layers of a conventional MEA. In the following discussion, the phrase "layered MEA structure" means either (1) a conventional sheet of MEA material sandwiched between two non-planar current collectors or (2) an ion exchange membrane, electro-catalyst particles, and possibly porous material sandwiched between two non-planar current collectors so as to form the electrochemical equivalent of a conventional MEA.

As in a conventional fuel cell stack, in embodiments of the present invention each separator plate or stratum must also provide electrical connection between the sites of electrochemical activity on opposed sides of the separator stratum. In a conventional fuel cell, the separator plate is conductive and is in electrical contact with the MEAs on its opposed sides.

In accordance with the present invention, each current collector is conductive, collects electrons from one side of the layered MEA structure, and conveys the electrons to the separator stratum to which it is attached. The separator strata are either electrically conductive or otherwise provide electrically conductive paths between attachment points of the current collectors on their opposed sides so as to electrically connect those current collectors.

The resulting stacked configuration of separator strata alternating with attached non-planar layered MEA structures will produce a flow of electrical current through an external circuit connected between current collectors at the ends of the stack that are opposed in the stack dimension if reactant gases flow through the conduits formed between the separator strata and the non-planar layered MEA structures. One end of each conduit must be connected to a source of reactant gas and the other to a sink of reactant gas to provide the necessary flows of reactant gas through the conduit. The preferred manifolding of reactant gas into and out of the conduits is within the designer's discretion and not *per se* a part of this invention.

The conduits on opposed sides of each layered MEA structure carry the reactant gases, fuel on one side and oxidant on the other side. As the layered MEA structures and separator strata are both reactant gas-impermeable, conduits having any desirable configuration may be formed by patterns of attachment of the layered MEA structures and the separator strata. For example, if the layered MEA structures are corrugated in the transverse dimension and attached along their parallel

ridges and hollows to the separator strata, then an array of parallel conduits are consequently formed running (oriented) in the axial or flow dimension.

Included within the scope of the invention are fuel cell stacks having planar layered MEA structures combined with non-planar separator strata. Conduits formed between planar layered MEA structures and non-planar separator strata necessarily expose less of the surface area of the layered MEA structure to reactants than conduits formed between non-planar layer MEA structures and planar separator strata. However, the compression force in the stack dimension needed to reduce contact resistance and prevent leakage is still reduced as compared to conventional fuel cell stack designs incorporating planar MEA.

As a further example, fuel cell stacks having separator strata and layered MEA structures topologically equivalent to those of the corrugated structure discussed above, such as those in which both the layered MEA structures and the separator strata are non-planar or in which the layered MEA structures are shaped so that conduits vary in cross-section, are within the scope of the invention. Conduits for one reactant may, for example, differ in cross-sectional area from conduits for the other reactant or the separator strata may be undulate with the same phase and period as the layered MEA structures, but with a lower amplitude, so as to provide conduits which, when combined with the undulate layered MEA structures, may increase the power density of the stack by constricting the size of the conduits while maintaining the same area of MEA exposed to reactants, thus reducing the overall

thickness of the fuel cell stack while maintaining the same power output.

More specifically, one embodiment of the present invention is a fuel cell stack having a plurality of separator strata, a plurality of undulate reactant gas-permeable electrically conductive current collectors, and a plurality of reactant gas-impermeable ion-exchange membranes. Each separator stratum is impermeable to reactant gases, spaced apart from each other separator stratum in the stack dimension, and extends generally in dimensions perpendicular to the stack dimension. Each current collector also extends generally in dimensions perpendicular to the stack dimension. Each membrane is sandwiched between a unique associated pair of spaced-apart current collectors. Electro-catalyst particles are spread between the membrane and each current collector so that the membrane and electro-catalyst particles fill the space between the current collectors, forming together with the current collectors an undulate layered MEA structure. The layered MEA structures and separator strata alternate with each other in the stack dimension so that each layered MEA structure is disposed between an associated pair of separator strata so as to form at least one discrete plenum on each side of the layered MEA structure through which plenum a reactant gas may be circulated. Each separator stratum is attached to and provides an electrically conductive path between the current collectors of the layered MEA structures on either side of the separator stratum.

Layered MEA structures may be formed in a variety of ways. Conventional MEA material may be used in which the membrane has been coated with electro-catalyst

particles and flexible or preformed electrically conductive porous layers bonded to opposite sides of the electro-catalyst coated membrane. A discrete sheet of the resulting conventional MEA material is then placed between the current collectors of each layered MEA structure and moderate clamping pressure applied between the ends of the fuel cell stack to conform the conventional MEA material to the shape of the current collectors. Alternatively, the electro-catalyst coated membrane and associated pair of current collectors of each layered MEA structure may be bonded together directly without interposed porous layers.

Rather than coating the membrane with electro-catalyst particles, the side of each current collector that will face the membrane may be coated with electro-catalyst particles and then the membrane and associated pair of electro-catalyst coated current collectors of each layered MEA structure may be bonded together directly. Alternatively, a gel membrane material may be used, preferably in conjunction with a coarse non-conductive mesh disposed between the pair of electro-catalyst coated current collectors of the layered MEA structure so that the gel is disposed in the interstices of the mesh and also fills the pores of the current collectors.

As a further alternative, the side of each current collector that will face the membrane may, before assembly into a layered MEA structure, be coated first with a porous conductive layer and then further coated with the electro-catalyst particles. The layered MEA structure may then be assembled by bonding the membrane and associated pairs of coated current collectors

together.

The current collectors may be attached to the separator strata in a variety of ways depending upon the material used for the current collectors and separator strata. The separator strata may be made of conventional printed circuit board material with traces serving as attachment points for the current collectors.

The current collectors may then be soldered to traces on the circuit board and electrical connection between the current collectors on opposite sides of the circuit board provided by holes that pass through the circuit board and traces and that have been filled with conductive material. Alternatively, the current collectors may be attached to a separator stratum by stitching the current collectors on opposite sides of the associated separator stratum together through the separator stratum using thread. If the separator stratum is a conductor, the thread may be chosen to provide the best mechanical bond and need not be conductive. If the separator stratum is a non-conductor, then the thread should provide electrical conductivity as well as mechanical bonding. A seal is provided around the stitches to prevent leakage.

Alternatively, non-metallic current collectors may be bonded to a non-metallic separator stratum by conductive bonds. When both the current collectors and the separator strata contain metallic components, then welding, brazing or soldering techniques may be used to attach the current collectors to the separator strata.

If the current collectors are non-metallic, but the separator strata contains metallic components, welding, brazing or soldering techniques may be used by adding auxiliary metal plates on top of the current collectors

over the regions of the separator strata to which the current collectors are to be attached and welding, brazing or soldering the plates through the current collectors to the separator strata.

It is also an aspect of the invention to use hydrogen in a fuel cell stack that is made up of fuel cells comprised of separator strata alternating with layered MEA structures as heretofore described and that is connectable via an anode terminal and a cathode terminal to an external load. Each fuel cell has a discrete MEA structure and two associated reactant-gas impermeable separator strata. The MEA structure has a porous anode electrode, a porous cathode electrode, an electrolytic membrane layer disposed between the two electrodes, an anode electro-catalyst layer disposed between the electrolytic membrane layer and the anode electrode, and a cathode electro-catalyst layer disposed between the electrolytic membrane layer and the cathode electrode. One side of one separator stratum in conjunction with the MEA structure provides at least one flowpath of a flow field for hydrogen and one side of the other separator stratum in conjunction with the MEA structure provides at least one flowpath of a flow field for a selected oxidant. The flowpaths are constituted over their greater length by parallel transversely spaced and longitudinally extending flow channels interconnected in the vicinity of their ends to form the flowpaths.

The MEA structure is installed in the stack between the associated separator layers so that the side of the separator stratum that in conjunction with the MEA layer provides flow channels of a flow field for hydrogen

faces and is in contact with the anode side of the MEA structure, whilst the side of the separator stratum providing flow channels of a flow field for oxidant faces and is in contact with the cathode side of the MEA layer, so that the hydrogen flow channels are closed to form a conduit for supplying hydrogen to the MEA structure and the oxidant flow channels are closed to form a conduit for supplying oxidant to the MEA structure.

The fuel cells are stacked in sequence, the anode electrode of the fuel cell at one extremity of the stack being electrically connected to the anode terminal, the cathode electrode of the fuel cell at the other extremity of the stack being electrically connected to the cathode terminal, and the anode electrode of each of the other fuel cells in the stack being electrically connected to the cathode electrode of the next adjacent fuel cell. When the anode terminal and cathode terminal are electrically connected through an external load and for each fuel cell hydrogen is supplied to the hydrogen conduit and oxygen is supplied to the oxidant conduit, then in each fuel cell hydrogen moves from the hydrogen flow field through the anode electrode and is ionized at the anode electro-catalyst layer to yield electrons and hydrogen ions, the hydrogen ions migrate through the electrolytic membrane layer to react with oxygen that has moved from the oxidant flow field through the cathode to the cathode electro-catalyst layer and with electrons that have moved from the anode electrode electrically connected to the cathode electrode, thereby to form water as a reaction product, and a useful current of electrons is thereby produced through the load.

BRIEF DESCRIPTION OF THE DRAWINGS

Figure 1 is a schematic cross-sectional view of a portion of a conventional planar MEA fuel cell stack, taken perpendicular to the direction of reactant flow.

Figure 2 is a schematic cross-sectional view of a portion of a fuel cell stack that is an embodiment of the present invention, taken perpendicular to the direction of reactant flow.

Figure 2A is a schematic exploded cross-sectional view, taken perpendicular to the direction of reactant flow, of a flattened representative portion of a first variant of the undulate layered MEA structure of the fuel cell stack of Figure 2.

Figure 2B is a schematic exploded cross-sectional view, taken perpendicular to the direction of reactant flow, of a flattened representative portion of a second variant of the undulate layered MEA structure of the fuel cell stack of Figure 2.

Figure 2C is a schematic exploded cross-sectional view, taken perpendicular to the direction of reactant flow, of a flattened representative portion of a third variant of the undulate layered MEA structure of the fuel cell stack of Figure 2.

Figure 2D is a schematic exploded cross-sectional view, taken perpendicular to the direction of reactant flow, of a flattened representative portion of a fourth variant of the undulate layered MEA structure of the

fuel cell stack of Figure 2.

Figure 2E is a schematic exploded cross-sectional view, taken perpendicular to the direction of reactant flow, of a flattened representative portion of a fifth variant of the undulate layered MEA structure of the fuel cell stack of Figure 2.

Figure 3 is a schematic cross-sectional view of a portion of a fuel cell stack that is a further embodiment of the present invention in which the separator strata are sinuous, having a wave-shape that differs from the wave-shape of the layered MEA structure in amplitude, taken perpendicular to the direction of reactant flow.

Figure 3A is a schematic cross-sectional view of a portion of a fuel cell stack that is a further embodiment of the present invention in which the separator strata are composed of planar portions angled to one another, forming a generally undulate structure, and having a wave-shape with the same period as the wave-shape of the layered MEA structure, taken perpendicular to the direction of reaction flow.

Figure 4 is a schematic cross-sectional view of a portion of a fuel cell stack that is a further embodiment of the present invention in which the layered MEA structure is comprised of a continuous series of alternating semicylinders having two different radii, taken perpendicular to the direction of reactant flow.

Figure 4A is a schematic cross-sectional view of a portion of a fuel cell stack that is an embodiment of

the present invention in which the layered MEA structure is comprised of asymmetrical periodic shapes, taken perpendicular to the direction of reactant flow.

Figure 5 is a fragmentary schematic cross-sectional view of a cell skeleton of the fuel cell stack of Figure 2.

Figure 6 is a fragmentary schematic cross-sectional view of a portion of a variant of the fuel cell stack of Figure 2 illustrating a first method of attachment of the MEA layer screens to the separator strata.

Figure 7 is a fragmentary schematic cross-sectional view of a portion of another variant of the fuel cell stack of Figure 2 illustrating a second method of attachment of the screens to the separator strata.

Figure 8 is a fragmentary schematic cross-sectional view of a portion of another variant of the fuel cell stack of Figure 2 illustrating a third method of attachment of the screens to the separator strata.

Figure 9 is a fragmentary schematic cross-sectional view of a portion of another variant of the fuel cell stack of Figure 2 illustrating a fourth method of attachment of the screens to the separator strata.

DETAILED DESCRIPTION OF THE INVENTION

To provide a working fuel cell stack taking advantage of the increased power density capable of being provided by undulate or wave-like MEA strata rather than planar MEA strata, it is necessary to (1)

maintain the dimensional stability of the MEA strata in their undulate or wave-like shapes, (2) separate flowing oxidant on the cathode side of one MEA from flowing fuel on the anode side of the next MEA in the stack, and (3) provide electrical connection between the cathode side of one MEA and the anode side of the next MEA in the stack. In general the MEA structures discussed in detail below meet these three requirements by providing MEA strata that are non-planar and the separator strata are either planar or non-planar; reactant conduits or plenums that are formed between the MEA strata and the separator strata.

In the embodiments of MEA structure according to the present invention to be described below, the electrochemical process employed is conventional; the MEA structural aspects of the invention are directed to the configuration of the elements described, not to their electrochemical activity.

The MEA stratum employed in the invention to be described may be, in a first embodiment, a conventional flexible layered structure comprising a membrane sandwiched between two porous electrode layers with electrocatalytic material at each electrode layer/membrane interface, or preferably may be, in a second embodiment, an unconventional layered structure according to a further aspect of the invention that includes current collectors that may act both as electrodes and as structural elements attached to the separator strata. In the second embodiment mentioned above, the membrane is formed in place in an unconventional manner according to a further method aspect of the invention, to be described. In both

embodiments of the invention, the membrane is not planar in the assembled fuel cell stack. The membranes in the two embodiments in their basic spatial characteristics are topologically equivalent.

The overall structure of a fuel cell stack in accordance with an embodiment of the present invention is illustrated in Figure 2. In Figure 2, which provides a schematic axial cross-sectional fragmentary view of a portion of a fuel cell stack, generally indicated by reference numeral 10, the stack 10 comprises a plurality of undulate reactant gas-impermeable layered MEA structures, generally referred to by reference numeral 25 in the following discussion, and a plurality of reactant gas-impermeable separator strata, generally referred to by reference numeral 20 in the following discussion. The layered MEA structures 25 and separator strata 20 are alternately disposed in the stack 10 so that each layered MEA structure 25 is disposed between an associated pair of separator strata 20. Where necessary for clarity of exposition separator strata 20 and layered MEA structures 25 are individually indicated in the drawings by reference numerals with appended letters.

The separator strata 20 and the layered MEA structures 25 extend in the axial dimension (perpendicular to the plane of Figure 2), maintaining throughout such extension the cross-sectional configuration shown in Figure 2. As the separator strata 20 and the layered MEA structures 25 are each impermeable to reactant gases, parallel oxidant conduits 28 and fuel conduits 30, whose axial or reactant flow dimension is perpendicular to the plane of Figure 2, are

formed through which the respective reactant gases may be circulated.

Five alternative internal structures for the layered MEA structure 25 are described in detail below in relation to Figures 2A, 2B, 2C, 2D, and 2E; details shown in Figures 2A, 2B, 2C, 2D, and 2E that are not common to each alternative are omitted from Figure 2.

Two elements common to each alternative are reactant gas-impermeable ion-exchange membranes 14 and reactant gas-permeable conductive current collectors such as thin undulate screens 22, 24. Each membrane 14 has a cathode side or surface 16 and an anode side or surface 18 and is constrained in an undulate shape by the screens 22, 24. Each of the screens 22, 24 is attached at attachment points 26 to a unique one of the pair of separator strata 20 between which the membrane 14 is disposed. As is the case with the separator strata 20 and the layered MEA structure 25, the membranes 14 and screens 22, 24 extend in the axial dimension, maintaining throughout such extension the cross-sectional configuration and relative attachment position shown in Figure 2. Where necessary for clarity of exposition, the membranes 14 and the screens 22, 24 are individually indicated in the drawings by reference numerals with appended letters. For example, in Figure 2, membrane 14A is disposed between screen 24A, which is attached to separator stratum 20A, and screen 22A, which is attached to separator stratum 20B. Here the exemplary separator strata 20 are planar. In the following discussion, the current collectors are generally referred to as "screens" by way of example and for convenience of exposition, but it should be understood that other reactant gas-permeable structures

may be used as well. A detailed discussion of the materials that may be used as screens 22, 24 and of methods for constructing screens 22, 24 and attaching them to separator strata 20 is found below.

Figures 2, 3 and 4 each show physical attachment of the screens 22, 24 to the separator strata 20 at attachment points 26. However, it is expected that the undulate layered MEA structures 25 will be inherently springy when subjected to pressure in the stacking dimension, so that, depending upon the materials chosen and the dimensions of the structure, physical attachment at attachment points 26 may not be necessary in order to obtain adequate physical and electrical contact between the layered MEA structures 25 and the separator strata 20. The need for attachment would be empirically determined in any particular fuel cell design. Electrical and physical contact between layered MEA structures 25 and the separator strata 20 and dimensional and shape stability of the layered MEA structures 25 is what is essential.

A conventional planar MEA fuel cell stack is illustrated in Figure 1 and indicated generally by reference numeral 11. In stack 11 planar MEAs 15 are alternately disposed between bipolar flow plates 19. The flow plates 19 are provided on each side with lands 43 constituting channel walls between which reactant gas flow channels 39, 41 are formed. The lands 43 contact the MEAs 15 at contact areas 45. Functionally, the layered MEA structures 25 and separators 20 of Figure 2 correspond to the MEAs 15 and flow plates 19 of Figure 1, respectively.

Figures 2A, 2B, 2C, 2D, and 2E illustrate idealized exploded schematic fragments of alternative layered MEA structures 25. The relative thickness and spacing of the elements of each fragment have been selected in Figures 2A, 2B, 2C, 2D, and 2E only for ease of illustration of the relative order of those elements; when assembled there are no spaces between the layers of the layered MEA structures. As well, for convenience the fragments are shown as cross-sections of planar structures, whereas the layered MEA structures 25 shown in Figure 2 are non-planar, except approximately locally. In each alternative layered MEA structure 25, in addition to membrane 14 and the screens 22, 24, electrocatalytic particles 27 are disposed at the interface between each cathode side 16 of the membrane 14 and associated screen 22 and at the interface between each anode side 18 of the membrane 14 and associated screen 24. In Figures 2A, 2B, 2C, 2D, and 2E, the layered MEA structures 25 are indicated by the reference numeral 25 with an appended letter to distinguish between the alternatives. Briefly, the alternative layered MEA structures 25 have the following structures:

- (1) In Figure 2A, a conventional MEA 31 sandwiched between screens 22, 24 forms layered MEA structure 25A. The MEA 31 of the layered MEA structure 25A is not attached to the screens 22, 24, but is held in physical and electrical contact with the screens 22, 24 when the fuel cell stack 10 is assembled by clamping force in the stacking dimension as discussed below. MEA 31 may be formed in a conventional manner from two porous conductive electrode layers 29 that have each been coated on one side with

electrocatalytic particles 27 and the coated side of one bonded to side 16 of the membrane 14 and the coated side of the other bonded to side 18 of membrane 14.

- (2) In Figure 2B, the sides 16, 18 of the membrane 14 have been coated with electrocatalytic particles 27 and the coated membrane 14 bonded directly to screens 22, 24 to form layered MEA structure 25B. Coating and bonding techniques are described in further detail below.
- (3) In Figure 2C, the screens 22, 24 have been coated with electrocatalytic particles 27 and bonded directly to membrane 14 to form layered MEA structure 25C. Coating and bonding techniques are described in further detail below.
- (4) In Figure 2D, the screens 22, 24 have been coated with electrocatalytic particles 27 using techniques described in detail below. The membrane, indicated by bracket 14 in Figure 2D, is a gel 33 disposed in the interstices of a coarse non-conductive mesh 35 disposed between the screens 22, 24 to form layered MEA structure 25D.
- (5) In Figure 2E, the side of each screen 22, 24 that will face the membrane 14 is coated with a porous conductive layer 47 and then coated with electrocatalytic particles 27. The coated screens 22, 24 are bonded directly to membrane 14 to form layered MEA structure 25E.

Coating and bonding techniques are described in further detail below.

A more detailed discussion of methods for construction of the layered MEA structures 25 is found below.

Of the five alternative layered MEA structures 25A, 25B, 25C, 25D, and 25E discussed above, only the layered MEA structure 25A illustrated in Figure 2A uses conventional composite-layered MEA sheet material. In that design, the screens 22, 24 augment the function of the porous electrode layer 29 of the conventional MEA 31 by collecting and transferring electrons to the separator strata 20 and also conform the MEA 31 to the desired non-planar configuration, acting as an extensions of the separator strata 20 to which they are attached. In the four designs illustrated in Figures 2B, 2C, 2D, and 2E, the screens 22, 24 replace the porous electrode layer 29 of the conventional MEA 31 in the role of conducting electrons to or from the electrocatalytic particles 27, in effect functioning both as electrodes and as extensions of the separator strata 20.

The separator strata 20 may be made of conventional materials chosen for the manufacture of separator plates in conventional fuel cells. However, the strata 20 need not be entirely electrically conductive if conductive paths, schematically indicated by line 34 in Figure 2, are provided between the attachment points 26 of screens 22, 24 attached to opposite sides of the associated separator stratum 20. For example, in Figure 2, screen 22A is electrically connected to screen 24B by the two exemplary conductive paths 34 that pass through the

separator stratum 20B, it being understood that conductive paths 34 would be provided along each line of contact of screens 22 and 24 with associated neighbouring separator strata 20. In the following discussion, unless otherwise stated, the separator strata 20 are assumed to be composed of conductive material, in which case separately designed and manufactured conductive paths 34 are not required.

As the screens 22, 24 are permeable to reactant gases, the electrocatalytic particles 27 will be exposed to reactant gases flowing through the conduits 28, 30.

The conventional electrochemical processes will occur in the vicinity of the electrocatalytic particles 27 and electrons will collect on the screens 24. If an external circuit (not shown) is provided that conventionally connects together the terminal screens 22, 24 at the extremities of the stack 10 in the stack dimension, then a current of electrons will flow through that external circuit. For example, if the portion of stack 10 shown in Figure 2 were an entire fuel cell stack comprising precisely two fuel cells, a current would flow from screen 24A to screen 22B if those screens were connected by an external circuit and reactant gases were flowing through the appropriate conduits 28, 30.

Operation of fuel cell stack 10 requires that appropriate seals be provided along the transverse edges of the stack 10 (not shown in Figure 2). The principles of design of the needed reactant gas flow manifolds, seals, and external electrical circuits are known to those skilled in the art. Their selection in conjunction with the structures of the present invention

is within the designer's discretion. Such selection is outside the scope of the present invention.

Only a small portion of fuel cell stack 10 is shown in Figure 2 - an exemplary two fuel cells out of several dozen fuel cells usually installed in a typical stack.

In a practical fuel cell stack 10, many more layered MEA structures 25 would be provided, each of which would extend in the transverse direction through many more undulations than are illustrated in Figure 2. Further, at the extremities of the fuel cell stack 10 in the stack dimension, end plates (not shown, but functionally similar for current collection and transmission purposes to separators 20A and 20C in Figure 2) would be needed to complete the fuel cell stack 10. The fragment of stack 10 shown in Figure 2 does, however, illustrate the essential structural elements of the first embodiment of the undulate layered MEA structure of the present invention described herein.

Each layered MEA structure 25 together with the associated separator strata 20 to which it is attached is generally referred to below as a unitary fuel cell 32; the two such cells shown in Figure 2 are referred to by reference numerals 32A and 32B. It should be noted that in the embodiment shown in Figure 2, unitary fuel cell 32A shares separator stratum 20B with unitary fuel cell 32B, although as described in applicant's British Patent Application Serial No. 9814120.3 (filed on 1 July 1998) and derivatives and divisionals thereof, it may be advantageous for each unitary fuel cell 32 to have a discrete pair of non-planar separators so that coolant conduits may be built-up between the separators of successive fuel cell layers.

While illustrated in Figure 2 as planar sheets, the separator strata 20 may optionally be non-planar sheets and may optionally have internal structure. Specific configurations can be chosen according to their suitability for particular designs. For example, as illustrated in Figure 3, the separator strata 20 may be undulate with the same phase and period as the layered MEA structures 25, but with a lower amplitude, so as to provide crescent-shaped flow channels 23 which, when combined with the undulate layered MEA structures 25, may increase the power density of the stack 10 by constricting the size of the flow channels 23 and thus reducing the overall thickness of the fuel cell stack 10. A second example of an undulate separator is shown in Figure 3A, in which non-sinusoidal separator strata are used to allow compression of the cells in the stack dimension while maximizing the exposure of the undulate MEA layer to reactant gases, thus creating a more desirable configuration than shown in Figure 3. Other configurations of undulate separators 20 and layered MEA structures 25 are possible. For example, arrangements in which the layered MEA structures 25 and separator strata 20 have the same period of undulation and are 180 degrees out of phase. However, such alternatives tend in many instances not to be the most space efficient available. Alternatively, the separator strata 20 may be undulate with waveform, phase, period, or amplitude varying transversely across or axially through the separator strata 20 (such optional undulate configurations are not illustrated), and may include internal interconnections for the passing of reactant gases between flow channels, as described in applicant's British Patent Application Serial No. 9814121.1 (filed on 1 July 1998) and derivatives and divisionals thereof.

Further, the separator strata 20 may be manufactured, as described in applicant's British Patent Application Serial No. 9814120.3 (filed on 1 July 1998) and derivatives and divisionals thereof, so as to provide internal coolant channels.

Generally, layered MEA structures 25 having a variety of transverse waveforms may be used in accordance with the present invention so long as adequate flows of reactant gases can reach the electrocatalytic particles 27. Figure 4 illustrates a design in which the conduits 30 have a larger cross-sectional area than the conduits 28 and therefore provide a greater flow of reactant gas. Figure 4A illustrates another alternative design in which the reaction conduits 28 and 30 differ in cross-sectional area and shape. Selection of an appropriate waveshape is based on design considerations including the desired pressure drop characteristics within the flowfield and contact resistance and is generally known to those skilled in the art.

In Figure 2, a waveform of alternating semicircles, each oriented 180° to its immediate contiguous neighbour, is employed, but other shapes (sinusoidal, for example) may be employed. For example, as illustrated in Figure 4, the radii of curvature of the semicircles that contact separator strata 20 may alternate between a larger and a smaller value if the designer considers it desirable that the cross-sectional areas of reactant conduits 30 be larger than the cross-sectional areas of reactant conduits 28. It is of course not necessary that semicircles be employed for these purposes; the sinuosity of the layered MEA structure 25 may be

designed and manufactured by any convenient means.

The conduits 28, 30 resulting from the use of the waveform of the layered MEA structures 25 shown in Figure 2 provide a plurality of flows of reactants in straight paths in the axial dimension, but other waveforms may be selected instead if the designer considers other reactant flow patterns to be desirable.

For example, the designer may wish to provide a flow pattern that enters and leaves the fuel cell stack 10 from the same transverse or axial side of the fuel cell stack 10 with a serpentine path in a plane perpendicular to the stack dimension between the inlet and outlet ports for the flowpath in question. Moreover, regularly spaced conduits 28, 30 arranged in a regular pattern as illustrated in Figures 2, 3, and 4 need not be used; instead the layered MEA structures 25 may be attached to the associated separator strata 20 at a pattern, or even a random arrangement, of discrete unconnected attachment points 26 thereby forming a single plenum having a convoluted surface between the layered MEA structures 25 and the associated separator strata 20 (such pattern and random arrangement are not illustrated).

As is apparent from an examination of Figure 2, for any spacing in the stack dimension between consecutive separator strata 20 associated with particular layered MEA structures 25, the area of the electrocatalyzed layered MEA structure 25 exposed directly to reactants is always larger than the surface area of the MEA that would be exposed to reactants in a conventional planar MEA fuel cell stack having the same separator plate spacing and dimensions. For example, in the fragment of conventional planar MEA fuel cell stack 11 illustrated

in Figure 1, the portion of the surface area of the interior of each conduit 41 constituted by the surface 16 of the MEA 15 is always less than the portion of that surface area constituted by the surface of the separator 19. The conduits 39, 41 in Figure 1 have square cross-sections, and the separator 19 forms three of the four sides of the square. So the conduit surface is formed $3/4$ by the separator 19 and $1/4$ by the MEA 15; no matter what the cross-sectional shape of the conduits 39, 41, the portion of the conduit surface formed by the MEA 15 is always less than the portion formed by the separator 19. On the other hand, in Figure 2, the portion of the surface area of interior of a conduit 28 that is constituted by the surface of the layered MEA structure 25 is always greater than the portion of that surface area constituted by the adjacent separator stratum 20. Quite clearly, the present invention provides improved access of reactant gases to the MEA.

Further, the area of the layered MEA structure 25 that is occluded by contact with the separator strata 20 in the embodiments of the invention illustrated in Figure 2 is relatively small as compared to the relatively large area of the MEA 15 occluded by surface contact with the contact areas 45 in the conventional planar MEA fuel cell stack 11 illustrated in Figure 1.

In the known non-planar MEA fuel cell stack design disclosed in Futoshi *et al.*, JPP 08-050903, the area of the MEA stratum exposed to reactants is reduced, as compared to that in the fuel cell stack 10 illustrated in Figure 2, by the areas of the MEA in contact with the protruding parts 6a and 7a shown in Figures 1 and 2 of Futoshi. No such protruding parts are needed in the

fuel cell stack 10 shown in Figure 2, as the screens 22, 24 and separators 20 provide dimensional stability to the membrane 14 and electrical connection between layered MEA structures 25. Furthermore, the presence of Futoshi's protrusions 6a, 7a undesirably reduces the space otherwise available for reactant gas flow. It should be noted that the Futoshi fuel cell is similar to the conventional planar MEA cell of Figure 1, except that the flow plates have been transversely offset and compressed together in the stack dimension relative to the conventional structure so as to reshape the MEA into a non-planar shape. The general conventional need for high clamping forces in order to reduce contact resistance and leakage between conduits carrying the same reactant does not appear to be alleviated in Futoshi's design, although the area of the MEA exposed to reactants would seem to have been increased somewhat over conventional planar designs. Further, in the Futoshi design, the abrupt changes in direction of the MEA at the corners of the protruding parts 6a, 7a may introduce large stresses in the MEA, possibly causing the MEA to crack. The present applicant's continuously curved MEA tends to be crack-resistant and dimensionally stable, as well as facilitating maximum exposure of MEA to reactant gases.

The fuel cell stack 10 shown in Figure 2 may be assembled by first constructing a plurality of cell skeletons, which are shown in detail in Figure 5 and generally indicated by reference numeral 12. Each cell skeleton 12 comprises a separator stratum 20 and two attached screens 22, 24. The details of the materials and construction techniques needed to construct cell skeletons are now discussed in detail with reference to

Figures 5 - 9, following which assembly of fuel cell stacks in accordance with the invention by the addition of either conventional or unconventional membranes 14 to form layered MEA structures 25 is discussed in detail.

Optionally, the separator strata 20 are comprised of conventional printed circuit board material, in which case electrical connection between the screens 22, 24 on opposite sides of a given printed circuit board separator 20 must be arranged, as will be discussed in detail below. The screens 22, 24 can be made of expanded metal mesh, preferably made of 316L stainless steel. Other materials may also be used, such as graphite plate, graphite foil, metal plate, or metal foil for the separator strata 20, and carbon cloth or woven metal screen for the screens 22, 24. Structurally similar materials that are non-conductive may also be used for the interior of screens 22, 24 so long as they remain permeable to reactant gases when made conductive through the application of an exterior conductive surface coating by metal plating, carbon coating, or the application of conducting polymers.

The sheet material out of which the screens 22, 24 are formed can be made into an undulate layer of the desired wavelength and amplitude by stamping, rolling or pressing.

In the cell skeleton 12 shown in Figure 5, the waves or undulate shapes into which the screens 22, 24 have been formed are respectively out of phase with one other by 180 degrees. Any preferred relative phase relationship can be obtained between the undulate screens 22, 24, although the out-of-phase alignment

facilitates some cell skeleton assembly methods because the attachment points 26 for the screens 22, 24 may then be at directly opposed sites on opposite sides of the separator strata 20 as shown in Figure 5.

A wide variety of waveforms may be employed for the shape of the screens 22, 24. The remaining portions of the layered MEA structure 25 are then added (as will be described in detail below) to conform to the starting shape of the screens 22, 24, thereby making it possible to form the layered MEA structure 25 into waveforms that, compared with prior conventional designs, reduce stress on the membranes 14 by reducing the clamping force on the stack 10 and increase energy density by increasing the exposure of the electrocatalytic particles 27 to reactant gases. In both of the foregoing respects, undulate MEAs built on and conforming to undulate screens 22, 24 offer advantages over the structures described and illustrated in the previously identified published Japanese patent specification of Futoshi *et al.*

In the preferred design for cell skeleton 12 using printed circuit board for the separator stratum 20, the substrate 21 of the printed circuit board separator stratum 20 illustrated in Figure 6 is made of rigid fibreglass, resin, or of flexible plastics materials such as TEFLON™ or MYLAR™. Electric circuit traces are formed on the surface of the substrate 21 using standard methodology and practice for the construction of printed circuit boards. As illustrated in Figure 6, the circuit traces 36, 37 on each surface of the substrate 21 are electrically connected with each other through a conductively filled hole or via 38, which is first

drilled and then plated and filled with conductive material 40. The undulate screens 22, 24 are soldered, welded, or otherwise electrically and physically connected to the circuit traces 36, 37 on either side of the substrate 21, the trace 36 providing the required electrically conductive path from screen 24 through the conductive material 40 in the via 38 to the trace 37 to the other screen 22.

The use of printed circuit board techniques also allows the designer the freedom to vary the relative phase of the screens 22, 24, because the screens 22, 24 can be soldered to the substrate 21 from one side at a time. The portions of the traces 36, 37 to which the screens 22, 24 are soldered need not be at directly opposed locations on the sides of the substrate 21, with interposed printed circuit connections as required. An example of the foregoing possibility appears in Figure 6.

Traces 36, 37 may be used to connect screens 22, 24 that have an arbitrary phase relationship with each other. For example, in Figure 6, the screens 22 and 24 are shown as not quite completely out of phase. As another example, this method of construction can be applied to the embodiment illustrated in Figure 3 in which the screens 22, 24 are in phase (by making use of relatively long traces 36, 37 extending transversely about one-half the transverse distance of a half-wave of the undulate pattern) as well as to the embodiment illustrated in Figure 2 in which the screens 22, 24 are completely out of phase, thus requiring the shortest traces 36, 37.

The traces 36, 37 extend axially along the lines formed by the attachment points 26 and may also extend transversely at the discretion of the designer.

For example, the traces 36, 37 may extend transversely so that when viewed from above the pattern of traces 36, 37 on the separator stratum 20 resembles a square lattice.

The use of printed circuit board technology in the manufacture of separator strata 20 is advantageous because it is possible to create traces 36, 37 onto which the screens 22, 24 can be soldered that are very narrow transversely. Narrow traces 36, 37 minimize the amount of exposed metal as the traces are metallic; exposed metal can shorten cell lifetimes in two ways.

First, the metal itself may corrode, which can cause premature failure of the structure. Second, metal ions may be deposited into the catalyst layer, causing catalyst sites to become "clogged" with metal ions and ultimately "choking" the cell. Further, narrow traces 36, 37 allow for simple alignment of the screens 22, 24 in the manufacturing stage by the use of the surface tension of molten solder to draw the screens 22, 24 into alignment when the screens 22, 24 are soldered in place using solder paste and heating in an oven, a well known and frequently exploited technique used in wave soldering manufacturing of surface mount components on printed circuit boards. Also, large-scale circuit-board manufacture is a well-developed technology. A further benefit of using printed-circuit-board technology arises from the possibility of embedding electronic components within the fuel cell stack 10. By using multi-layer circuit-board technology, active circuit elements can be included inside the cell. For example, sensors (not

shown) such as temperature or humidity sensors could be mounted on the substrate 21. The circuits (not shown) required to connect these sensors to monitoring equipment outside of the fuel cell may be formed as secondary circuits on the printed circuit board substrate 21. This printed circuit board manufacturing method may be extended to include small electronically controlled gas valves mounted to the substrate 21 and protruding within flow conduits 28, 30 so that dynamic control of gas flow within the fuel cell stack 10 is possible, allowing the active area of each unitary fuel cell 32 in the stack 10 and the overall flow-field geometry to be changed dynamically.

Welding or soldering may be employed to attach the screens 22, 24 to the separator strata 20. It is preferable to gold- or platinum-plate the metallic components of the completed cell skeleton 12 after attachment of the screens 22, 24 to the separator stratum 20 to reduce the risk of corrosion. Alternatively, a thin layer of conductive polymer material, such as polyaniline, may be applied to the metallic components of the completed cell skeleton 12 to provide a corrosion-resistant protective layer.

An alternative method of attaching the screens 22, 24 to the separator by stitching the screens 22, 24 together through the separator 20 is illustrated in Figure 7. The screens 22, 24 are preferably placed 180° out of phase with each other on either side of the separator 20 and a thread 44 is stitched from one side to the other to provide the desired mechanical connection of the screens 22, 24 to the separator 20.

In the case of a conducting separator 20 made of

material like graphite plate or foil or metal, the thread 44 may be chosen to provide the best mechanical bond and need not be conductive. In the case of a non-conducting separator 20 made of material like TEFLON™, fibreglass or MYLAR™, the thread 44 should provide electrical conductivity as well as mechanical bonding, and accordingly should be made of conductive filamentary material such as a carbon fibre material.

The task of stitching the cell skeleton 12 together is greatly eased by placing the undulate screens 22, 24 out of phase with each other. However, it is possible to construct the cell skeleton 12 by stitching together in-phase screens or screens less than 180° out of phase, but the task in these last cases is more difficult, because stitching apparatus must work from one side of the cell skeleton 12 and through what will become the flow conduits 28, 30 rather than from both sides of the cell skeleton 12. No matter what material or what phase is used to create the cell skeleton 12 by stitching, the separator 20 must be punctured. Thus, for the separator 20 to be fluid-impermeable, a seal 46 must be provided around the stitches 44. The seal 46 may be comprised of simple silicon sealant or such sealing compositions as liquid NAFION™. A conductive (carbon-filled) epoxy sealant may be particularly useful if the separator 20 is non-conducting.

In Figure 8, another method of constructing cell skeletons 12 is illustrated in which non-metallic screens 22, 24 made of materials such as carbon cloth are bonded to a non-metallic separator stratum 20 such as a graphite sheet by means of conductive bonds 48 comprised of a bonding agent such as conductive epoxy or other carbon-filled (and therefore conductive) adhesive

substance. This approach has the advantage of avoiding puncturing of the separator stratum 20. The method has the further advantage that each undulate screen 22, 24 may be attached by working from only one side of the separator stratum 20 at a time as there is no need to have access to the other side of the separator stratum 20 as is the case in stitching. This method greatly facilitates the construction of cell skeletons 12 with undulate screens 22, 24 that are in phase with each other. The screens 22, 24 in Figure 8 are out-of-phase with each other, but this method may be used for screens 22, 24 in any phase relationship with each other. However, some conductive adhesives tend to have low conductivities that result in relatively high internal resistance within the resulting cell structure, so care must be taken to use an adhesive with as high a conductivity as possible.

When both the screens 22, 24 and the separator stratum 20 contain metallic components, then the cell skeleton 12 can be constructed using welding, brazing or soldering techniques. Spot welding requires the contact of an electrode structure with the cell skeleton components from both sides, and thus favours designs in which the two screens are 180° out of phase. Diffusion welding requires the entire cell skeleton 12 to be assembled and clamped into a jig, whereupon the clamped assembly can be placed in a high-temperature oven and subsequently welded.

If the screens 22, 24 are non-metallic, but the separator stratum 20 contains metallic components, the cell skeleton 12 can nevertheless be assembled using welding, brazing or soldering techniques by adding

auxiliary metal plates or the like. Figure 9 shows the use of a metallic separator stratum 20 with carbon screens 22, 24. In order to create the desired electronic and mechanical bond, thin plates 50 of metallic material are laid on top of the screens 22, 24 and are each welded, brazed or soldered through the screens 22, 24 to the separator stratum 20.

In simplified summary, the cell skeletons 12 and layered MEA structures 25 may be assembled together into the fuel cell stack 10 either (1) by inserting sheets of conventional MEA material 31 between the cell skeletons 12 and clamping the cell skeletons 12 together under pressure to conform the MEA material 31 to the undulations of the associated screens 22, 24, thereby forming the layered MEA structure 25A shown in Figure 2A or (2) by forming the MEA strata *in situ* between cell skeletons 12 to form the layered MEA structures 25B, 25C, 25D, and 25E shown in Figures 2B, 2C, 2D, and 2E.

A detailed description of these alternative methods of assembling fuel cell stack 10 follows.

The simplest method of assembling the fuel cell stack 10 is to place a discrete sheet of conventional MEA material 31 between each consecutive pair of cell skeletons 12 and clamp the cell skeletons 12 together, thereby forcing the MEA 31 to conform to the shape of the screens 22, 24, and forming the layered MEA structure 25A described briefly above in reference to Figure 2A. Conventional MEA material 31 is highly flexible and quite thin. It can be readily formed into waves of the desired wavelength and amplitude. The preferred method of fabrication is to pre-shape the MEA material 31 into a waved pattern before it is placed

between the cell skeletons 12. By rolling or by using curved stamping templates to shape only a small portion of the membrane material at any instant, the rest of the membrane material 31 may move so as to conform to the waved shape without stretching. The pre-shaped MEA material 31 thus roughly conforms to the waved pattern and so is easily inserted between two cell skeletons 12.

The foregoing method of assembly of MEA to cell skeleton may be implemented using standard fuel cell MEA fabrication techniques, but has the disadvantage that simple mechanical contact between the MEA 31 and the screens 22, 24 provides the needed conductive path between the electrocatalytic particles 27 and the screens 22, 24. Clamping force must be applied to reduce the contact resistance within the cell stack 10, but the clamping force need not be as large as that required in conventional PEM fuel cell stacks such as that illustrated in Figure 1 because the contact of the MEA 31 with the screens 22, 24 in the design described in reference to Figures 2 and 2A is spread over the entire surface of the MEA 31 rather than concentrated at the contact areas 45 as illustrated in Figure 1.

The following four methods of assembling the fuel cell stack 10 are preferred to the use of conventional MEA material and were described briefly above in reference to Figure 2B, 2C, 2D, and 2E. These methods will now be described in more detail.

In the method of assembling the fuel cell stack 10 that results in the layered MEA structure 25B discussed in reference to Figure 2B, electrocatalytic particles 27 are directly applied to a sheet of flexible proton

exchange membrane material 14 using screen printing, spraying, electrochemical deposition, or direct manual application. The catalyzed membrane 14 is pre-shaped into a waved pattern in the manner described above in relation to conventional MEA material 31. The pre-shaped membrane 14 is then placed between consecutive cell skeletons 12 and the layered MEA structure 25 is formed by hot pressing the cell skeletons 12 together with the membrane 14 therebetween. The screens 22, 24 then act as electrode layers in the assembled composite MEA stratum 25B. Since the hot pressing/bonding operation for all cells in the fuel cell stack can be done at one and the same time, the heat and pressure required to form layered MEA structure 25B in this manner result in a fuel cell stack 10 that is permanently integrally bonded together, thereby eliminating the need for clamping force to reduce contact resistance (although a modest amount of clamping force may still be needed for other purposes, such as boundary seals at gas entry and exit ports, etc. - this remark applies to alternative manufacturing methods described herein as well as to the Fig. 2B technique).

In the method of assembling the fuel cell stack 10 that results in the layered MEA structure 25C discussed above in reference to Figure 2C, the screens 22, 24 are coated with electrocatalyst 27 using a suitable vapour-deposition technique or the like. The membrane 14 is pre-shaped into a waved pattern in the manner described above in relation to conventional MEA material 31. The pre-shaped membrane 14 is then placed between consecutive cell skeletons 12 and the layered MEA structure 25 is formed by hot pressing the cell skeletons 12 together with the membrane 14 therebetween.

The porosity of the screens 22, 24 is important in this method of fabrication as the screens 22, 24 replace the porous electrode sheets of conventional MEA material, so it may be necessary, as illustrated in Figure 2E, to coat the screens 22, 24 with a porous conductive layer 47, before the electrocatalyst coating 27 is applied in order to reduce the macroscopic porosity and create a microscopically porous diffusion layer. For example, a porous conductive layer 47 of polyanelyne may be applied to stainless steel screens 22, 24. In general, it is desirable to maximize the surface area of the screens 22, 24. The screens 22, 24 are considered to be macroscopically porous, so that the effective surface area of the screens 22, 24 can be increased by filling the pores of the screens 22, 24 with a conductive material that is porous at the microscopic scale. Again, because all fuel cells are arranged in series in the stack and are assembled concurrently by the heat/pressure technique described, the heat and pressure required to form the layered MEA structures 25C and 25E in this manner result in a fuel cell stack 10 that is permanently integrally bonded together, thereby eliminating the need for clamping force to reduce contact resistance.

Since the present invention teaches methods of achieving electrically conductive paths for current collection that are not necessarily achieved by simple mechanical contact of conductive separators against planar MEA strata (by the application of clamping forces), a method of assembling the fuel cell stack 10 using alternative electrolyte materials that results in the layered MEA structure 25D discussed above in reference to Figure 2D is feasible. A semi-liquid or

gelled electrolyte 33 may be used between catalyzed screens 22, 24 to form a membrane 14. The gel-like electrolyte 33 fills the pores of the screens 22, 24 and thus forms the membrane 14 without the application of high temperatures and extreme pressures. In order to stabilize the gel 33 within this structure and to prevent the screens 22, 24 from short-circuiting, a large scale (coarse) mesh 35 is inserted between the screens 22, 24. The mesh 35 can be made of any inert and non-conductive material such as TEFLON™. The gel 33 then fills the openings in the mesh. A nominal clamping force is required to hold the stack 10 together.

Fuel cells in accordance with the present invention offer the advantages of reduced weight and cost, by virtue of a reduction, relative to conventional fuel cells, in materials used in the fuel cell fabrication and the opportunity to manufacture the fuel cell components in a continuous extrusion process. Fuel cells of varying size and power output can be manufactured by cutting the extrusion to the desired length, and affixing fluid manifolds (not shown) to the exposed axial ends of the fuel cell layers. A wide variety of manifolding strategies are available, due to the easy access to the ends of the reactant conduits.

Hydrogen may be used as a fuel gas in a fuel cell stack formed of fuel cell layers in accordance with the invention. In Figures 2, 3, 3A, 4, and 4A portions of exemplary fuel cell stacks 10 are shown as made up of fuel cell layers 32A and 32B. Stack 10 is connectable via a cathode terminal (not shown) and an anode terminal

(not shown) to an external load (not shown). Using as an example the fuel cell layer indicated by reference numeral 32A, each fuel cell layer 32 has a discrete MEA layer 25A and is associated with two of the reactant-gas impermeable separator layers 20A, 20B. MEA layer 25A has a porous anode electrode 18, a porous cathode electrode 16, an electrolytic membrane layer 14 disposed between the two electrodes 16, 18, an anode electro-catalyst layer (not shown) disposed between the electrolytic membrane layer 14 and the anode electrode 18, and a cathode electro-catalyst layer (not shown) disposed between the electrolytic membrane layer 14 and the cathode electrode 16. One side of one associated separator layer 20A in conjunction with the MEA layer 25A provides at least one flowpath of a flow field for hydrogen and one side of the other associated separator layer 20B in conjunction with the MEA layer 25A provides at least one flowpath of a flow field for a selected oxidant. The flowpaths are constituted over their greater length by parallel transversely spaced and longitudinally extending flow channels interconnected in the vicinity of their ends to form the flowpaths. Each MEA layer 25A, 25B is installed in the stack between the associated separator layers 20A, 20B, 20C so that the side of the separator layer that in conjunction with the MEA layer provides flow channels of a flow field for hydrogen faces and is in contact with the anode side of the MEA layer 25A, 25B, whilst the side of the separator layer providing flow channels of a flow field for oxidant faces and is in contact with the cathode side of the MEA layer 25A, 25B, so that the hydrogen flow channels are closed to form a conduit for supplying hydrogen to the MEA layer 25A, 25B and the oxidant flow channels are interconnected in the manner described

above to form a conduit for supplying oxidant to the MEA layer 25A, 25B. For example, in fuel cell layer indicated by reference numeral 32A, the oxidant flow channels are indicated by reference numeral 28 and the hydrogen flow channels by reference numeral 30. The fuel cells 32A, 32B are stacked in sequence and the anode electrode 18 of the fuel cell, say 32A, at one extremity of the stack electrically connected to the anode terminal, the cathode electrode 16 of the fuel cell 32B at the other extremity of the stack 10 electrically connected to the cathode terminal, and the anode electrode of each of the other fuel cells in the stack electrically connected to the cathode electrode of the next adjacent fuel cell. When the anode terminal and cathode terminal are electrically connected through an external load and for each fuel cell hydrogen is supplied to the hydrogen conduit and oxygen is supplied to the oxidant conduit, then in each fuel cell hydrogen moves from the hydrogen flow field through the anode electrode and is ionized at the anode electro-catalyst layer to yield electrons and hydrogen ions, the hydrogen ions migrate through the electrolytic membrane layer 14 to react with oxygen that has moved from the oxidant flow field through the cathode electrode 16 to the cathode electro-catalyst layer and with electrons that have moved from the anode electrode 18 electrically connected to the cathode electrode, thereby to form water as a reaction product, and a useful current of electrons is thereby produced through the load.

While particular elements, embodiments and applications of the present invention have been shown and described, it will be understood, of course, that the invention is not limited thereto, since

modifications may be made by those skilled in the applicable technologies, particularly in light of the foregoing description. The appended claims include within their ambit such modifications and variants of the exemplary embodiments of the invention described herein as would be apparent to those skilled in the applicable technologies.

What is claimed is:

1. For use in a PEM-type fuel cell stack comprising a series of stacked repeating fuel cell subassemblies, a fuel cell stack subassembly comprising:

a layered MEA structure having a uniform thickness and extending generally perpendicular to the stack dimension; and

a first reactant gas-impermeable separator stratum extending generally in dimensions perpendicular to the stack dimension, lying adjacent the layered MEA structure on one side thereof, and in non-continuous physical and electrical contact therewith over an array of contact areas so as to form at least one discrete conduit between the layered MEA structure and the first separator stratum for flow of a first reactant gas therethrough,

the array of contact areas between the layered MEA structure and the first separator stratum confined to a single plane,

the layered MEA structure comprising a reactant gas-impermeable ion-exchange membrane, sandwiched between a pair of reactant gas-permeable electrically conductive current collectors, having a discrete layer of electro-catalyst particles between the membrane and each current collector, and

the first separator stratum providing at least one electrically conductive path from the current collector in contact with first separator stratum through the first separator stratum to the side thereof opposite the side in contact with the current collector.

2. A subassembly as defined in claim 1, wherein the current collector of the layered MEA structure that is in contact with the first separator stratum is attached to the first separator stratum.

3. A subassembly as defined in either claim 1 or 2, wherein the first separator stratum is an uninterrupted layer of uniform thickness.

4. A subassembly as defined in any of claims 1 - 3, in combination with a second reactant gas-impermeable separator stratum extending generally in dimensions perpendicular to the stack dimension, lying adjacent the layered MEA structure on the other side thereof, and in non-continuous physical and electrical contact therewith so as to form at least one discrete conduit between the layered MEA structure and the second separator stratum for flow of a second reactant gas therethrough,

the second separator stratum providing at least one electrically conductive path from the current collector in contact with second separator stratum through the second separator stratum to the side thereof opposite the side in contact with the current collector.

5. A combination as defined in claim 4, wherein the current collector of the layered MEA structure that is in contact with the second separator stratum is attached to the second separator stratum.

6. A combination as defined in claim 4 or 5, wherein the second separator stratum is an uninterrupted layer of uniform thickness

7. The combination as defined in any of claims 4 - 6 installed in the fuel cell stack comprising a plurality of stacked said subassemblies aligned in stack direction, wherein the first separator stratum is integral with the second separator stratum of the next fuel cell subassembly in sequence and each electrically conductive path of first separator stratum is electrically connected with at least one electrically conductive path of the second separator stratum of the next fuel cell subassembly

8. The combination as defined in claim 7, wherein the portion of the interior surface area of any one reactant conduit constituted by the surface of the associated layered MEA structure is at least as large as the portion constituted by the surface of the associated separator stratum.

9. A subassembly as defined in any of claims 1 - 3, wherein the layered MEA structure is transversely undulate and the first separator stratum is in periodic axially extending physical and electrical contact with the apices of the undulations of the layered MEA structure lying next to the first separator stratum, the spaces between the first separator stratum and the layered MEA structure constituting axially extending conduits for flow of the first reactant gas therethrough.

10. A subassembly as defined in claim 9, in combination with a second reactant gas-impermeable separator stratum extending generally in dimensions perpendicular to the stack dimension, lying adjacent the layered MEA structure on the other side thereof, and in non-continuous physical and electrical contact therewith so as to form at least one discrete conduit between the layered MEA structure and the second separator stratum for flow of a second reactant gas therethrough,

the second separator stratum providing at least one electrically conductive path from the current collector in contact with second separator stratum through the second separator stratum to the side thereof opposite the side in contact with the current collector.

11. A combination as defined in claim 10, wherein the current collector of the layered MEA structure that is in contact with the second separator stratum is attached to the second separator stratum.

12. A combination as defined in claim 10 or 11, wherein the second separator

stratum is an uninterrupted layer of uniform thickness.

13. A combination as defined in any of claims 10 - 12, wherein the second separator stratum is in periodic axially extending physical and electrical contact with the apices of the undulations of the layered MEA structure lying next to the second separator stratum, the spaces between the second separator stratum and the layered MEA structure constituting axially extending conduits for flow of the second reactant gas therethrough

14. A combination as defined in claim 13, wherein the separator strata are transversely undulate.

15. A combination as defined in claim 14, wherein the undulations of the separator strata are in phase with the undulations of the layered MEA structure.

16. A combination as defined in claim 15, wherein the amplitude of the undulations of the layered MEA structures is greater than the amplitude of the undulations of the separator strata.

17. A combination as defined in claim 13, wherein the total axial cross-sectional area of the reactant gas conduits on one side of the layered MEA structure is greater than the total axial cross-sectional area of the reactant gas conduits other side of the layered MEA structure.

18. The combination as defined in any of claims 10 - 17 installed in the fuel cell stack comprising a plurality of stacked said subassemblies aligned in stack direction, wherein the first separator stratum is integral with the second separator stratum of the next fuel cell subassembly in sequence and each electrically conductive path of first separator stratum is electrically connected with at least one electrically conductive path of the second separator stratum of the next fuel cell subassembly.

19. The combination as defined in claim 18, wherein the waveform of the undulations of the layered MEA structures on either side of any one separator stratum are congruent.

20. The combination as defined in claim 19, wherein the waveform of the undulations of the layered MEA structures on either side of any one separator stratum are 180 degrees out of phase.

21. The combination as defined in claim 19 or claim 20, wherein the waveform of the undulations of the layered MEA structures are generally of sinusoidal configuration.

22. The combination as defined in claim 19 or claim 20, wherein the waveform of the undulations of the layered MEA structures are generally of triangular-wave configuration.

23. The combination as defined in any of claims 7 - 8 and 18 - 22, wherein any one layered MEA structure in the fuel cell stack additionally comprises two electrically conductive porous layers each disposed on a mutually opposed side of the membrane of the layered MEA structure between the membrane and the adjacent current collector of the layered MEA structure, and wherein the layered MEA structure is held in aligned position and under pressure in the stacking dimension by clamping pressure applied to the ends of the fuel cell stack.

24. The combination as defined in any of claims 7 - 8 and 18 - 22, wherein any one layered MEA structure in the fuel cell stack comprises a electro-catalyst coated ion-exchange membrane bonded between the associated pair of current collectors.

25. The combination as defined in any of claims 7 - 8 and 18 - 22, wherein any

one layered MEA structure in the fuel cell stack comprises a membrane bonded between the associated pair of current collectors, the side of each current collector bonded to the membrane is coated with electro-catalyst particles.

26. The combination as defined in any of claims 7 - 8 and 18 - 22, wherein any one layered MEA structure in the fuel cell stack comprises a gel membrane disposed between between the associated pair of current collectors, the side of each current collector in contact with the membrane coated with the electro-catalyst particles.

27. The combination as defined in claim 26, wherein the gel fills the pores of the current collectors.

28. The combination as defined in claim 27, additionally comprising a coarse non-conductive mesh disposed between the pair of current collectors of the layered MEA structure so that the gel is disposed in the interstices of the mesh.

29. The combination as defined in any of claims 7 - 8 and 18 - 22, wherein any one layered MEA structure in the fuel cell stack comprises a membrane bonded between a pair of reactant gas-permeable electrically conductive current collectors, the side of each current collector bonded to the membrane coated with a porous conductive layer under a coating of electro-catalyst particles.

30. The combination as defined in any of claims 4 - 8 and 10 - 22, wherein the current collectors are made of expanded metal mesh.

31. The combination as defined in claim 30, wherein any one of the separator strata is a printed circuit board comprised of an electrically insulating substrate overlaid on each surface by a selected pattern of electrically conductive traces, each trace on one side of the substrate is electrically connected to the traces on the opposite side of the substrate by a conductive path including at least one via, and at

least a portion of the pattern of traces on each side is in electrical contact with the current collector of the adjacent layered MEA structure.

32. The combination as defined in claim 31, wherein the current collectors associated with any one separator stratum are soldered to the traces of the separator stratum.

33. The combination as defined in claim 30, wherein each separator stratum is a thin electrically conductive plate.

34. The combination as defined in claim 33, wherein the current collectors associated with any one separator stratum are soldered to the separator stratum.

35. The combination as defined in claim 33, wherein the current collectors associated with any one separator stratum are welded to the separator stratum.

36. The combination as defined in claim 33, wherein the current collectors associated with any one separator stratum are brazed to the separator stratum.

37. The combination as defined in any of claims 4 - 8 and 10 - 22, wherein each separator stratum is a thin electrically conductive plate.

38. The combination as defined in claim 37, wherein the current collectors are made of carbon cloth.

39. The combination as defined in claim 38, wherein the current collectors associated with any one separator stratum are stitched to the separator stratum.

40. The combination as defined in claim 38, wherein each one of the current collectors associated with any one separator stratum is disposed between the

separator stratum and a discrete thin metal plate welded through the current collector to the separator stratum.

41. The combination as defined in claim 38, wherein each one of the current collectors associated with any one separator stratum is disposed between the separator stratum and a discrete thin metal plate brazed through the current collector to the separator stratum.

42. The combination as defined in claim 38, wherein each one of the current collectors associated with any one separator stratum is disposed between the separator stratum and a discrete thin metal plate soldered through the current collector to the separator stratum.

43. A fuel cell stack comprising

- (i) a stack of contiguously stacked pairs of contiguous layers, each said pair comprising a separator stratum and a contiguous membrane electrode assembly (MEA) layer, such that in the stack, substantially identical separator strata alternate with contiguous substantially identical MEA strata;
- (ii) means within the stack for providing electrical contact between successive ones of said MEA strata; and
- (iii) means to maintain the layers in alignment;

said layers being configured to form therebetween a plurality of stacked conduits extending generally parallel to one another in the flow dimension;

each said layer having extension in the transverse dimension and having extension

in the flow dimension and being substantially invariant in the flow dimension;

at least one of the layers in each interior pair of said pairs being an undulate layer, said undulate layer having limited extension in the stack dimension and extending transversely from one transverse boundary thereof to the other transverse boundary thereof in a transverse sequence of undulations, the peaks of which undulations are each in contact with an associated aligned portion of the other layer in the pair over a contact area having substantial continuous extension in the flow dimension and limited extension in the transverse dimension, and the troughs of which undulations are each in contact with an associated aligned portion of the alternate layer in the next adjacent pair over a contact area having substantial continuous extension in the flow dimension and limited extension in the transverse dimension, thereby to form a pair of arrays of contact areas, said contact area arrays being spaced from one another in the stack dimension, each said contact area array comprised of transversely spaced contact areas extending generally parallel to one another in the flow dimension and in a discrete plane, said layers and said contact areas forming said plurality of stacked conduits, each said conduit being bounded by those portions of adjacent ones of said layers lying between successive contact areas in the same contact array.

44. The fuel cell stack of claim 43, wherein the means within the stack for providing electrical contact between successive ones of said MEA strata includes electrically conductive material located in the said contact areas.

45. For use in a fuel cell stack, an undulate layer when installed in the stack having limited extension in the stack dimension and extending transversely from one transverse boundary thereof to the other transverse boundary thereof in a transverse sequence of undulations the peaks of which undulations, when the undulate layer is installed in the stack, are each in contact with an associated aligned portion of an adjacent stack layer over a contact area having substantial continuous extension in

the flow dimension and limited extension in the transverse dimension, and the troughs of which undulations, when the undulate layer is installed in the stack, are each in contact with an associated aligned portion of another adjacent stack layer over a contact area having substantial continuous extension in the flow dimension and limited extension in the transverse dimension, thereby to form a pair of arrays of contact areas, said contact area arrays being spaced from one another in the stack dimension, each said contact area array comprised of transversely spaced contact areas extending generally parallel to one another in the flow dimension and in a discrete plane, said layers and said contact areas forming said plurality of stacked conduits, each said conduit being bounded by those portions of adjacent ones of said layers lying between successive contact areas in the same contact array.

46. An undulate layer as defined in claim 45, wherein the undulate layer serves as a separator stratum when installed in the fuel cell stack.

47. An undulate layer as defined in claim 45, wherein the undulate layer is electrically conductive.

48. An undulate layer as defined in claim 45, the undulate layer further comprising a membrane layer sandwiched between two electrode layers, wherein the undulate layer is an MEA stratum.

49. The invention of any of claims 45 - 48, wherein each said undulate layer is sufficiently rigid so as to be dimensionally stable both *per se* and when installed in the fuel cell stack.

50. An undulate layer as defined in claim 45, wherein the undulate layer is continuously curved.

51. An undulate layer as defined in claim 46, wherein the undulate layer is an

uninterrupted layer of uniform thickness.

52. A combination as defined in any of claims 4 -8, wherein, in a coordinate system fixed to the layered MEA structure, in which coordinate system the position of a point is defined by stack, transverse, and axial dimension coordinates, the stack dimension coordinates of points on a selected side of the layered MEA structure is a periodic function of the transverse dimension coordinate.

53. A combination as defined in claim 52, wherein stack dimension coordinate of points on the selected side of the layered MEA structure is independent of the axial dimension coordinate.

54. A combination as defined in claim 53, wherein the layered MEA structure is attached on one side to one of the separator strata lying adjacent to it at at least two of the maxima of the periodic function describing that side of the layered MEA structure and to the other of the separator strata lying adjacent to it at at least two of the minima of the periodic function describing the other side of the layered MEA structure, thereby forming at least one reactant gas conduit on each side of the layered MEA structure extending through the fuel cell stack in the axial dimension.

55. A combination as defined in claim 54, wherein the layered MEA structure is attached on one side to one of the separator strata lying adjacent to it at all of the maxima of the periodic function describing that side of the layered MEA structure and to the other one of the separator strata lying adjacent to it at all of the minima of the periodic function describing the other side of the layered MEA structure, thereby forming a plurality of parallel reactant gas conduits on each side of the layered MEA structure extending in the axial dimension through the fuel cell stack in the axial dimension.

56. A combination as defined in claim 55, wherein the functions providing the

stack dimension coordinates of points on the surfaces of the layered MEA structures on opposite sides of each discrete separator stratum are 180 degrees out of phase with each other.

57. A combination as defined in claim 55, wherein the functions providing the stack dimension coordinates of points on the surfaces of the layered MEA structures on opposite sides of each discrete separator stratum are in phase with each other.

58. A combination as defined in claim 53 or claim 54, wherein stack dimension coordinate of points on each side of any one of the separator strata is a discrete periodic function of the transverse dimension coordinate.

59. A combination as defined in claim 58, wherein the function providing the stack dimension coordinates of points on any one side of any one of the layered MEA structures and the function providing the stack dimension coordinates of points on the side of the separator stratum lying adjacent the layered MEA structure are in phase and differ in amplitude, the function describing the surfaces of the layered MEA structure having a greater amplitude than the function describing the side of the separator stratum.

60. The use of hydrogen as a fuel gas in fuel cells in a fuel cell stack connectable via an anode terminal and a cathode terminal to an external load, each said fuel cell having:

- (i) a layered MEA structure having a porous anode electrode, a porous cathode electrode, an electrolytic membrane layer disposed between the two electrodes, an anode electro-catalyst layer disposed between the electrolytic membrane layer and the anode electrode, and a cathode electro-catalyst layer disposed between the electrolytic membrane layer and the cathode electrode; and

- (ii) two discrete associated reactant-gas impermeable separator layers, one side of one layer in conjunction with the layered MEA structure providing at least one flowpath of a flow field for hydrogen and one side of the other layer in conjunction with the layered MEA structure providing at least one flowpath of a flow field for a selected oxidant, the flowpaths are constituted over their greater length by parallel transversely spaced and longitudinally extending flow channels interconnected in the vicinity of their ends to form the flowpaths;

the layered MEA structure being installed in the stack between the associated separator layers so that the side of the separator layer that in conjunction with the layered MEA structure provides flow channels of a flow field for hydrogen faces and is in contact with the anode side of the layered MEA structure, whilst the side of the separator layer providing flow channels of a flow field for oxidant faces and is in contact with the cathode side of the layered MEA structure, so that the hydrogen flow channels are closed to form a conduit for supplying hydrogen to the layered MEA structure and the oxidant flow channels are closed to form a conduit for supplying oxidant to the layered MEA structure; and

the fuel cells being stacked in sequence, the anode electrode of the fuel cell at one extremity of the stack being electrically connected to the anode terminal, the cathode electrode of the fuel cell at the other extremity of the stack being electrically connected to the cathode terminal, and the anode electrode of each of the other fuel cells in the stack being electrically connected to the cathode electrode of the next adjacent fuel cell,

so that when the anode terminal and cathode terminal are electrically connected through an external load and for each fuel cell hydrogen is

supplied to the hydrogen conduit and oxygen is supplied to the oxidant conduit, then in each fuel cell hydrogen moves from the hydrogen flow field through the anode electrode and is ionized at the anode electro-catalyst layer to yield electrons and hydrogen ions, the hydrogen ions migrate through the electrolytic membrane layer to react with oxygen that has moved from the oxidant flow field through the cathode to the cathode electro-catalyst layer and with electrons that have moved from the anode electrode electrically connected to the cathode electrode, thereby to form water as a reaction product, and a useful current of electrons is thereby produced through the load

each fuel cell characterized in that

the layered MEA structure has a uniform thickness and extends generally in dimensions perpendicular to the stack dimension; and

a first one of the separator layers extends generally in dimensions perpendicular to the stack dimension, lying adjacent the layered MEA structure on one side thereof, and in non-continuous physical and electrical contact therewith over an array of contact areas so as to form at least one discrete conduit between the layered MEA structure and the first separator layer for flow of a first reactant gas therethrough, and

the array of contact areas between the layered MEA structure and the first separator layer is confined to a single plane.

61. The use of hydrogen as defined in claim 60, wherein the current collector of the layered MEA structure that is in contact with the first separator stratum is attached to the first separator stratum.

62. The use of hydrogen as defined in either claim 60 or 61, wherein the first separator stratum is an uninterrupted layer of uniform thickness.

63. The use of hydrogen as defined in any of claims 60 - 62, in combination with a second reactant gas-impermeable separator stratum extending generally in dimensions perpendicular to the stack dimension, lying adjacent the layered MEA structure on the other side thereof, and in non-continuous physical and electrical contact therewith so as to form at least one discrete conduit between the layered MEA structure and the second separator stratum for flow of a second reactant gas therethrough,

the second separator stratum providing at least one electrically conductive path from the current collector in contact with second separator stratum through the second separator stratum to the side thereof opposite the side in contact with the current collector.

64. The use of hydrogen as defined in claim 63, wherein the current collector of the layered MEA structure that is in contact with the second separator stratum is attached to the second separator stratum.

65. The use of hydrogen as defined in claim 63 or 64, wherein the second separator stratum is an uninterrupted layer of uniform thickness.

66. The use of hydrogen as defined in any of claims 63 - 65 installed in the fuel cell stack comprising a plurality of stacked said fuel cells aligned in stack direction, wherein the first separator stratum is integral with the second separator stratum of the next fuel cell subassembly in sequence and each electrically conductive path of first separator stratum is electrically connected with at least one electrically conductive path of the second separator stratum of the next fuel cell.

67. The use of hydrogen as defined in claim 66, wherein the portion of the interior surface area of any one reactant conduit constituted by the surface of the associated layered MEA structure is at least as large as the portion constituted by the surface of the associated separator stratum.

68. The use of hydrogen as defined in any of claims 65 - 67, wherein the layered MEA structure is transversely undulate and the first separator stratum is in periodic axially extending physical and electrical contact with the apices of the undulations of the layered MEA structure lying next to the first separator stratum, the spaces between the first separator stratum and the layered MEA structure constituting axially extending conduits for flow of the first reactant gas therethrough.

69. The use of hydrogen as defined in claim 68, in combination with a second reactant gas-impermeable separator stratum extending generally in dimensions perpendicular to the stack dimension, lying adjacent the layered MEA structure on the other side thereof, and in non-continuous physical and electrical contact therewith so as to form at least one discrete conduit between the layered MEA structure and the second separator stratum for flow of a second reactant gas therethrough,

the second separator stratum providing at least one electrically conductive path from the current collector in contact with second separator stratum through the second separator stratum to the side thereof opposite the side in contact with the current collector.

70. The use of hydrogen as defined in claim 69, wherein the current collector of the layered MEA structure that is in contact with the second separator stratum is attached to the second separator stratum.

71. The use of hydrogen as defined in claim 69 or 70, wherein the second

separator stratum is an uninterrupted layer of uniform thickness.

72. The use of hydrogen as defined in any of claims 69 - 71, wherein the second separator stratum is in periodic axially extending physical and electrical contact with the apices of the undulations of the layered MEA structure lying next to the second separator stratum, the spaces between the second separator stratum and the layered MEA structure constituting axially extending conduits for flow of the second reactant gas therethrough

73. The use of hydrogen as defined in claim 72, wherein the separator strata are transversely undulate.

74. The use of hydrogen as defined in claim 73, wherein the undulations of the separator strata are in phase with the undulations of the layered MEA structure.

75. The use of hydrogen as defined in claim 74, wherein the amplitude of the undulations of the layered MEA structures is greater than the amplitude of the undulations of the separator strata.

76. The use of hydrogen as defined in claim 72, wherein the total axial cross-sectional area of the reactant gas conduits on one side of the layered MEA structure is greater than the total axial cross-sectional area of the reactant gas conduits other side of the layered MEA structure.

77. The use of hydrogen as defined in any of claims 69 - 76 installed in the fuel cell stack comprising a plurality of stacked said subassemblies aligned in stack direction, wherein the first separator stratum is integral with the second separator stratum of the next fuel cell subassembly in sequence and each electrically conductive path of first separator stratum is electrically connected with at least one electrically conductive path of the second separator stratum of the next fuel cell

subassembly.

78. The use of hydrogen as defined in claim 77, wherein the waveform of the undulations of the layered MEA structures on either side of any one separator stratum are congruent.

79. The use of hydrogen as defined in claim 78, wherein the waveform of the undulations of the layered MEA structures on either side of any one separator stratum are 180 degrees out of phase.

80. The use of hydrogen as defined in claim 78 or claim 79, wherein the waveform of the undulations of the layered MEA structures are generally of sinusoidal configuration.

81. The use of hydrogen as defined in claim 78 or claim 79, wherein the waveform of the undulations of the layered MEA structures are generally of triangular-wave configuration.

82. The use of hydrogen as defined in any of claims 66 - 67 and 77 - 81, wherein any one layered MEA structure in the fuel cell stack additionally comprises two electrically conductive porous layers each disposed on a mutually opposed side of the membrane of the layered MEA structure between the membrane and the adjacent current collector of the layered MEA structure, and wherein the layered MEA structure is held in aligned position and under pressure in the stacking dimension by clamping pressure applied to the ends of the fuel cell stack.

83. The use of hydrogen as defined in any of claims 66 - 67 and 77 - 81, wherein any one layered MEA structure in the fuel cell stack comprises a electro-catalyst coated ion-exchange membrane bonded between the associated pair of current collectors.

84. The use of hydrogen as defined in any of claims 66 - 67 and 77 - 81, wherein any one layered MEA structure in the fuel cell stack comprises a membrane bonded between the associated pair of current collectors, the side of each current collector bonded to the membrane is coated with electro-catalyst particles.

85. The use of hydrogen as defined in any of claims 66 - 67 and 77 - 81, wherein any one layered MEA structure in the fuel cell stack comprises a gel membrane disposed between between the associated pair of current collectors, the side of each current collector in contact with the membrane coated with the electro-catalyst particles.

86. The use of hydrogen as defined in claim 85, wherein the gel fills the pores of the current collectors.

87. The use of hydrogen as defined in claim 86, additionally comprising a coarse non-conductive mesh disposed between the pair of current collectors of the layered MEA structure so that the gel is disposed in the interstices of the mesh.

88. The use of hydrogen as defined in any of claims 66 - 67 and 77 - 81, wherein any one layered MEA structure in the fuel cell stack comprises a membrane bonded between a pair of reactant gas-permeable electrically conductive current collectors, the side of each current collector bonded to the membrane coated with a porous conductive layer under a coating of electro-catalyst particles.

89. The use of hydrogen as defined in any of claims 63 - 67 and 69 - 81, wherein the current collectors are made of expanded metal mesh.

90. The use of hydrogen as defined in claim 89, wherein any one of the separator strata is a printed circuit board comprised of an electrically insulating substrate overlaid on each surface by a selected pattern of electrically conductive traces, each

trace on one side of the substrate is electrically connected to the traces on the opposite side of the substrate by a conductive path including at least one via, and at least a portion of the pattern of traces on each side is in electrical contact with the current collector of the adjacent layered MEA structure.

91. The use of hydrogen as defined in claim 90, wherein the current collectors associated with any one separator stratum are soldered to the traces of the separator stratum.

92. The use of hydrogen as defined in claim 89, wherein each separator stratum is a thin electrically conductive plate.

93. The use of hydrogen as defined in claim 92, wherein the current collectors associated with any one separator stratum are soldered to the separator stratum.

94. The use of hydrogen as defined in claim 92, wherein the current collectors associated with any one separator stratum are welded to the separator stratum.

95. The use of hydrogen as defined in claim 92, wherein the current collectors associated with any one separator stratum are brazed to the separator stratum.

96. The use of hydrogen as defined in any of claims 63 - 67 and 69 - 81, wherein each separator stratum is a thin electrically conductive plate.

97. The use of hydrogen as defined in claim 96, wherein the current collectors are made of carbon cloth.

98. The use of hydrogen as defined in claim 97, wherein the current collectors associated with any one separator stratum are stitched to the separator stratum.

99. The use of hydrogen as defined in claim 97, wherein each one of the current collectors associated with any one separator stratum is disposed between the separator stratum and a discrete thin metal plate welded through the current collector to the separator stratum.

100. The use of hydrogen as defined in claim 97, wherein each one of the current collectors associated with any one separator stratum is disposed between the separator stratum and a discrete thin metal plate brazed through the current collector to the separator stratum.

101. The use of hydrogen as defined in claim 97, wherein each one of the current collectors associated with any one separator stratum is disposed between the separator stratum and a discrete thin metal plate soldered through the current collector to the separator stratum.

102. A PEM-type fuel cell stack comprising a series of alternating MEA and separator layers stacked together in mechanical and electrical contact and providing conduits for flow of reactant gases and coolants from external sources to electrochemically active regions of the MEA layers, each MEA layer including an electrolytic membrane sandwiched between anode and cathode layers; characterized in that each said MEA layer is of undulate configuration providing generally parallel reactant gas flow channels extending longitudinally in the flow dimension.

103. A PEM-type fuel cell stack as defined in claim 102, wherein the undulations of the MEA layer have a regular period.

104. A PEM-type fuel cell stack as defined in claim 103, wherein the separator layers are non-planar layers comprised of periodically repeating constituents having a period identical to that of the MEA layer.

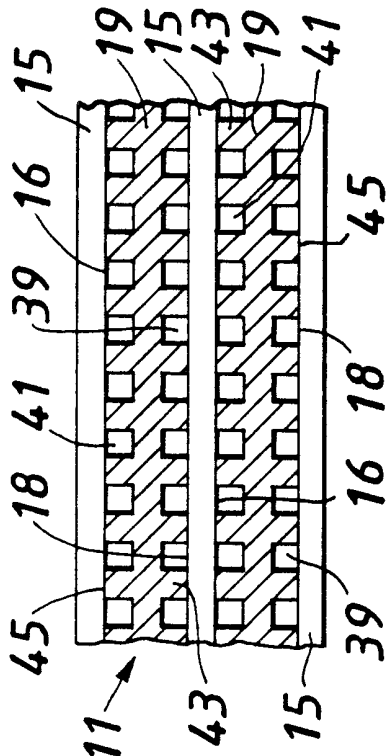

FIG. 1.
(Prior Art)

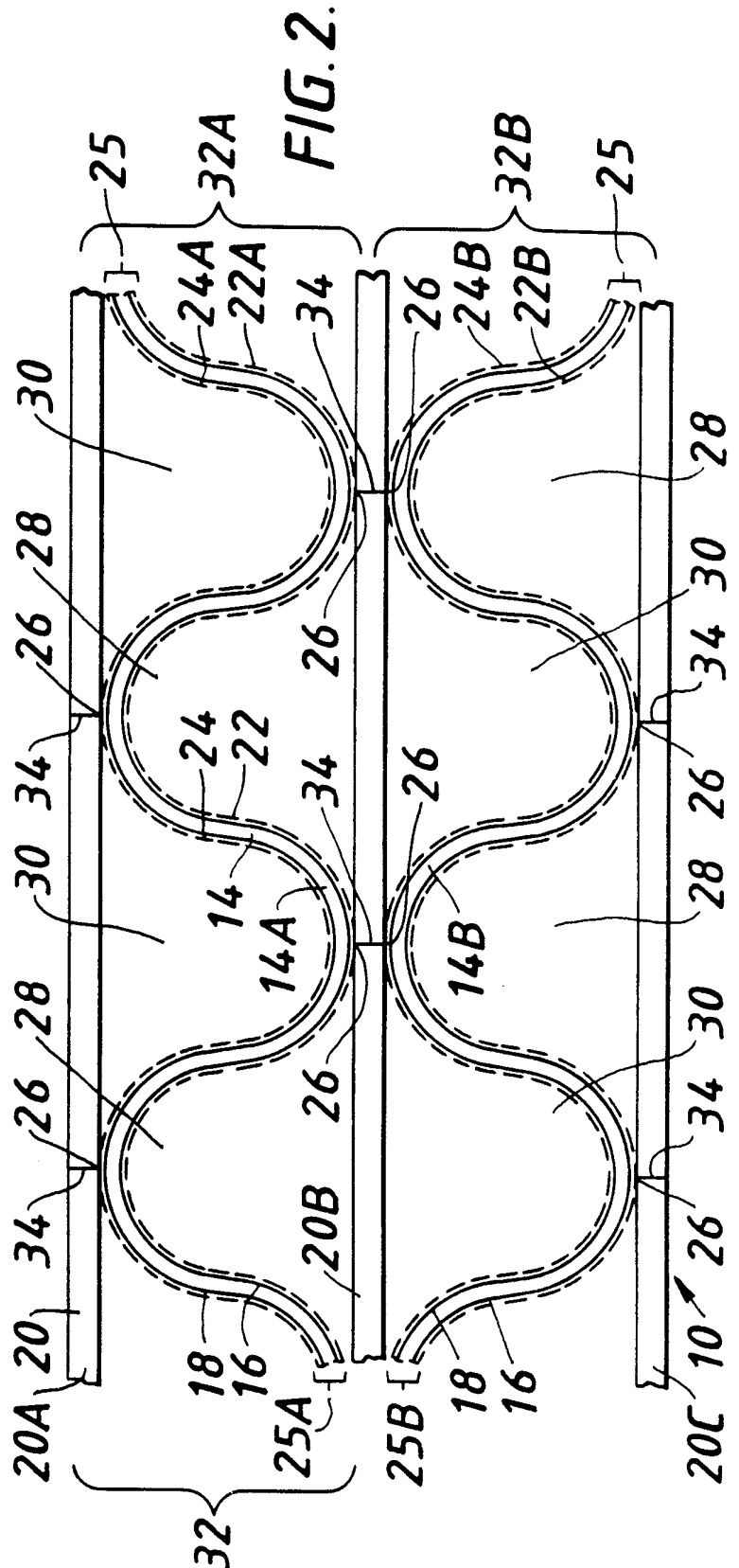

FIG. 2.

FIG. 2A.

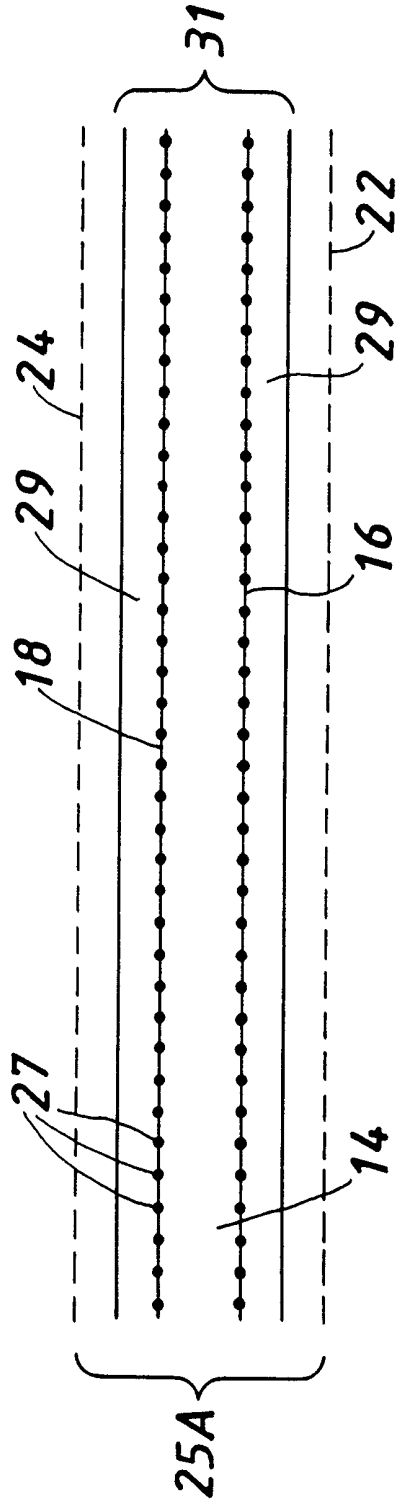

FIG. 2B.

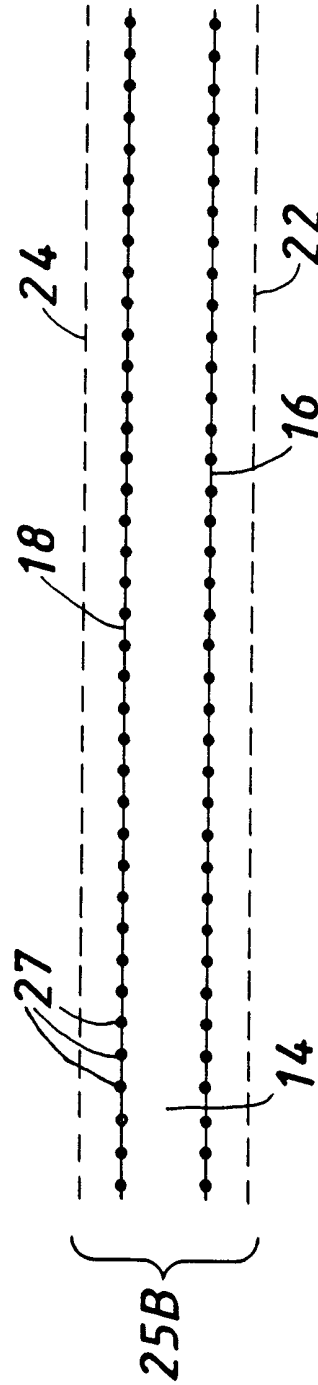

FIG. 2C.

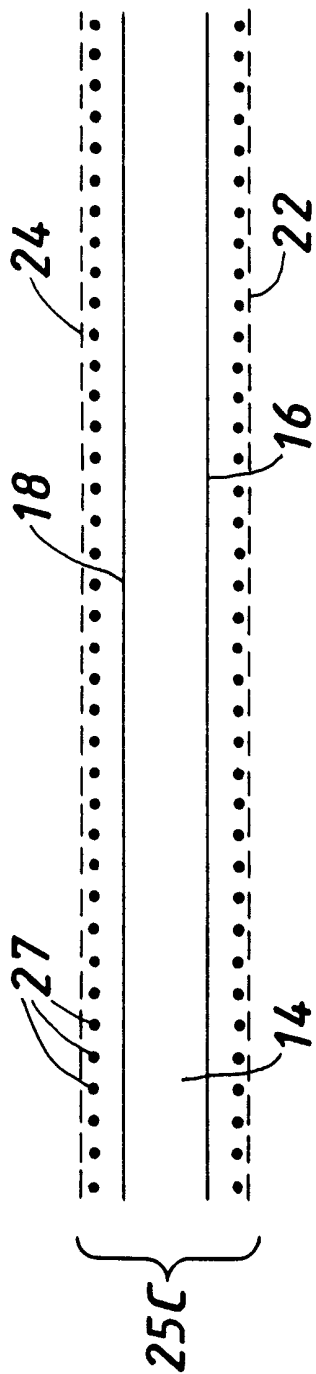
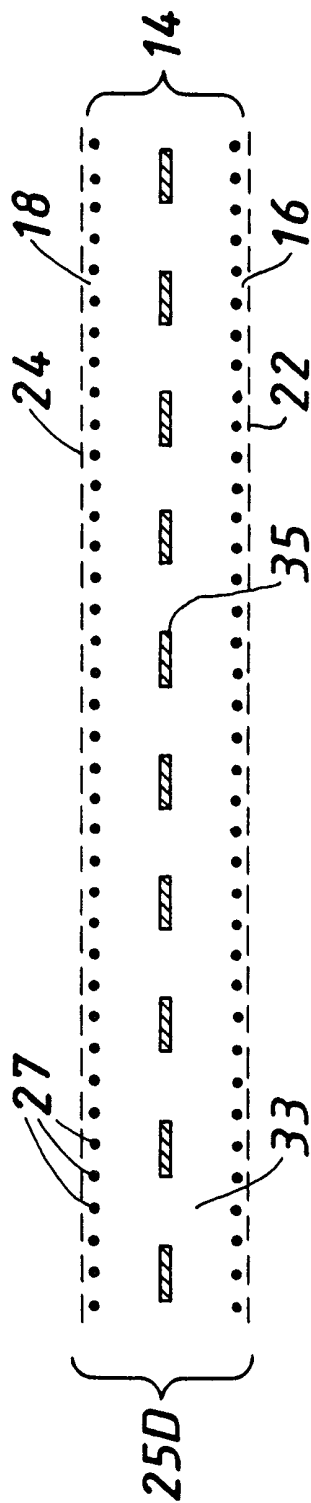
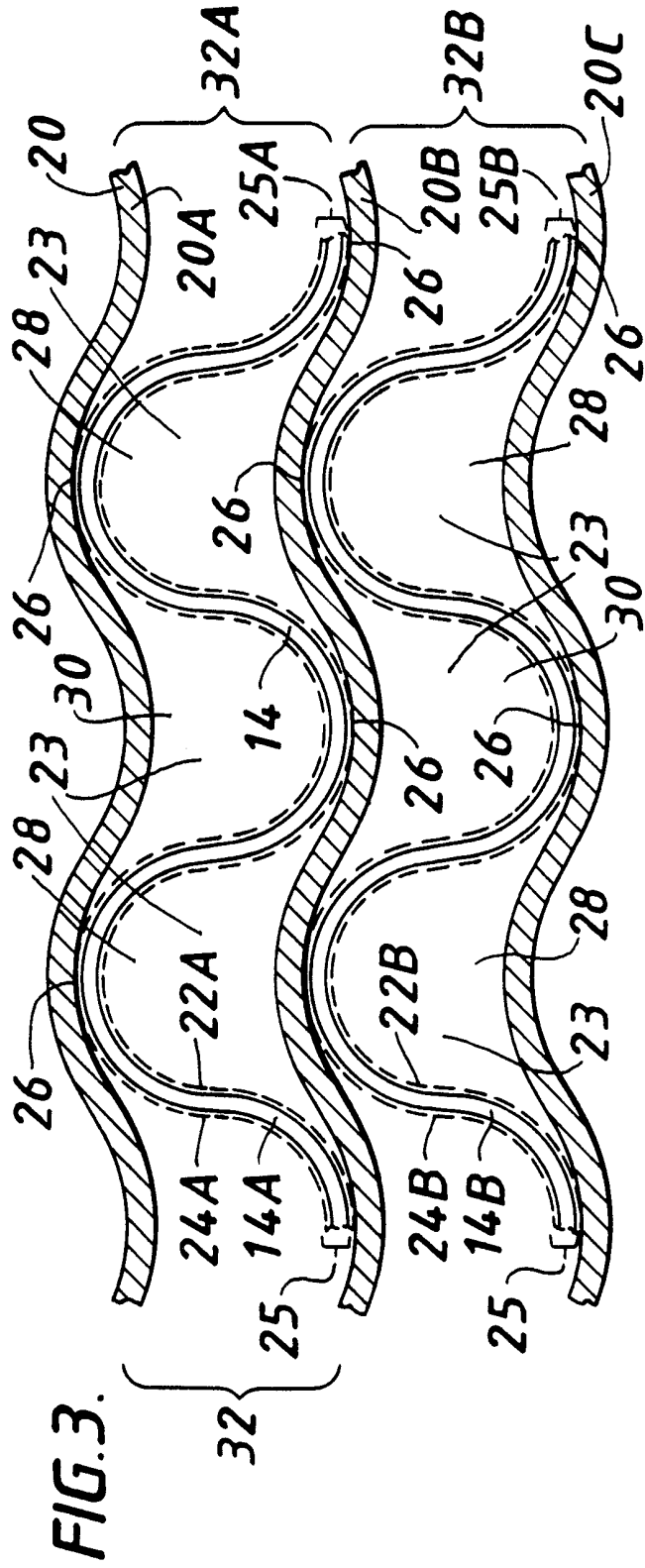
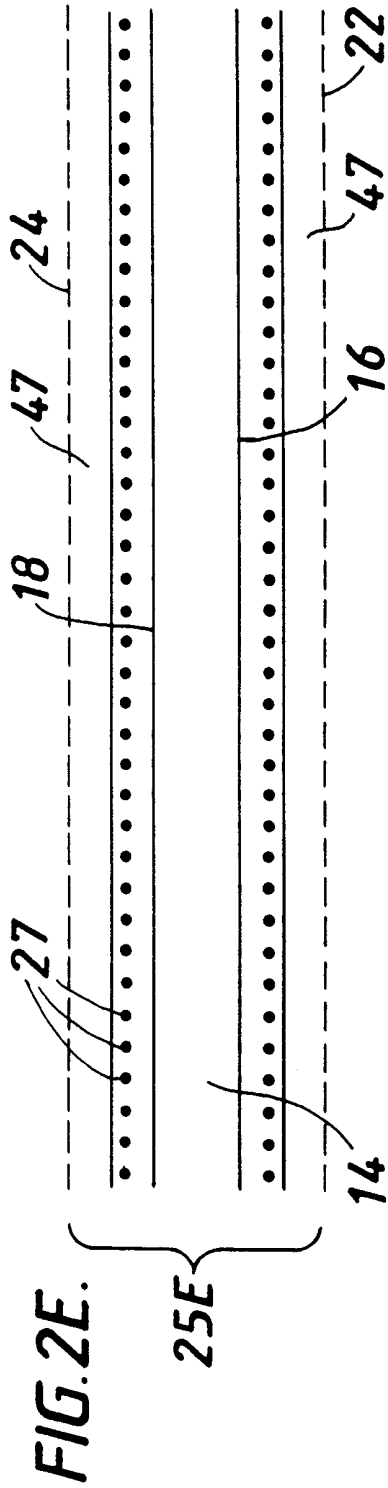
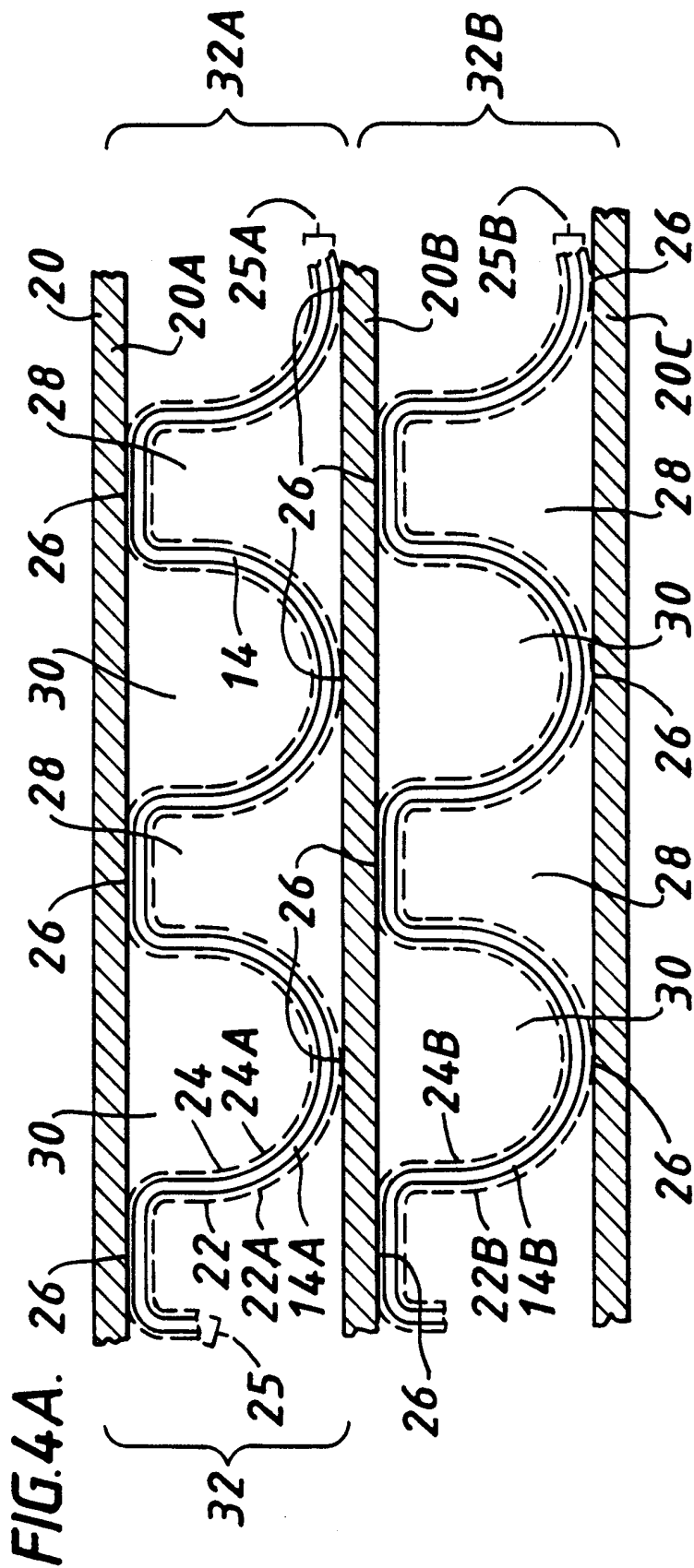

FIG. 2D.







8/9

FIG. 6.

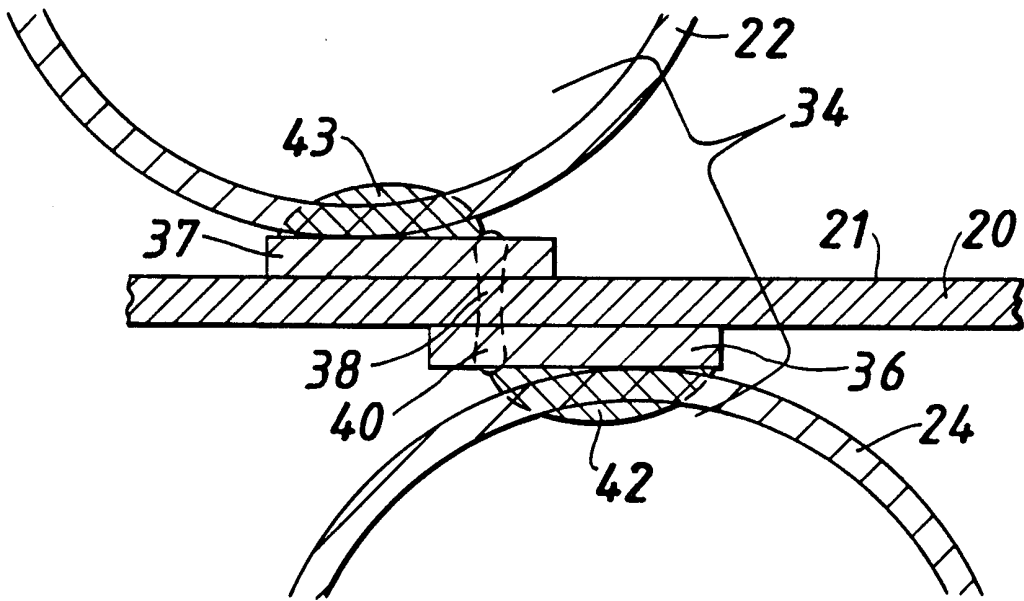
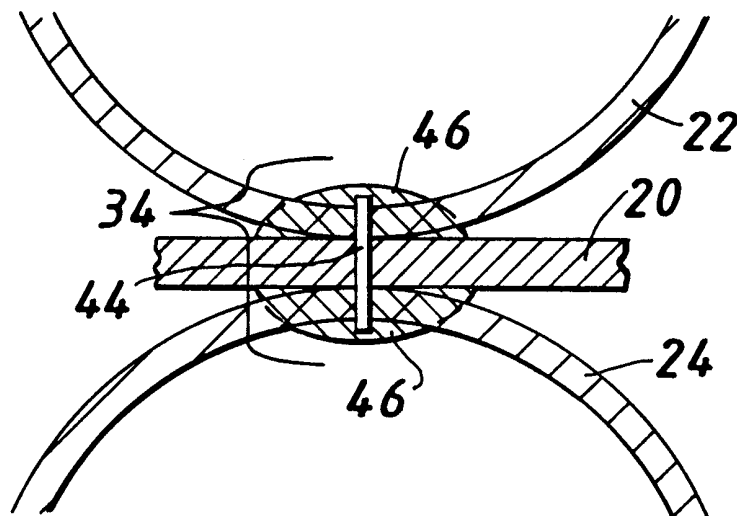

FIG. 7.



9/9

FIG. 8.

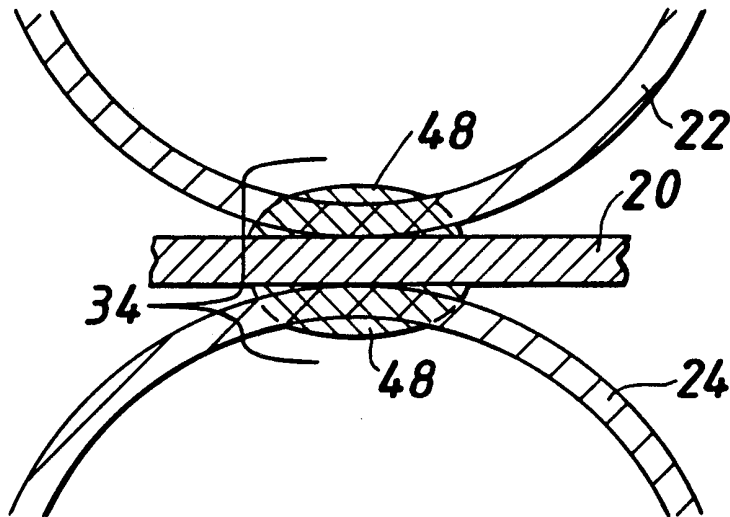

FIG. 9.

