

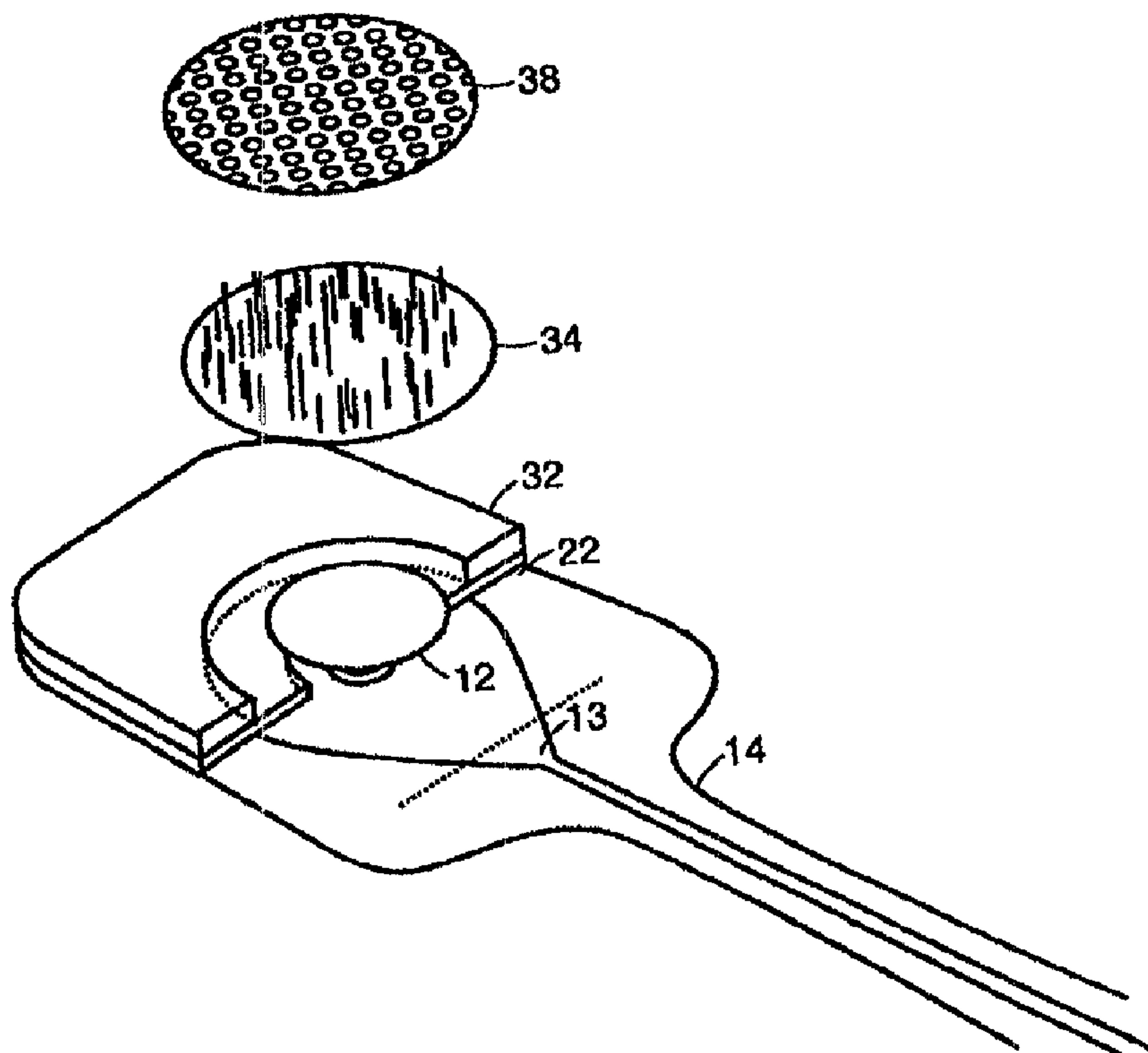

(86) Date de dépôt PCT/PCT Filing Date: 1999/06/18
 (87) Date publication PCT/PCT Publication Date: 1999/12/23
 (45) Date de délivrance/Issue Date: 2008/02/05
 (85) Entrée phase nationale/National Entry: 2000/12/05
 (86) N° demande PCT/PCT Application No.: US 1999/013849
 (87) N° publication PCT/PCT Publication No.: 1999/065389
 (30) Priorité/Priority: 1998/06/19 (US09/100,290)

(51) Cl.Int./Int.Cl. *A61B 5/04* (2006.01)
 (72) Inventeurs/Inventors:
 CORDERO, RAFAEL M., US;
 DEVLIN, PHILIP H., US
 (73) Propriétaire/Owner:
 ASPECT MEDICAL SYSTEMS, INC., US
 (74) Agent: SMART & BIGGAR

(54) Titre : ELECTRODE DE MESURE DE SIGNAUX ELECTROPHYSIOLOGIQUES AU MOYEN D'UN GEL
 ELECTROLYTIQUE LIQUIDE A FORTE TENEUR EN SEL
 (54) Title: ELECTRODE FOR MEASURING ELECTROPHYSIOLOGICAL SIGNALS USING LIQUID ELECTROLYTIC GEL
 WITH A HIGH SALT CONCENTRATION



(57) **Abrégé/Abstract:**

An electrophysiological electrode includes multiple layers of materials to isolate liquid electrolytic gels (39) from the conductive inks (13) on the flexible circuit (15) of the electrode substrate (14). Such an electrode has a much longer shelf life under normal storage conditions than other electrodes of such construction with high salt content liquid electrolytic gel, and is able to maintain acceptable impedance upon its eventual use.



PCT

WORLD INTELLECTUAL PROPERTY ORGANIZATION
International Bureau

INTERNATIONAL APPLICATION PUBLISHED UNDER THE PATENT COOPERATION TREATY (PCT)

<p>(51) International Patent Classification ⁶ : A61B 5/0408</p>	<p>A1</p>	<p>(11) International Publication Number: WO 99/65389</p> <p>(43) International Publication Date: 23 December 1999 (23.12.99)</p>
<p>(21) International Application Number: PCT/US99/13849</p> <p>(22) International Filing Date: 18 June 1999 (18.06.99)</p> <p>(30) Priority Data: 09/100,290 19 June 1998 (19.06.98) US</p> <p>(71) Applicant: ASPECT MEDICAL SYSTEMS, INC. [US/US]; 2 Vision Drive, Natick, MA 01760 (US).</p> <p>(72) Inventors: CORDERO, Rafael, M.; 987 South Street, Tewksbury, MA 01876 (US). DEVLIN, Philip, H.; 33 Clearwater Road, Brookline, MA 02167 (US).</p> <p>(74) Agents: BEVILACQUA, Michael, J. et al.; Hale and Dorr LLP, 60 State Street, Boston, MA 02109 (US).</p>		<p>(81) Designated States: AU, CA, JP, European patent (AT, BE, CH, CY, DE, DK, ES, FI, FR, GB, GR, IE, IT, LU, MC, NL, PT, SE).</p> <p>Published <i>With international search report.</i></p>

(54) Title: ELECTRODE FOR MEASURING ELECTROPHYSIOLOGICAL SIGNALS USING LIQUID ELECTROLYTIC GEL WITH A HIGH SALT CONCENTRATION

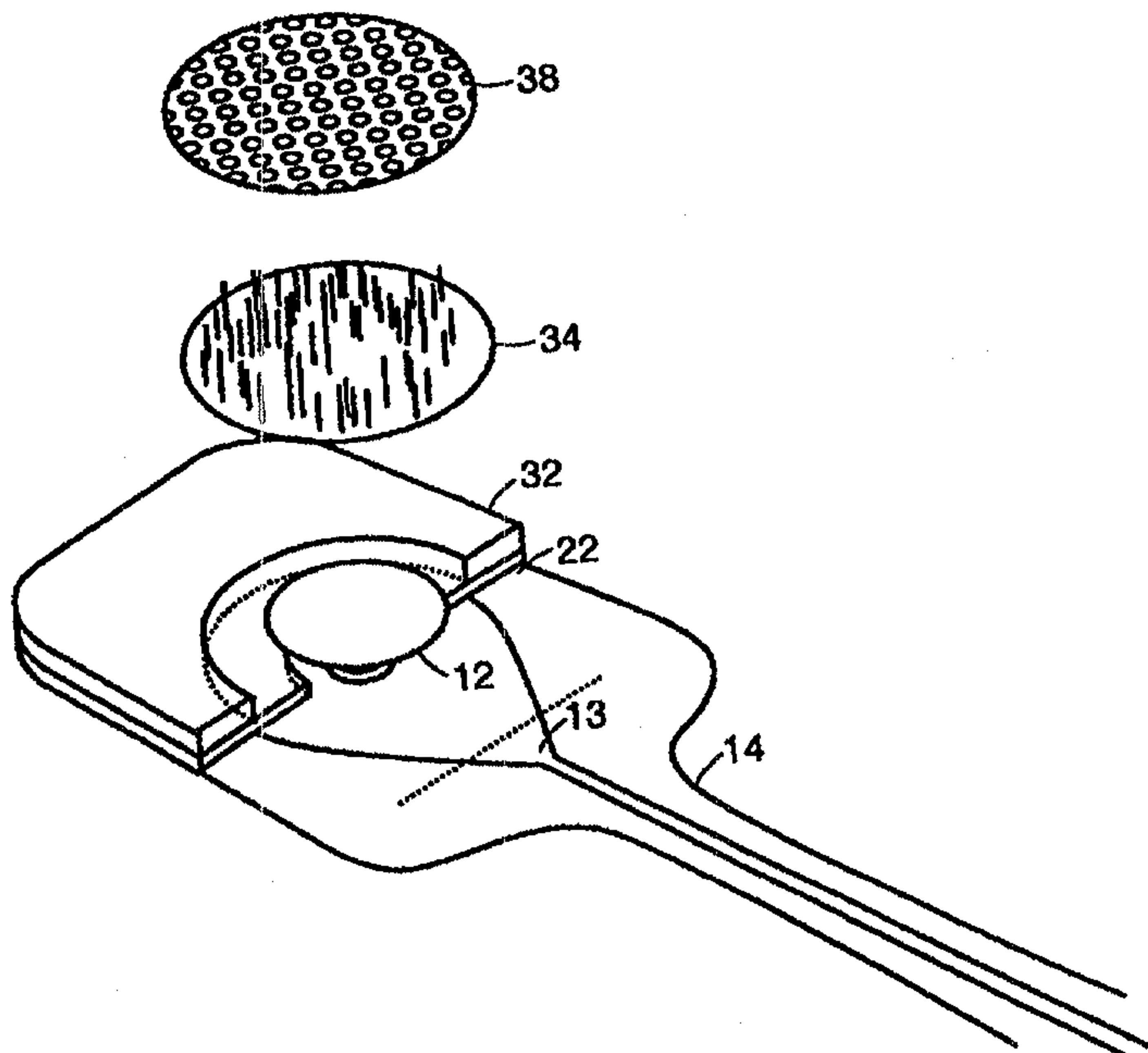

(57) Abstract

An electrophysiological electrode includes multiple layers of materials to isolate liquid electrolytic gels (39) from the conductive inks (13) on the flexible circuit (15) of the electrode substrate (14). Such an electrode has a much longer shelf life under normal storage conditions than other electrodes of such construction with high salt content liquid electrolytic gel, and is able to maintain acceptable impedance upon its eventual use.

Electrode For Measuring Electrophysiological Signals Using Liquid Electrolytic Gel With A High Salt Concentration

BACKGROUND OF THE INVENTION

Electrodes which are used to record biopotentials from the surface of the skin generally require the use of a conductive liquid or solid gel to provide a continuous conductive path between the recording surface (i.e., the skin) and the electrode sensing element. Conductive gels contain a salt (KCl or NaCl) in order to achieve electrical current flow. The preferred gel is one with a high salt content, since such a gel produces a better conductor than that obtained when using a gel with a low salt content. In addition, the use of a high salt content gel typically requires less skin abrasion at the time of application to reduce the impedance of the skin-electrode interface after subsequent electrode application.

For ease of use, it is desirable to apply the conductive liquid or solid gel at the point of manufacture, creating a "pre-gelled" electrode. US Patent No. 4,559,950 issued to Vaughn and US Patent No. 5,309,909 issued to Gadsby describe two such electrodes. Use of such electrodes saves the user the step of manually applying the gel to the electrode at the time of electrode application and speeds the application process considerably. Thus, the ideal electrode would be one pre-gelled with high salt content conductive gel. Such an electrode would minimize application time by reducing the amount of skin "prepping" (abrasion) required by low salt content gels and eliminating the step of dispensing the gel onto the electrode surface.

Numerous prior art references exist that show that one can make a pregelled electrode by chloriding the surface of a silver substrate to create a Ag/AgCl electrode element with a stable half cell potential. Often, a silver-plated plastic substrate is used instead of solid silver, for cost reasons. An electrolytic gel may then be applied at the

time of manufacture to create a pre-gelled electrode.

It is common in the art to construct single-piece sensors which incorporate multiple electrode elements on a single substrate. Such sensors have the advantages of low cost, ease of use, and precise positioning of the electrode elements. A common method of construction, as described in U.S. Patent No. 5,337,748 issued to McAdams, utilizes a flexible circuit, created by printing a circuit on a plastic substrate using conductive ink. The conductive ink makes up the electrode sensing element and provides an electrical connection between the individual electrode elements and a cable connector, which facilitates connection to a data acquisition system. The conductive ink generally consists of flakes of silver (Ag) in a liquid binder. U.S. Patent No. 4,852,572 issued to Nakahashi describes a pregelled, multiple electrode sensor constructed by printing a single layer of conductive ink on a non-woven cloth substrate. It is not possible, however, to pre-gel sensors constructed using conductive inks with liquid conductive gels because the salt content of the liquid gel quickly reacts with the Ag flakes in the ink and renders the circuit non-conductive. Such a process would lead to early sensor failure and a reduced shelf life. For this reason, sensors constructed using conductive inks are pre-gelled using a cured solid hydrogel with a low salt concentration. The use of a low salt content gel slows the rate at which the salt content of the gel corrodes the Ag element and therefore extends product shelf life. The impedance of the skin-electrode interface is generally higher than that which could be achieved with a high salt content gel, and the resultant electrical signal is much noisier. In addition, vigorous skin prepping is required to lower the impedance to an acceptable level, due to the limited hydrating properties of a solid gel.

Various prior art constructions exist which use multiple layers of conductive inks for low fidelity applications, such as the acquisition of resting EKG signals. One such construction is the TCP-3208 conductive coated polyester manufactured by Tolas

69675-483

a layer of conductive Ag/AgCl. The main purpose of this construction is to minimize the amount of silver (Ag) on a circuit trace, thus reducing the manufacturing cost. Such a construction generally makes use of solid hydrogel as the ionic interfacing material.

Another prior art construction, which is described in U.S. Patent No. 5,337,748 issued to McAdams includes a single layer of Ag or Ag/AgCl ink on a flexible substrate such as vinyl or Melinex* to make an electrode. Again, a solid hydrogel or a low concentration of salt in the liquid gel must be used in order to obtain an acceptable shelf life. Carrier in U.S. Patent No. 5,352,315, teaches the use of a single conductive ink layer of either Ag/AgCl or a homogenous mixture of Ag/AgCl and carbon inks printed on a nonconductive backing layer.

U.S. Patent No. 4,787,390 issued to Takata teaches the use of snap and eyelet type construction, though in this case the snap and eyelet is simply used to make mechanical contact between different components of the electrode and not to provide a pressure-sealed gel isolation function. U.S. Patent No. 4,444,194 issued to Burcham and U.S. Patent 4,617,935 issued to Cartmell also teach the use of a snap and eyelet construction, but only for the purpose of physically connecting electrode components.

It is therefore a principal object of the present invention to provide an electrophysiological electrode that utilizes a flexible circuit construction while allowing for the use of high salt content liquid electrolytic gels.

Another object of the present invention is to provide an electrophysiological electrode that contains a single interfacing contact to an electrophysiological monitor or other data acquisition system.

*Trade-mark

69675-483

It is a further object of the present invention to provide an electrophysiological electrode with pre-gelled electrodes which provide low impedance while reducing the need for skin preparation.

5 **SUMMARY OF THE INVENTION**

This invention is an electrophysiological electrode that includes multiple layers of materials to isolate liquid electrolytic gels from the conductive inks on the flexible circuit of the electrode substrate. Such an
10 electrode has a much longer shelf life under normal storage conditions than other electrodes of such construction with high salt content liquid electrolytic gel, and is able to maintain acceptable impedance upon its eventual use.

These and other objects and features of the
15 present invention will be more fully understood from the following detailed description which should be read in light of the accompanying drawings in which corresponding reference numerals refer to corresponding parts throughout the several views.

20 In accordance with this invention, there is provided an electrode for measuring electrophysiological signals, the electrode including a substrate of flexible non-conductive non-metallic material, a conductive metal ink deposited on said substrate characterized in that a
25 physically distinct barrier layer of silver/silver chloride (Ag/AgCl) is deposited over and contiguous with said conductive metal ink layer and in that said electrode includes a predispensed salt content based conductive gel, wherein said barrier layer isolates said conductive ink
30 layer from said conductive gel.

69675-483

BRIEF DESCRIPTION OF THE DRAWINGS

Figure 1 is a side elevational view of a preferred embodiment of an electrode of the present invention which uses a snap and eyelet assembly press fit onto a flexible circuit for electrical contact and a foam material for liquid seal.

Figure 2(a) is a top plan view of a sensor incorporating the electrodes shown in Figure 1.

Figure 2(b) is a side elevational view of the sensor shown in Figure 2(a) which shows the snap and eyelet function of making electrical contact and liquid sealing.

Figure 3 is an exploded perspective view of the embodiment of a sensor of the present invention shown in Figures 1, 2(a) and 2(b) in which the foam materials are partially cut away.

Figure 4 is an exploded perspective view of another preferred embodiment of the present invention which uses two passes of ink and an electrolytic gel over the ink.

Figure 5(a) is a top plan view of an alternate embodiment of a sensor of the present invention in which a Ag/AgCl screen is printed over Ag ink on a flexible substrate.

Figure 5(b) is a side elevational view of the sensor shown in Figure 4.

Figure 6 is an exploded perspective view of another preferred embodiment of the electrode of the present invention.

DETAILED DESCRIPTION OF THE PREFERRED EMBODIMENT

Referring to Figures 1-3, a preferred embodiment of an electrode 10 of the present invention is shown which makes use of a conductive Ag/AgCl-plated ABS (acrylo-nitrile butadiene styrene) plastic eyelet 12 attached to a flexible polyester substrate 14 by means of a pressure-fitted non-conductive plastic snap 16. A conductive trace 13 is printed on the underside of the flexible substrate 14 with Ag conductive ink such as Dupont 5000 screen printable ink, producing a flexible circuit 15. This flexible

circuit makes electrical contact with the eyelet 12 at the eyelet shoulder 18. The bottom 20 of the eyelet 12 is in contact with the liquid gel 39 (see Figure 2(b)). The eyelet bottom 20 is physically isolated from its shoulder 18 by a layer of foam 22 with a punched hole for the eyelet shoulder 18 and top 24 to pass through. The foam 22 prevents the liquid gel from coming into contact with the conductive Ag ink of the flexible circuit. In the preferred embodiment, the foam is 1/32" thick double-sided adhesive-backed polyethylene foam, an example of which is sold by MACTAC. The preferred diameter of the punched foam hole is 0.050" larger than the shoulder diameter. The preferred eyelet shoulder diameter is 0.22" and the preferred foam hole diameter is 0.27 inches.

In a preferred embodiment shown in Figure 2, the snap and eyelet assembly is integrated into a multiple electrode element sensor 30. Figure 2 also more clearly shows the additional components of a multiple element sensor constructed using multiple snap and eyelet electrode assemblies 10.

In the preferred embodiment shown in Figure 2(b), the plastic snap 16 is pressed down over the top of the eyelet 12, sandwiching the flexible circuit 15 and the foam seal layer 22 between the eyelet 12 and the snap 16. A basepad layer 32 of 1/16" double-sided adhesive foam is placed below the foam seal layer 22. As shown most clearly in Figure 3, the top side of the basepad layer 32 (shown with a portion cut away) adheres firmly to the foam of the seal layer 22 and it contains a circular hole of 0.6" diameter concentric to the eyelet creating a cylindrical housing to contain the liquid gel. The foam of the basepad layer 32 is made of the same foam as that of the seal layer 22.

The preferred embodiment utilizes a studded, porous spacer made of a disc 34, 0.6 inches in diameter, stamped out of Velcro hook material. The hook material has been sheared to make tines that will serve as a skin prepping mechanism when the user

69675-483

presses against them during use, in the same manner as described in U.S. Patent No. 5,305,746 issued to Fendrock and assigned to the assignee of the present application. The backing 36 of the Velcro^{*} material is porous. The preferred Velcro^{*} thickness (including backing and tine profile) is approximately 0.08 inches. The liquid gel 39 is held in the gel pocket by a porous sponge 38, which is a urethane open pore sponge in the preferred embodiment.

The pressure exerted by the snap fit between the snap 16 and the eyelet 12 provides constant electrical contact between the eyelet 12 and the conductive trace 13 of the flexible printed circuit 15 at the shoulder 18 of the eyelet 12.

The pressure fit assembly also sandwiches the foam seal layer 22 between the snap 16 and the eyelet 12. This gaskets the top area of the eyelet and produces a tight seal which keeps the liquid gel 39 from contacting the flexible circuit 15. As a result, the gel is confined to the gel pocket below the bottom surface of the eyelet 12 and is not allowed to come in contact with the conductive Ag ink on the flexible circuit. The preferred conductive liquid gel is 10% salt content liquid hydrogel.

The flexible circuit 15 is connected to a cable connector 40, which allows connection of the electrode to a data acquisition system (not shown).

Another embodiment which accomplishes the goal of isolating the conductive Ag ink from the high salt content conductive gel is shown in Figures 4, 5(a) and 5(b). In this alternate embodiment, a flexible circuit 50 is created by printing a layer of conductive Ag ink 52 on a flexible plastic substrate (Mylar^{*}) 54. Isolation of the Ag conductor from the gel is accomplished by printing an eyelet layer 56 of Ag/AgCl ink

*Trade-mark

(Acheson 7019™ in the preferred embodiment) over the conductive Ag ink 52. The eyelet layer 56 serves the same function as the eyelet 12 in the snap and eyelet embodiment shown in Figure 1.

A basepad 58 (shown with a portion cut away) of 1/16" double-sided adhesive foam with a circular hole of 0.6" diameter, is placed onto the plastic substrate 54 so that the hole is centered concentric to the eyelet. This hole in the basepad 58 creates a cylindrical housing which is used to contain the liquid gel. Additionally, there is a studded, porous spacer disc 60, 0.6 inches in diameter, stamped out of Velcro hook material. The hooks 62 on the disc 60 have been sheared to make tines that will serve as a skin prepping mechanism when the user presses against them during use. The backing of the disc 60 is porous to allow the gel to go through it and provides full conductivity in the direction perpendicular to the electrode substrate. The preferred Velcro thickness including the tine profile is approximately 0.08 inches. The liquid gel is held in the cylindrical housing by a porous spacer sponge 66 made out of urethane porous material which is impregnated with the liquid gel.

The flexible printed conductive circuit 50 electrically connects the electrode element to a cable connector 40 (Figure 5(a)). The cable connector allows connection of the sensor to a data acquisition system.

Placing a layer of chlorided material over the non-chlorided conductive material as described above provides the following benefits over prior art:

- The Ag/AgCl surface serves the same purpose of the eyelet in the embodiment shown in Figure 1, electrically interfacing to the conductive gel. It also provides a limited isolation of the conductive Ag layer from the corrosive effects of the conductive gel. The isolation is limited because the screen printing process creates a porous Ag/AgCl

surface that is not completely impermeable.

- Because AgCl is not initially present in the bottom layer, any increase in AgCl in the Ag layer resulting from chloriding reactions which occur between the conductive gel and the metal (Ag) flakes in the conductive ink will cause the concentration of AgCl in the Ag layer to increase from zero rather than from an initial concentration greater than zero. This extends the life of the product by providing more Ag flakes at the start which translates to more conductive paths.
- In addition, because there are no large molecules of AgCl in the underlying conductive layer, the Ag flakes are closely bound together and prevent the electrolyte from penetrating any large gaps left unfilled by the binding substrate of the ink. This slows down the chloriding process. In addition, the Ag flakes are closely bound together and thus maintain a higher conductivity than a Ag/AgCl ink. This translates to less noise overall during data collection.

Other alternate embodiments utilize carbon, nickel, copper or other metal inks on the bottom layer instead of silver for electrodes that do not require high noise sensitivity.

Another alternate embodiment utilizes solid instead of liquid hydrogels. While solid hydrogels have lower conductivities than liquid gels, their use can be advantageous for sensors which incorporate closely-spaced multiple electrode sensors. In such an application, the higher material crosslinking of the solid hydrogel prevents shorting of the electrode elements due to gel migration, which would occur if liquid gels were used. This embodiment allows the use of solid hydrogels with higher salt content than is commonly used while still achieving the same intent to maximize shelf life.

The embodiment of the electrode of the present invention shown in Figure 6 utilizes a layer of solid hydrogel 70 as a barrier layer between the conductive ink 52 and the liquid gel impregnated in the sponge 66. This construction uses an Ag/AgCl conductive ink and the layer of solid hydrogel 70 acts as an exchange barrier between the conductive ink 52 and the liquid gel.

While the foregoing invention has been described with reference to its preferred embodiments, various alterations and modifications will occur to those skilled in the art. For example, while various dimensions are recited above for components of the present invention, it should be understood that these are simply the preferred dimensions and that differently sized components could be used and different number of electrodes could be incorporated on a sensor and still achieve the intended results.

69675-483

CLAIMS:

1. An electrode for measuring electrophysiological signals, the electrode including a substrate (14) of flexible non-conductive non-metallic material, a conductive metal ink (13) deposited on said substrate (14) characterized in that a physically distinct barrier layer (56) of silver/silver chloride (Ag/AgCl) is deposited over and contiguous with said conductive metal ink layer and in that said electrode includes a predispensed salt content based conductive gel (39), wherein said barrier layer isolates said conductive ink layer from said conductive gel.
2. The electrode of claim 1 wherein said barrier layer (56) comprises a component plated with Ag/AgCl material.
3. The electrode of claim 1 wherein said barrier layer (56) comprises a screen printed ink layer of Ag/AgCl material.
4. The electrode of claim 1 wherein said barrier layer (56) comprises a flexo-printed ink layer of Ag/AgCl material.
5. The electrode of claim 1 wherein said conductive metal ink layer (13) is silver (Ag).
6. The electrode of claim 1 wherein said conductive gel (39) is a liquid electrolytic gel.
7. The electrode of claim 1 wherein said conductive gel (39) is a solid hydrogel gel.
8. The electrode of claim 1 wherein printed graphics are printed on a side of said flexible substrate (14)

69675-483

opposite the side where said conductive metal ink layer is located.

9. The electrode of claim 1 further characterized in that a ring or pad (58) of nonconductive material positioned
5 between a surface of said substrate (14) bearing said conductive ink circuit (13) and a layer of Ag/AgCl material (56), said layer of nonconductive material (58) extending from the outer edge of the layer of Ag/AgCl material (56) to act as an isolating gasket to completely
10 separate the conductive ink circuit (13) from the conductive gel.

10. The electrode of claim 1 wherein said conductive metal ink (13) is Ag/AgCl and said barrier layer (56) is a polymer layer of hydrogel.

15 11. The electrode of claim 1 wherein said barrier layer (56) is a polymer layer of hydrogel (70).

12. The electrode of claim 9 wherein said nonconductive layer (58) is a transfer film.

13. The electrode of claim 9 wherein said
20 nonconductive layer (58) is a double coated adhesive foam backing.

14. The electrode of claim 9 wherein said layer of Ag/AgCl material is secured to the barrier layer (56) and flexible substrate (14) by means of a non-conductive snap or
25 ring (16, 20) that is pressure fit to said Ag/AgCl layer (56).

15. The electrode of claim 9 wherein said conductive ink circuit (13) is made of carbon ink.

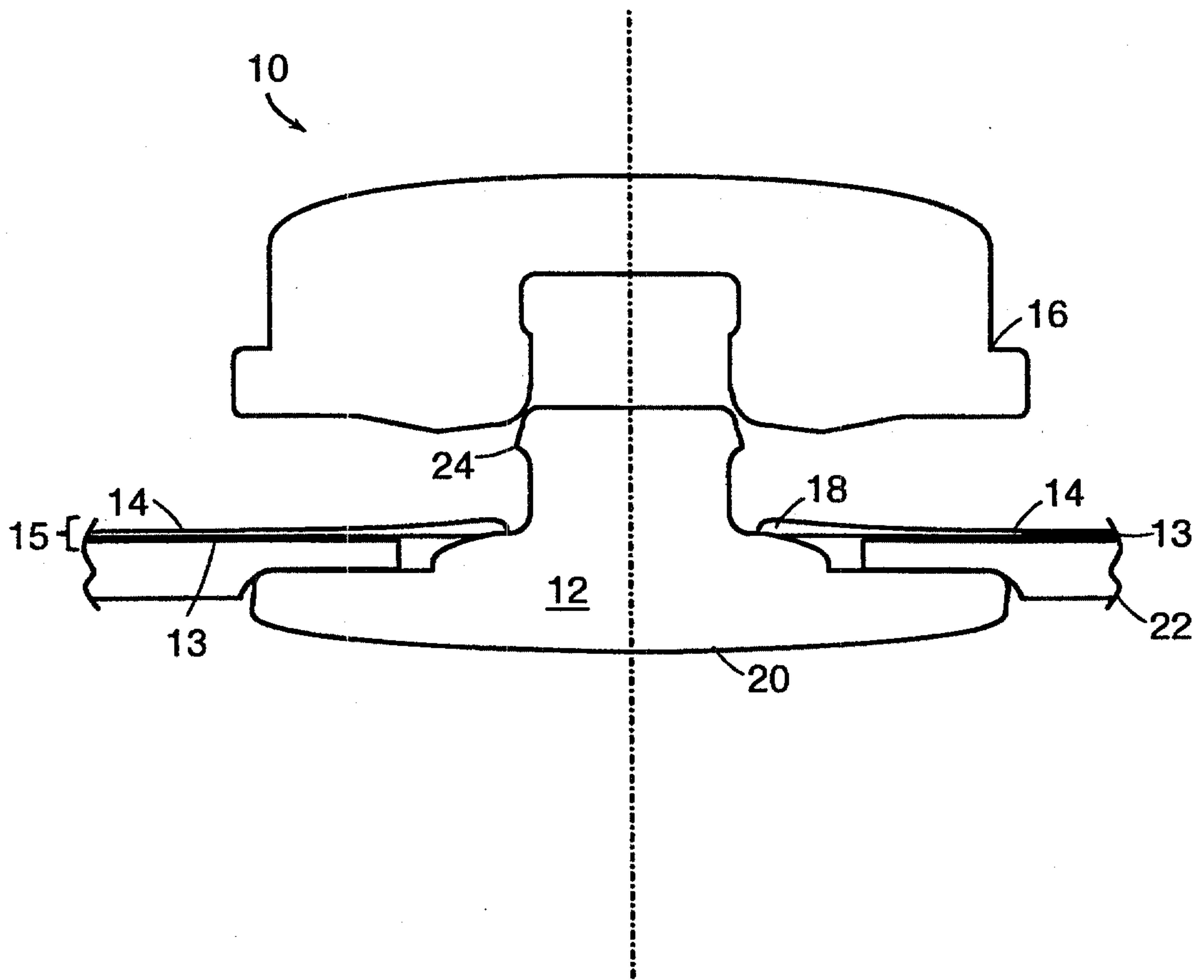

FIG. 1

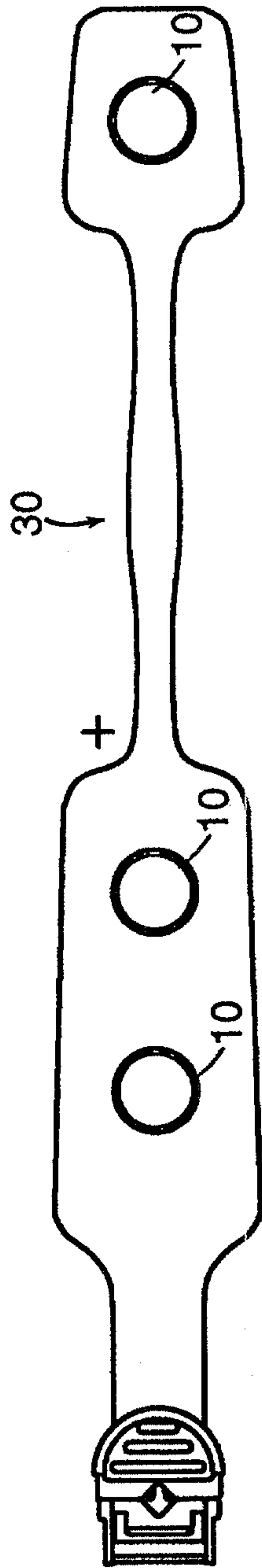

FIG. 2a

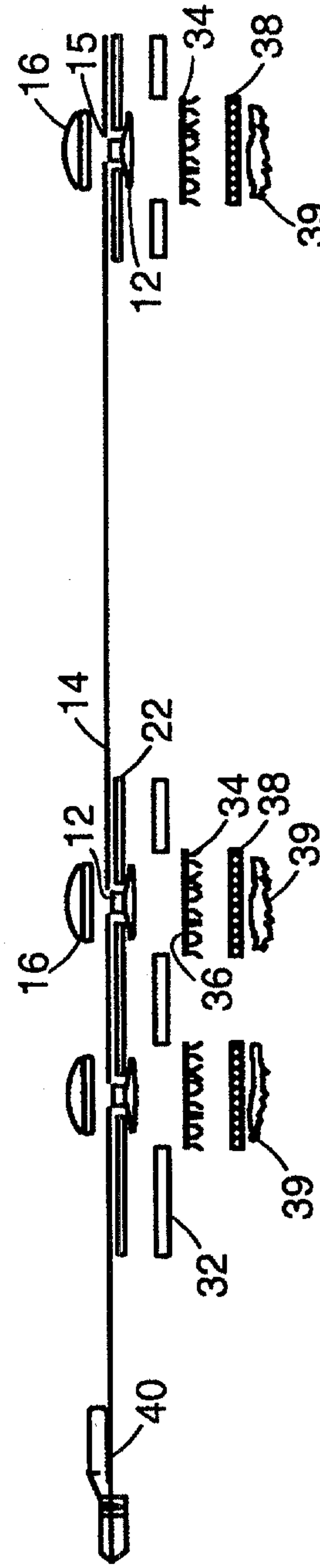

FIG. 2b

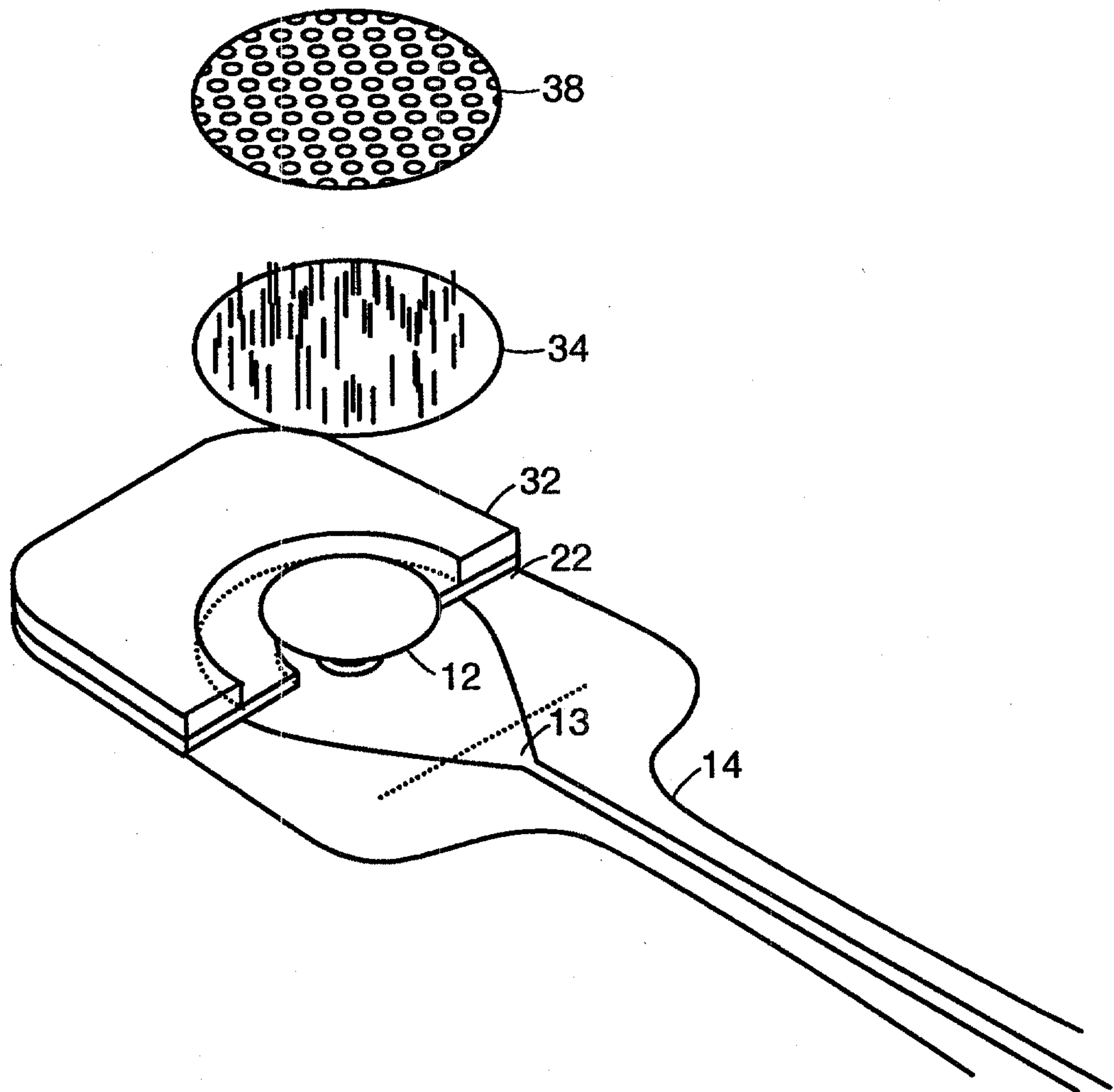

FIG. 3

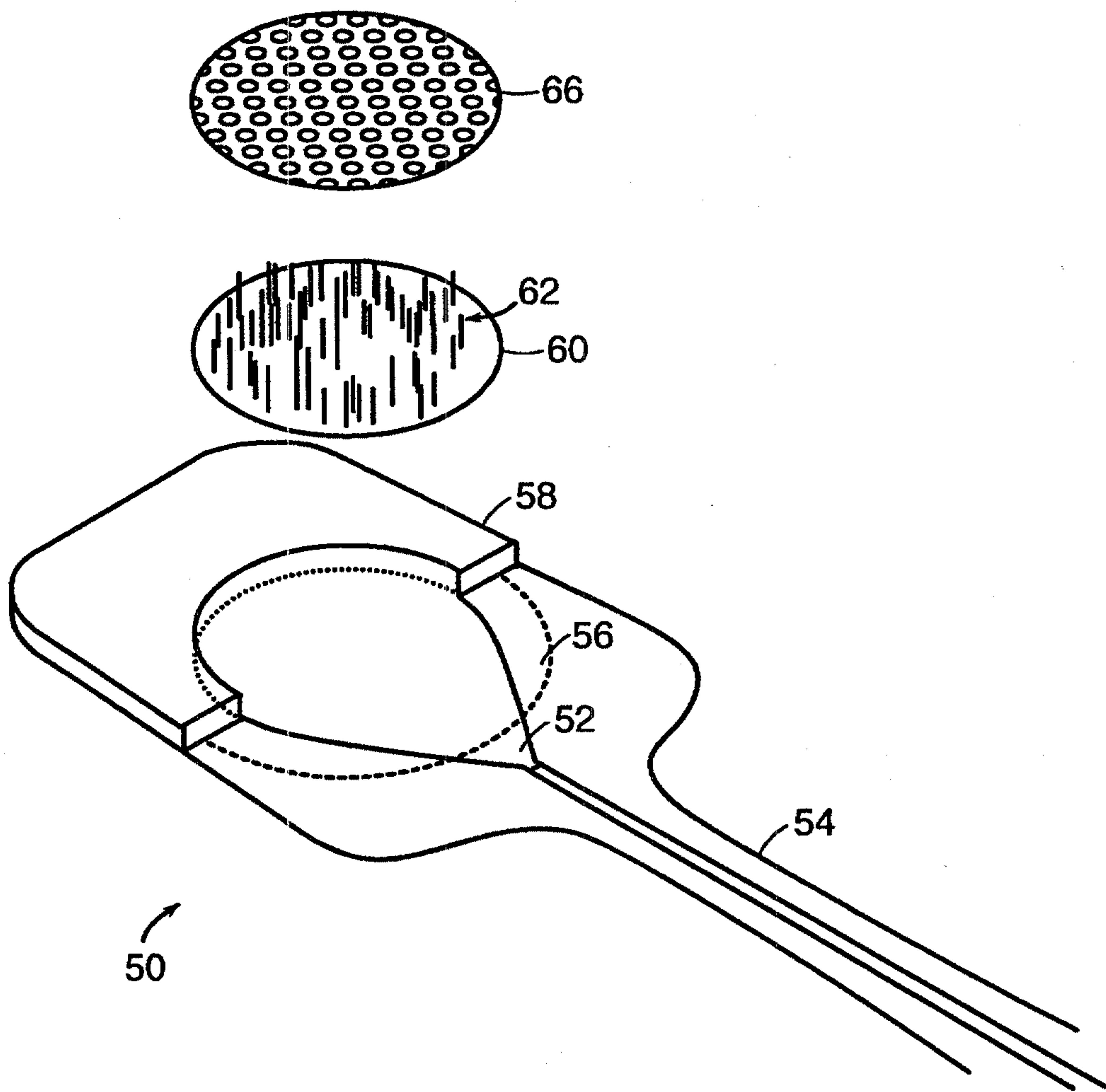

FIG. 4

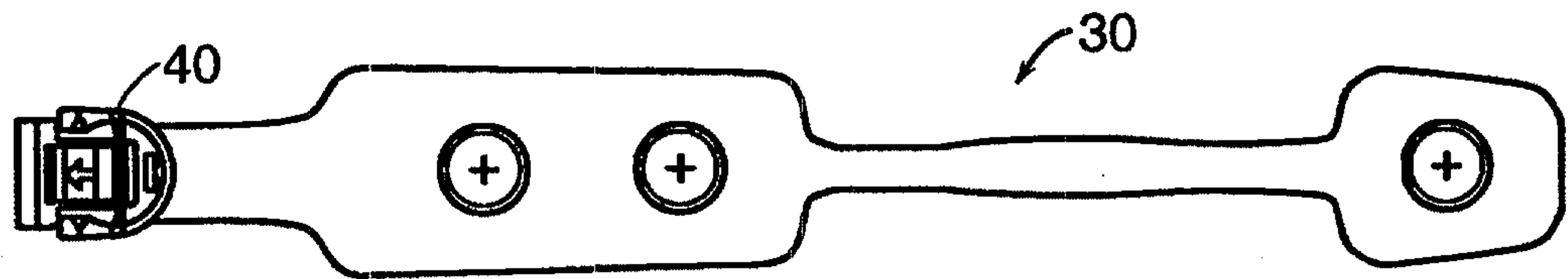

FIG. 5a

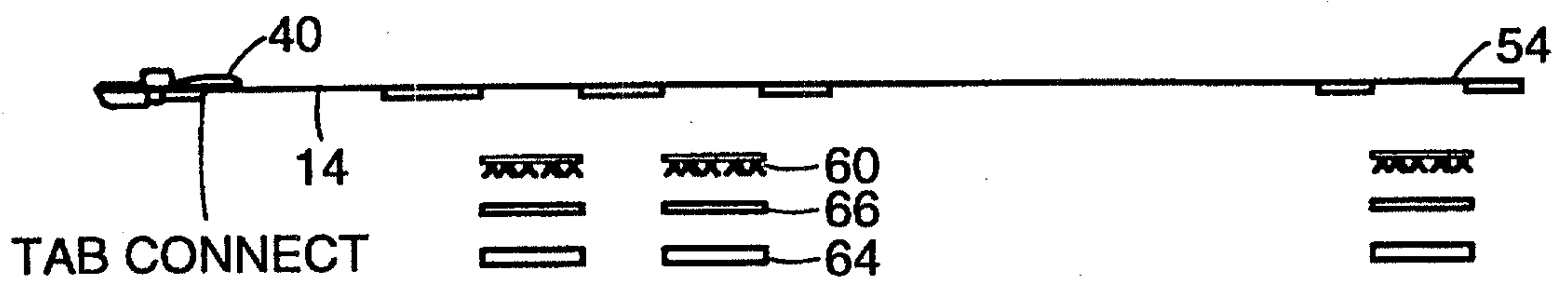

FIG. 5b

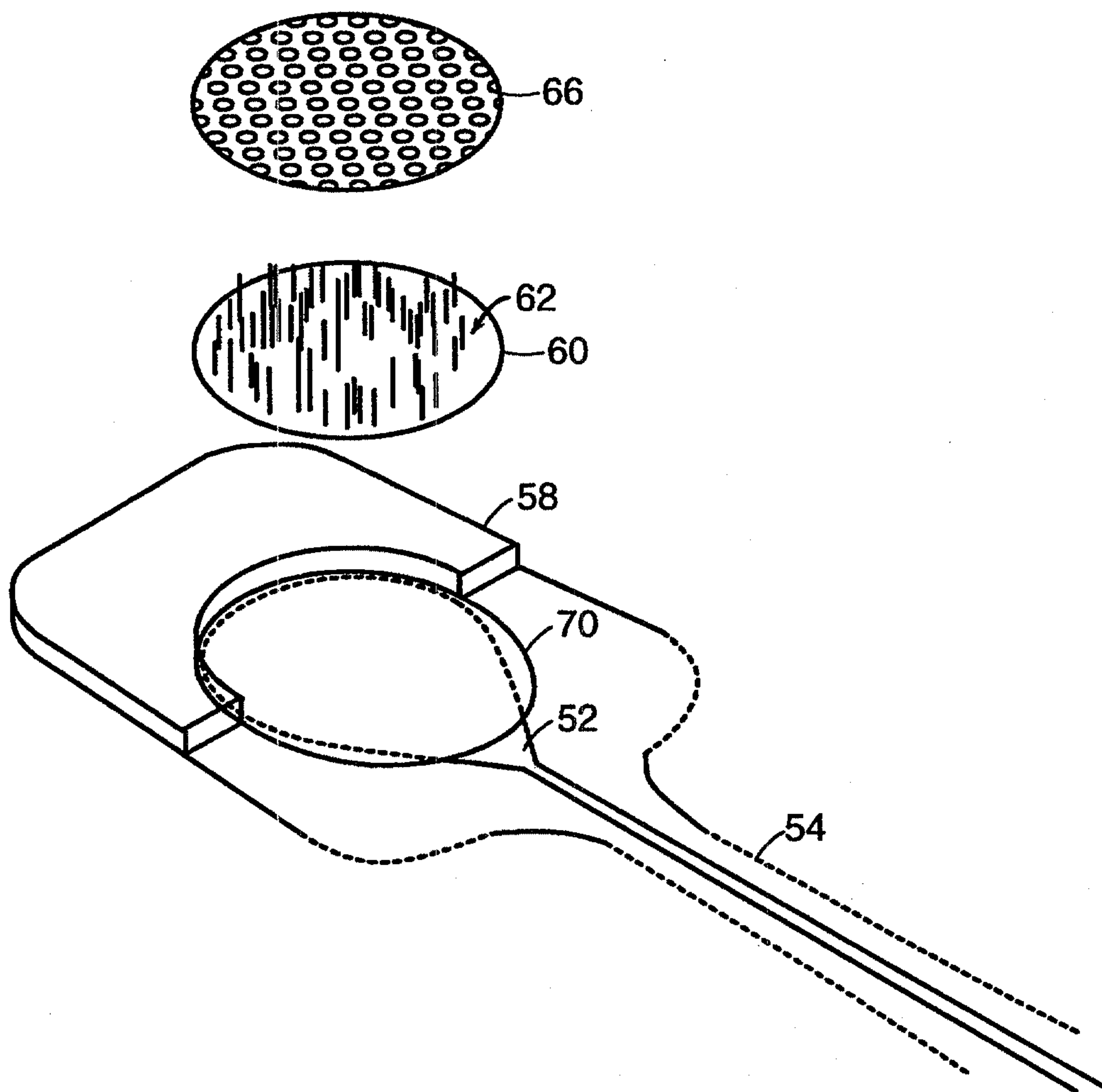

FIG. 6

