

(19)



Europäisches Patentamt

European Patent Office

Office européen des brevets



(11)

EP 0 634 121 B1

(12)

EUROPEAN PATENT SPECIFICATION

(45) Date of publication and mention
of the grant of the patent:

09.10.1996 Bulletin 1996/41

(51) Int. Cl.⁶: **A47B 96/06**, A47B 96/02

(21) Application number: **94830177.5**

(22) Date of filing: **14.04.1994**

(54) An invisible support for fixing shelves to walls

Unsichtbarer Halter zur Wandbefestigung von Regalen

Support invisible pour fixer des étagères à des murs

(84) Designated Contracting States:
**AT BE CH DE DK ES FR GB GR IE IT LI LU MC NL
PT SE**

(30) Priority: **25.05.1993 IT BO930239**

(43) Date of publication of application:
18.01.1995 Bulletin 1995/03

(73) Proprietor: **DECORLEGNO S.r.l.
60010 Casine di Ostra (Ancona) (IT)**

(72) Inventor: **Montesi, Riccardo
I-60019 Senigallia (AN) (IT)**

(74) Representative: **Lanzoni, Luciano
c/o BUGNION S.p.A.
Via Cairoli, 107
47037 Rimini (Forli) (IT)**

(56) References cited:
**DE-A- 2 258 412 GB-A- 2 232 345
US-A- 4 381 715**

EP 0 634 121 B1

Note: Within nine months from the publication of the mention of the grant of the European patent, any person may give notice to the European Patent Office of opposition to the European patent granted. Notice of opposition shall be filed in a written reasoned statement. It shall not be deemed to have been filed until the opposition fee has been paid. (Art. 99(1) European Patent Convention).

Description

The invention relates to an invisible support for fixing shelves and the like against walls, of the type having at least one horizontal element which can be inserted in a complementarily-shaped cavity in a shelf and which vertically constrains the shelf to the support.

In the field of internal decoration, as is known, the above type of shelf is commonly used because of its aesthetic characteristics, which largely derive from the fact that the support of the shelf is totally hidden from view.

For this aim, one or more cavities, shaped complementarily to the supports, are made in the wall, which cavities are accessible from the side of the shelf facing the wall.

Known-type invisible supports, of whatever materials and variables, are always made in such a way as to constrain the shelf only in a vertical direction, but never in a horizontal direction too, due to the fact that the shelf has to be unslidable from the support bracket.

This, however, constitutes a considerable drawback, especially regarding the safety of children who might swing from the shelves or slide them outwards in play, with obvious danger both to themselves and the objects perched on the shelves. This is in fact so dangerous that many of the more safety-conscious countries have already banned the use of such fittings.

To encounter this grave problem, glues are sometimes used between the support and the cavities in the shelf, but here also drawbacks are inherent due to the slowness of their effectiveness after application, and also due to the variability of glue effectiveness, which depends on such things as the play between the shelf cavities and the support during the assembly operation.

The aim of the present invention, as it is characterized in the claims that follow, is thus to eliminate the above-mentioned drawbacks. The invention achieves its set aim by providing an invisible support having a horizontal element which can be inserted in a cavity in the shelf and comprising at least one adjustable barb which is hidden in the cavity and which interacts with the walls of the shelf in such a way as to permit free horizontal movement of the shelf when neared to the support, but preventing its backwards movement, that is, its opposite horizontal movement away from the wall.

The support is characterized in that it is extremely economical and in that the shelf constraint in a horizontal direction is very rapid, effective, and has no need of glues and/or further intermediate elements.

A further advantage of the invention is that the barb can perform its task under any circumstances and independently of the size of the assembly play between the support and the cavity. The play is always annulled by the barb which, thanks to its elastic fin elements, always takes up the slide play, thus blocking the shelf and the support rigidly.

Further advantages of the present invention will better emerge from the detailed description that follows,

of an embodiment of the invention, illustrated in the form of a non-limiting example in the accompanying drawings, in which:

- 5 figure 1 shows a shelf and relative support in a perspective exploded view;
- figure 2 shows in enlarged scale a perspective view of the support and a shelf associated to a wall and sectioned according to the section line III-III of figure 1;
- 10 figure 4 shows an exploded perspective view of a first embodiment of the invention;
- figure 5 shows a total and partially sectioned view of a second embodiment of the invention;
- 15 figure 6 shows a detail of the embodiment of figure 5, in perspective view;
- figure 7 shows a posterior view, with some parts removed, of the support of figure 4 mounted on a shelf.

With reference to the figures, the invention essentially consists of an invisible support 6 for fixing shelves 1 to walls 5.

- 25 The support 6 of figure 1 comprises a horizontal element 2 arranged over the entire length of the support 6, and is insertable in a cavity 3 which is complementary in size to the shelf 1. The horizontal element 2, preferably made in a single body with a vertical element 12 which is conventionally screwable to the wall 5, as in figure 3, constrains the shelf 1 to the support 6 in a vertical direction 10, and is in continuous supporting connection over its entire length.

- 30 The support 6 has several barbs 4 along its horizontal element 2, which can be seen clearly in figures 2 and 3, which barbs 4 will be hidden in the cavities 3 and which interact between the horizontal element 2 and at least a wall 5 of the cavity 3 such as to permit free horizontal movement of the shelf 1 with respect to the support 6 during the nearing phase, but preventing a retrograde movement of the same.

- 35 The barb 4 comprises at least one flaring element 7 made in a single body with the horizontal element 2 and supported by the said element 2, from which it flares out towards the wall 5 of the cavity 3, in such a way as to snag into the shelf and prevent its retrograde horizontal movement.

- 40 The flaring element 7 elastically meets the wall of the cavity and annuls any play existing between the horizontal element 3 and the cavity 3.

- 45 The flaring element acts in a transversal direction 10 to the horizontal direction of the relative movement between the shelf 1 and the support 6 and, if the construction is as in figure 3, in which the transversal direction 10 coincides with the vertical direction, implicates the further advantage of preventing the shelf from wobbling on the support 6.

- 50 With reference to the figures, the flaring element 7 is preferably arranged at a slot 8 made in the horizontal element 2 and arranged across it. This solution has the

advantage of permitting a sure guide to a tool stem, such as a simple screwdriver, to enable the flaring element to be positionally adjusted. From the figures it can be understood that when the support 6 is made of metal, or in another plastically deformable material, and the position of the flaring element 7 in the slot 8 can be adjusted by causing plastic deformations on the flaring element 7 up until the shelf 1 is constrained to the support with the desired force.

The invention is susceptible to numerous modifications and variations, all entering within the inventive field; furthermore, all of the details can be substituted by technically equivalent elements.

In figure 4 one possible variant is illustrated, where the horizontal element 2 is a straight rod having a polygonal section, and can be inserted in a cylindrical cavity 3 in the shelf 1. The barb 4 can be made of a horizontal flaring element 7 having one partially hooked end 35 and supported to a washer 30 which can be slotted on a pivot 31 of the horizontal element 2.

The flaring element 7 (see figure 7) can be inserted between the wall 5 of the cylindrical cavity 3 and the edge 33 of the horizontal element 2 circumscribed by the wall 5. A milled groove 32 is made on the horizontal element 2, against the bottom of which groove 32 the flaring element 7 reacts elastically to exert its above-described action on the cavity 3 of the shelf 1.

Figures 5 and 6 show a further embodiment in which the barb 4 has two opposite flaring elements 7 made in a cylindrical bush 36 (see figure 6), which bush is slidably associated in a correspondingly cylindrical tract 37 of the horizontal element 2.

Claims

1. An invisible support for fixing shelves to walls, comprising at least one horizontal element (2) which can be inserted in a cavity (3) in a shelf (1), such that the shelf is vertically constrained to the support (6), said support (6) being characterised in that it comprises at least one adjustable barb (4) which on assembly can be hidden in the cavity (3) and which interacts between the horizontal element (2) and at least one wall (5) of the cavity (3) in such a way as to permit free horizontal movement of the shelf (1) when neared to the support (6), but preventing the shelf (1) from returning outwardly.
2. A support as in claim 1, characterised in that the barb (4) comprises at least one flaring element (7) supported to the horizontal element (2) and projecting towards the wall (5) such that the flaring element (7) horizontally contrasts the shelf (1) elastically in a transversal direction.
3. A support as in claim 1, characterised in that the flaring element (7) is made in a single body with the horizontal element (2).
4. A support as in claim 1, wherein the horizontal element (2) has a straight rod shape with a polygonal profile, and is insertable in a cylindrical cavity (3), characterised in that the barb (4) comprises at least one flaring element (7) arranged longitudinally to the horizontal element (2) and supported by a washer (30) slottable on to a pivot (31) of the horizontal element (2), said flaring element (7) being provided with one at least partially hooked end destined to react against the wall (5) of the cavity (3) in such a way as to prevent a backsliding of the shelf from the support (6).
5. A support as in claim 1, characterised in that the barb (4) comprises at least one flaring element (7) made on a bush (36), said bush (36) being slidably associated to a tract (37) of the horizontal element (2).
6. A support as in claim 2 or 3, characterised in that the flaring element (7) is arranged at a slot (8) made in the horizontal element (2).
7. A support as in claim 4, characterised in that the horizontal element (2) has a channel (32) for housing the flaring element (7), said flaring element (7) engaging against the wall (5) of the cavity (3) and reacting elastically against a bottom (34) of the channel (32).
8. A support as in claim 5, characterised in that the barb (4) has two opposite flaring elements (7).
9. A support as in claim 6, characterised in that the slot (8) is arranged across the horizontal element (2).

Patentansprüche

1. Unsichtbarer Halter zur Wandbefestigung von Regalen, wenigstens ein Horizontalelement (2) enthaltend, das in einen Hohlraum (3) in einem Regal (1) derart eingeführt werden kann, daß das Regal vertikal mit dem Halter (6) befestigt wird, wobei der besagte Halter (6) dadurch gekennzeichnet ist, daß er mindestens eine einstellbare Spitze (4) enthält, die im montierten Zustand in dem Hohlraum (3) verborgen werden kann und die zwischen dem Horizontalelement (2) und wenigstens einer Wand (5) des Hohlraums (3) derart in Wechselwirkung steht, daß eine freie Horizontalbewegung des Regals (1) erlaubt wird, wenn sie an den Halter (6) genähert wird, jedoch verhindernd, daß das Regal (1) nach außen zurückbewegt wird.
2. Halter, nach Anspruch 1, dadurch gekennzeichnet, daß die Spitze (4) wenigstens ein Stemmelement (7) enthält, das an dem Horizontalelement (2) abgestützt ist und zur Wand (5) hin derart hervor-

ragt, daß das Stemmelement (7) horizontal relativ zum Regal (1) in Querrichtung elastisch entgegenwirkt.

3. Halter, nach Anspruch 1, dadurch gekennzeichnet, daß das Stemmelement (7) zusammen mit dem Horizontalelement (2) als einzelner Körper ausgebildet ist. 5
4. Halter, nach Anspruch 1, wobei das Horizontalelement (2) eine gerade Stabform mit einem polygonalen Profil aufweist und in einen zylindrischen Hohlraum (3) einführbar ist, dadurch gekennzeichnet, daß die Spitze (4) wenigstens ein Stemmelement (7) aufweist, das zum Horizontalelement (2) in Längsrichtung angeordnet ist und durch eine Unterlegscheibe (30) auf einem Zapfen (31) des Horizontalelements (2) einpaßbar gehalten wird, wobei das besagte Stemmelement (7) mit einem wenigstens teilweise gekrümmten Ende versehen ist, das dazu vorgesehen ist, gegen die Wand (5) des Hohlraums (3) derart entgegenzuwirken, daß ein Zurückgleiten des Regals von dem Halter (6) verhindert wird. 10
15
20
5. Halter, nach Anspruch 1, dadurch gekennzeichnet, daß die Spitze (4) wenigstens ein Stemmelement (7) aufweist, das auf einer Hülse (36) ausgebildet ist, wobei die besagte Hülse (36) verschiebbar mit einem Flächenanteil (37) des Horizontalelements (2) verbunden ist. 25
30
6. Halter, nach Anspruch 2 oder 3, dadurch gekennzeichnet, daß das Stemmelement (7) an einer Spalte (8) angeordnet ist, die im Horizontalelement (2) ausgebildet ist. 35
7. Halter, nach Anspruch 4, dadurch gekennzeichnet, daß das Horizontalelement (2) einen Kanal (32) zur Aufnahme des Stemmelements (7) aufweist, wobei das Stemmelement (7) gegen die Wand (5) des Hohlraums (3) in Eingriff steht und elastisch gegen den Grund (34) des Kanals (32) wirkt. 40
8. Halter, nach Anspruch 5, dadurch gekennzeichnet, daß die Spitze (4) zwei gegenüberliegende Stemmelemente (7) aufweist. 45
9. Halter, nach Anspruch 6, dadurch gekennzeichnet, daß der Spalt (8) quer über das Horizontalelement (2) angeordnet ist. 50

Revendications

1. Un support invisible pour fixer des étagères à des murs, comprenant au moins un élément horizontal (2) qui peut être introduit dans une cavité (3) d'une étagère (1), de manière à ce que l'étagère soit mise en contrainte de façon verticale contre le support 55

(6), ledit support (6) étant caractérisé en ce qu'il comprend au moins un barbillon réglable (4) qui lors de l'assemblage peut être caché dans la cavité (3) et qui interagit entre l'élément horizontal (2) et au moins une paroi (5) de la cavité (3) de manière à permettre à l'étagère (1) d'effectuer un mouvement horizontal libre lorsqu'elle est rapprochée du support (6), mais empêchant ladite étagère (1) d'effectuer un mouvement vers l'extérieur.

2. Un support selon la revendication 1, caractérisé en ce que le barbillon (4) comprend au moins un élément évasé (7) supporté par l'élément horizontal (2) et projetant en saillie vers la paroi (5) de manière à ce que l'élément évasé (7) agissent en tant que butée horizontale contre la dite étagère (1) de manière élastique dans une direction transversale.
3. Un support selon la revendication 1, caractérisé en ce que l'élément évasé (7) constitue un corps unique avec l'élément horizontal (2).
4. Un support selon la revendication 1, caractérisé en ce que l'élément horizontal (2) en forme de tige présente un profil polygonal, et qu'il peut être introduit dans une cavité cylindrique (3), caractérisé en ce que le barbillon (4) comprend au moins un élément évasé (7) placé longitudinalement et supporté par une rondelle (30) pouvant être enfilée sur un pivot (31) de l'élément horizontal (2), ledit élément évasé (7) présentant une extrémité partiellement en forme de crochet destinée à agir contre la paroi (5) de la cavité (3) de manière à ce que ladite étagère (1) ne puisse pas glisser du support (6).
5. Un support selon la revendication 1, caractérisé en ce que le barbillon (4) comprend un élément évasé (7) réalisé sur une bague (36), ladite bague (36) étant associée de manière coulissante à une portion (37) de l'élément horizontal (2).
6. Un support selon les revendications 2 et 3, caractérisé en ce que l'élément évasé (7) est placé dans une fente (8) présente sur l'élément horizontal (2).
7. Un support selon la revendication 4, caractérisé en ce que l'élément horizontal (2) présente une rainure (32) destinée à loger l'élément évasé (7) qui s'engage contre la paroi (5) de la cavité (3) et réagissant de manière élastique contre une partie inférieure (34) de la rainure (32).
8. Un support selon la revendication 5, caractérisé en ce que le barbillon (4) possède deux éléments évasés (7) opposés.

9. Un support selon la revendication 6, caractérisé en ce que la fente (8) est placée en travers de l'élément horizontal (2).

5

10

15

20

25

30

35

40

45

50

55

5

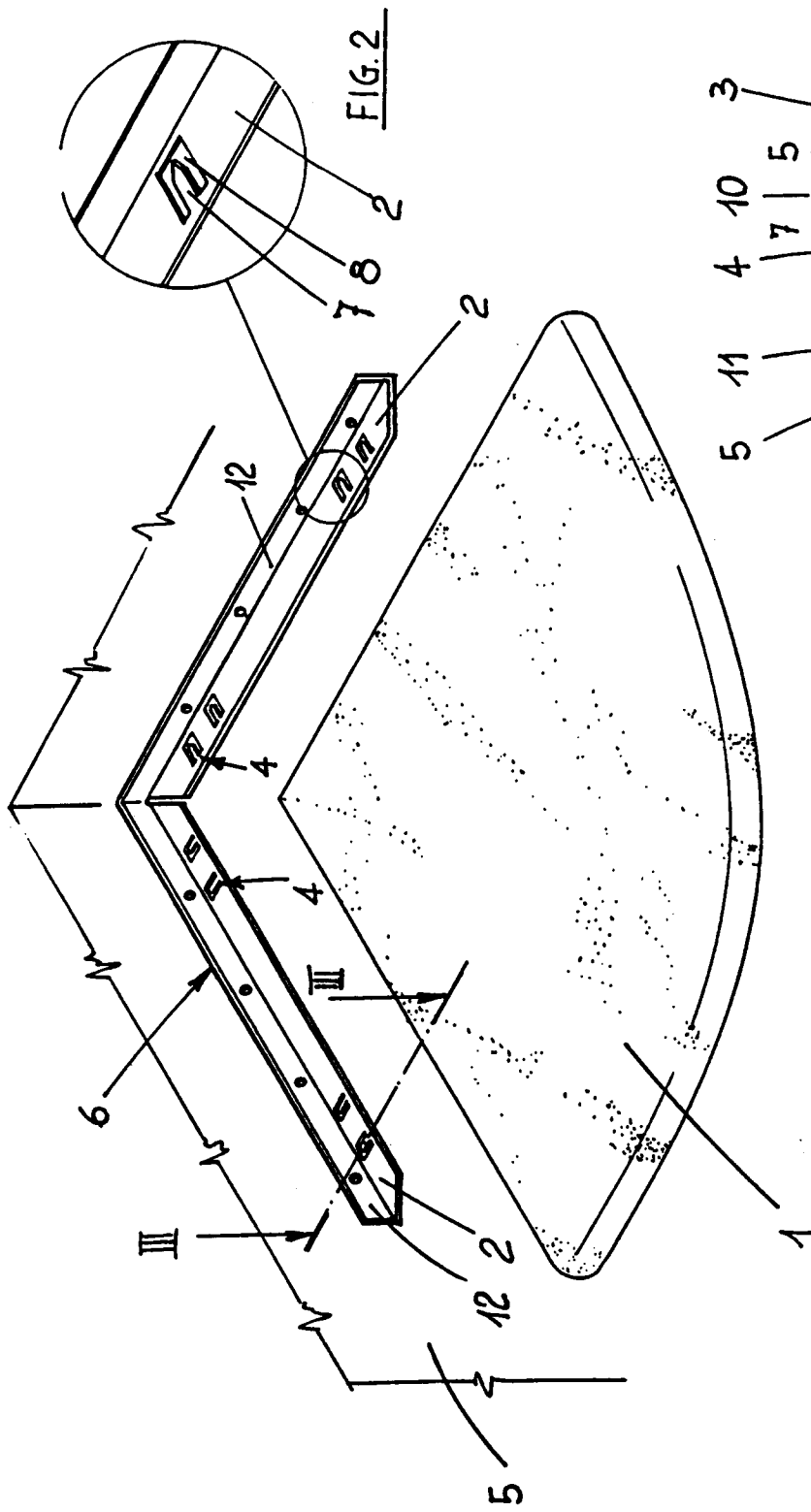

FIG. 2

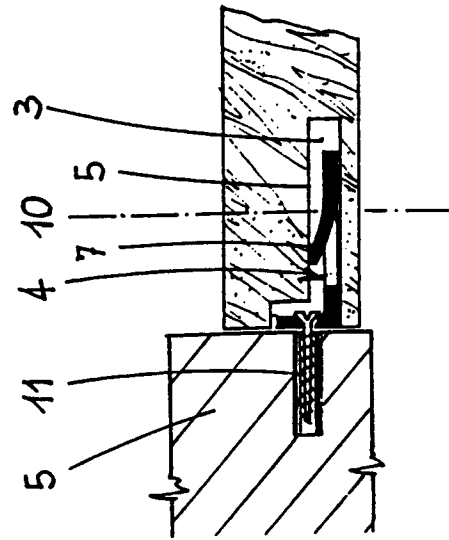

FIG. 3

FIG. 1

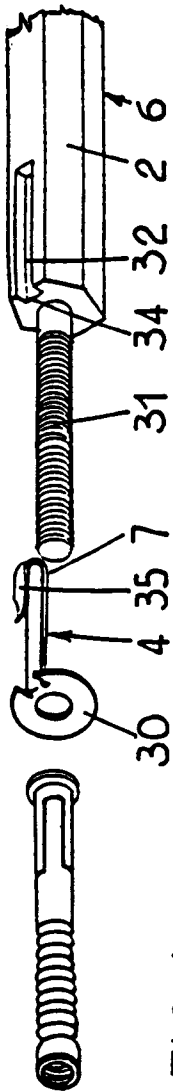
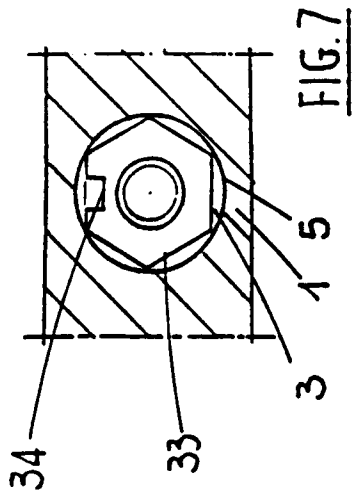

FIG. 4

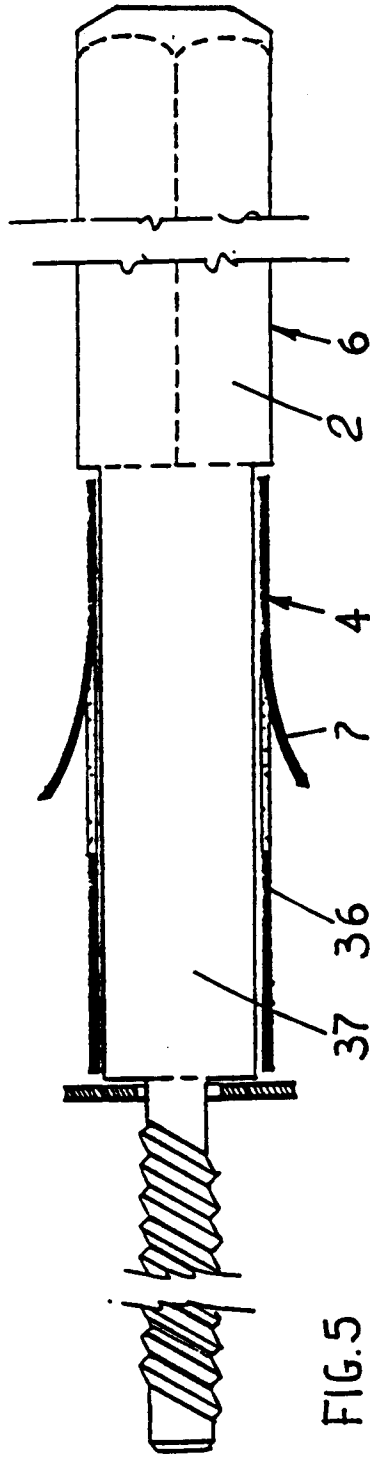

FIG. 5

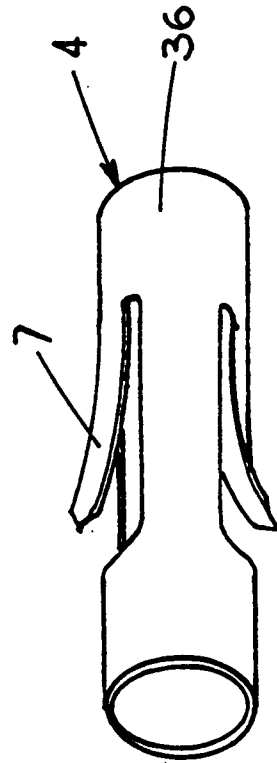

FIG. 6