

(No Model.)

5 Sheets—Sheet 1.

J. B. G. A. CANET.
RECOIL CHECK FOR ORDNANCE.

No. 522,508.

Patented July 3, 1894.

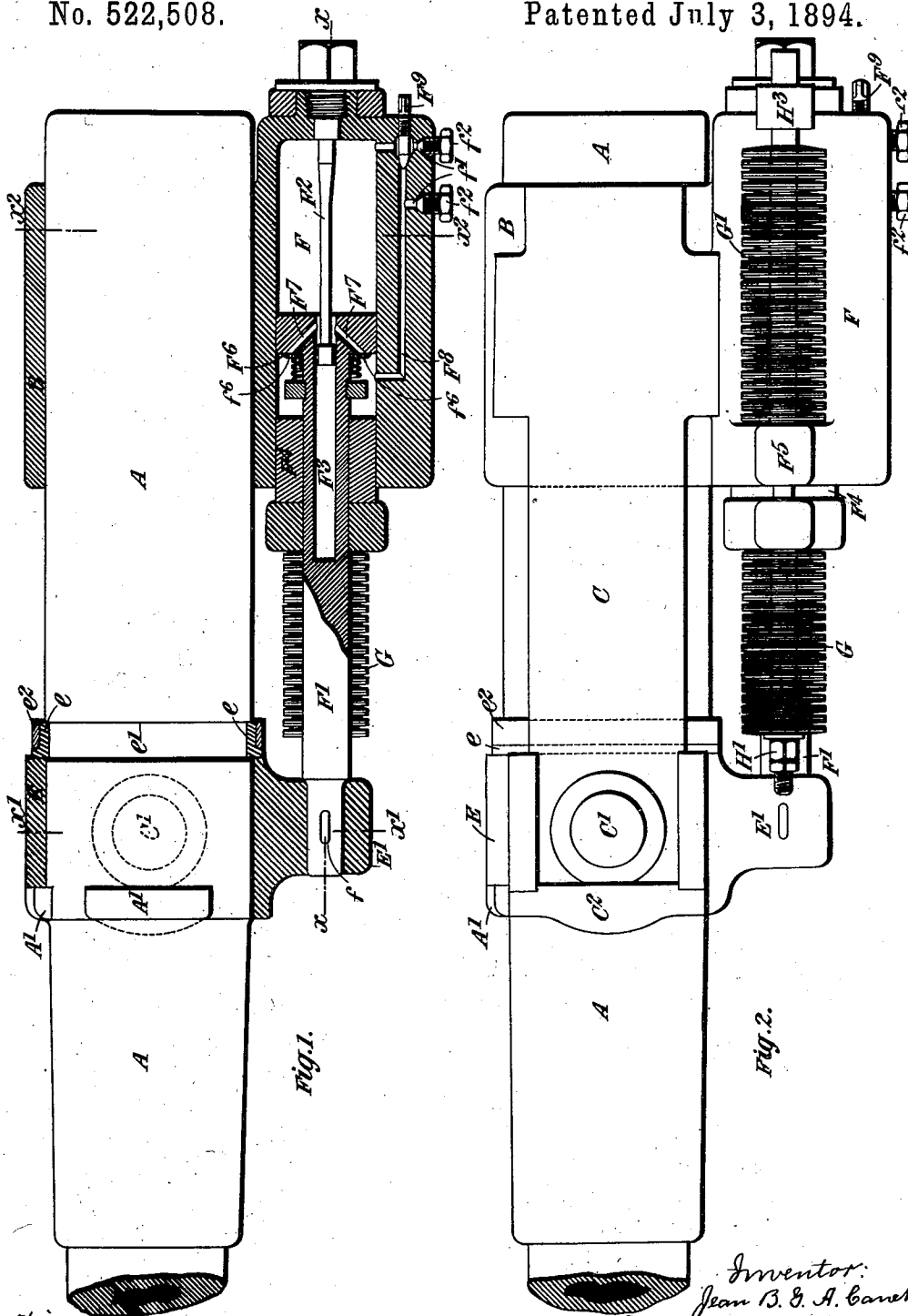

Fig. 1.

Fig. 2.

Witness:
G. W. Rea.
Robert Conant.

Inventor:
Jean B. G. A. Canet
By
James L. Torris.

(No Model.)

5 Sheets—Sheet 3.

J. B. G. A. CANET.
RECOIL CHECK FOR ORDNANCE.

No. 522,508.

Patented July 3, 1894.

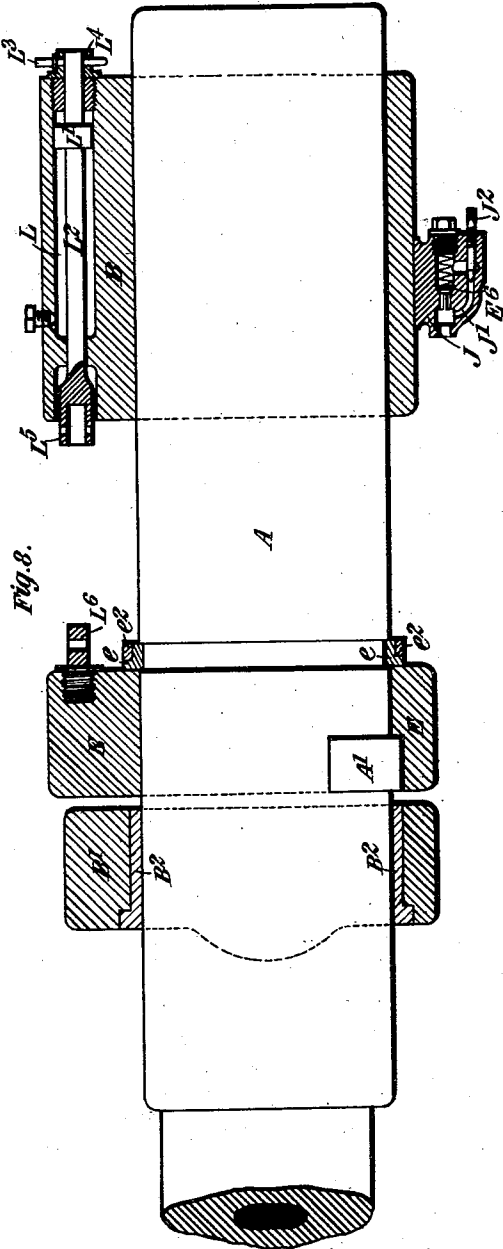
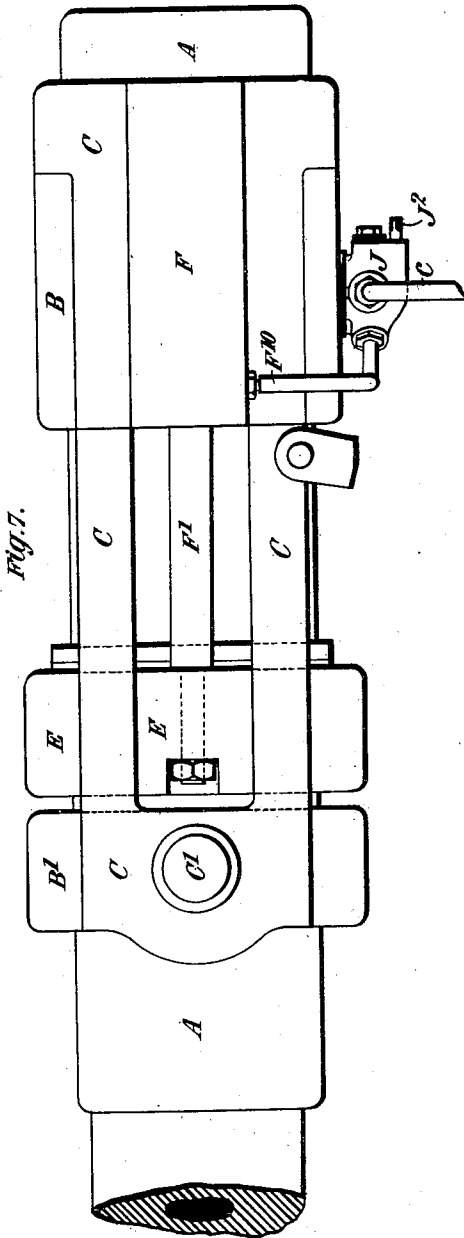

Witnesses:
 G. H. Rea.
 Wm. H. Conitt.

Inventor:
 Jean B. G. A. Canet
 By *J. J. Torrig.*
 Atty.

(No Model.)

5 Sheets—Sheet 5.

J. B. G. A. CANET.
RECOIL CHECK FOR ORDNANCE.

No. 522,508.

Patented July 3, 1894.

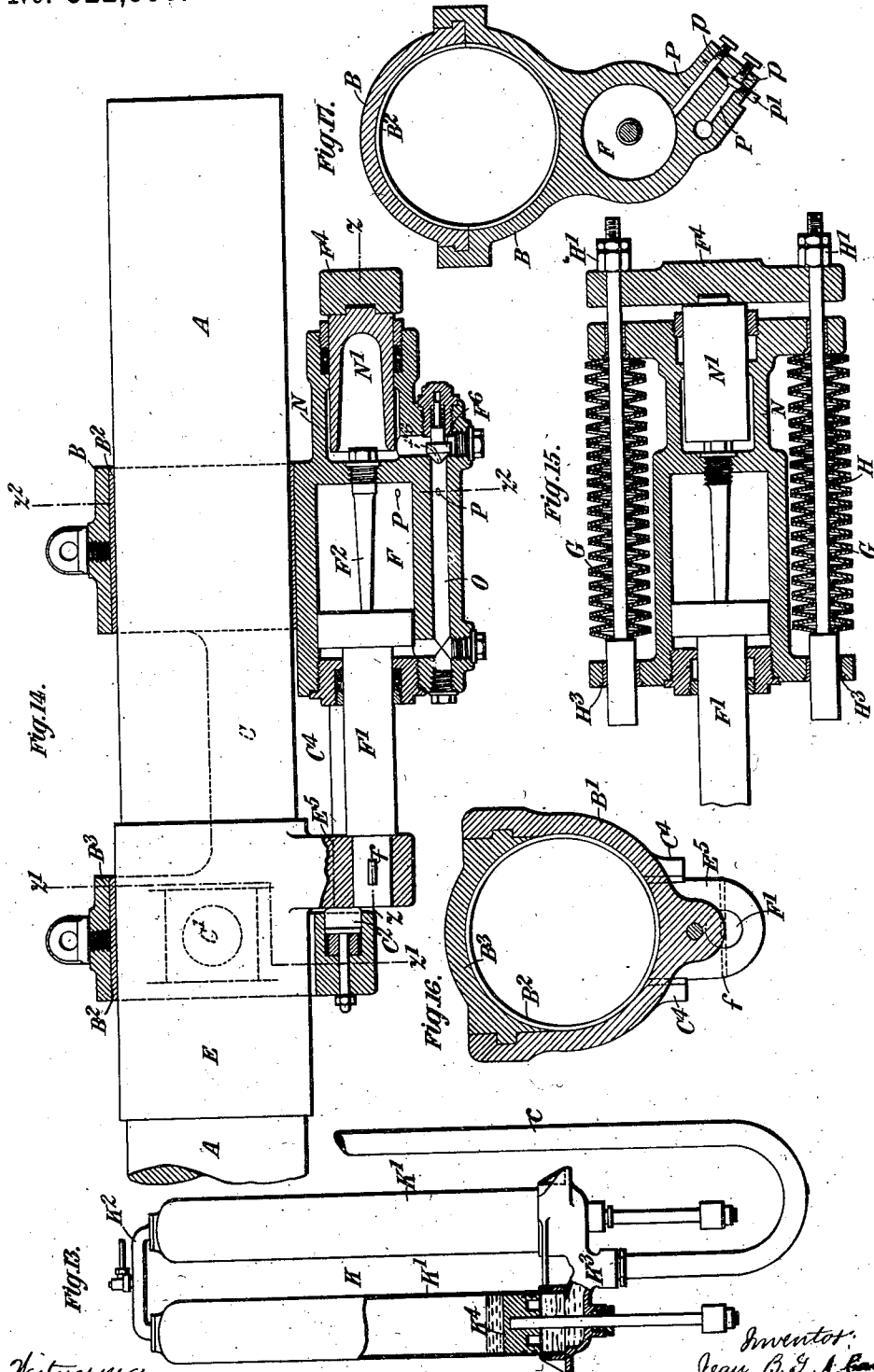

Witnesses:
D. W. Rea.
J. B. G. A. Canet.

Inventor:
Jean B. G. A. Canet
By *J. B. G. A. Canet*

UNITED STATES PATENT OFFICE.

JEAN BAPTISTE GUSTAVE ADOLPHE CANET, OF PARIS, FRANCE.

RECOIL-CHECK FOR ORDNANCE.

SPECIFICATION forming part of Letters Patent No. 522,508, dated July 3, 1894.

Application filed February 9, 1893. Serial No. 461,616. (No model.) Patented in France October 23, 1891, No. 216,937.

To all whom it may concern:

Be it known that I, JEAN BAPTISTE GUSTAVE ADOLPHE CANET, engineer, a citizen of the Republic of France, and a resident of Paris, France, have invented certain new and useful Improvements in and Relating to Gun-Mountings, (for which I have obtained a patent in France, No. 216,937, dated October 23, 1891,) of which the following is a specification, reference being had to the accompanying drawings.

This invention relates to gun mountings.

According to one construction, a sleeve in which the gun slides is formed on or attached to side frames or cheeks which are provided with trunnions, and in the said sleeve or attached thereto on the lower side thereof is provided a single hydraulic brake cylinder the piston rod of which is attached to a hoop or ring fixed on the gun. The said hoop or ring slides on the said side frames or cheeks during the recoil and running out of the gun. In a slightly modified form of construction, an additional sleeve through which the gun slides is formed on the side frames, and the brake cylinders are arranged at the sides of the gun.

The said invention also comprises the provision of subsidiary hydraulic cylinders for running the gun in and out when desired without firing, and also a novel recuperator in combination with the said sleeve, hoop or ring, and side frames.

In the accompanying drawings, Figure 1 is a vertical central section of the recuperator cylinder and sleeve, and hoop or ring, fixed to the gun, and showing also in side elevation a portion of the gun. Fig. 2 is a side elevation of the gun and mounting. Fig. 3 is a horizontal section on the line x, x Fig. 1. Fig. 4 is a half front elevation and half section on the line $x' x'$ Fig. 1. Fig. 5 is a half rear elevation and half section on the line $x^2 x^2$ Fig. 1. Fig. 6 is a half plan and half horizontal central section through the side frames and sleeve. Fig. 7 is a side elevation of a portion of the gun and slightly modified mounting constructed with brake cylinders at the sides of the gun. Fig. 8 is a longitudinal section of the mounting on the line $y^3 y^3$ Fig. 10, showing the gun in side elevation. Fig. 9 is a half plan and half horizontal central section of the said mounting. Fig. 10 is a half

rear elevation, and half section on the line $y y$ Fig. 9. Fig. 11 is a half front elevation and half section on the line $y' y'$ Fig. 9. Fig. 12 is a section on the line $y^2 y^2$ Fig. 9. Fig. 13 shows in side elevation partly in section an air or gas recuperator hereinafter described. Fig. 14 is a vertical central section of a mounting constructed according to a further modification of my invention, a portion of the gun being shown in side elevation. Fig. 15 is a horizontal section on the line $z z$, Fig. 14. Fig. 16 is a section on the line $z' z'$ Fig. 14. Fig. 17 is a section on the line $z^2 z^2$ Fig. 14.

Like letters denote corresponding parts throughout the drawings.

Referring to Figs. 1 to 6, A is the gun; B is a sleeve through which the gun can slide; C, C are side frames cast with or fixed to the sleeve B; C' C' are the trunnions formed on or fixed to the said side frames. D, Fig. 4, represents a portion of the carriage. E is a hoop or ring fixed to the gun and adapted to slide on the side frames C.

The sleeve B is made in one or several parts, and has cast on it or attached to it a hydraulic brake cylinder F below the gun. The piston rod F' of this cylinder is attached at its forward extremity by a collar f Figs. 1 and 4 to a projection E' on the hoop or ring E which is suitably secured to the exterior surface of the gun. In the construction shown in Figs. 1, 2 and 4 the hoop E is secured between projections A' formed on the gun and a hoop e constructed in halves and held by means of a ring e^2 in a recess e' formed in the gun. The projections A' constitute an interrupted collar on the gun. The hoop E is made with parts that project into and fit in the interruptions of the said collar and thus prevent the gun from turning in the hoop during the recoil. The said ring may be otherwise secured to the gun, for example, it may be placed while hot upon the gun and shrunk into its place thereon.

The side frames C, C serve as slides along which the hoop E, which is suitably recessed or grooved at $e^3 e^3$ Fig. 4 for the purpose, moves in its recoil and return. These side frames may or may not be braced by suitable trunnions and may be provided at the rear with stops or buffers to diminish the shock of recoil. A stop C² is fixed in the forward end

of each side frame or beam to limit the forward movement of the gun.

The hydraulic brake employed in this mounting, is furnished with a taper rod F^2 arranged to enter a central aperture F^3 in the piston for the purpose of regulating in a well known manner the area of the opening through which the liquid, displaced by the entrance into the cylinder of the piston rod F^1 , flows from one to the other side of the piston during the recoil. The liquid so displaced operates to force outward the loose head F^4 of the brake cylinder and thereby compresses a spring recuperator which serves to run out the gun at the end of the recoil. The recuperator consists of springs $G G' G'' G'''$, threaded upon rods H . The springs $G G'$ bear at their rear ends against the front of the head F^4 and at their forward ends against nuts H' screwed on the rods H . The springs $G'' G'''$ bear at their forward ends against a flange F^5 of the brake cylinder and at their rear ends against shoulders H^2 formed on the rods H . H^3 is a piece secured to the brake cylinder and forming a guide for the rear ends of the rods H .

A spring loaded valve F^6 which is mounted on the piston rod in front of the piston is raised from its seat by the pressure of the liquid flowing through orifices $F^7 F^7'$ from one to the other side of the piston during the recoil, and returns to its seat when the recoil is finished thus preventing the return of the liquid and maintaining the gun run in until a return thoroughfare is opened. This valve is in some cases perforated with small bypass orifices f^6 which allow of the slow return of the liquid and thus permit of the immediate commencement of the running out of the gun under the action of the recuperator while however moderating the speed of the running out.

F^8 Fig. 1 is a passage formed in the wall of the brake cylinder and communicating with the ends of the said cylinder on opposite sides of the piston. The area of opening of this passage can be regulated or the said passage can be closed entirely by means of an adjustable valve composed of a conical screw plug F^9 which is adapted to be screwed down upon a seat formed in the metal around the passage. By means of the adjustable screw-valve controlling the passage or thoroughfare F^8 the speed of running out can be regulated at will. Orifices $f^7 f^7'$ are made leading into the said passage F^8 on opposite sides of the screw-down valve F^9 into which orifices can be inserted the delivery pipe of a pump in case it should be necessary or desirable to use the same for running the gun in and out of battery. When a pump is not in use for the purpose the said orifices are closed by screw plugs $f^2 f^2'$. The action of the brake cylinder is well understood and need not be further explained here.

The mounting illustrated in Figs. 7 to 12 possesses the same general characteristics as

those above described, that is to say, it comprises the rear sleeve B to which are attached the side frames, beams, or checks C, C but there is a difference in respect of the arrangement of the brake cylinders F of which according to this part of the invention there are two placed one on each side of the sleeve B . In this mounting is also provided a forward sleeve B' in front of the fixed hoop or ring E . The trunnions are formed on the sleeve B' and project through and fit into openings C^3 provided in the side frames C . The sleeve B' is fitted with bushes $B^2 B^2$ which can be removed when worn and replaced by new ones. The side frames C are made with central openings which form guides for the hoop or ring E that is constructed to slide therein during the recoil and running out of the gun.

The construction of the brake cylinders is similar to that above described, but in this case the excess of liquid expelled by the entrance of the piston rods into the brake cylinders, passes out through pipes F^{10} which communicate with a valve box J containing a spring loaded non-return valve E^6 and raises said outlet valve and passes along a pipe c to a reservoir of compressed gas or air K Fig. 13 or into an air recuperator under spring pressure. The said air or gas recuperator is constructed of one or more hollow cylinders K' connected to each other at both ends by pipes K^2, K^3 and provided with pistons K^4 above which is the air or gas under pressure. The liquid enters the recuperator at the lower end below the said pistons which are covered by a slight depth of liquid. This arrangement effectively prevents the escape of the air or gas under pressure in the recuperator.

A passage J' Fig. 8 fitted with a plug or screw-down stopper J^2 is provided to permit the liquid to re-enter the brake cylinders and force the gun back into battery when required.

A special device is shown in Figs. 8 and 10 which allows the gun to be moved into and out of battery at will. This device comprises two or more hydraulic cylinders L mounted or formed on the sleeve B and provided with pistons L' the rods L^2 of which are normally or under ordinary conditions locked by pins L^3 passing through the same and through a piece L^4 fixed to the cylinder. The forward end L^5 of each piston rod is adapted to be coupled by a pin for example to a stud L^6 or the like fixed in the hoop or ring E . For running the gun in, it will be sufficient to disengage the pins L^3 , move the piston rods L^2 forward, connect the said rods to the studs L^6 and then inject liquid under pressure in front of the pistons L' of said hydraulic cylinders. The mounting shown in Figs. 14 to 17 is also characterized by substantially the same features in respect of the rear sleeve and the side frames or cheeks furnished with trunnions. The said frames or cheeks however in this modification are united at their forward ends by a piece B' cast on or otherwise attached thereto and forming with a cover or cap B^3 a sleeve

which embraces the gun. A bronze bush B² is preferably inserted in the said sleeve. This sleeve carries stops C² in the form of buffers to limit the outward run of the gun. The side frames C C are formed with projecting portions C⁴ C⁴ to serve as guides to a projection E⁵ formed on the hoop or ring E which is solid with the gun and to which projection is secured the end of the brake piston rod F⁷.

N is a recuperator cylinder placed behind the brake cylinder and fitted with a ram N' that presses against a head F⁴ that bears upon the recuperator springs G. The recuperator cylinder communicates with the brake cylinder by a passage O in which is placed a valve F⁶. The passage O permits the liquid expelled from the brake cylinder during recoil by the entrance therinto of the piston rod F⁷ to pass into the recuperator cylinder after raising the spring loaded valve F⁶. This valve is perforated with small orifices f⁶ to permit the liquid to return and run the gun out again. A thoroughfare P connects the passage O with the rear end of the brake cylinder. This thoroughfare is adapted to be closed by a screw down valve P'. Orifices p, p are made into this passage one on each side the valve P' adapted to receive the delivery pipe of a pump whereby the gun can be run in or out without firing.

What I claim is—

1. In a gun mounting, the combination of a sleeve through which the gun slides, a brake-cylinder and side beams or frames on the sleeve, trunnions on the side beams or frames, a hoop fixed to the gun, attached to the piston-rod of the brake-cylinder, and sliding on the said side beams or frames during the recoil and running out of the gun, substantially as described.

2. In a gun mounting, a hydraulic brake apparatus comprising a cylinder, a piston and hollow piston rod, apertures leading through to the front of the piston from the interior of the rod, a taper spindle secured to the cylinder end and adapted to enter the piston rod and control the area of the outlet opening for the liquid during recoil, a thoroughfare forming a communication between the ends of the brake cylinder on opposite sides of the piston, and an adjustable screw-valve operated from the exterior of the brake-cylinder for controlling said thoroughfare and regulating the speed of running out the gun, substantially as described, for the purpose specified.

3. In a gun mounting, a hydraulic brake apparatus comprising a cylinder, a piston and hollow piston rod, apertures leading through to the front of the piston from the interior of the rod, a spring loaded non-return valve for closing said apertures to allow the liquid to flow therethrough in one direction only, a ta-

per spindle secured to the cylinder end and adapted to enter the piston rod and control the area of the outlet opening for the liquid during recoil, a thoroughfare forming a communication between the ends of the brake cylinder on opposite sides of the piston, and an adjustable screw-valve operated from the exterior of the brake-cylinder for controlling said thoroughfare and regulating the speed of running out the gun, substantially as set forth for the purpose specified.

4. In a gun mounting, a hydraulic brake apparatus comprising a cylinder, a piston and hollow piston rod, apertures leading through to the front of the piston from the interior of the rod, a spring loaded perforated valve placed over said apertures, which valve allows the liquid to flow freely in one direction through the apertures, but only allows of a slow flow in the other direction through the perforations in the valve, a taper spindle secured to the cylinder end and adapted to enter the piston rod and control the area of the outlet opening for the liquid during recoil, a thoroughfare forming a communication between the ends of the brake cylinder on opposite sides of the piston, and an adjustable screw valve operated from the exterior of the brake-cylinder for controlling said thoroughfare and regulating the speed of running out the gun, substantially as set forth for the purpose specified.

5. The combination with a gun, of a hydraulic brake-cylinder, a thoroughfare formed in the cylinder to communicate with the opposite ends thereof, an adjustable screw-down valve operated from the exterior of the cylinder for closing said thoroughfare, and apertures leading into the thoroughfare at opposite sides of the adjustable screw-down valve for receiving the delivery pipe of a force pump to run the gun in or out when the adjustable screw-down valve is closed, substantially as described.

6. The combination with a gun, of a hydraulic brake-cylinder, a thoroughfare formed in the cylinder to communicate with the opposite ends thereof, an adjustable screw-down valve for closing said thoroughfare, and apertures leading into the thoroughfare at opposite sides of the adjustable screw-down valve and provided with non-return valves, said apertures being adapted to receive the delivery-pipe of a force pump to run the gun in or out when the adjustable screw-down valve is closed, substantially as described.

In witness whereof I have hereunto set my hand this 20th day of January, 1893.

JEAN BAPTISTE GUSTAVE ADOLPHE CANET

Witnesses:

ROBT. M. HOOPER,
CH. F. THIRION.