

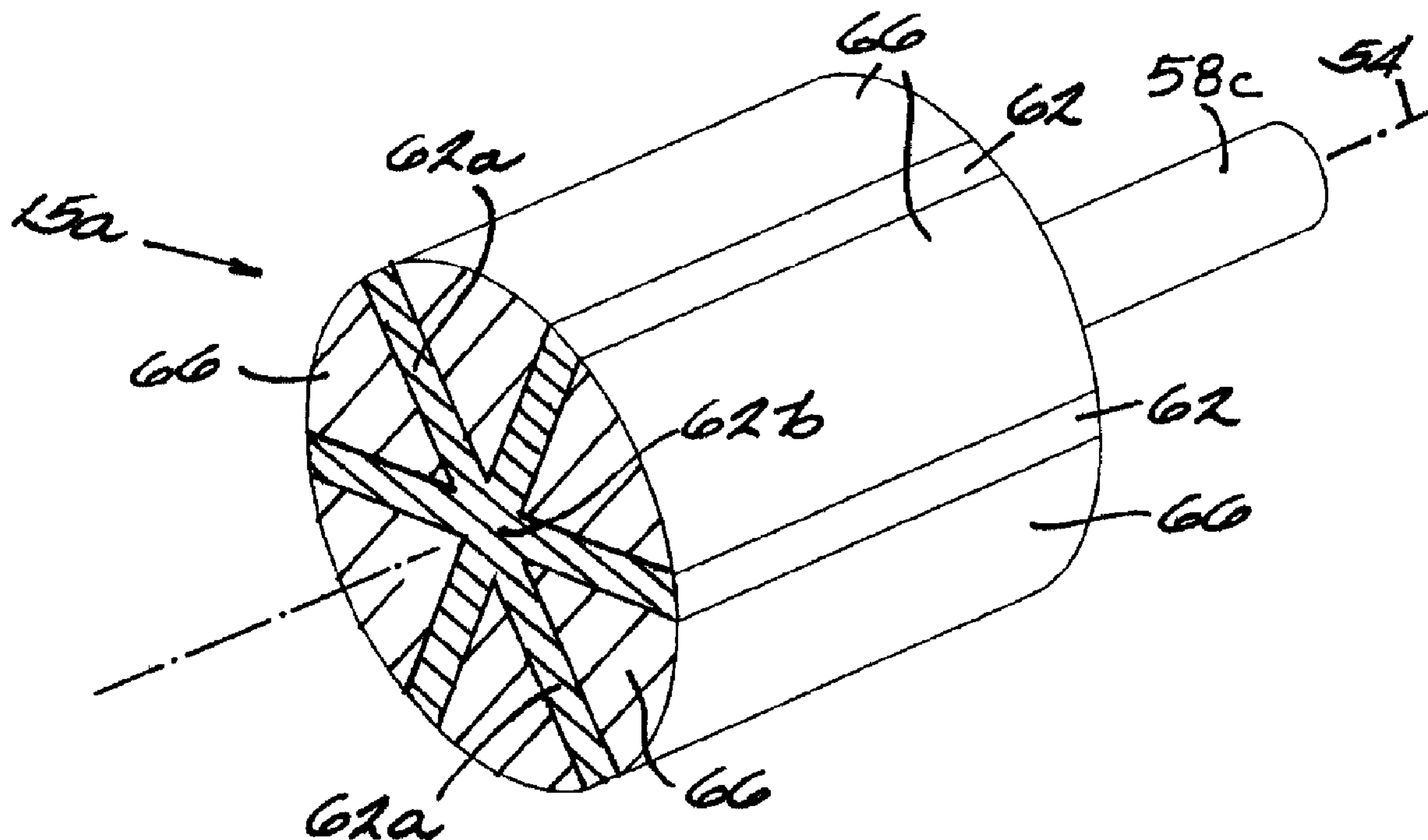

(22) Date de dépôt/Filing Date: 2004/10/22
 (41) Mise à la disp. pub./Open to Public Insp.: 2005/04/23
 (45) Date de délivrance/Issue Date: 2013/12/17
 (30) Priorité/Priority: 2003/10/23 (US10/691,818)

(51) Cl.Int./Int.Cl. *H02K 1/27* (2006.01),
H02K 15/03 (2006.01), *H02K 21/12* (2006.01)
 (72) Inventeurs/Inventors:
IONEL, DAN M., US;
HEIDEMAN, ROBERT J., US;
BARTOS, RONALD P., US
 (73) Propriétaire/Owner:
REGAL BELOIT AMERICA, INC., US
 (74) Agent: SMART & BIGGAR

(54) Titre : ROTOR A AIMANTS PERMANENTS ET A RAYONS POUR MACHINES ELECTRIQUES, ET METHODE DE FABRICATION CONNEXE
 (54) Title: SPOKE PERMANENT MAGNET ROTORS FOR ELECTRICAL MACHINES AND METHODS OF MANUFACTURING SAME



(57) Abrégé/Abstract:

A rotor assembly for an electric motor includes a spoke permanent magnet rotor and a shaft connected thereto. The spoke permanent magnet rotor has an axis of rotation, permanent magnet material, and ferro-magnetic material. The permanent magnet material extends outwardly relative to the axis of rotation to form a plurality of outwardly extending spoke portions of permanent magnet material. The ferro-magnetic material is positioned adjacent to the outwardly extending spoke portions of permanent magnet material. The shaft supports the spoke permanent magnet rotor for rotation about the axis of rotation. The permanent magnet material may circumferentially surround the axis of rotation to form a center portion of permanent magnet material. Further, the axis of rotation may pass through the permanent magnet material. The spoke permanent magnet rotor may be formed using a compaction process and/or an injection molding process.



ABSTRACT

A rotor assembly for an electric motor includes a spoke permanent magnet rotor and a shaft connected thereto. The spoke permanent magnet rotor has an axis of rotation, permanent magnet material, and ferro-magnetic material. The permanent magnet material extends outwardly relative to the axis of rotation to form a plurality of outwardly extending spoke portions of permanent magnet material. The ferro-magnetic material is positioned adjacent to the outwardly extending spoke portions of permanent magnet material. The shaft supports the spoke permanent magnet rotor for rotation about the axis of rotation. The permanent magnet material may circumferentially surround the axis of rotation to form a center portion of permanent magnet material. Further, the axis of rotation may pass through the permanent magnet material. The spoke permanent magnet rotor may be formed using a compaction process and/or an injection molding process.

SPOKE PERMANENT MAGNET ROTORS FOR ELECTRICAL MACHINES AND METHODS OF MANUFACTURING SAME

BACKGROUND OF THE INVENTION

5

The present invention relates to electric machines, and more particularly to spoke permanent magnet rotors for use in electric motors.

Spoke permanent magnet rotors generally include a plurality of permanent magnets radially arranged around a shaft. The permanent magnets are magnetized tangentially,
10 through the thickness of the permanent magnet, either before or after insertion into the rotor. Magnetic flux generated by the permanent magnets is collected and concentrated by ferro-magnetic pole pieces. Often, the pole pieces are utilized to retain the permanent magnets.

Some examples of spoke permanent magnet rotors are disclosed in U.S. Patent Nos. 4,631,807; 5,140,211; 5,157,297; 5,200,662; and 5,463,262.

15 Spoke permanent magnet rotors have a natural flux concentration capability because two circumferentially adjacent permanent magnets contribute to the air-gap flux for each rotor pole. This flux concentration capability allows the air-gap magnetic flux density to be higher than the flux density of each permanent magnet that contributes to the air-gap magnetic flux density. Accordingly, electric motors that include spoke permanent magnet
20 rotors often have a high specific torque output. This translates to a smaller overall weight and lower material cost for a given rating of electric motor. Further, based on the radial arrangement of the permanent magnets, the permanent magnets are less likely to become demagnetized. Therefore, rated operation close to the maximum energy product is possible without the risk of demagnetization of the permanent magnets under fault conditions.
25 Operation at a maximum energy product ensures optimum utilization of the permanent magnets. This translates to lower material costs for a given rating of electric motor.

Despite the above-mentioned advantages of spoke permanent magnet rotors, only a relatively small number of spoke permanent magnet rotors are produced worldwide. One limiting factor for high volume production is the complicated construction required to reduce
30 or eliminate the permanent magnet flux leakage from the radially inward portions of the permanent magnets towards the magnetic shaft. Another limiting factor is the complicated construction required to retain the permanent magnets and the pole pieces in the rotor during normal operation of the electric motor. A new spoke type permanent magnet rotor that provides enhanced performance and reduced costs would be welcomed by those in the art.

67363-1348

- 2 -

SUMMARY OF THE INVENTION

According to one aspect of the present invention, there is provided a rotor assembly for an electric motor, the rotor assembly comprising: a spoke permanent magnet rotor having an axis of rotation, permanent magnet material circumferentially surrounding the axis of rotation to form a circumferentially surrounding portion of permanent magnet material and extending outwardly relative to the axis of rotation to form a plurality of outwardly extending portions of permanent magnet material, the circumferential portion defining a first interface surface, and ferro-magnetic material positioned adjacent to the outwardly extending portions of permanent magnet material and including an outer surface and a second interface surface formed inward of the outer surface that engages the first interface surface, the first interface surface and second interface surface arranged to inhibit outward radial motion of the ferro-magnetic material; and a shaft supporting the spoke permanent magnet rotor for rotation about the axis of rotation.

According to another aspect of the present invention, there is provided a rotor assembly for an electric motor, the rotor assembly comprising: a permanent magnet rotor having an axis of rotation, a center portion of permanent magnet material, a plurality of angularly spaced spoke portions of permanent magnet material extending outwardly from the center portion of permanent magnet material, and ferro-magnetic material positioned between the angularly spaced spoke portions of permanent magnet material; and a shaft supporting the permanent magnet rotor for rotation about the axis of rotation, wherein the ferro-magnetic material forms a plurality of pole pieces, and wherein the permanent magnet material includes plastic bonded permanent magnet material injection molded around the pole pieces, wherein the permanent magnet material and the ferro-magnetic material have an interface therebetween that prevents the ferro-magnetic material adjacent to the interface from moving outwardly during rotation of the spoke permanent magnet rotor about the axis of rotation.

According to still another aspect of the present invention, there is provided a rotor assembly for an electric motor, the rotor assembly comprising: a spoke permanent magnet rotor having an axis of rotation, permanent magnet material extending outwardly

67363-1348

- 2a -

relative to the axis of rotation to form a plurality of outwardly extending spoke portions of permanent magnet material, at least one of the plurality of spoke portions defining a first interface surface, the permanent magnet material including permanent magnet powder compacted using an electromagnetic compaction process, and ferro-magnetic material
5 positioned adjacent to the outwardly extending spoke portions of permanent magnet material and including an outer surface and a second interface surface formed inward of the outer surface that engages the first interface surface, the first interface surface and second interface surface arranged to inhibit outward radial motion of the ferro-magnetic material; and a shaft supporting the spoke permanent magnet rotor for rotation about the axis of rotation.

10 According to yet another aspect of the present invention, there is provided a method of constructing a rotor assembly for an electric motor, the method comprising: compacting permanent magnet powder and ferro-magnetic powder using an electromagnetic compaction process to form a spoke permanent magnet rotor, the compacted permanent magnet powder forming a center portion of permanent magnet material and a plurality of
15 spoke portions of permanent magnet material extending outwardly from the center portion of permanent magnet material, wherein at least one of the center portion and one of the plurality of spoke portions defines a first interface surface, and the compacted ferro-magnetic powder forming a plurality of pole pieces, each pole piece being positioned between a respective set of circumferentially adjacent spoke portions of permanent magnet material and including an
20 outer surface and a second interface surface formed inward of the outer surface; engaging the first interface surface and the second interface surface to inhibit outward radial motion of the ferro-magnetic pole pieces; and supporting the spoke permanent magnet rotor on a shaft for rotation about an axis of rotation.

 According to a further aspect of the present invention, there is provided a rotor
25 assembly for an electric motor, the assembly comprising: a spoke permanent magnet rotor having an axis of rotation, permanent magnet material extending outwardly relative to the axis of rotation to form a plurality of outwardly extending spoke portions of permanent magnet material, at least one of the plurality of spoke portions defining a first interface surface, ferro-magnetic material forming a plurality of pole pieces, each pole piece being positioned

67363-1348

- 2b -

between a set of circumferentially adjacent outwardly extending spoke portions of permanent magnet material, at least one of the pole pieces including a second interface surface that engages the first interface surface to inhibit outward radial motion of the at least one pole piece, the permanent magnet material including injection molded plastic bonded permanent magnet material; and a shaft supporting the spoke permanent magnet rotor for rotation about the axis of rotation.

According to yet a further aspect of the present invention, there is provided a method of constructing a rotor assembly for an electric motor, the method comprising: providing a plurality of ferro-magnetic pole pieces; injection molding plastic bonded permanent magnet material to form a spoke permanent magnet rotor, the injection molded plastic bonded permanent magnet material forming a center portion of permanent magnet material and a plurality of spoke portions of permanent magnet material extending outwardly from the center portion of permanent magnet material, and each pole piece being positioned between a respective set of circumferentially adjacent spoke portions of permanent magnet material; interlocking the permanent magnet material and the ferro-magnetic pole pieces to inhibit radially outward movement of the ferro-magnetic pole pieces with respect to the permanent magnet material; and supporting the spoke permanent magnet rotor on a shaft for rotation about an axis of rotation.

Some embodiments may provide spoke permanent magnet rotors that provide enhanced performance and reduced costs.

In one embodiment, there is provided a rotor assembly for an electric motor. The rotor assembly includes a spoke permanent magnet rotor and a shaft connected thereto. The spoke permanent magnet rotor has an axis of rotation, permanent magnet material, and ferro-magnetic material. The permanent magnet material circumferentially surrounds the axis of rotation to form a circumferentially surrounding portion of permanent magnet material. The permanent magnet material also extends outwardly relative to the axis of rotation to form a plurality of outwardly extending portions of permanent magnet material. The ferro-magnetic material is positioned adjacent to the outwardly extending portions of permanent

67363-1348

- 2c -

magnet material. The shaft supports the spoke permanent magnet rotor for rotation about the axis of rotation.

In another embodiment, there is provided a rotor assembly for an electric motor. The rotor assembly includes a permanent magnet rotor and a shaft connected thereto.

5 The permanent magnet rotor has an axis of rotation, a center portion of permanent magnet material, a plurality of angularly spaced spoke portions of permanent magnet material that extend outwardly from the center portion of permanent magnet material, and ferro-magnetic material positioned between the angularly spaced spoke portions of permanent magnet material. The shaft supports the spoke permanent magnet rotor for rotation about the axis of
10 rotation.

In another embodiment, there is provided a rotor assembly for an electric motor. The rotor assembly includes a spoke permanent magnet rotor and a shaft connected thereto. The spoke permanent magnet rotor has an axis of rotation, permanent magnet material, and ferro-magnetic material. The permanent magnet material extends outwardly
15 relative to the axis of rotation to form a plurality of outwardly extending spoke portions of permanent magnet material. The permanent magnet material includes permanent magnet powder compacted using an electromagnetic compaction process. The ferro-magnetic material is positioned adjacent to the outwardly extending spoke portions of permanent magnet material. The shaft supports the spoke permanent magnet rotor for rotation about the
20 axis of rotation.

In another embodiment, there is provided a method of constructing a rotor assembly for an electric motor. The method includes compacting permanent magnet powder and ferro-magnetic powder using an electromagnetic compaction process to form a spoke permanent magnet rotor, and supporting the spoke permanent magnet rotor on a shaft for

67363-1348

-3-

rotation about an axis of rotation. The compacted permanent magnet powder forms a center portion of permanent magnet material and a plurality of spoke portions of permanent magnet material extending outwardly from the center portion of permanent magnet material. The compacted ferro-magnetic powder forms a plurality of pole pieces. Each pole piece is
5 positioned between a respective set of circumferentially adjacent spoke portions of permanent magnet material.

In another embodiment, there is provided a rotor assembly for an electric motor. The rotor assembly includes a spoke permanent magnet rotor and a shaft connected thereto. The spoke permanent magnet rotor has an axis of rotation, permanent magnet material, and
10 ferro-magnetic material. The permanent magnet material extends outwardly relative to the axis of rotation to form a plurality of outwardly extending spoke portions of permanent magnet material. The ferro-magnetic material forms a plurality of pole pieces. Each pole piece is positioned between a set of circumferentially adjacent outwardly extending spoke portions of permanent magnet material. The permanent magnet material includes injection
15 molded plastic bonded permanent magnet material. The shaft supports the spoke permanent magnet rotor for rotation about the axis of rotation.

In yet another embodiment, there is provided a method of constructing a rotor assembly for an electric motor. The method includes providing ferro-magnetic pole pieces, injection molding plastic bonded permanent magnet material to form a spoke permanent
20 magnet rotor, and supporting the spoke permanent magnet rotor on a shaft for rotation about an axis of rotation. The injection molded plastic bonded permanent magnet material forms a center portion of permanent magnet material and a plurality of spoke portions of permanent magnet material extending outwardly from the center portion of permanent magnet material. Each pole piece is positioned between a respective set of circumferentially adjacent spoke
25 portions of permanent magnet material.

Further objects of the present invention together with the organization and manner of operation thereof, will become apparent from the following detailed description of the invention when taken in conjunction with the accompanying drawings wherein like elements have like numerals throughout the drawings.

30

BRIEF DESCRIPTION OF THE DRAWINGS

The present invention is further described with reference to the accompanying drawings, which show embodiments of the present invention. However, it should be noted that the invention as disclosed in the accompanying drawings is illustrated by way of example

67363-1348

-4-

only. The various elements and combinations of elements described below and illustrated in the drawings can be arranged and organized differently to result in embodiments which are still within the spirit and scope of the present invention. Also, it is understood that the phraseology and terminology used herein is for the purpose of description and should not be regarded as limiting. The use of "including," "comprising," or "having" and variations thereof herein is meant to encompass the items listed thereafter and equivalents thereof as well as additional items. Unless specified or limited otherwise, the terms "mounted," "connected," "supported," and "coupled" are used broadly and encompass both direct and indirect mountings, connections, supports, and couplings. Further, "connected" and "coupled" are not restricted to physical or mechanical connections or couplings.

FIG. 1 is an schematic axial view of an electric motor including a spoke permanent magnet rotor assembly.

FIG. 2 illustrates a perspective view of a spoke permanent magnet rotor assembly according to a first construction.

FIG. 3 illustrates a sectional perspective view of the spoke permanent magnet rotor assembly illustrated in FIG. 2.

FIG. 4 illustrates a sectional perspective view of a spoke permanent magnet rotor assembly according to a second construction.

FIG. 5 illustrates a sectional perspective view of a spoke permanent magnet rotor assembly according to a third construction.

FIG. 6 illustrates a sectional perspective view of a spoke permanent magnet rotor assembly according to a fourth construction.

FIG. 7 illustrates a sectional perspective view of a spoke permanent magnet rotor assembly according to a fifth construction.

DETAILED DESCRIPTION

An electric motor 10 including a spoke permanent magnet rotor assembly 15 is schematically illustrated in FIG. 1. The specific motor embodiment shown is for exemplary purposes. The invention described herein may be used in any type of electric motor having a spoke permanent magnet rotor.

As illustrated in FIG. 1, the motor 10 includes a motor housing 20 with first and second ends 24 and 28. The motor housing 20 may include a plurality of pieces to accommodate assembly and maintenance. Mounted within each of the first and second ends 24 and 28 of the housing 20 is a respective bearing assembly 32. A stator 40 is mounted

within the housing 20. For simplicity, the stator end-windings are not represented in FIG. 1. The spoke permanent magnet rotor assembly 15 is rotationally supported within the housing 20, such that the rotor assembly 50 may turn freely relative to the stator 40.

The rotor assembly 15 includes a spoke permanent magnet rotor 50 having an axis of rotation 54, and a shaft 58 to support the spoke permanent magnet rotor 50 for rotation about the axis of rotation 54. As discussed further below, the shaft 58 may include a through-shaft, a through-shaft assembly, stub shafts, stub shaft assemblies, and the like. A first construction of the spoke permanent magnet rotor assembly 15 is illustrated in FIGS. 2 and 3 as spoke permanent magnet rotor assembly 15a. The rotor assembly 15a includes a spoke permanent magnet rotor 50a. A second construction of the spoke permanent magnet rotor assembly 15 is illustrated in FIG. 4 as spoke permanent magnet rotor assembly 15b. The rotor assembly 15b includes a spoke permanent magnet rotor 50b. A third construction of the spoke permanent magnet rotor assembly 15 is illustrated in FIG. 5 as spoke permanent magnet rotor assembly 15c. The rotor assembly 15c includes a spoke permanent magnet rotor 50c. A fourth construction of the spoke permanent magnet rotor assembly 15 is illustrated in FIG. 6 as spoke permanent magnet rotor assembly 15d. The rotor assembly 15d includes a spoke permanent magnet rotor 50d. A fifth construction of the spoke permanent magnet rotor assembly 15 is illustrated in FIG. 7 as spoke permanent magnet rotor assembly 15e. The rotor assembly 15e includes a spoke permanent magnet rotor 50e. Like parts of each construction of the rotor assembly 15 are described and illustrated using like reference numerals.

Each spoke permanent magnet rotor 50 includes permanent magnet material 62 and ferro-magnetic material 66. The permanent magnet material 62 extends outwardly relative to the axis of rotation 54 to form a plurality of angularly spaced, outwardly extending spoke portions of permanent magnet material 62a. In each of the illustrated constructions, the outwardly extending spoke portions of permanent magnet material 62a extend radially outward relative to the axis of rotation 54 to form a plurality of angularly spaced, radially extending spoke portions of permanent magnet material 62a. In other constructions, the outwardly extending spoke portions 62a may not extend radially outward relative to the axis of rotation 54. Further, in each of the illustrated constructions, the radially extending spoke portions of permanent magnet material 62a extend to the perimeter of the spoke permanent magnet rotor 50, and are therefore visible along the generally cylindrical exterior surface of the rotor 50. In other constructions, the radially extending spoke portions 62a may not extend to the perimeter of the rotor 54.

For the spoke permanent magnet rotors 50a, 50b, 50c, and 50d, the permanent magnet material 62 also circumferentially surrounds the axis of rotation 58 (i.e., the permanent magnet material 62 surrounds or encircles the entire axis of rotation 58 at some radial position) to form a circumferentially surrounding portion of permanent magnet material 62b.

5 Each circumferentially surrounding portion of permanent magnet material 62b extends from a first radial position to a second radial position spaced from and outward of the first radial position. The distance between the first and second radial positions, and thus the thickness of the circumferentially surrounding portion of permanent magnet material 62b, may vary.

10 For the spoke permanent magnet rotors 15a, 15b, and 15c, the first radial position is positioned substantially adjacent the axis of rotation 54, and the second radial position is positioned substantially adjacent the radially innermost portion of ferro-magnetic material 66. In constructions where the first radial position is positioned substantially adjacent the axis of rotation 54, the axis of rotation 54 often extends through the permanent magnet material 62 (i.e., the permanent magnet material 62 extends along at least a portion of the axis of rotation)

15 to form a center portion of permanent magnet material that is solid. The solid center portion of permanent magnet material includes the circumferentially surrounding portion of permanent magnet material 62b and the portion of permanent magnet material through which the axis of rotation 54 extends.

For the spoke permanent magnet rotor 15d and with respect to the rotor cross section,

20 the first radial position is spaced radially from the axis of rotation 54, and the second radial position is positioned substantially adjacent the radially inner most portion of ferro-magnetic material 66. In constructions where the first radial position is spaced from the axis of rotation 54, the first radial position is often positioned substantially adjacent the radially outermost portion of a center hole 70. The center hole 70 may be formed or machined in the rotor 50.

25 Further, the center hole 70 may be of any shape and size.

The center hole 70 may accommodate a respective shaft 58 (e.g., a through-shaft, a through-shaft assembly). A center portion of permanent magnet material may include the circumferentially surrounding portion of permanent magnet material 62b that surrounds the shaft 58. The center hole 70 may remain open to form a hollow portion along the axis of

30 rotation 54. In some embodiments, the axis of rotation 54 extends through the hollow portion. A center portion of permanent magnet material may include the circumferentially surrounding portion of permanent magnet material 62b and the hollow portion. The center hole 70 may be at least partially filled with either a non-magnetic material and/or another material to form a center core or core portion 74 (FIG. 6). A center portion of permanent

67363-1348

- 7 -

magnet material may include the circumferentially surrounding portion of permanent magnet material 62b that surrounds the center core 74.

The ferro-magnetic material 66 forms pole pieces. Generally, a pole piece is positioned between each set of circumferentially adjacent radially extending portions of permanent magnet material 62. The pole pieces collect and concentrate the magnetic flux generated by the magnetized permanent magnet material 62. In some construction, the pole pieces each include at least one interface surface that prevents movement between the pole piece and the adjacent permanent magnet material 62. Such construction enhances rotor structure integrity and mechanical strength. For example, the pole pieces of the spoke permanent magnet rotors 15b and 15c each include an interface surface.

With reference to FIG. 4, the interface surfaces of the pole pieces of the spoke permanent magnet rotor 15b each include a recess interface surface that forms a recess 80 having a main portion 80a and a throat portion 80b. The throat portion 80b is narrower than the main portion 80a. The permanent magnet material 62 includes corresponding interface surfaces that engage the recess interface surfaces of the pole pieces.

With reference to FIG. 5, the interface surfaces of the pole pieces of the spoke permanent magnet rotor 15c each include a dovetail interface surface that forms a dovetail 84 having a main portion 84a and a throat portion 84b. The throat portion 84b is narrower than the main portion 84a. The permanent magnet material 62 includes corresponding interface surfaces that engage the dovetail interface surfaces of the pole pieces. The interface surfaces of the pole pieces and/or the permanent magnet material may be alternatively sized and/or shaped in other constructions.

In some constructions (e.g., the spoke permanent magnet rotors 50a, 50d, and 50e), the rotor 50 may be formed from ferro-magnetic and permanent magnet powders that are compacted using a dynamic magnetic compaction process, or a similar type of electromagnetic compaction process. The dynamic magnetic compaction process is generally explained in U.S. Patent Nos. 5,405,574; 5,611,139; 5,611,230; 5,689,797; 6,273,963; 6,432,554; and 6,524,526; and U.S. Patent Application Publication No. 2002/0192103 and 2003/0051614; each of which are assigned to LAP Research of Dayton, Ohio.

In one embodiment of the dynamic magnetic compaction process, the ferro-magnetic and permanent magnet powders are loaded into an electrically conductive container (e.g., a container constructed of copper, steel, or aluminum) for simultaneous compaction. Specific reference is made to the above referenced U.S. Patent Application Publication No. 2002/0192103 which discloses a system and method for loading

a plurality of powder materials in to an electromagnetic compaction press for simultaneous compaction. In other embodiments of the dynamic magnetic compaction process, the ferro-magnetic powder or the permanent magnet power is loaded into an electrically conductive container for individual compaction. For each embodiment, the loaded container is placed at the center of an electromagnetic coil. A current pulse is put through the coil, creating high magnetic pressure radially around the container. As the container collapses around the powder, the powder is compressed into a high density, near-net shape rotor 50. Dies can also be placed within the container to form rotor features around the dies (e.g., a center hole, interface surfaces, and the like).

10 Electromagnetic compaction can be done at a variety of temperatures (e.g., room temperature, temperatures elevate above room temperature) and in a variety of environments (e.g., air, special atmospheres). After the rotor 50 is compacted, it can be sintered to improve its strength. For some applications, however, the rotors 50 are strong enough that the sintering step can be omitted.

15 In other constructions (e.g., the spoke permanent magnet rotors 50b and 50c), the rotor 50 may be formed of ferro-magnetic pole pieces and plastic bonded permanent magnet material injection molded around the pole pieces using an injection molding process. The ferro-magnetic pole pieces may be formed of ferro-magnetic laminations (e.g., interlocking ferro-magnetic laminations, bonded together ferro-magnetic laminations, ferro-magnetic laminations secured using fasteners extending there through, and the like), solid ferro-magnetic material (e.g., solid steel), and/or composite ferro-magnetic materials. The ferro-magnetic pole pieces are placed in a fixture and the plastic bonded permanent magnet material (e.g., NdFeB, ferrite, and the like) is injection molded into the voids left in the fixture to produce a rotor 50. Utilization of pole pieces having interface surfaces allows for the creation of corresponding interface surfaces in the plastic bonded permanent magnet material during the injection molding process. Engagement between the interface surfaces of the pole pieces and the plastic bonded permanent magnet material increases the structural integrity of the rotor 50. In other embodiments, the plastic bonded permanent magnet material may be molded in a fixture to produce structure to which ferro-magnetic pole pieces are later added.

30 In other constructions, the rotor 50 may be formed of blocks of permanent magnet material and soft magnetic particles of ferro-magnetic material (e.g., iron particles coated with a non-magnetic binder such as a thermoplastic or resin so that the iron particles are space separated and bound together by the non-magnetic binder) molded around the pieces of

67363-1348

- 9 -

permanent magnet material. In one embodiment, the pieces of permanent magnet material are placed in a fixture and the soft magnetic particles of ferro-magnetic material is molded into the voids of the fixture to produce a rotor 50. In other embodiments, the soft magnetic particles of ferro-magnetic material may be molded in a fixture to produce a rotor core to which pieces of permanent magnet material are later added. A molding process that utilizes soft magnetic particles of ferro-magnetic material is disclosed in U.S. Patent No. 5,536,985, which is assigned to General Motors Corporation of Detroit, Michigan.

In yet other constructions, the rotor 50 may be formed using other methods, or a combination of any number of the above described methods (e.g., the pole pieces may be formed of ferro-magnetic powder using an electromagnetic compaction process or a mechanical pressing and sintering process, and the permanent magnet material 62 then injection molded around the pole pieces).

The spoke permanent magnet rotor 50 may be attached to the shaft 58 during and/or after construction of the rotor 50. In some embodiments, the shaft 58 includes an axis of rotation that is collinear with the axis of rotation of the spoke permanent rotor 50. In some construction, a magnetic or non-magnetic through-shaft extends through the center hole 70 of a respective rotor 50. To reduce or eliminate leakage magnetic flux from the magnetized permanent magnet material 62 toward a magnetic shaft, a sleeve of non-magnetic material may be positioned radially inward of the permanent magnet material 62 and radially outward of the magnetic shaft. In one construction, as illustrated in FIG. 7, a through-shaft assembly including a magnetic shaft 58a and a non-magnetic sleeve 58b surrounding at least a portion of the magnetic shaft 58a is utilized. In other constructions, at least a portion of a circumferentially surrounding portion of permanent magnet material 62b may remain unmagnetized to act as a non-magnetic material.

In other constructions, magnetic or non-magnetic stub shafts are connected directly to the rotor 50. The stub shafts may be connected using any suitable means (e.g., welding, gluing, adhering, and the like). In yet other constructions, magnetic or non-magnetic stub shaft assemblies are connected directly to the rotor 50. The stub shaft assemblies may be connected using any suitable means (e.g., welding, gluing, adhering, through-bolts, and the like). In one construction, as illustrated in FIG. 2, a stub shaft assembly, including a stub shaft 58c and an end plate 58d, is connected to each end of the rotor 50. The stub shafts 58c are connected to the end plates 58d by a friction weld 58e, and the end plates 58d are connected directly to each end of the rotor 50 by welds 58f. In other constructions, the stub

67363-1348

- 10 -

shaft may be integrally connected to the end plate. Other types of stub shafts and/or end plates may be utilized to support the rotor 50 for rotation relative to the stator in other constructions. Generally, to minimize negative end-field effects during in-situ magnetization of the rotor assembly 15 and during motor operation, the end plates are formed of a non-magnetic and non-electrically conductive material. In some constructions, the end plates may be formed of a different material if the outside diameter of the end plate is substantially smaller in comparison to the outside diameter of the rotor 50 (FIG. 1). When stub shafts and stub shaft assemblies are utilized, the axis of rotation of the spoke permanent magnet rotor 50 may extend through the permanent magnet material 62, or the spoke permanent magnet rotor 50 may include a center hole 70 or a center core 74 filled with a magnetic or non-magnetic material. The rotor 50 may be magnetized using a conventional magnetizer and fixture.

The embodiments described above and illustrated in the figures are presented by way of example only and are not intended as a limitation upon the concepts and principles of the present invention. As such, it will be appreciated by one having ordinary skill in the art that various changes in the elements and their configuration and arrangement are possible without departing from the scope of the present invention as set forth in the appended claims.

67363-1348

- 11 -

CLAIMS:

1. A rotor assembly for an electric motor, the rotor assembly comprising:

a spoke permanent magnet rotor having an axis of rotation, permanent magnet material circumferentially surrounding the axis of rotation to form a circumferentially
5 surrounding portion of permanent magnet material and extending outwardly relative to the axis of rotation to form a plurality of outwardly extending portions of permanent magnet material, the circumferential portion defining a first interface surface, and ferro-magnetic material positioned adjacent to the outwardly extending portions of permanent magnet material and including an outer surface and a second interface surface formed inward of the
10 outer surface that engages the first interface surface, the first interface surface and second interface surface arranged to inhibit outward radial motion of the ferro-magnetic material; and

a shaft supporting the spoke permanent magnet rotor for rotation about the axis of rotation.
2. A rotor assembly as claimed in claim 1 wherein the outwardly extending
15 portions of permanent magnet material extend radially outward to the perimeter of the spoke permanent magnet rotor.
3. A rotor assembly as claimed in claim 1 wherein the ferro-magnetic material includes ferro-magnetic laminations.
4. A rotor assembly as claimed in claim 1 wherein the ferro-magnetic material
20 includes ferro-magnetic powder compacted using a compaction process.
5. A rotor assembly as claimed in claim 1 wherein the permanent magnet material includes permanent magnet powder compacted using a compaction process.
6. A rotor assembly as claimed in claim 1 wherein the ferro-magnetic material includes ferro-magnetic powder compacted using an electromagnetic compaction process, and
25 wherein the permanent magnet material includes permanent magnet powder compacted

67363-1348

- 12 -

simultaneously with the ferro-magnetic powder using the electromagnetic compaction process.

7. A rotor assembly as claimed in claim 1 wherein the ferro-magnetic material forms a plurality of pole pieces, and wherein the permanent magnet material includes plastic bonded permanent magnet material injection molded around the pole pieces.
5
8. A rotor assembly as claimed in claim 1 wherein the ferro-magnetic material forms a plurality of pole pieces, and wherein each of the plurality of pole pieces includes an interface surface that prevents movement between the respective pole piece and the permanent magnet material adjacent to the respective pole piece.
- 10 9. A rotor assembly as claimed in claim 8 wherein the interface surface includes a dovetail interface surface that forms a dovetail.
10. A rotor assembly as claimed in claim 8 wherein the interface surface includes a recess interface surface that forms a recess having a main portion and a throat portion, and wherein the throat portion is narrower than the main portion.
- 15 11. A rotor assembly as claimed in claim 1 wherein the axis of rotation extends through the permanent magnet material.
12. A rotor assembly as claimed in claim 1 wherein the shaft includes a first stub shaft and a second stub shaft, the first and second stub shafts each having an axis of rotation collinear with the axis of rotation of the spoke permanent magnet rotor, wherein the spoke
20 permanent magnet rotor includes a first end and a second end, and wherein the first stub shaft is connected to the first end and the second stub shaft is connected to the second end.
13. A rotor assembly as claimed in claim 12 wherein the shaft also includes a first end plate and a second end plate, wherein the first end plate is connected to the first end between the spoke permanent magnet rotor and the first stub shaft, and wherein the second
25 end plate is connected to the second end between the spoke permanent magnet rotor and the second stub shaft.

67363-1348

- 13 -

14. A rotor assembly as claimed in claim 1 wherein the circumferentially surrounding portion of permanent magnet material extends from a first radial position to a second radial position spaced from and outward of the first radial position, wherein the first radial position is positioned substantially adjacent the axis of rotation, and wherein the second radial position is positioned substantially adjacent the radially innermost portion of ferro-magnetic material.

15. A rotor assembly as claimed in claim 1 wherein the circumferentially surrounding portion of permanent magnet material extends from a first radial position to a second radial position spaced from and outward of the first radial position, wherein the first radial position is spaced from the axis of rotation, and wherein the second radial position is positioned substantially adjacent the radially inner most portion of ferro-magnetic material.

16. A rotor assembly as claimed in claim 15 wherein the first radial position is positioned substantially adjacent to an outermost portion of the shaft, and wherein the axis of rotation extends through the shaft.

17. A rotor assembly as claimed in claim 15 wherein the first radial position is positioned substantially adjacent to an outermost portion of a hollow portion, and wherein the axis of rotation extends through the hollow portion.

18. A rotor assembly as claimed in claim 15 wherein the first radial position is positioned substantially adjacent to an outermost portion of a core portion, wherein the axis of rotation extends through the core portion, and wherein the core portion includes at least one of a magnetic material and a non-magnetic material.

19. A rotor assembly for an electric motor, the rotor assembly comprising:
a permanent magnet rotor having an axis of rotation, a center portion of permanent magnet material, a plurality of angularly spaced spoke portions of permanent magnet material extending outwardly from the center portion of permanent magnet material, and ferro-magnetic material positioned between the angularly spaced spoke portions of permanent magnet material; and

67363-1348

- 14 -

a shaft supporting the permanent magnet rotor for rotation about the axis of rotation, wherein the ferro-magnetic material forms a plurality of pole pieces, and wherein the permanent magnet material includes plastic bonded permanent magnet material injection molded around the pole pieces, wherein the permanent magnet material and the ferro-
5 magnetic material have an interface therebetween that prevents the ferro-magnetic material adjacent to the interface from moving outwardly during rotation of the spoke permanent magnet rotor about the axis of rotation.

20. A rotor assembly as claimed in claim 19 wherein the center portion of permanent magnet material includes a hollow portion, and wherein the axis of rotation
10 extends through the hollow portion.

21. A rotor assembly as claimed in claim 19 wherein the center portion of permanent magnet material surrounds the shaft, and wherein the axis of rotation extends through the shaft.

22. A rotor assembly as claimed in claim 19 wherein the center portion of
15 permanent magnet material surrounds a core portion, wherein the axis of rotation extends through the core portion, and wherein the core portion includes a non-magnetic material.

23. A rotor assembly as claimed in claim 19 wherein the center portion of permanent magnet material is solid.

24. A rotor assembly for an electric motor, the rotor assembly comprising:
20 a spoke permanent magnet rotor having an axis of rotation, permanent magnet material extending outwardly relative to the axis of rotation to form a plurality of outwardly extending spoke portions of permanent magnet material, at least one of the plurality of spoke portions defining a first interface surface, the permanent magnet material including permanent magnet powder compacted using an electromagnetic compaction process, and ferro-magnetic
25 material positioned adjacent to the outwardly extending spoke portions of permanent magnet material and including an outer surface and a second interface surface formed inward of the

67363-1348

- 15 -

outer surface that engages the first interface surface, the first interface surface and second interface surface arranged to inhibit outward radial motion of the ferro-magnetic material; and

a shaft supporting the spoke permanent magnet rotor for rotation about the axis of rotation.

- 5 25. A rotor assembly as claimed in claim 24 wherein the shaft includes a through-shaft assembly having a magnetic through-shaft and a non-magnetic sleeve surrounding at least a portion of the magnetic through-shaft, and wherein the outwardly extending spoke portions of permanent magnet material extend radially outward from the non-magnetic sleeve.
26. A rotor assembly as claimed in claim 24 wherein the ferro-magnetic material
10 includes ferro-magnetic powder compacted simultaneously with the permanent magnet powder using the electromagnetic compaction process.
27. A rotor assembly as claimed in claim 24 wherein the permanent magnet material circumferentially surrounds the axis of rotation to form a circumferentially surrounding portion of permanent magnet material.
- 15 28. A rotor assembly as claimed in claim 27 wherein the axis of rotation passes through the permanent magnet material.
29. A rotor assembly as claimed in claim 24 wherein the permanent magnet material forms a center portion of permanent magnet material, and wherein the outwardly extending spoke portions of permanent magnet material extend radially outward from the
20 center portion of permanent magnet material.
30. A rotor assembly as claimed in claim 24 wherein bolts do not extend through the ferro-magnetic material.
31. A method of constructing a rotor assembly for an electric motor, the method comprising:

67363-1348

- 16 -

compacting permanent magnet powder and ferro-magnetic powder using an electromagnetic compaction process to form a spoke permanent magnet rotor, the compacted permanent magnet powder forming a center portion of permanent magnet material and a plurality of spoke portions of permanent magnet material extending outwardly from the center portion of permanent magnet material, wherein at least one of the center portion and one of the plurality of spoke portions defines a first interface surface, and the compacted ferro-magnetic powder forming a plurality of pole pieces, each pole piece being positioned between a respective set of circumferentially adjacent spoke portions of permanent magnet material and including an outer surface and a second interface surface formed inward of the outer surface;

engaging the first interface surface and the second interface surface to inhibit outward radial motion of the ferro-magnetic pole pieces; and

supporting the spoke permanent magnet rotor on a shaft for rotation about an axis of rotation.

32. A rotor assembly for an electric motor, the assembly comprising:

a spoke permanent magnet rotor having an axis of rotation, permanent magnet material extending outwardly relative to the axis of rotation to form a plurality of outwardly extending spoke portions of permanent magnet material, at least one of the plurality of spoke portions defining a first interface surface, ferro-magnetic material forming a plurality of pole pieces, each pole piece being positioned between a set of circumferentially adjacent outwardly extending spoke portions of permanent magnet material, at least one of the pole pieces including a second interface surface that engages the first interface surface to inhibit outward radial motion of the at least one pole piece, the permanent magnet material including injection molded plastic bonded permanent magnet material; and

a shaft supporting the spoke permanent magnet rotor for rotation about the axis of rotation.

67363-1348

- 17 -

33. A rotor assembly as claimed in claim 32 wherein the plastic bonded permanent magnet material is injection molded around the pole pieces in an injection molding process.

34. A rotor assembly as claimed in claim 32 wherein at least one pole piece includes an interface surface that prevents movement between the at least one pole piece and
5 the permanent magnet material adjacent to the at least one pole piece.

35. A rotor assembly as claimed in claim 32 wherein the permanent magnet material circumferentially surrounds the axis of rotation to form a circumferentially surrounding portion of permanent magnet material.

36. A rotor assembly as claimed in claim 35 wherein the axis of rotation passes
10 through the permanent magnet material.

37. A rotor assembly as claimed in claim 32 wherein the permanent magnet material forms a center portion of permanent magnet material, and wherein the outwardly extending spoke portions of permanent magnet material extend radially outward from the center portion of permanent magnet material.

15 38. A rotor assembly as claimed in claim 32 wherein bolts do not extend through the pole pieces.

39. A method of constructing a rotor assembly for an electric motor, the method comprising:

providing a plurality of ferro-magnetic pole pieces;

20 injection molding plastic bonded permanent magnet material to form a spoke permanent magnet rotor, the injection molded plastic bonded permanent magnet material forming a center portion of permanent magnet material and a plurality of spoke portions of permanent magnet material extending outwardly from the center portion of permanent magnet material, and each pole piece being positioned between a respective set of circumferentially
25 adjacent spoke portions of permanent magnet material;

67363-1348

- 18 -

interlocking the permanent magnet material and the ferro-magnetic pole pieces to inhibit radially outward movement of the ferro-magnetic pole pieces with respect to the permanent magnet material; and

5 supporting the spoke permanent magnet rotor on a shaft for rotation about an axis of rotation.

40. A method as claimed in claim 39 wherein injection molding plastic bonded permanent magnet material includes injection molding plastic bonded permanent magnet material around the pole pieces.

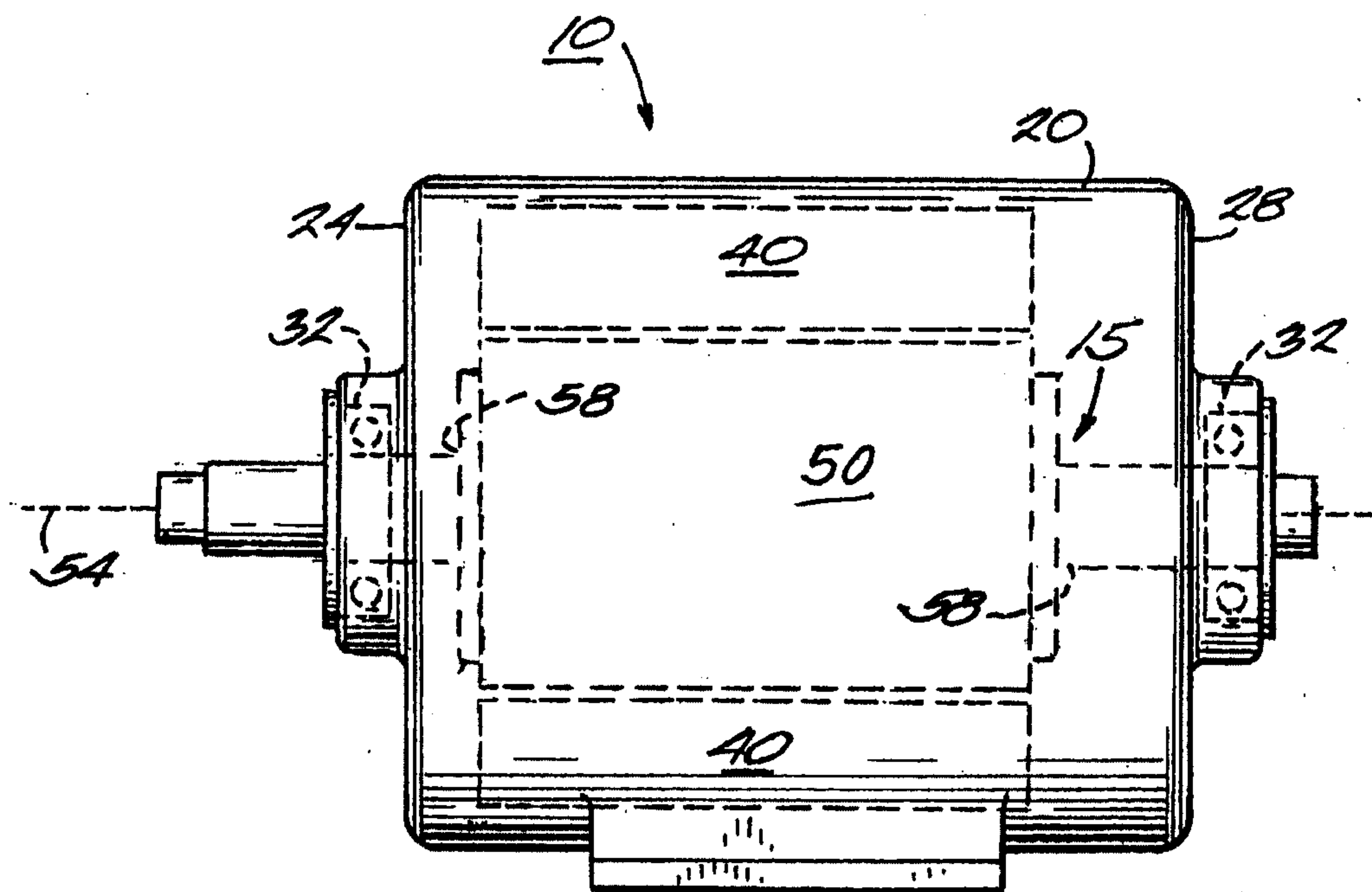

Fig. 1

