

I. H. ATHEY.
DROP FRONT DRAWER FOR FILING CABINETS.

APPLICATION FILED JULY 3, 1905.

FIG. 1.

FIG. 6.

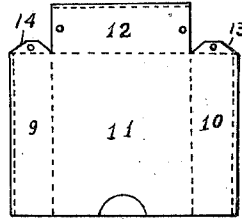
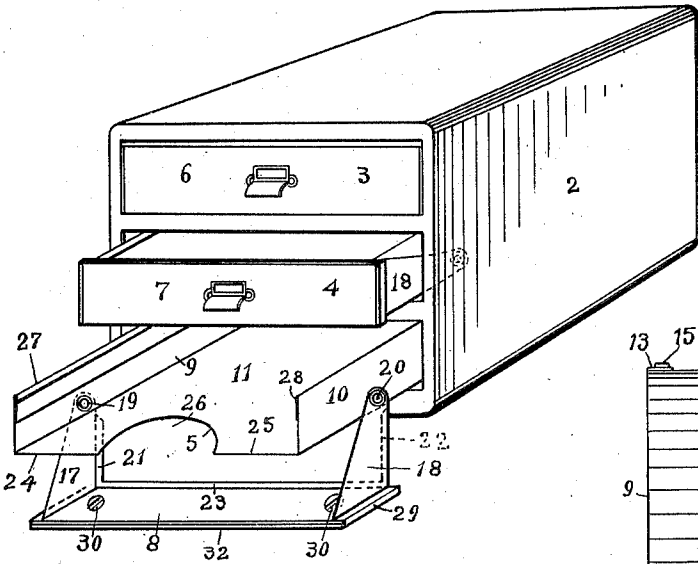

FIG. 3.

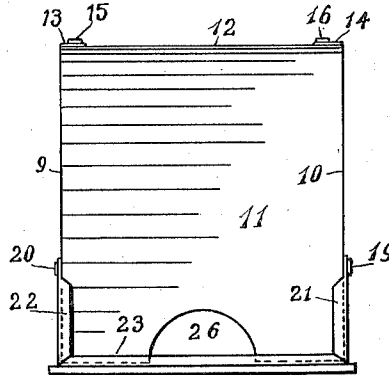

FIG. 4.

FIG. 2.

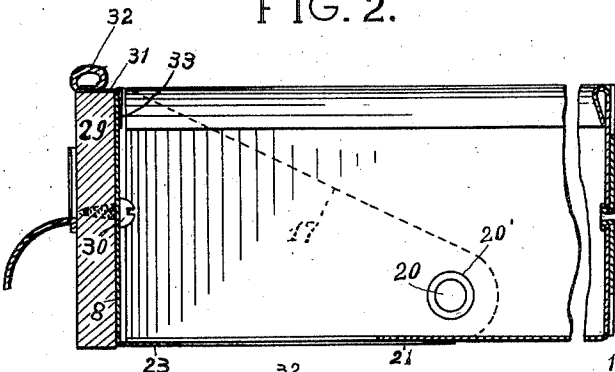
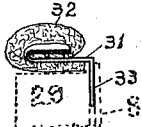

FIG. 5.



WITNESSES:

Thomas Gray
J. Edward King

INVENTOR

Isaac H. Athey
BY
Harold Jackson
ATTORNEY

UNITED STATES PATENT OFFICE.

ISAAC H. ATHEY, OF CHICAGO, ILLINOIS, ASSIGNOR TO DUST PROOF FURNITURE COMPANY, A CORPORATION OF ILLINOIS.

DROP-FRONT DRAWER FOR FILING-CABINETS.

No. 821,577.

Specification of Letters Patent.

Patented May 22, 1906.

Application filed July 3, 1905. Serial No. 268,269.

To all whom it may concern:

Be it known that I, ISAAC H. ATHEY, a citizen of the United States, residing at Chicago, in the county of Cook and State of Illinois, have invented certain new and useful improvements in Drop-Front Drawers for Filing-Cabinets, of which the following is a specification.

This invention relates to the construction of drawers for filing-cabinets and the like; and its object is to provide certain improvements for the purpose of simplifying and strengthening drawers; to provide a construction which will economize space allotted for the drawers, which is comparatively rigid and which overcomes some of the objections to drawers whose bottoms are joined to the sides and ends of drawers; and with the above-named objects in view the invention consists in the novel construction and combination of parts hereinafter described in detail, illustrated in the drawings, and incorporated in the claims.

In the drawings, Figure 1 is a perspective view of a filing-cabinet provided with three drawers constructed in accordance with my invention. Fig. 2 is a longitudinal and vertical section through one of the drawers, a portion thereof being broken away. Fig. 3 is a bottom plan view of one of the drawers. Fig. 4 is a top plan view of same. Fig. 5 is an enlarged view of the dust-proof device shown in Fig. 2 combined with a drawer embodying my invention. Fig. 6 is a plan view, drawn on a reduced scale, of the blank from which the drawer is formed.

Referring to the drawings, 2 represents the body of the cabinet, having drawer-spaces therein, each of which is either provided with a bottom or the usual side rails for the drawers to slide upon.

Numerals 3, 4, and 5 represent identical drawers in different positions. The board front 6 of the drawer 3 is shown entirely closed, while the identical front 7 of drawer 4 is partly drawn out, though not sufficient to permit the said front to drop down to the position occupied by the front on the lowest drawer 5. As the position of the latter drawer discloses all its front, the reference characters are applied to drawer 5 in Fig. 1.

The whole drawer proper, including the drop-front 8, is made of but two pieces of sheet metal. The drawer, exclusive of the

front 8, is made from a single piece of sheet metal cut substantially in the form shown in Fig. 6 and bent or folded along the dotted lines. The parallel sides 9 and 10 and the rear side or end 12 are integral with the bottom portion 11, being upwardly-bent extensions of the latter. On the rear ends of sides 9 and 10 are laterally-extending wings or flanges 13 and 14, which are extensions of said sides. These flanges overlap the ends of the back 12 of the drawer and are secured to said ends by means of hollow rivets or eyelets 15 and 16. The drop-front 8 in its full-open position is back of the vertical plane which it occupies when in its closed position, and said front comprises the sheet-metal part 8, from which are struck up or bent a pair of bracket portions or wings 17 and 18, pivoted at 19 and 20 to, respectively, the sides 9 and 10. As shown, these flanges lie against the outer sides of the parts 9 and 10, and by using hollow pivots or rivets 19 and 20 a strong upset portion or rivet-flange 20' is very easily formed and same produces but a slight surface projection. The wings 17 and 18 have laterally-bent portions or flanges 21 and 22, which, together with a similar flange 23, formed on the front 8, not only serve as stops limiting the upward movement of the front, but also perform other important functions. The flanges 21 and 22 serve as runners or slide-plates, upon which the front 8 is supported for a smooth and free movement along the slide-supports in case 2 for the respective drawers. The flange 23, on the other hand, effects complete closure between the forward edges 24 and 25 and the front 8, so that papers standing on edge, accidentally or otherwise, against said front cannot drop out of the drawer. A portion of the forward edge of bottom 11 has the usual handhold-recess 26.

It will be seen that the above-described construction provides a drop-front, together with means for supporting and effectively closing it against the body of the drawer without adding more than one thickness of sheet metal to each of the sides 9 and 10 and to the bottom 11 and at the same time the flanges 21, 22, and 23 serve as stiffening-ribs that support the front against bending or flexing under such pull upon it as would be exerted when the drawer is full of papers. The sides of the drawer are shown provided

with stiffening-ribs 27 and 28, which consist of one or more folds of the upper edges of said sides. These ribs may be made tubular, if desired. A well-known objection to the common form of cabinet-drawer is the joints between bottom and sides, which often open sufficiently to catch and hold papers. This difficulty is entirely overcome by obviating joints at the corners where bottom and sides meet. In lieu of joints along the bottom, which are apt to catch and tear papers, my construction places such joints as are necessary along lines vertical to the bottom and to papers or documents placed thereon. Bending the metal upward to form the sides also leaves the outside corners smooth and slightly rounded and facilitates easy sliding movement of the drawer or tray upon its bearings in the drawer-opening of the cabinet.

For the purpose of retaining the wood effect for the drawers in cabinets otherwise made out of wood I have provided a false board front 29, which is held to the front 8 by means of screws 30 passing through suitable apertures in the metal front 8 into the board front 29 from the inside of drawer, so that the fastening means or screws shall not be observable at the front of the cabinet.

In Figs. 2 and 5 I have shown my construction in combination with a holder 31 for a felt cushion 32. This holder is provided with a wing or flange 33, which is clamped between the metal front 8 and false front 29.

Having thus described my invention, what I claim as new, and desire to obtain by Letters Patent, is—

1. A drawer consisting of a single piece of sheet metal bent to form the bottom, sides and rear end of a drawer, said sides and end having overlapping parts which are riveted together, and the overlaps arranged to extend vertically to said bottom, said bottom and end constructed to provide a continuous or unbroken surface where said bottom and sides come together, and a pivoted front constructed and arranged to normally close the front of the drawer and to overlap portions of the outer faces of the sides and under side of the bottom.

2. A filing-cabinet drawer open at one side and consisting of a plate of sheet metal cut and bent into a form, said form comprising a bottom and three sides, the latter, at their junction with said bottom arranged to form an unbroken or continuous surface, means for fastening the abutting sides of said ends together, and a pivotally-movable drop-front arranged to normally close the open side and to horizontally overlap the front edges of the bottom in such a manner that papers cannot drop edgewise past said front and front edges.

3. A filing-cabinet drawer, consisting of a plate of sheet metal cut and bent into a form which comprises a bottom and two sides 9 and 10 as well as a rear end or side 12, which

are continuous with said bottom, said sides and end having overlapping portions or flanges, which are riveted to said rear end 12, and a drop-front constructed and arranged to normally close the front end of the drawer and to also close the slight space between the drop-front and sides and bottom, in planes at right angles to the plane of the drop-front when same is in its closed position.

4. A filing-cabinet drawer, consisting of a plate of sheet metal cut and bent in the form of a drawer, the sides 9 and 10 of which are riveted to the rear end 12, said sides and end being extensions of said bottom bent upwardly, and a pivoted drop-front formed from a single piece of sheet metal in such a manner as to provide stiffening-ribs which serve to support the front against bending strains.

5. A drawer, consisting of a single sheet of metal cut and bent to form a bottom, sides rear end and stiffening-ribs for the upper edges of said sides, and a drop-front also consisting of a single sheet of metal having integral stiffening-ribs arranged to normally lie against said bottom and sides.

6. A drawer, consisting of a single sheet of metal cut and bent to form a bottom, two sides and a rear end, means for securing said sides and end to each other, said sides and end having stiffening-ribs formed by bending a portion of the upper edges thereof upon themselves, and a front for said drawer which also consists of a single sheet of metal having integral therewith wings 17 and 18 pivoted to said sides, said front and wings having integral therewith flanges 21, 22 and 23 which overlap the front edges of the drawer, the flanges 21 and 22 arranged to serve as slide-bearings for said front, the flange 23 constructed to serve as a closure between said front and the bottom of said drawer, and all three of said flanges arranged to serve as stiffening-ribs for said front.

7. A drawer, consisting of a single sheet of metal cut and bent into a form which comprises the bottom 11, the sides 9 and 10 and the rear end 12, said bottom, sides and rear end being constructed so that their joints run along vertical lines relative to the bottom, whereby the latter is a continuation of said sides and end, and a sheet-metal front having integral wings 17 and 18, which are provided with flanges 21 and 22 that serve as slides upon which said front moves upon the bearings provided for the drawer as a whole.

8. A drawer, consisting of a single sheet of metal cut and bent into a form that comprises the bottom 11 and the sides 9 and 10 and rear end 12 extending from and integral with said bottom; means for fastening said sides and end together; a drop-front for said drawer consisting of a single piece of sheet metal having bent portions 17 and 18 pivoted to the sides of said drawer; and

flanges 21, 22 and 23 arranged to serve as stops limiting the upward movement of said front as well as stiffening-ribs; the flanges 21 and 22 thereof arranged to serve as runners or slides upon which said front is supported vertically when in a closed, or partly-closed position.

9. A drawer, consisting of a single piece of sheet metal cut and bent into the form which comprises the bottom 11, the sides 9 and 10 and the rear end 12; said sides, bottom and rear end being one continuous piece of metal, said sides and end having joints arranged vertically to said bottom; the front 8, having thereon the flanges or ribs 21, 22 and 23 and the wings 17 and 18 pivoted to the sides 9 and 10; and the false front 29 secured to the outer face of said front 8.

10. A sheet-metal drawer consisting of a

single sheet of metal bent into a form which comprises the bottom 11, the sides 9 and 10 and rear end 12, said bottom, sides and rear end being constructed so that their joints are arranged on vertical lines relative to bottom; a front 8 having the wings 17 and 18 arranged to serve as supporting-brackets for said front, the latter provided with a flange 23, said wings provided with flanges 21 and 22; a false front 29 secured to said front 8, and a dust-proof strip having a wing 33 secured between said fronts 8 and 29.

In testimony whereof I have hereunto set my hand in the presence of two subscribing witnesses.

ISAAC H. ATHEY.

Witnesses:

FRED L. KOEHLER,
J. EDWARD KING.