

C. D. TISDALE.  
Electric Railroad Signal.

No. 229,285.

Patented June 29, 1880.

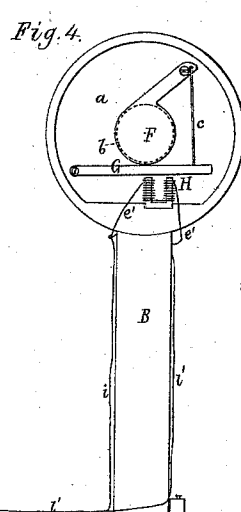
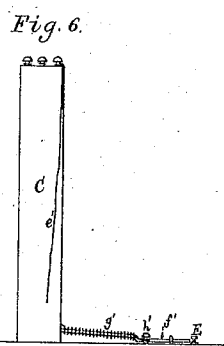
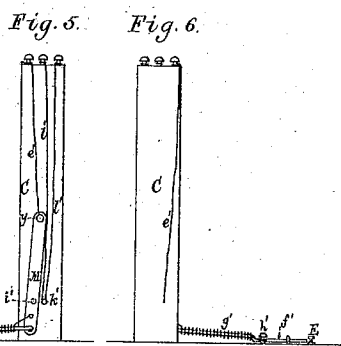
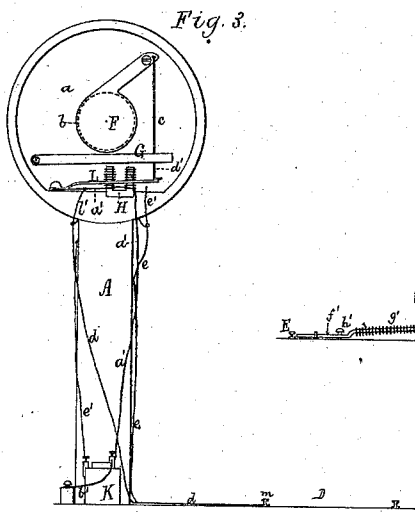
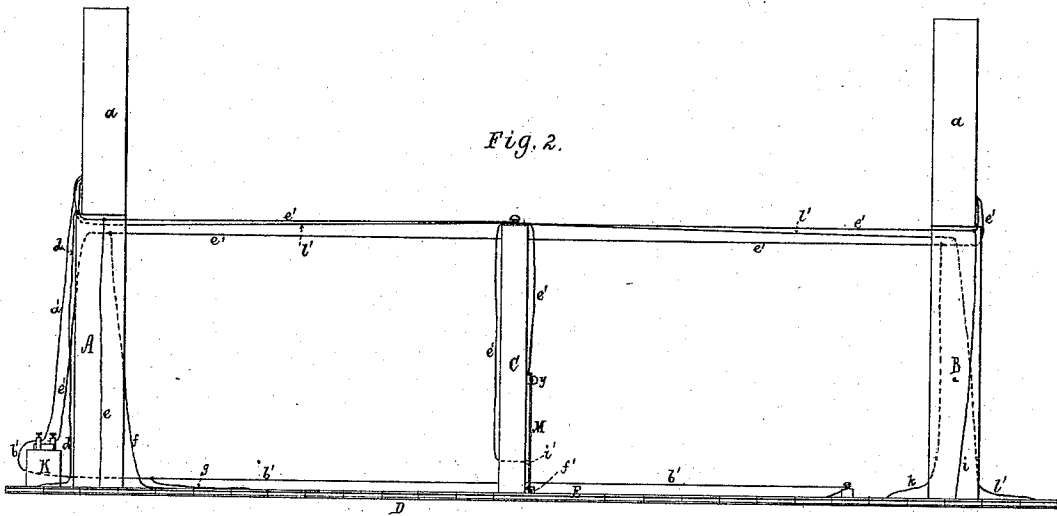
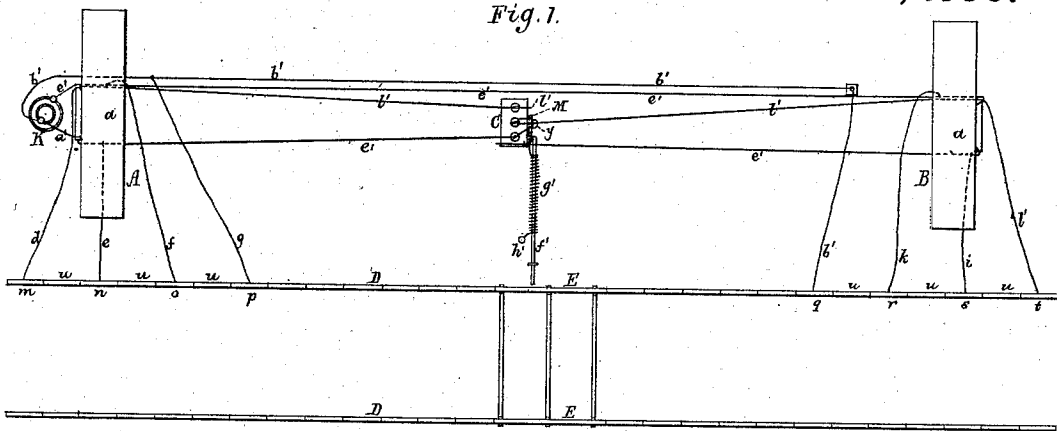

Witnesses.

S. N. Piper  
H. H. Lund

Inventor.

Chas. D. Tisdale

# UNITED STATES PATENT OFFICE.

CHARLES D. TISDALE, OF BOSTON, MASSACHUSETTS.

## ELECTRIC RAILROAD-SIGNAL.

SPECIFICATION forming part of Letters Patent No. 229,285, dated June 29, 1880.

Application filed September 6, 1879.

*To all whom it may concern:*

Be it known that I, CHARLES D. TISDALE, of Boston, of the county of Suffolk and State of Massachusetts, have invented a new and useful Improvement in Electric Signal Apparatus for Railways; and I do hereby declare the same to be described in the following specification and represented in the accompanying drawings, of which—

10 Figure 1 is a top view, Fig. 2 a front elevation, and Figs. 3 and 4 opposite end views, of it. Figs. 5 and 6 are opposite side elevations of the intermediate or switch post with the devices applied thereto.

15 The nature of my invention is set forth in the claim or claims hereinafter presented.

This signal apparatus is to give notice to a car or train, when approaching either of the two next adjacent signal-posts, whether the section of track between them is clear of any train or car, or, when there is a switch in the section, whether such switch is closed or in a correct position for the train or car to pass throughout the section.

25 In this apparatus, when the signals are down, so as to cover their openings of the signal-post heads, a car or train is to be supposed to be on the section, or that the switch is open or not in alignment with the track-rails, in which case it will not be safe for another or approaching car or train to pass upon and through the section.

30 The two signal-posts are generally to be placed a mile, or about that distance, apart, the switch and its post being intermediate of or between them, in manner substantially as represented.

35 In the drawings, A and B denote the two signal-posts, and C the intermediate or switch post, all of which are arranged aside of and close to a railway-track, D D, and a switch, E E, thereof.

40 Each of the signal-posts A B has a circular box-head, *a*, provided at its central part with a circular opening, *b*, and within each head is a lever-signal, F, which is pivoted to the head, so as when down to cover the opening *b* thereof.

45 Arranged below each signal is an armature or box, G, which, near one end of it, is pivoted to the head *a*, it being disposed over an electro-magnet, H, and connected near its free

end by a rod, *c*, with the shorter arm of the signal-lever.

Near each post four wires proceed from the track, those of the post A being marked *d e f g* and those of the post B being marked *h i k l*. Each wire leads from a separate rail of the next line of rails of the track, these rails being in Fig. 1 marked *m n o p* for post A and *q r s t* for post B. The rail to which each wire is attached is to be electrically insulated from those next it, though there may be between any two next adjacent of such rails one or more line-rails, as shown in the drawings at *u*.

60 The galvanic battery is represented at K. From one of its poles two wires, *a' b'*, are led, while one wire, *e'*, is led from the other pole. The wire *a'* leads to and around the first magnet, H, and thence to the heel of a circuit-closer or metallic spring, L, arranged as shown, such spring being bent inward near its free end, in order that when the armature G near it is depressed such armature, or a bent-wire projection, *d'*, extending down from it, may be carried in contact with the spring L and cause it to be moved into contact with a turned-in portion of the circuit-wire *e'*. The said wire *e'* is continued from directly under the spring L to and down the intermediate post, C, to the metallic pivot *y* of a metallic vibratory arm, M, such arm being arranged against one side of the post and pivoted thereto.

75 From the arm M a rod, *f'*, extends nearly to the switch-rail E when the switch is closed. The rod should not touch the switch, or should be insulated from it, when the switch is closed in the main track. The turnout-track is not shown in the drawings. It is to be supposed to be arranged with the switch and main track in the usual manner, the switch being open when in alignment with the turnout-track or out of alignment with the main track.

80 A spring, *g'*, suitably applied to a stationary stud, *h'*, and wound around the rod and attached to the arm M, serves to move or draw back the said arm M and the rod *f'* while the switch is being moved into alignment with the main track.

85 The arm M is to operate with two metallic studs, *v' w'*, inserted in the post C. From the stud *v'* the circuit-wire *e'*, broken or interrupted between the pivot of the arm M and the stud

*i'*, continues from the said stud up the opposite side of the post C, and thence to and about the magnet H of the post B, and thence to the other pole of the battery.

5 About the stud *k'* a wire, *l'*, is carried in its passage from the wire *a'* at the magnet of the post A, such wire passing up to the top of the post C, and going from thence to and down the post B, and thence to the rail *t*.

10 The wire *i*, attached to the rail *s*, is led to the post B, thence up the said post to the circuit-wire *e'*.

From the first-mentioned pole of the battery the short-circuit wire *b'*, before referred to, is led to the rail *q*.

15 The wire *k* from the rail *r* leads toward and up the post B, and is coupled with the circuit-wire *e'* near the magnet of the post B, as shown.

20 The wire *g*, leading from the rail P, couples with the short-circuit wire *b'*. The wire *f*, leading from the rail *o*, goes to and up the post A and couples with the main-circuit wire *e'*. So the wire *e*, leading from the rail *n*, goes to and up the post A and couples with the circuit-wire *e'* directly in front of the said post.

25 The wire *d* from the rail *m* leads to and up the post A and couples with the magnet-wire *l'* near where such wire is coupled with the wire *a'*.

30 From the above it will be seen that the operative electric circuits are as follows—that is to say: First, the main circuit, or that between the two posts A B, starts from one pole of the battery by the wire *a'* and continues through the same to and around the magnet of the post A, and from thence to the heel of the spring L, thence through said spring to the turned-in portion of the wire *e'*, thence through said wire to and around the magnet of the post B, and from thence to the other pole of the battery.

35 One short circuit, for breaking the main circuit by means of a car, when going from the post A toward the post B, commences with the rail *p*, passes through the wire *g* to the wire *b'*, thence to one pole of the battery, thence from the other pole of said battery, through the wire *e'*, to and through the wire *f* and to the rail *o*, it being completed when the wheels of the car are on the rails *o* and *p*.

40 After the main circuit has been broken it will be closed, when the wheels of the car, in going from the post A to the post B, may reach and rest upon the rails *s t*, the circuit then through such rails being as follows—that is to say, by the wire *l'* to the wire *a'* near the magnet of the post A, thence around said magnet to one pole of the battery, thence from the other pole of said battery through the wire *e'*, thence to and around the magnet of the post B, thence through the wire *i* to the rail *s*, thence through the wheels of the car to the rail *t*.

65 When the train is going from the post B toward the post A the short breaking circuit is made or closed by the wheels resting upon the

rails *q* and *r*, in which case the current is from the rail *q*, through the wire *b'*, to one pole of the battery, thence from the other pole to and through the wire *e'*, the wire *k*, and thence through the latter to the rail *r*, thence through the wheels of the car to the rail *q*.

70 On the car passing upon the rails *m* and *n* the main circuit will be closed. Starting from the rail *m*, said circuit is through the wire *d* to its coupling with the wire *l'*, thence through said wire *l'* to the wire *a'*, thence through said wire *a'* around the magnet of post A, thence down the wire *a'* to the pole of the battery. From the other pole it is through the wire *e'* to and around the magnet of the post B, and from thence, by the wire *e'*, to and through the wire *e* to the rail *n*, and through the wheels to the rail *m*.

85 The operation of the apparatus as above described may be thus explained.

80 We will suppose a train or car to be approaching the post A and to run therefrom to the post B, and that the track between the said posts is clear and the switch closed; the circuit of both magnets will be closed, and the target or signal-levers will be up so as to uncover the holes of the post-heads. Should there be a car or train on the section or the switch be open the targets will be down.

90 On the car or train entering the section and two wheels of the engine or car coming at once into contact with the two rails *o p*, the main circuit will be broken and the magnets will cease to hold down the armatures; consequently both targets will drop. On the car or engine passing upon the two rails *s t* the main circuit will be closed and the targets be raised up. So on the car or train entering the section and passing through it the opposite way, when the wheels come into contact with the rails *r* and *q*, the main circuit will be broken and the targets will fall, such main circuit being closed when the wheels may be on the rails *m* and *n*, in which case the targets will rise. The wheels that are in contact with the two insulated rails are to be supposed to be electrically connected—that is, so that the electric current can pass from one to the other of them.

95 We will now suppose the switch to be moved for the purpose of opening it into alignment with the turnout-track. On the arm M passing off the stud *i'* the main circuit would be broken and the targets would fall were it not that the arm M is carried in contact with the stud *k'* before such arm may leave the stud *i'*. The arm M, continuing to move, passes off the stud *k'* on the switch coming into alignment with the turnout, and consequently the circuit becomes broken and the targets fall and the bent wire *d'* becomes raised off the spring L. Were it not for the stud *k'* and the wire *l'*, leading to the circuit-wire at the magnet of the post A, the main circuit could not be closed when the arm M might reach the stud *i'*, for the wire *d'* would be off the spring L, whereby there would be a break in the circuit. As soon, during the return movement of the switch,

as the arm M is carried in contact with the stud *k'* the circuit will be closed and the targets will be raised, the said break in the circuit being then closed. On the arm M passing to the stud *i'* the circuit will be kept closed when the arm leaves the stud *k'*.

The electric signal apparatus described in the specification of Letters Patent No. 218,693, dated August 19, 1879, granted to me, was specially intended for a double-track railway, where the trains going in one direction always run on one track, and when going the opposite way they run on the other track. The circuit in such case had to be broken on a train entering the section of track and closed on passing therefrom.

My present signal apparatus is for a single-track railway on which the trains run each way, or on which two trains may approach each other on the same track.

To adapt the electric signal apparatus to the single-track railway it will be seen that at or near each end of the section provision is made both for closing and breaking the circuit, and that this is accomplished in part by means of certain of the rails of the track and by the wheels of a truck or carriage, all as described.

In case of there being no switch in the sec-

tion the circuit-wire *e'* is to continue unbroken or uninterrupted from one post, A, to the other, B, there being under such circumstances no intermediate post, C.

Having thus described my invention, what I claim as such is as follows:

1. The single-track electric signal apparatus or combination, substantially as described, consisting of the four sets of insulated rails *m n*, *o p*, *q r*, and *s t*, the battery K, continuous-circuit wire *e'*, magnets H, circuit closer or spring L, wires *d*, *e*, *f*, *g*, *a'*, *b'*, *k*, *i*, and *l'*, and the armatures G and signal-levers F, all adapted to operate essentially as set forth, and for use on a track without a switch.

2. The combined single-track and switch-signal apparatus or combination of the studs *i' k'*, vibratory arm M, rod *f'*, and spring *g'*, adapted to the post C, and the switch, as described, with the four sets of insulated rails *m n*, *o p*, *q r*, and *s t*, the battery K, the circuit-wires *e'*, magnets H, circuit-closer or spring L, wires *d*, *e*, *f*, *g*, *a'*, *b'*, *k*, *i*, and *l'*, and the armatures G and signal-levers F, all being applied and to operate substantially as set forth.

CHARLES D. TISDALE.

Witnesses:

S. N. PIPER,  
W. W. LUNT.