

G. H. PROCTOR.
INCANDESCENT LAMP SOCKET.
APPLICATION FILED MAY 10, 1904.

2 SHEETS—SHEET 1.

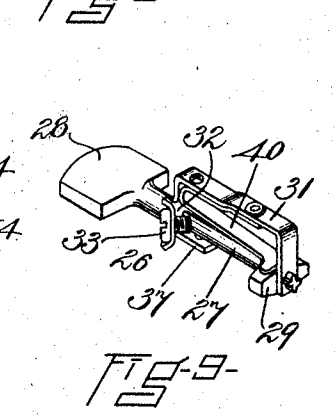
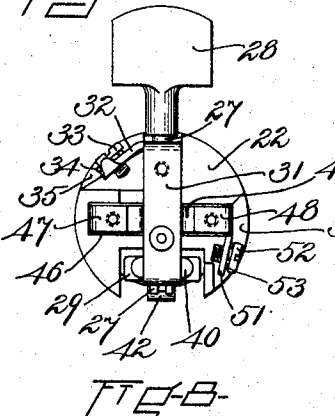
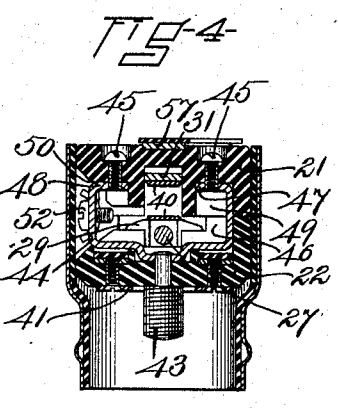
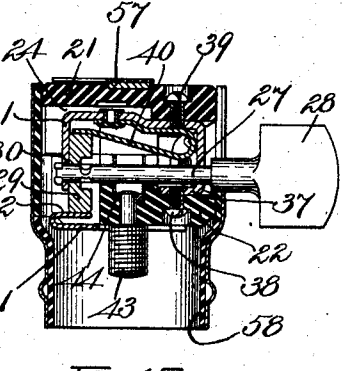
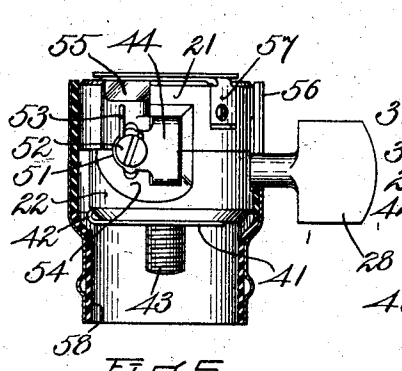
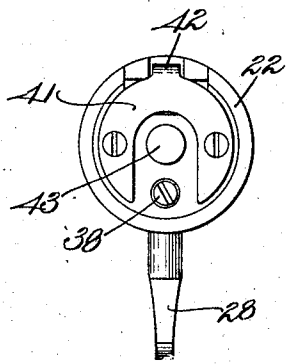
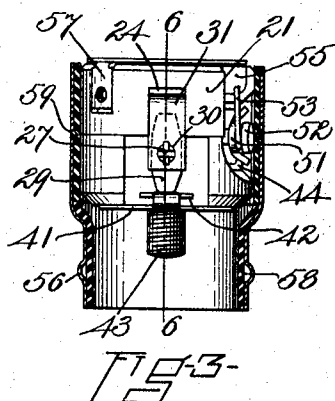
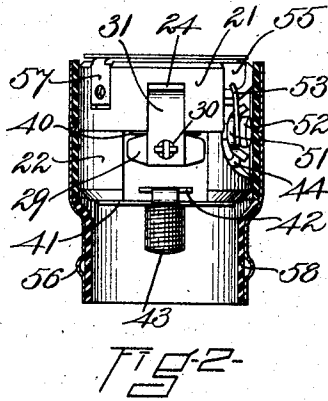
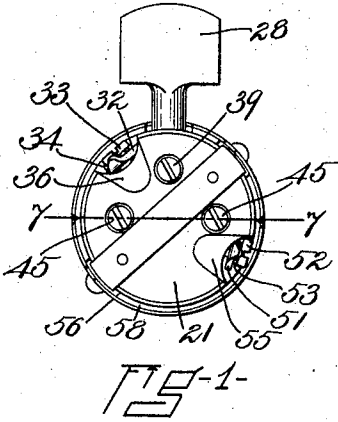

WITNESSES:
Franklin E. Low
Louis A. Jones.

INVENTOR:
G. H. Proctor.
by his Attorney, Charles S. Gooding.

G. H. PROCTOR.
INCANDESCENT LAMP SOCKET.

APPLICATION FILED MAY 10, 1904.

2 SHEETS—SHEET 2.

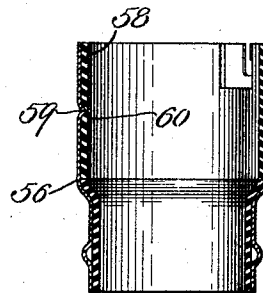
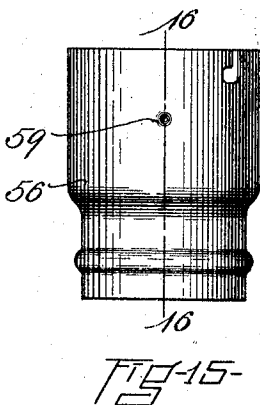
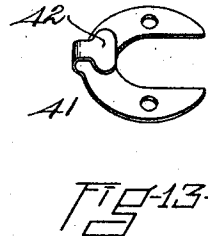
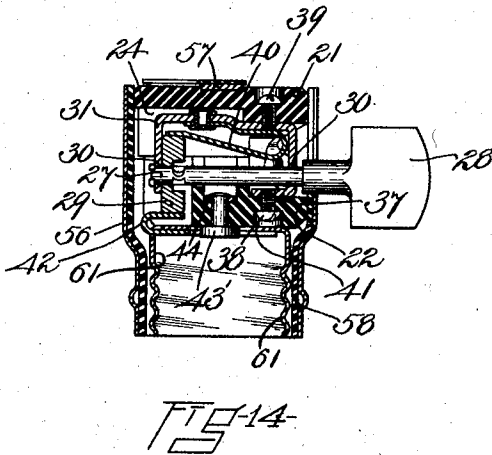
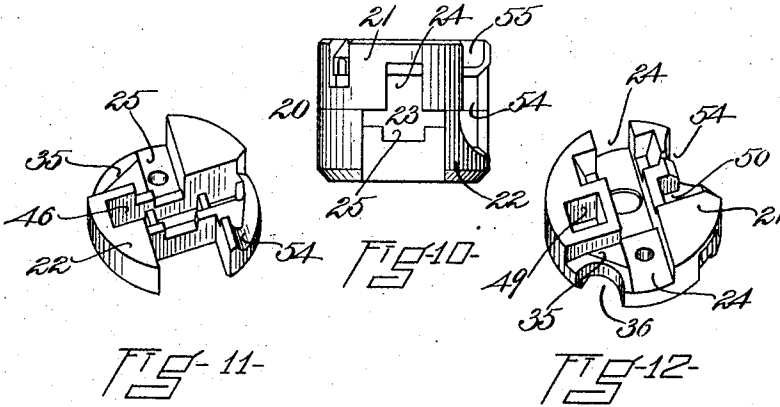

WITNESSES:
Franklin C. Low.
Lewis A. James.

INVENTOR:
GUY H. PROCTOR.
By His Attorney, Charles J. Gooding.

UNITED STATES PATENT OFFICE.

GUY H. PROCTOR, OF SOMERVILLE, MASSACHUSETTS, ASSIGNOR, BY MESNE ASSIGNMENTS, TO THE BRYANT ELECTRIC COMPANY, OF BRIDGEPORT, CONNECTICUT, A CORPORATION OF CONNECTICUT.

INCANDESCENT-LAMP SOCKET.

SPECIFICATION forming part of Letters Patent No. 790,152, dated May 16, 1905.

Application filed May 10, 1904. Serial No. 207,280.

To all whom it may concern:

Be it known that I, GUY H. PROCTOR, a citizen of the United States, residing at Somerville, in the county of Middlesex and State of Massachusetts, have invented new and useful Improvements in Incandescent-Lamp Sockets, of which the following is a specification.

This invention relates to sockets for incandescent lamps, the object of the invention being to provide a safe, simple, and practical lamp-socket the different parts of which may be economically constructed, quickly and easily taken apart, and firmly fastened together.

The invention consists in the combination and arrangement of parts set forth in the following specification and particularly pointed out in the claims thereof.

Referring to the drawings, Figure 1 is a top plan view of my improved lamp-socket with the key in position to break the circuit. Fig. 2 is a front elevation of the same with metal shell and insulating-lining in section in connection therewith. Fig. 3 is a view similar to Fig. 2, showing the circuit-controlling key turned at right angles to the position shown in Fig. 2 and completing the circuit. Fig. 4 is an underneath plan of the same with the key turned as in Fig. 3. Fig. 5 is a side elevation viewed from the right of Fig. 3 with the metal shell and insulating-lining shown in section in connection therewith. Fig. 6 is a vertical longitudinal section, partly in elevation, taken on line 6 6 of Fig. 3, looking toward the left in said figure. Fig. 7 is a vertical transverse section, partly in elevation, taken on line 7 7 of Fig. 1. Fig. 8 is a detail plan of the socket viewed as in Fig. 1 with the upper half of the socket removed. Fig. 9 is a perspective view of the circuit-controlling key, together with the bearing-plate upon which the shaft of said key is arranged to rotate. Fig. 10 is a detail front elevation of the insulating supporting-block. Fig. 11 is a perspective view of the lower half of the insulating-block. Fig. 12 is a perspective view of the upper half of the insulating-block inverted. Fig. 13 is a perspective view of the central contact-plate. Fig. 14 is a verti-

cal central section similar to Fig. 6, illustrating a modified means for attaching the lamp to the socket. Fig. 15 is a right-hand side elevation of the metal shell which surrounds the socket. Fig. 16 is a vertical section taken on line 16 16 of Fig. 15 looking toward the left in said figure.

Like numerals refer to like parts throughout the several views of the drawings.

In the drawings, 20 is a supporting-block formed of insulating material and formed in two parts 21 and 22. A transverse passage 23 extends entirely across the supporting-block 20, opening out of opposite sides thereof. Said transverse passage is formed by two passages, a passage 24 formed in the under side of the part 21 and a passage 25 formed in the upper side of the part 22. The circuit-controlling key 26 is located in the transverse passage 23, a portion thereof being located in the passage 24 and a portion in the passage 25. Said key consists of a shaft 27, having a handle 28 fast to one end thereof, and a rotary contact-block 29 loosely mounted upon the opposite end thereof in a manner well known to those skilled in the art, with a lost motion between said block and shaft. The shaft 27 is rotatably mounted in bearings 30, provided in the opposite ends of a bearing-plate 31. The bearing-plate 31 has an arm 32 thereon which is provided with a binding-screw 33 by means of which one of the wires 34 is attached to said bearing-plate. The arm 32 is located in a recess 35, provided in and extending part way around the periphery of the supporting-block 20, and the circuit-wire 34 passes through a recess 36, extending from the recess 35 upwardly to the top of the block 20.

The bearing-plate 31 has one of its free ends bent to form a flange 37, and this flange is fastened by a screw 38, Fig. 6, to the part 22 of the supporting-block 20. Said bearing-plate is also fastened by a screw 39 to the upper part 21 of said supporting-block. It will be understood that both of the screws 38 and 39 are fast to the bearing-plate, at one end thereof adjacent to the handle 28, for an object hereinafter set forth.

A flat spring 40, located in the transverse passage 23, is fastened at one end thereof to the under side of the bearing-plate 31, the free end of said spring bearing against the rotary contact-block 29. A U-shaped plate 41, fastened to the under side of the lower part 22 of the supporting-block 20, is provided with a spring-arm 42, extending upwardly and turning backwardly therefrom and contacting with the contact-block 29 when said block is turned to the position shown in Figs. 3 and 6. Said U-shaped plate forms the outer contact-plate and contacts with the outer terminal of the lamp when the same is attached to the socket, as hereinafter described. When a Thomson-Houston incandescent lamp is used and screwed thereto, a central contact-post 43 is supplied, upon which said lamp is screwed in a manner well known to those skilled in this art, said post making contact with the central contact-terminal of the lamp.

The contact-post 43 is fast to a U-shaped contact-plate 44, which extends transversely of the key 26 and is fastened at its free ends to the upper part 21 of the supporting-block 20 by screws 45 45. Said contact-plate is located in an auxiliary passage 46, formed in the lower part 22 of the supporting-block 20, and the free ends 47 48 thereof are turned inwardly and project into recesses 49 and 50, respectively, formed in the under side of the part 21, so that, as shown in Fig. 7, insulated walls are interposed between the said ends 47 48 and the bearing-plate 31. Two halves 21 22 of the porcelain or other insulating-block are constructed so as to meet or abut against each other, as shown in the drawings, or as nearly so as the exigencies of practical manufacture will permit, so as to inclose and protect the metallic parts constituting the two branches of the circuit in two insulating-chambers, one of which is the passage 23 and the other of which is the transverse passage 46. These two chambers, transverse to each other, are separated from each other except where the lower part of the passage 23 may be said to cross the upper part of the passage 46. An ear 51, formed upon the contact-plate 44, receives a second binding-screw 52, to which a second circuit-wire 53 is fastened. The upper and lower parts 21 and 22 are provided with a recess 54 to receive the ear 51, and a recess 55 is provided in the periphery of the upper part 21 for the reception of the circuit-wire 53, which passes upwardly from the binding-screw 52.

A metal shell 56 surrounds the supporting-block and the parts carried thereby and is fastened by screws to a plate 57, fast to the upper part 21. Between the shell 56 and the supporting-block 20 an insulating-lining is provided, said shell and lining being held against displacement with relation to each other by an inwardly-extending projection 59, struck up on said shell and projecting inwardly therefrom into an indentation 60,

formed in the exterior of said lining. By this construction the lining and shell are held firmly together, said indentation being of sufficient depth to hold the two against relative displacement and not being deep enough so but that the lining may be sprung sufficiently to be forced into the interior of the shell to a point where said projection will spring into said indentation.

When an incandescent-lamp socket of a form similar to the Thomson-Houston lamp, well known to those skilled in this art, is screwed upon the screw-threaded contact-post 43 and the circuit-controlling key is turned to the position shown in Figs. 3 and 6, the current passes from the wire 34 through the key-shaft 27 and rotary contact-block 29, through the outer contact-plate 41, thence to the outer terminal of the lamp, passing through said lamp to the inner terminal to the central contact-post 43, and from said post through the U-shaped plate 44 to the binding-screw 52, fast to said plate and to the second circuit-wire 53. The circuit is broken by turning the circuit-controlling key from the position shown in Figs. 3 and 6 to that shown in Figs. 1 and 2.

It will be noted that the spring 40 is attached to the bearing-plate 31 and that the bearing-plate 31 is fastened, by the screws 38 and 39 at the end thereof adjacent to the handle 28 and farthest from the contact-block 29, to the supporting-block 20, the object of this construction being to obtain a yielding support for the key-shaft 27, so that when said key-shaft is being turned from the position shown in Fig. 2 to that shown in Figs. 3 and 6 the springs 40 and 42 will both yield and the bearing-plate 31 will also yield under sufficient pressure and spring upwardly, thus adding to the efficiency of the device and to the length of life of the springs 40 and 42, as compared with a device in which the spring 40 is supported upon a rigidly-supported bearing-plate.

In Fig. 14 I have illustrated a modified form of socket, adapted to have attached thereto an Edison incandescent lamp with a screw-thread provided upon the periphery of a shell 61, fastened to the lower part of the supporting-block and contacting with the U-shaped contact-plate 41, while the central contact-post 43' terminates in a cylindrical flange arranged to bear against the central contact-terminal of the lamp.

While I have used in certain portions of the specification and hereinafter in the claims the term "upper" and "lower" parts as relating to the two parts of which the supporting-block 20 is formed, it is evident that such terms are simply relative and are used for the purpose of more clearly describing the device, as the lamp may be inverted and the lower part would then become the upper part, or vice versa, without departing from the spirit of my invention.

Having thus described my invention, what I claim, and desire by Letters Patent to secure, is—

1. An incandescent-lamp socket, comprising in its construction a supporting-block of insulating material in two parts, a circuit-controlling key, a plate having bearings in its opposite ends for said key, the plate being fastened at one end thereof to both of said parts, and springs to act on said key near the other end.

2. An incandescent-lamp socket, comprising in its construction a supporting-block of insulating material formed in two parts which meet each other, a chamber in said parts extending thereacross, a circuit-controlling key and a bearing-plate therefor located in said chamber, a second chamber transverse to the first, and a U-shaped contact-plate in the second chamber and secured to both parts of the insulating-block.

3. An incandescent-lamp socket, comprising in its construction a supporting-block of insulating material formed in two parts which meet each other, a chamber in said parts extending thereacross, a circuit-controlling key and a bearing-plate therefor located in said chamber, a transverse chamber in one of said parts, and two recesses in the other part, a U-shaped contact-plate in said transverse chamber, and secured therein and also secured at its free ends in the said recesses.

4. An incandescent-lamp socket, compris-

ing a supporting-block in two parts which meet each other, and containing two insulating-chambers transverse to each other, one chamber containing the metallic parts forming one branch of the circuit and the other containing the metallic parts forming the other branch of the circuit.

5. An incandescent-lamp socket, comprising a supporting-block in two parts which meet each other, and containing two insulating-chambers transverse to each other, a key in one of the chambers, a U-shaped contact-plate in the other of the chambers having connection with the central lamp-contact in the lower part and having its free ends secured in recesses in the upper part.

6. An incandescent-lamp socket, comprising a supporting-block in two parts which meet each other, and containing two insulating-chambers transverse to each other, a key in one of the chambers and a U-shaped contact-plate in the other, the U-shaped contact-plate having inwardly-turned free ends secured in recesses in the upper part of the insulating-block.

In testimony whereof I have hereunto set my hand in presence of two subscribing witnesses.

GUY H. PROCTOR.

Witnesses:

CHARLES S. GOODING,
ANNIE J. DAILEY.