

T. G. STILES.
DETECTOR BAR CLIP AND LINK.

APPLICATION FILED FEB. 21, 1903.

NO MODEL.

2 SHEETS—SHEET 1.

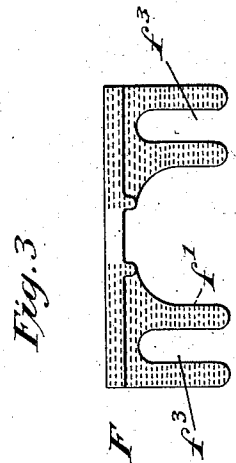
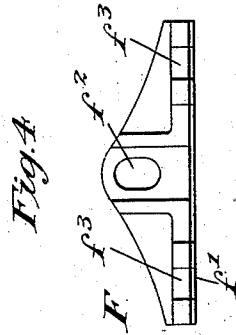
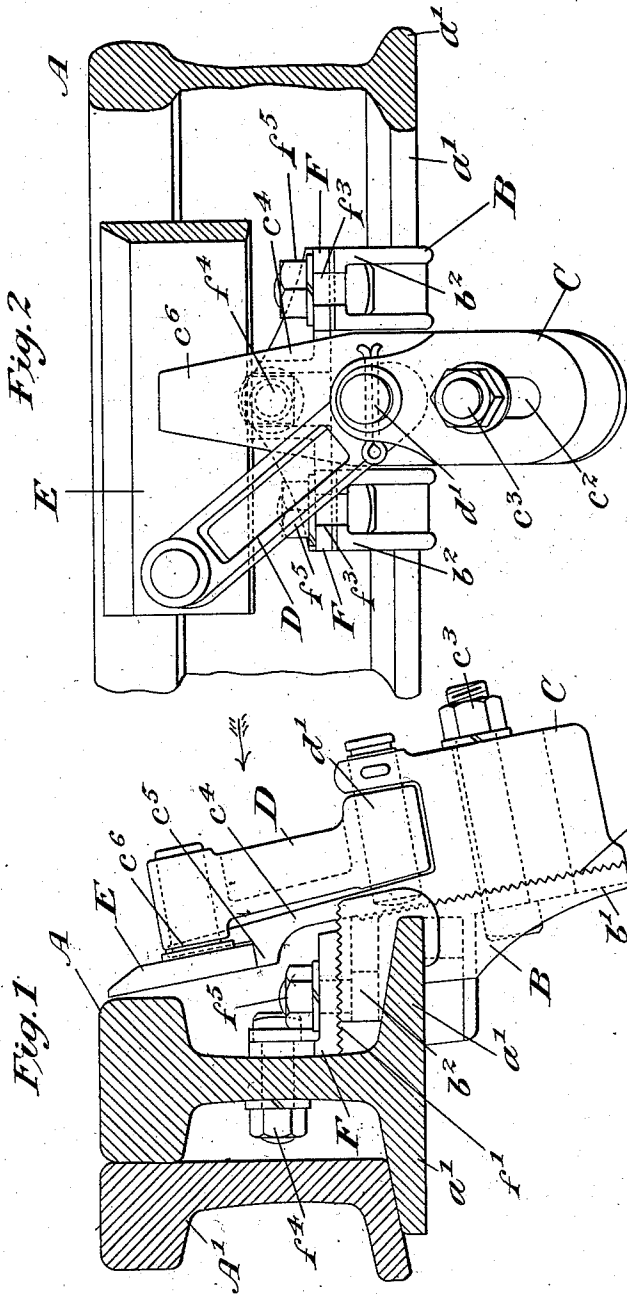

Witnesses
Chas. B. King,
William A. Dorman

Inventor
T. George Stiles
 By *his* Attorney
J. V. Peck

T. G. STILES.
DETECTOR BAR CLIP AND LINK.

APPLICATION FILED FEB. 21, 1903.

NO MODEL.

2 SHEETS—SHEET 2.

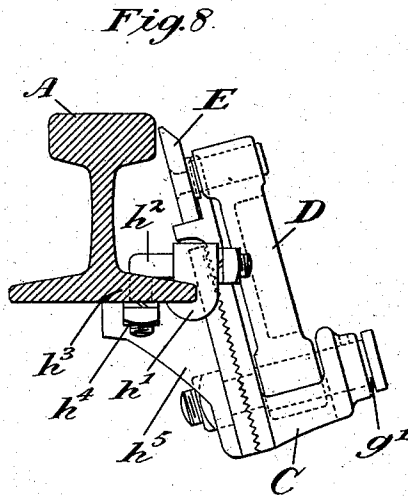
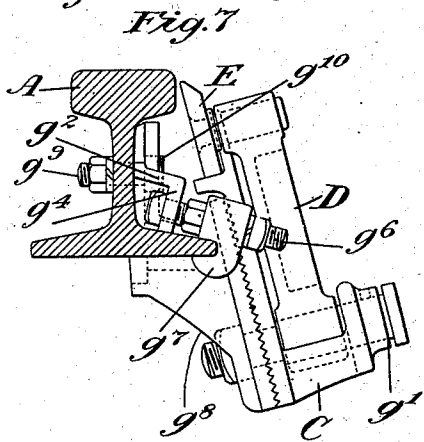
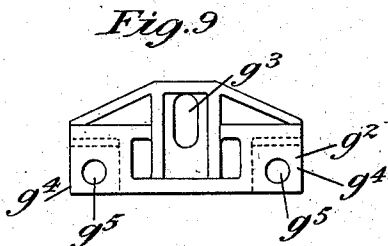
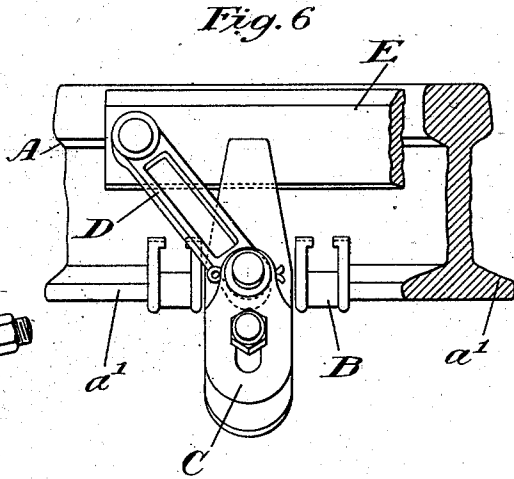
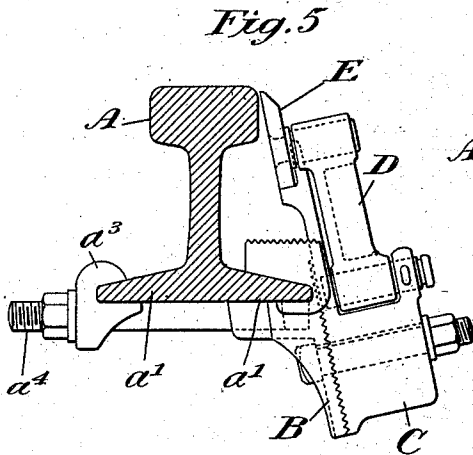

Witnesses
Chas. R. King
William R. Norman

Inventor
T. George Stiles
 By his Attorney
Wm. V. Deeken

UNITED STATES PATENT OFFICE.

THOMAS GEO. STILES, OF ARLINGTON, NEW JERSEY.

DETECTOR-BAR CLIP AND LINK.

SPECIFICATION forming part of Letters Patent No. 748,229, dated December 29, 1903.

Application filed February 21, 1903. Serial No. 144,468. (No model.)

To all whom it may concern:

Be it known that I, THOMAS GEORGE STILES, a citizen of the United States of America, and a resident of Arlington, in the county of Hudson and State of New Jersey, have invented certain new and useful Improvements in Detector-Bar Clips and Links, of which the following is a specification.

My invention relates generally to detector-bar clips and links, and is more particularly an improvement upon the invention disclosed in Letters Patent No. 548,323.

In the above patent is shown a clip and a link, the latter having an adjustable fulcrum upon the former, the clip being secured in position on the rail by a device which embraces both side flanges of the said rail. This fastening device cannot be used immediately in the rear of a switch, as another rail is superposed upon one of the side flanges of the rail proper. One object of my invention is to overcome this difficulty.

In the said patent previously referred to the link, as noted above, is adjustably fulcrumed upon the clip and carries two wings which act as a stop for limiting the throw of the bar. This construction is not a desirable one, as all the thrust when the bar is thrown falls upon the bolt which connects the link and the bar with each other, and thus tends to loosen the parts, which in time causes the detector-bar to be pushed outward when it encounters the wheels of a car passing over the tracks, thereby defeating the object of the whole mechanism. To overcome this obstacle, is another object of my invention.

I shall describe a detector-bar clip and link embodying my invention and afterward point out the novel features in the claims.

In the drawings I have shown my invention embodied in several forms, but do not wish to be understood as limiting myself to these, as changes may be made without departing from the spirit of my invention.

In the said drawings, Figure 1 represents a transverse section of a rail having another rail superposed on one of its side flanges and showing also a clip, link, and detector-bar embodying my invention in position on the other side flange of the rail. Fig. 2 is a side view of Fig. 1 looking in the direction of the arrow. Figs. 3 and 4 are detail views of an

angle-plate for attaching the clip to the rail. Figs. 5 and 6 are views similar to Figs. 1 and 2, showing the clip attached to the rail by the ordinary means. Figs. 7 and 8 show modifications. Fig. 9 is a detail view of the angle-plate used in the modification shown in Fig. 7.

Similar letters of reference indicate corresponding parts in the different views.

Referring first to Figs. 1, 2, 3, and 4, A indicates a rail, and A' an additional rail superposed upon one of the side flanges *a'* of the rail A. B is a clip embracing the other side flange *a'* and provided with a downwardly-projecting portion *b'*, transversely indented, and with a horizontal portion *b²* above the flange *a'* of the rail, indented longitudinally of the said rail. C is a bracket whose inner surface *c'* is indented to correspond with the indentations on the portion *b'* of the clip. This bracket further has an oblong slot *c²*, through which the bolt *c³* passes and by means of which it is secured to the clip, so that it can be adjusted to any desired height vertically. D is a link mounted on the bracket C by means of the stud *d'*, and consequently adjustable with the bracket with relation to the clip, thereby making its fulcrum adjustable. At its upper end the link D is attached to the detector-bar E. The bracket C further carries an upwardly-extending portion *c⁴*, having a horizontal ledge *c⁵*, forming a stop for the detector-bar, and having an uppermost portion *c⁶* forming a guide for the detector-bar. It will be understood that the said stop and guide are mounted on the bracket independently of the link, but that they are adjustable with the said bracket, and consequently with the link. When the bar is thrown, it is raised up from the stop *c⁵* and moving in an arc of a circle will drop again on the said stop at the end of its stroke, which stop thus takes all the thrust. At the same time while the bar is being thrown the guide *c⁶* will prevent it from moving outward and away from under the car-wheels. F indicates an angle-plate provided with indentations *f'*, corresponding to the indentations on the horizontal portion *b²* and provided, further, with the slots *f²* and *f³*. By this means it will be observed that the angle-plate F can be adjusted on the horizontal portion *b²* to suit the various sizes of rails. Bolts, as

f^4 and f^5 f^5 , secure the angle-plate to the rail and to the clip, the bolt f^4 passing through the slot f^2 and the web a^2 of the rail, while the bolts f^5 f^5 pass through the slots f^3 f^3 and into the clip. By this means the clip can be attached so as to embrace but one side flange a' of the rail, so as not to interfere with the superposed rail on the other flange a' .

In Figs. 5 and 6 the ordinary fastening means is shown, an additional shoe a^3 , embracing the other flange a' , being used, one or more bolts, as a^4 , connecting the shoe and the clip. In this instance, of course, the angle-plate F is dispensed with.

In Figs. 7 and 9 is shown one modification in which a bolt g' serves both to fasten the bracket to the clip and the link to the bracket. In this instance also an angle-plate g^2 is used, having the oblong slot g^3 adjacent to the rail and two projections g^4 , having holes g^5 . Adjustable screws g^6 , only one of which is seen, pass through the embracing portion g^7 of the clip g^8 and through the holes g^5 of the angle-plate g^2 , whereby the distance can be regulated, while a bolt g^9 passes through the web of the rail into the oblong slot g^3 and into a removable head g^{10} .

In Fig. 8 the embracing portion h' of the clip h^5 is provided with angle-bolts h^2 , only one of which is seen, passing through the side flange h^3 of the rail and secured there by means of the nuts h^4 .

Having thus described my invention, what I claim is—

1. The combination with a detector-bar and a rail-clip, of a link attached to the bar and adjustably fulcrumed upon the rail-clip, and a stop and guide, limiting and guiding the throw of the bar, both adjustable with the link but not moving with the same when the bar is thrown.

2. The combination with a detector-bar, and a rail-clip, of a bracket vertically adjustable on the clip, a link mounted on said bracket and attached to the bar, and a stop and guide limiting and guiding the throw of the bar, both carried independently of the link by the

bracket aforesaid and adjustable with the latter.

3. The combination with a rail having another rail superposed on one of its side flanges, and a clip for adjustably supporting a link and detector-bar, of means for securing the said clip in position on the other side flange of the rail.

4. The combination with a rail, and a clip, for adjustably supporting a link and detector-bar, embracing one of the side flanges of the rail, of a horizontal portion on said clip above the flange of the rail having indentations running longitudinally of the rail, an angle-plate indented to correspond with the indentations on the clip adjustably secured to the rail and to the clip.

5. The combination with a rail, and a clip, for adjustably supporting a link and detector-bar, embracing one of the side flanges of the rail, of a horizontal portion on said clip above the flange of the rail having indentations running longitudinally of the rail, an angle-plate indented to correspond with the indentations on the clip, oblong slots on the angle-plate adjacent to the rail and to the clip, and bolts passing through said slots securing the angle-plate to the rail and to the clip.

6. The combination with a rail having another rail superposed on one of its side flanges, and a clip for adjustably supporting a link and detector-bar, of adjustable means for securing the said clip on the other side flange of the rail.

7. The combination with a rail, and a clip, for adjustably supporting a link and detector-bar, embracing one of the side flanges of the rail, of adjustable means attached to the web of the rail for securing the clip in position.

Signed at New York this 11th day of February, 1903.

T. GEO. STILES.

Witnesses:

WILLIAM R. DORMAN,
AXEL V. BEEKEN.