

(No Model.)

E. H. GOODWIN.  
CAR COUPLING.

No. 265,406.

Patented Oct. 3, 1882.

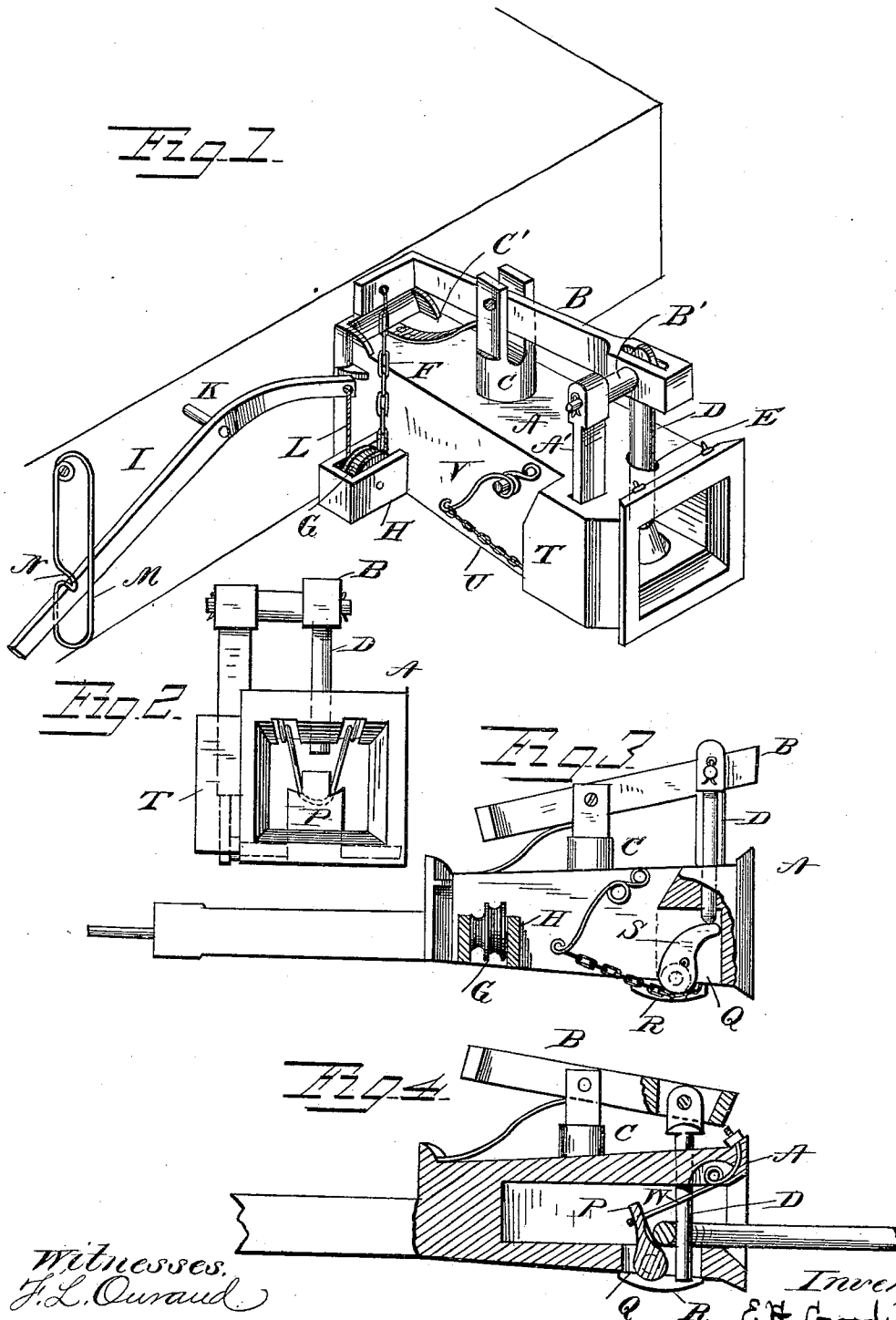

Witnesses.  
*J. L. Ouraud*  
*Jas. L. Falby.*

Inventor.  
*E. H. Goodwin*  
By *H. J. Dennis*  
*Atty.*

# UNITED STATES PATENT OFFICE.

ELI H. GOODWIN, OF ANTONE, KANSAS.

## CAR-COUPLING.

SPECIFICATION forming part of Letters Patent No. 265,406, dated October 3, 1882.

Application filed June 13, 1882. (No model.)

*To all whom it may concern:*

Be it known that I, ELI H. GOODWIN, a citizen of the United States, residing at Antone, in the county of Pawnee and State of Kansas, have invented certain new and useful Improvements in Car-Couplers, of which the following is a specification, reference being had had therein to the accompanying drawings.

This invention relates to certain improvements in car-couplers; and it has for its objects to provide for automatically coupling the cars when they come together and for uncoupling them without necessitating the entrance of a person between the cars for the purpose, as more fully hereinafter specified. These objects I attain by the means illustrated in the accompanying drawings, in which—

Figure 1 represents a perspective view of a portion of the frame of a car, showing my coupling applied thereto. Fig. 2 represents a front view of a draw-head, showing my coupling mechanism. Fig. 3 represents a view, partly in side elevation and partly in section, of a draw-head having my coupling devices applied thereto; and Fig. 4 represents a longitudinal vertical section of the draw-head and coupling devices.

The letter A indicates a draw-head, which has the usual flaring mouth, and which is secured to the car-frame in the usual or any approved manner.

B indicates a lever fulcrumed in a bearing, C, on the top of the draw-head. At its forward end the lever is slotted, and in said slot is pivoted the upper end of a coupling-pin, D, which sits through an opening, E, in the draw-head. The rear of the lever is bent at a right angle, and has attached to it a chain, F, which passes over a pulley, G, journaled in a box, H, secured to or cast with the draw-head.

The letter I indicates a lever fulcrumed at K to the car and connected with the pulley G by means of a chain, L. The said lever extends to the side of the car, its free end passing through a bracket, M, which is provided with a detent, N, to hold the lever, as more fully hereinafter specified.

The letter P indicates a dog or pawl located in an opening, Q, in the lower part of the draw-head and pivoted in bearings R. The said pawl has secured to one of its journals a pawl, S, which is adapted to play in a box, T, at one side of the draw-head. To the said pawl is secured one end of a chain, U, the other end

of which is secured to a spring, V, which serves to hold and return the pawl to a normal position.

W indicates a spring-link, which catches and holds the pawl P when the coupling-pin is up.

The letter A' indicates a bar secured to an extension, B', at one side of the forward end of the lever B, and extending downward through an opening in the top of the box T, its lower end being adapted to rest upon the top of the pawl S to hold the coupling-pin in an elevated position, as indicated in Fig. 3 of the drawings.

The operation of my invention is as follows: The coupling-pin is elevated by means of the lever I, which is secured under the detent of the bracket. When thus elevated the spring V throws the pawls in the position shown in Fig. 3. When the coupling-link enters as the cars come together the pawls are thrown back, permitting the pin to drop through the link, and thus couple the cars. The coupling-pin lever has a spring, C', under its rear end, by which it is caused to throw the pin into place when released.

Having thus described my invention, what I claim, and desire to secure by Letters Patent, is—

1. The combination, with the draw-head, of the lever carrying the coupling-pin, the pulley to which said lever is connected by means of a chain, the elevating-lever connected to said pulley by means of a chain, and the bracket and its detent for holding the levers and the pin, substantially as specified.

2. In combination with the lever carrying the coupling-pin, the vertical rod attached to an extension thereon and extending into a box at the side of the draw-head, and the pawls and spring for holding and returning the same to a normal position, substantially as specified.

3. The combination of the lever carrying the coupling-pin, the pawls and spring for holding and returning the same to normal position, the vertical rod attached to the lever carrying the coupling-pin, and the spring-link adapted to engage the inner pawl, the whole arranged to operate substantially as specified.

In testimony whereof I affix my signature in presence of two witnesses.

ELI H. GOODWIN.

Witnesses:  
FRED HAG,  
JAMES P. DAVIS.