



(43) International Publication Date
24 December 2014 (24.12.2014)

(51) International Patent Classification:
A21B 1/48 (2006.01)

(21) International Application Number:
PCT/US2014/042516

(22) International Filing Date:
16 June 2014 (16.06.2014)

(25) Filing Language: English

(26) Publication Language: English

(30) Priority Data:
61/835,747 17 June 2013 (17.06.2013) US

(71) Applicant: W.C BRADLEY CO. [US/US]; 1017 Front Street, Columbus, GA 31904 (US).

(72) Inventor: AHMED, Mallik; 1517 Ridge Creek Way, Columbus, GA 31904 (US).

(74) Agent: BROWN, Dennis, D.; Brown Patent Law, P.L.L.C., 2700 N. Hemlock Ct., Suite 111 E, Broken Arrow, OK 74012 (US).

(81) Designated States (unless otherwise indicated, for every kind of national protection available): AE, AG, AL, AM, AO, AT, AU, AZ, BA, BB, BG, BH, BN, BR, BW, BY, BZ, CA, CH, CL, CN, CO, CR, CU, CZ, DE, DK, DM, DO, DZ, EC, EE, EG, ES, FI, GB, GD, GE, GH, GM, GT,

HN, HR, HU, ID, IL, IN, IR, IS, JP, KE, KG, KN, KP, KR, KZ, LA, LC, LK, LR, LS, LT, LU, LY, MA, MD, ME, MG, MK, MN, MW, MX, MY, MZ, NA, NG, NI, NO, NZ, OM, PA, PE, PG, PH, PL, PT, QA, RO, RS, RU, RW, SA, SC, SD, SE, SG, SK, SL, SM, ST, SV, SY, TH, TJ, TM, TN, TR, TT, TZ, UA, UG, US, UZ, VC, VN, ZA, ZM, ZW.

(84) Designated States (unless otherwise indicated, for every kind of regional protection available): ARIPO (BW, GH, GM, KE, LR, LS, MW, MZ, NA, RW, SD, SL, SZ, TZ, UG, ZM, ZW), Eurasian (AM, AZ, BY, KG, KZ, RU, TJ, TM), European (AL, AT, BE, BG, CH, CY, CZ, DE, DK, EE, ES, FI, FR, GB, GR, HR, HU, IE, IS, IT, LT, LU, LV, MC, MK, MT, NL, NO, PL, PT, RO, RS, SE, SI, SK, SM, TR), OAPI (BF, BJ, CF, CG, CI, CM, GA, GN, GQ, GW, KM, ML, MR, NE, SN, TD, TG).

Declarations under Rule 4.17:

- as to the identity of the inventor (Rule 4.17(i))
- as to applicant's entitlement to apply for and be granted a patent (Rule 4.17(ii))

Published:

- with international search report (Art. 21(3))

[Continued on next page]

(54) Title: HIGH EFFICIENCY APPARATUS AND METHOD FOR COOKING, HEATING AND DRYING

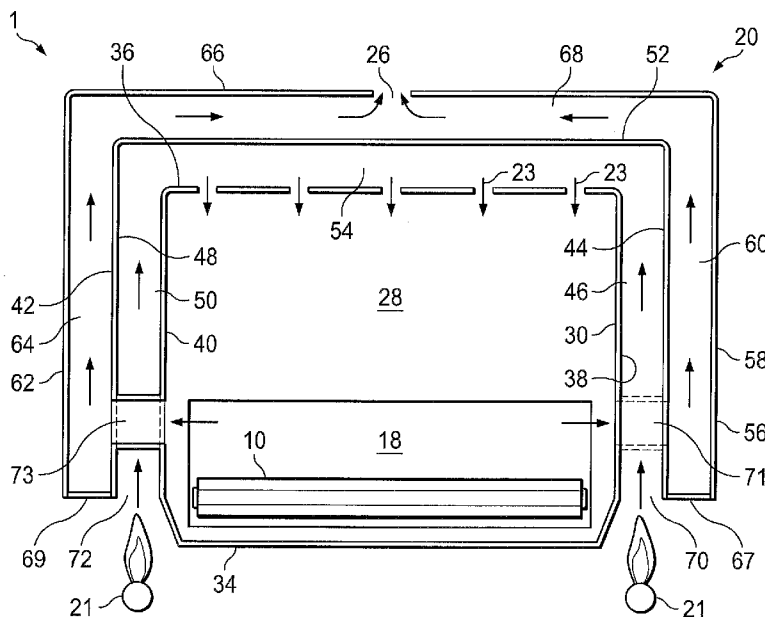

FIG. 2

(57) Abstract: An apparatus and method for cooking, heating, or drying in which, as items or materials are conveyed through a heating chamber by a linear, spiral, or other type of conveyor, hot combustion product gases are delivered upwardly through an upwardly extending first annulus or other flow gap which is closest to the conveyor. The hot combustion product gases are then delivered downwardly through the heating chamber into contact with the items or materials on the conveyor. Next the combustion product gases are delivered from the lower portion of the heating chamber into the lower portion of a second annulus or other flow gap or passage. The second flow gap or passage is separated from the heating chamber by the first annulus or other flow gap. Subsequently, the combustion product gases are delivered upwardly through the second flow gap or passage.

WO 2014/204848 A1

- *before the expiration of the time limit for amending the claims and to be republished in the event of receipt of amendments (Rule 48.2(h))*

HIGH EFFICIENCY APPARATUS AND METHOD FOR COOKING, HEATING AND DRYING

Field of the Invention

5 [0001] The present invention relates to combustion-type apparatuses and methods for cooking food products and for heating and/or drying other items and materials.

Background of the Invention

[0002] A need exists for improved linear, tunnel-type, box-type, spiral, and other industrial combustion (e.g., gas) ovens and oven systems for cooking food items, or for
10 heating and/or drying other items or materials, as the items or materials are continuously, semi-continuously, or intermittently delivered through the oven. A need also exists for a means of significantly reducing temperature differences and substantially eliminating the presence of cold and/or hot pockets within these combustion-type systems.

Summary of the Invention

15 [0003] The present invention provides a combustion-type apparatus and method for cooking food items, or for heating and/or drying items or materials of any other type, which satisfy the needs and alleviate the problems discussed above. The inventive apparatus and method improve the energy efficiency of the cooking, heating, and/or drying process to a degree which is both surprising and unexpected. In addition, a much
20 more uniform temperature profile is provided within the inventive apparatus during operation and hot and cold pockets within the apparatus are substantially eliminated.

[0004] In one aspect, the inventive apparatus preferably comprises a housing having:
(1) upwardly extending left and right side interior walls; (2) a heating chamber (i.e., a chamber for cooking, warming, and/or drying food products or other items or materials)
25 defined between the left and right side interior walls; (3) upwardly extending left and right side outer walls respectively positioned outwardly from the left and right side interior walls; (4) an upwardly extending left side intermediate wall positioned between the left side interior and outer walls; (5) an upwardly extending left side inner combustion product gas flow gap formed between the left side interior and intermediate walls; (6) an
30 upwardly extending left side outer combustion product gas flow gap formed between the left side intermediate and outer walls; (7) an upwardly extending right side intermediate wall positioned between the right side interior and outer walls; (8) an upwardly extending right side inner combustion product gas flow gap formed between the right side interior

and intermediate walls; and (9) an upwardly extending right side outer combustion product gas flow gap formed between the right side intermediate and outer walls.

5 [0005] The inventive apparatus preferably also comprises one or more fuel burners positioned to deliver a combustion product gas into the lower end portions of the left and right side inner combustion product gas flow gaps. In addition, the left and right side inner combustion product gas flow gaps preferably have upper end portions which are in fluid communication with an upper portion of the heating chamber to deliver the combustion product gas from of the upper end portions of the left and right side inner combustion product gas flow gaps into the upper portion of the heating chamber.

10 [0006] Further, the housing preferably also includes a plurality of outwardly extending side flow passages located in a lower portion of the heating chamber which place the lower portion of the heating chamber in fluid communication with the lower portions of the left and right side outer combustion product gas flow gaps for delivering the combustion product gas from the lower portion of the heating chamber to the lower end portions of the left and right side outer combustion product gas flow gaps.

15 [0007] In another aspect, there is provided an apparatus for cooking, heating or drying comprising: a housing; a heating chamber within the housing for cooking, heating, or drying; a conveyor extending through the heating chamber; an upwardly extending first wall of the housing; an upwardly extending interior heating chamber wall of the housing inside of the upwardly extending first wall, wherein the upwardly extending interior heating chamber wall faces the conveyor; an upwardly extending intermediate wall of the housing between the upwardly extending first wall and the upwardly extending interior heating chamber wall; an upwardly extending inner flow gap which is formed between the upwardly extending interior heating chamber wall and the upwardly extending intermediate wall; an upwardly extending outer flow gap which is formed between the upwardly extending intermediate wall and the upwardly extending first wall; and a flow path defined in the housing for combustion products, wherein the flow path travels through the upwardly extending inner flow gap, the heating chamber, and the upwardly extending outer flow gap.

20
25
30 [0008] In another aspect, this apparatus can further comprise a plurality of flow ducts located at a lower portion of the heating chamber which extend outwardly through the upwardly extending inner flow gap to place the lower portion of the heating chamber in fluid communication with a lower portion of the upwardly extending outer flow gap.

[0009] In another aspect, the flow path defined in the housing of this apparatus for the combustion products can preferably travel upwardly through the upwardly extending inner flow gap, then downwardly through the heating chamber, then outwardly through the flow ducts from the lower portion of the heating chamber to the lower portion of the upwardly extending outer flow gap, and then upwardly through the upwardly extending outer flow gap.

[0010] In another aspect, this apparatus can comprise identical or substantially identical wall and flow gap structures and identical or substantially preferred flow paths as described above on both the left side and the right side of a linear or other conveyor.

[0011] In another alternative aspect of this apparatus, the conveyor can be a spiral conveyor wherein the upwardly extending inner flow gap and the upwardly extending outer flow gap will preferably surround the heating chamber and the spiral conveyor in a horizontal plane. Also, the apparatus can further optionally include (i) a flow annulus which extends upwardly through a central portion of the heating chamber, wherein the spiral conveyor is outside of and winds around the flow annulus and (ii) a flow passage which extends upwardly through and is surrounded by, but is different from, the flow annulus such that the flow path defined in the housing for combustion products also travels through the central flow annulus and the central flow passage.

[0012] In another aspect, there is provided an apparatus for cooking, heating or drying comprising: a housing; a heating chamber within the housing for cooking, heating, or drying; a flow annulus which extends upwardly through a central portion of the heating chamber; a flow passage which extends upwardly through and is surrounded by, but is different from, the flow annulus; a conveyor which winds vertically within the heating chamber outside of and around the flow annulus; and a flow path defined in the housing for combustion products, wherein the flow path travels through the flow annulus, the heating chamber, and the flow passage. Preferably, the flow path defined in the housing for the combustion products travels upwardly through the flow annulus, then downwardly through the heating chamber, then inwardly through a plurality of flow ducts extending inwardly from the lower portion of the heating chamber to the lower portion of the flow passage, and then upwardly through the flow passage.

[0013] In another aspect, there is provided a method of cooking, heating or drying items or materials comprising the steps of: (a) conveying the items or materials, using a conveyor, through a heating chamber with a housing; (b) heating an upwardly extending right side inner wall within the housing facing the right side of the conveyor by delivering

a first portion of a combustion product flow upwardly through an upwardly extending right side inner flow gap formed between the upwardly extending right side inner wall and an upwardly extending second right side wall positioned outside of the upwardly extending right side inner wall; (c) heating an upwardly extending left side inner wall within the housing facing the left side of the conveyor by delivering a second portion of the combustion product flow upwardly through an upwardly extending left side inner flow gap formed between the upwardly extending left side inner wall and an upwardly extending second left side wall positioned outside of the upwardly extending left side inner wall; (d) delivering the first and the second portions of the combustion product flow from upper portions of the upwardly extending right side and left side inner flow gaps into an upper portion of the heating chamber to form a combined combustion product flow; (e) delivering the combined combustion product flow downwardly through the heating chamber; (f) delivering a first portion of the combined combustion product flow from a lower portion of the heating chamber into a lower portion of an upwardly extending right side outer flow gap formed between the upwardly extending right side second wall and an upwardly extending right side third wall positioned outside of the upwardly extending right side second wall and delivering a second portion of the combined combustion product flow from the lower portion of the heating chamber into a lower portion of an upwardly extending left side outer flow gap formed between the upwardly extending left side second wall and an upwardly extending left side third wall positioned outside of the upwardly extending left side second wall; and (g) delivering the first and the second portions of the combined combustion product flow upwardly through the upwardly extending right side and left side outer flow gaps.

[0014] In another aspect, there is provided a method of cooking, heating or drying items or materials comprising the steps of: (a) conveying the items or materials vertically through a heating chamber in a spiral pattern using a spiral conveyor; (b) delivering combustion products upwardly through an upwardly extending inner flow gap formed between an upwardly extending inner wall and an upwardly extending second wall positioned outside of the upwardly extending inner wall, wherein the upwardly extending inner wall faces the spiral conveyor and surrounds the spiral conveyor in a horizontal plane and the upwardly extending inner flow gap surrounds the spiral conveyor in the horizontal plane; (c) delivering the combustion products from an upper portion of the upwardly extending inner flow gap into an upper portion of the heating chamber; (d) delivering the combustion products downwardly through the heating chamber; (e)

delivering the combustion products from a lower portion of the heating chamber into a lower portion of an upwardly extending outer flow gap formed between the upwardly extending second wall and an upwardly extending third wall positioned outside of the upwardly extending second wall, wherein the upwardly extending outer flow gap surrounds the spiral conveyor in the horizontal plane; and then (f) delivering the combustion products upwardly through the upwardly extending outer flow gap.

[0015] In additional optional aspects of this method: step (b) can further comprise delivering an additional amount of combustion products upwardly through a flow annulus which extends upwardly through a central portion of the heating chamber, wherein the spiral conveyor is outside of and winds around the flow annulus; step (c) can further comprise delivering the additional amount of combustion products from an upper portion of the flow annulus into the upper portion of the heating chamber; step (e) can further comprise delivering at least a portion of the additional amount of combustion products from the lower portion of the heating chamber into a lower portion of a flow passage which extends upwardly through and is surrounded by, but is different from, the flow annulus; and step (f) can further comprise delivering the portion of the additional amount of combustion products upwardly through the flow passage.

[0016] In another aspect, there is provided a method of cooking, heating or drying items or materials comprising the steps of: (a) conveying the items or materials vertically through a heating chamber in a spiral pattern using a spiral conveyor; (b) delivering combustion products upwardly through a flow annulus which extends upwardly through a central portion of the heating chamber, wherein the spiral conveyor is outside of and winds around the flow annulus; (c) delivering the combustion products from an upper portion of the flow annulus into an upper portion of the heating chamber; (d) delivering the combustion products downwardly through the heating chamber; (e) delivering the combustion products from a lower portion of the heating chamber into a lower portion of a flow passage which extends upwardly through and is surrounded by, but is different from, the flow annulus; and then (f) delivering the combustion products upwardly through the flow passage. In step (e), the combustion products are preferably delivered through a plurality of flow ducts which extend inwardly through the flow annulus from the lower portion of the heating chamber to the lower portion of the flow passage.

[0017] In another aspect, to provide an increase percentage of convective heat transfer and/or increased browning, the method of cooking, heating or drying can be modified, for example, to comprise the steps of: (a) conveying the items or materials, using a conveyor,

through a heating chamber within a housing; (b) heating an upwardly extending first wall within the housing facing the conveyor by delivering a first portion of a combustion product flow upwardly through an upwardly extending first flow gap formed between the upwardly extending first wall and an upwardly extending second wall spaced apart from the upwardly extending first wall; (c) delivering the first portion of the combustion product flow from an upper end portion of the upwardly extending first flow gap into an upper end portion of the heating chamber; (d) delivering a second portion of the combustion product flow from the upwardly extending first flow gap into the heating chamber through a plurality of apertures provided through the upwardly extending first wall; (e) delivering the first and the second portions of the combustion product flow downwardly through the heating chamber; (f) delivering the first and second portions of the combustion product flow as a combined combustion product flow from a lower end portion of the heating chamber into a lower end portion of an upwardly extending second flow gap formed between the upwardly extending second wall and an upwardly extending third wall spaced apart from the upwardly extending second wall; and then (g) delivering the combined combustion product flow upwardly through the upwardly extending second flow gap.

[0018] In this modified method, the number and size of the apertures provided through the upwardly extending first wall will preferably be such that the second portion of the combustion product flow will be less than or equal to the first portion of the combustion product flow on a weight basis. More preferably, the second portion of the combustion product flow will not be more than one half of the first portion of the combustion product flow on a weight basis. The apertures or can be provided through the upwardly extending first wall in any pattern desired.

[0019] In another aspect, there is provided a method of cooking, heating or drying items or materials comprising the steps of: (a) conveying the items or materials, using a conveyor, through a heating chamber within a housing; (b) heating an upwardly extending first wall within the housing facing the conveyor by delivering a combustion product flow upwardly through an upwardly extending first flow gap formed between the upwardly extending first wall and an upwardly extending second wall spaced apart from the upwardly extending first wall; (c) delivering the combustion product flow from an upper end portion of the upwardly extending first flow gap into an upper end portion of the heating chamber; (d) delivering the combustion product flow downwardly through the heating chamber; (f) delivering the combustion product flow from a lower end portion of

the heating chamber into a lower end portion of an upwardly extending second flow gap formed between the upwardly extending second wall and an upwardly extending third wall spaced apart from the upwardly extending second wall; and then (g) delivering the combustion product flow upwardly through the upwardly extending second flow gap.

5 [0020] Further aspects, features, and advantages of the present invention will be apparent to those of ordinary skill in the art upon examining the accompanying drawings and upon reading the following Detailed Description of the Preferred Embodiments.

Brief Description of the Drawings

10 [0021] Figure 1 is a perspective view of a linear, tunnel-type embodiment 1 of the inventive cooking, heating, and/or drying apparatus.

[0022] Figure 2 is a cut-away elevational front end view of the inventive apparatus 1.

[0023] Figure 3 is a cut-away elevational view of a spiral embodiment 100 of the inventive cooking, heating, and/or drying apparatus.

15 [0024] Figure 4 is a cut-away top view of the inventive spiral cooking, heating, and/or drying apparatus 100.

[0025] Figure 5 is a cut-away top view of an alternative spiral embodiment 200 of the inventive cooking, heating, and/or drying apparatus.

Detailed Description of the Preferred Embodiments

20 [0026] An embodiment 1 of the combustion-type cooking, heating, and/or drying apparatus provided by the present invention is illustrated in Figures 1 and 2. By way of example, but not by way of limitation, the inventive apparatus 1 shown in Figs. 1 and 2 is a linear industrial tunnel-type oven which comprises: an elongate horizontal housing 20 having a heating chamber 28 therein, the heating chamber 28 having a front (inlet) end opening 16 and a rear (outlet) end opening 18; a conveyor 10 which enters the inlet end opening 16, runs through the elongate internal heating chamber 28, and exits the outlet end opening 18; and one or more burners 21 for generating a combustion product gas for heating the inventive apparatus 1.

25 [0027] The elongate horizontal housing 20 comprises an elongate, horizontally extending interior heating chamber box 30 which has an approximately rectangular cross-sectional shape and which surrounds or substantially surrounds the heating chamber 28 in the vertical cross-sectional plane 32. The heating chamber box 30 extends longitudinally from the inlet end 27 to the outlet end 29 of the oven housing 20.

30 [0028] In the lateral cross-sectional view provided in Figure 2, the heating chamber box 30 comprises: a horizontal bottom wall 34 beneath the conveyor 10; a horizontal top

wall 36 which is spaced above the conveyor 10; an upwardly extending right side wall 38 positioned adjacent the right side of the conveyor 10; an upwardly extending left side wall 40 positioned adjacent the left side of the conveyor 10; and a plurality of combustion product gas flow openings 23 formed through the horizontal top wall 36. The gas flow openings 23 in the horizontal top wall 36 will preferably be provided along most, and more preferably along at least 80%, of the longitudinal length of the housing 20.

[0029] The elongate housing 20 further comprises an elongate, horizontally extending intermediate shell 42 which is positioned over the interior heating chamber box 30. The intermediate shell 42 preferably extends horizontally from the inlet end 27 to the outlet end 29 of the oven housing 20. In the lateral cross-sectional view provided in Figure 2, the intermediate shell 42 comprises: (a) an upwardly extending right side wall 44 which is spaced outwardly apart from the right side wall 38 of the interior heating chamber box 30 such that an upwardly extending right side inner combustion product gas flow gap 46 is formed between the right side interior and intermediate walls 38 and 44; (b) an upwardly extending left side wall 48 which is spaced outwardly apart from the left side wall 40 of the interior heating chamber box 30 such that an upwardly extending left side inner combustion product gas flow gap 50 is formed between the left side interior and intermediate walls 40 and 48; and (c) a horizontal top wall 52 which is spaced upwardly apart from the horizontal top wall 36 of the interior heating chamber box 30 such that a top horizontal inner combustion product gas flow gap 54 is formed between the top interior and intermediate walls 36 and 52.

[0030] In addition, the elongate housing 20 further comprises an elongate, horizontally extending outer shell 56 which is positioned over the intermediate shell 42. The outer shell 56 preferably extends horizontally from the inlet end 27 to the outlet end 29 of the oven housing 20. In the lateral cross-sectional end view provided in Figure 2, the elongate outer shell 56 comprises: (a) an upwardly extending right side wall 58 which is spaced outwardly apart from the right side wall 44 of the intermediate shell 42 such that an upwardly extending right side outer combustion product gas flow gap 60 is formed between the right side intermediate and outer walls 44 and 58; (b) an upwardly extending left side wall 62 which is spaced outwardly apart from the left side wall 48 of the intermediate shell 42 such that an upwardly extending left side outer combustion product gas flow gap 64 is formed between the left side intermediate and outer walls 48 and 62; (c) a horizontal top wall 66 which is spaced upwardly apart from the horizontal top wall 52 of the intermediate shell 42 such that a top horizontal outer combustion product gas

flow gap **68** is formed between the top intermediate and outer walls **52** and **66**; and (d) one or more combustion product gas exhaust openings **26** which are preferably provided in the top horizontal wall **66** of the elongate outer shell **56**.

[0031] The bottoms **67** and **69** of the outer combustion product gas flow gaps **60** and **64** on the right and left sides of the apparatus **1** are preferably closed. In addition, a series of right side flow ducts **71** and a series of left side flow ducts **73** are provided in the bottom portion of the heating chamber **28**. The flow ducts **71** and **73** extend outwardly through the right and left interior side walls **38** and **40** and through the right and left intermediate side walls **44** and **48** to place the bottom portion of the heating chamber **28** in fluid communication with the bottom end portions of the outer combustion product gas flow gaps **60** and **64** on the right and left sides of the inventive apparatus **1**.

[0032] The burners **21** used in the inventive apparatus **1** can be any type of burner capable of delivering a hot combustion product gas into the open bottom ends **70** and **72** of the right and left side inner gas flow gaps **46** and **50**. The burners **21** will preferably be gas or liquid burners and will most preferably be operable for burning a gas fuel. In addition, the burners **21** will preferably be either (1) line burners or (2) pipe burners having a series of ports or nozzles extending along the top thereof for discharging a combustion fuel or for discharging a fuel and air mixture. The burners **21** will preferably extend longitudinally on the left and right sides of the inventive apparatus **1** either beneath or within the open bottom ends **70** and **72** of the right and left side inner combustion product gas flow gaps **46** and **50**. Further, it will also be understood that smoke (e.g., wood smoke) from a smoke generator or other source can optionally be added to the combustion product gas produced by the burners **21**.

[0033] The conveyor **10** used in the inventive apparatus **1** can be any type of open, closed, or semi-open conveyor belt suitable for delivering the food products or other items or materials in question through the inventive apparatus **1** for cooking, heating, and/or drying. In addition, although a belt-type conveyor **10** is illustrated in Figure 2, it will be understood that other types of conveyors can alternatively be used in the inventive apparatus **1**. By way of example, but not by way of limitation, the conveyor could alternatively be (a) a chain-type conveyor from which the items could be hung and carried in suspension as they are delivered through the heating chamber **28**, (b) a wire mesh conveyor, or (c) a spiral conveyor.

[0034] Further, it will also be understood that the inventive apparatus **1** and the conveyor **10** can be operable for (a) continuously delivering a stream of items or

materials through the heating chamber **28** at a constant conveyor speed, (b) delivering an individual item or batch of items or materials into stationary position within the heating chamber **28** and then removing the item or batch from the apparatus **1** when the cooking, heating, and/or drying operation is completed, or (c) delivering streams or batches of items or materials through the heating chamber **28** on generally any other variable speed or intermittent/start-stop basis.

[0035] During operation, the hot combustion product gas produced by the burners **21** flows into the open lower ends **70** and **72** of the inner combustion product gas flow gaps **46** and **50** on the right and left sides of the apparatus **1**. As the hot combustion product gas flows upwardly through the right and left inner flow gaps **46** and **50**, it heats the outer surfaces of the right and left side walls **38** and **40** of the interior heating chamber box **30** so that infrared radiant energy is emitted from the inner surfaces of the right and left side walls **38** and **40** of the interior heating chamber box **30** into the heating chamber **28**. The hot combustion product gas then flows out of the upper ends of the inner gas flow gaps **46** and **50** and into the horizontal inner gas flow gap **54** in the top of the inventive apparatus **1**. The flow of the combustion product gas through the top inner flow gap **54** also heats the outer surface of the horizontal top wall **36** of the interior heating chamber box **30** so that infrared radiant energy is emitted from the top interior wall **36** into the heating chamber **28**.

[0036] Next, the gas is delivered via the combustion product gas flow openings **23** in the horizontal top wall **36** of the interior heating chamber box **30** into the upper portion of the heating chamber **28**. Subsequently, the combustion product gas flows downwardly through the heating chamber **28**, wherein it contacts the food products or other items or materials on the conveyor **10**. The combustion product gas then flows outwardly through the side flow ducts **71** and **73** located in the bottom of the heating chamber **28** and into the lower ends of the outer combustion product gas flow gaps **60** and **64** on the right and left sides of the apparatus **1**.

[0037] As the combustion product gas then flows upwardly through the right and left outer flow gaps **60** and **64**, it increases the operating temperature of the right and left intermediate side walls **44** and **48**. Finally, when the combustion product gas reaches the upper ends of the right and left outer flow gaps **60** and **64**, the combustion product gas is discharged to the atmosphere via the top horizontal outer gas flow gap **68** and the top exhaust opening(s) **26**.

[0038] The flow of the combustion product gas upwardly through the inner gas flow gaps 46 and 50, downwardly through the heating chamber 28, and then upwardly through the outer gas flow gaps 60 and 64 operates to extract significantly more heat from the combustion product gas as compared to other prior art combustion-type systems. This is achieved in the inventive apparatus 1 by (a) retaining the combustion product gas in the apparatus 1 for a significantly longer period of time and (b) heating not only the outer surfaces of the right and left side walls 38 and 40 of the interior heating chamber box 30 surrounding the heating chamber 28, but also warming the left and right intermediate walls 44 and 48 and directly contacting and heating the food products or other items or materials in the heating chamber 28.

[0039] Moreover, the operational heat recovery and efficiency of the inventive apparatus 1 are further enhanced by the intentional selection and combination of the preferred upward and downward flow paths of the combustion product gas through the right and left side inner flow gaps 46 and 50, the heating chamber 28, and the right and left side outer flow gaps 60 and 64. As the hot combustion product gas flows upwardly through the inner flow gaps 46 and 50, it is traveling in classic counter-current heat exchange relationship with the cooler combustion product gas flowing downwardly through the heating chamber 28, thus increasing the transfer of heat into the heating chamber 28. However, the upward flow of the hot combustion product gas through the right and left inner flow gaps 46 and 50 is in parallel relationship with the upward flow of the cooler combustion product gas traveling through the right and left outer gaps 60 and 64 so that the outward transmission (i.e., loss) of heat from the inner vertical gas flow gaps 46 and 50 to the outer vertical gas flow gaps 60 and 64 is reduced.

[0040] In addition, the extended flow path of the combustion product gas through the inventive apparatus 1 increases the backpressure at the burners 21 by an amount sufficient to provide a beneficial reduction in the amount of excess air which flows into the apparatus 1.

[0041] Further, food products prepared in the inventive system 1 retain significantly more moisture than food products cooked in prior art combustion-type convective systems. This is because (a) from about 65% to about 75% of the cooking energy transmitted to the food products in the inventive apparatus 1 will be in the form of infrared radiant energy, (b) as a result of having to first heat the right and left side walls 38 and 40 of the interior heating chamber box 30 before entering the heating chamber 28, the temperature of the combustion product gas in the inventive apparatus 1 will have been

reduced to a more desirable level (i.e., typically a low heat to high heat cooking range of from about 200° to about 600° F) before contacting the food products, and (c) a gentler, lower volume convective flow regime is achieved in the heating chamber 28 of the inventive apparatus 2 by reducing both the volume of excess air and the amount of fuel used in the combustion process.

[0042] It is also noted concerning the more gentle flow and operation of the combustion product gas through the heating chamber 28 that as a result of having already given up energy in heating the side walls 38 and 40 and the top wall 36 of the heating chamber box 30, the convective flow velocity of the combustion product gas through the heating chamber 28 will be further reduced. In addition, the lower velocity of the combustion product gas reduces the convective heat transfer coefficient and thereby reduces the convective heat transfer to the objects carried by the conveyor 10 through the inventive apparatus 1 so that the ratio of infrared heating energy transferred to the objects versus convective energy can be further increased.

[0043] Although the embodiment 1 of the inventive apparatus illustrated in Figs. 1 and 2 has a rectangular cross-sectional shape, it will be understood that rounded, cylindrical, or other cross-sectional shapes can alternatively be used. In addition, it will be understood that the location, size, configuration, and/or arrangement of any or all of the interior gas flow openings 23, ducts 71 and 73, and exhaust opening(s) 26 can be varied as desired to (a) facilitate, increase, or slow the flow of the combustion product gas through the inventive apparatus 1 and/or (b) alter or optimize the balance of infrared and convective heat transfer occurring within the heating chamber 28.

[0044] Also, the outer shell 56 of the inventive apparatus 1 can be insulated to further reduce heat loss and thus further increase the energy efficiency of the inventive system. Further, one or more fans can be installed on the apparatus exhaust or at the burner air intake to increase the heat output of the burners 21 and/or boost or facilitate the circulation of the combustion product gas through the inventive system. Additionally, for spiral oven applications or for any other form of the inventive apparatus, the inner and outer combustion product gas flow channels can alternatively be provided on three or four vertical sides of the heating chamber or can otherwise be configured to extend partially around, substantially entirely around, or entirely around the heating chamber in a horizontal plane extending through the heating chamber, and/or in a vertical plane extending through the heating chamber.

[0045] An alternative embodiment **100** of the inventive combustion-type cooking, heating, and/or drying apparatus is illustrated in Figures 3 and 4. The inventive apparatus **100** is an industrial spiral oven comprising: a cylindrical vertical housing **120** having a vertically-extending heating chamber **128** therein, the heating chamber **128** having a lower inlet opening **116** and an upper outlet opening **118**; a spiral conveyor **110** which enters the lower inlet opening **116**, travels upwardly in a spiral pattern through the vertically extending heating chamber **128**, and exits the upper outlet opening **118**; and one or more burners **121** for generating a combustion product gas for heating the inventive apparatus **100**.

10 [0046] The vertical cylindrical housing **120** comprises a vertically extending interior cylindrical heating chamber wall **130** which surrounds the heating chamber **128** in the horizontal cross-sectional plane **132**. The interior heating chamber wall **130** extends vertically from an elevation below the conveyor inlet opening at **116** to an elevation above the conveyor outlet opening **118**.

15 [0047] The vertically extending heating chamber **128** further comprises: a horizontal or downwardly concave bottom wall **134** at an elevation beneath the conveyor inlet opening **116**; a horizontal or upwardly concave top wall **136** at an elevation above the conveyor outlet opening **118**; and a plurality of combustion product gas flow openings **123** formed through the top wall **136**.

20 [0048] The cylindrical housing **120** of the inventive apparatus **100** further comprises an intermediate shell **142** which includes an upwardly extending cylindrical wall **144**. The intermediate cylindrical wall **144** is spaced outwardly apart from the cylindrical interior wall **130** of the heating chamber **128** such that an upwardly extending, cylindrical, inner combustion product gas flow annulus **146** is formed between the vertical interior wall **130** and the vertical intermediate wall **144**. The vertical inner combustion product gas flow annulus **146** surrounds the heating chamber **128** in the horizontal plane **132** and extends from an elevation below the conveyor inlet opening **116** to an elevation above the conveyor outlet opening **118**.

25 [0049] The intermediate shell **142** further comprises a downwardly concave or frusto-conical bottom wall **148** and a horizontal or upwardly concave top wall **152**. The bottom wall **148** of the intermediate shell **142** is spaced downwardly apart from the interior heating chamber bottom wall **134** to form a combustion chamber **155** in which the burner(s) **121** is/are housed. The top wall **152** of the intermediate shell **142** is spaced upwardly apart from the top interior heating chamber wall **136** such that a top inner

combustion product gas flow gap **154** is formed between the top interior and intermediate walls **136** and **152**.

[0050] In addition, the vertical cylindrical housing **120** of the spiral apparatus **100** also comprises an outer shell **156** which includes an upwardly extending cylindrical wall **158**. The outer cylindrical wall **158** is spaced outwardly apart from the cylindrical intermediate wall **144** of the intermediate shell **142** such that an upwardly extending, cylindrical, outer combustion product gas flow annulus **160** is formed between the vertical intermediate wall **144** and the vertical outer wall **158**. The vertical outer combustion product gas flow annulus **160** surrounds both the heating chamber **128** and the inner vertical gas flow annulus **146** in the horizontal plane **132**.

[0051] The outer vertical flow annulus **160** extends from an elevation below the conveyor inlet opening **116** to an elevation above the conveyor outlet opening **118**. The outer shell **156** further comprises a horizontal or upwardly concave top wall **166** which is spaced upwardly apart from the top wall **152** of the intermediate shell **142** such that a top outer combustion product gas flow gap **168** is formed between the top intermediate and outer walls **152** and **166**. One or more combustion product gas exhaust openings **126** are preferably provided in the top wall **166** of the outer shell **156**.

[0052] The bottom end **167** of the outer combustion product gas flow annulus **160** is preferably closed. In addition, a series of flow ducts **171** is provided in the bottom portion of the heating chamber **128**. The flow ducts **171** extend radially outward through the interior vertical heating chamber wall **138** and the vertical intermediate wall **144** to place the bottom portion of the heating chamber **128** in fluid communication with the bottom end of the outer combustion product gas flow annulus **160**. The series of flow ducts **171** preferably surrounds the lower portion of the heating chamber **128**.

[0053] The burner(s) **121** used in the inventive apparatus **100** can be any type of burner capable of producing a hot combustion product gas in the combustion chamber **155** for delivery by the combustion chamber **155** into the lower end of the inner vertical combustion product gas flow annulus **146**. Alternatively, however, the burner **121** can, for example, be a ring burner which is positioned directly below or within the open bottom end **170** of the inner vertical combustion product gas flow annulus **146**.

[0054] Each burner **121** will preferably be a gas or liquid burner and will most preferably be operable for burning a gas fuel. It will also be understood that smoke (e.g., wood smoke) from a smoke generator or other source can optionally be added to the combustion product gas produced by the burner(s) **121**.

[0055] The conveyor **110** used in the inventive apparatus **100** can be any type of wire or other open, closed, or semi-open spiral conveyor or conveyor belt suitable for delivering the food products or other items or materials in question through the inventive apparatus **100** for cooking, heating, and/or drying.

5 [0056] During operation, the hot combustion product gas produced by the burner(s) **121** flows into the open lower end **170** of the inner gas flow annulus **146** of the apparatus **100**. As the hot combustion product gas flows upwardly through the inner flow annulus **146**, it heats the outer surface of the cylindrical interior heating chamber wall **130** so that infrared radiant energy is emitted from the inner surface of the vertical interior wall **130**
10 into the heating chamber **128**. The hot combustion product gas then flows out of the upper end of the inner combustion product gas flow annulus **146** and into the inner combustion product gas flow gap **154** in the top of the inventive apparatus **100**. The flow through the top inner flow gap **154** heats the outer surface of the top interior wall **136** so that infrared radiant energy can also be emitted from the top interior wall **136** into the
15 heating chamber **128**.

[0057] Next, the combustion product gas is delivered via the flow openings **123** in the top interior wall **136** into the upper portion of the heating chamber **128**. Subsequently, the combustion product gas flows downwardly through the heating chamber **128**, wherein it contacts the food products or other items or materials on the spiral conveyor **110**. The
20 combustion product gas then flows radially outward through the flow ducts **171** located in the bottom of the heating chamber **128** and into the lower end of the outer cylindrical combustion product gas flow annulus **160** of the apparatus **100**.

[0058] As the combustion product gas then flows upwardly through outer cylindrical flow annulus **160** it increases the operating temperature of the cylindrical intermediate
25 wall **144**. Finally, when the combustion product gas reaches the upper end of the outer flow annulus **160**, the combustion product gas is discharged to the atmosphere via the top outer combustion product gas flow gap **168** and the top exhaust opening(s) **126**.

[0059] Although the embodiment **100** of the inventive spiral heating apparatus illustrated in Figures 3 and 4 comprises only a single pair of concentric exterior inner and
30 outer combustion product gas flow annuli **146** and **160** which surround the heating chamber **128**, it will be understood that a pair of concentric cylindrical gas flow annuli could alternatively be provided within the central column **175** of the spiral heating apparatus **100** such that infrared radiant heating energy is emitted from the outer surface of the central column **175** into the heating chamber **128**.

[0060] Moreover, as illustrated in the alternative embodiment **200** shown in Figure 5, the inventive spiral heating apparatus can be equipped with both (a) the same concentric exterior combustion product gas flow annuli **146** and **160** surrounding the heating chamber **128** as used in apparatus **100** and (b) a second pair of concentric, cylindrical, upwardly extending combustion product gas flow annuli **202** and **204** within the central column **175**. A plurality of flow ducts **205** extend radially inward through the central flow annulus **202** which is closest to the heating chamber **128** to place the lower end portion of the heating chamber **128** in fluid communication with the lower end portion of the central flow annulus **204** which is within, and extends upwardly through, the flow annulus **202**.

[0061] As will be apparent, in each case, regardless of whether the concentric flow annuli are located around the exterior of the heating chamber **128** or within the central column **175**, the combustion product gas will preferably first flow upwardly through the annulus closest to the heating chamber **128** and then will subsequently flow upwardly through the annulus furthest from the heating chamber **128** after flowing downwardly through the heating chamber **128** itself.

[0062] Consequently, in the inventive spiral apparatus **200** illustrated in Figure 5, a combustion product gas produced in or below the bottom of the apparatus **200** will first flow upwardly through both (a) the flow annulus **146** as described for apparatus **100** and (b) the annulus **202** within the central column **175** which is closest to the heating chamber **128**. Next, the combustion product gas from annulus **146** and annulus **202** will flow downwardly through the heating chamber **128**. Then the combustion product gas will simultaneously flow (a) outwardly via the flow ducts **171** from the lower portion of the heating chamber **128** into the lower end portion of outer flow annulus **160** as described for apparatus **100** and (b) inwardly via the flow ducts **205** from the lower portion of the heating chamber **128** into the lower end portion of the annulus **204** within the central column **175** which is furthest from the heating chamber **128**. Next, the combustion product gas will flow upwardly through both the flow annulus **160** and the annulus **204**.

[0063] It will be understood by those in the art that for any spiral, linear, or other configuration of the inventive cooking, heating, and/or drying apparatus, baffles, flaps, fans, insulation, and/or other elements or structures known in the art can be used to prevent or at least significantly reduce the loss of the hot combustion products from the conveyor inlet and outlet openings and the loss of heat from the apparatus in general.

[0064] It will also be understood by those in the art that each of the inventive cooking, heating, and/or drying apparatuses 1, 100, and 200 can include any type of desired operating and control system, instruments, sensors, manual controls, automatic controls, etc. known in the art for: monitoring temperatures within the heating chamber
5 and/or at any other desired location within the unit; monitoring the temperatures of the items or materials being heated; setting, adjusting, and/or controlling the movement and speed of the conveyor; setting, adjusting, and/or controlling temperatures or combustion or fuel rates; igniting the burners; etc.

[0065] Thus, the present invention is well adapted to carry out the objects and attain
10 the ends and advantages mentioned above as well as those inherent therein. While presently preferred embodiments have been described for purposes of this disclosure, numerous changes and modifications will be apparent to those of ordinary skill in the art. Such changes and modifications are encompassed within this invention as defined by the claims.

15

The Claims

What is claimed is:

1. An apparatus for cooking, heating or drying comprising:
 - a housing;
 - 5 a heating chamber within the housing for cooking, heating, or drying;
 - a conveyor extending through the heating chamber;
 - an upwardly extending first wall of the housing;
 - an upwardly extending interior heating chamber wall of the housing inside of the
upwardly extending first wall, wherein the upwardly extending heating
10 chamber wall faces the conveyor;
 - an upwardly extending intermediate wall of the housing between the upwardly
extending first wall and the upwardly extending interior heating chamber
wall;
 - an upwardly extending inner flow gap which is formed between the upwardly
15 extending interior heating chamber wall and the upwardly extending
intermediate wall;
 - an upwardly extending outer flow gap which is formed between the upwardly
extending intermediate wall and the upwardly extending first wall; and
 - a flow path defined in the housing for combustion products, wherein the flow path
20 travels through the upwardly extending inner flow gap, the heating
chamber, and the upwardly extending outer flow gap.
2. The apparatus of claim 1 further comprising a plurality of flow ducts located at a
lower portion of the heating chamber which extend outwardly through the upwardly
extending inner flow gap to place the lower portion of the heating chamber in fluid
25 communication with a lower portion of the upwardly extending outer flow gap.
3. The apparatus of claim 2 wherein the flow path defined in the housing for the
combustion products travels upwardly through the upwardly extending inner flow
gap, then downwardly through the heating chamber, then outwardly through the flow
ducts from the lower portion of the heating chamber to the lower portion of the
30 upwardly extending outer flow gap, and then upwardly through the upwardly
extending outer flow gap.
4. The apparatus of claim 3 further comprising at least one fuel burner for producing the
combustion products, the fuel burner being in fluid communication with a lower
portion of the upwardly extending inner flow gap.

5. The apparatus of claim 1 wherein the upwardly extending first wall, the upwardly extending interior heating chamber wall, and the upwardly extending intermediate wall of the housing extend longitudinally adjacent to a right side of the conveyor, the upwardly extending inner flow gap is an upwardly extending right side inner flow gap which extends longitudinally adjacent to the right side of the conveyor, the upwardly extending outer flow gap is an upwardly extending right side outer flow gap which extends longitudinally adjacent to the right side inner flow gap, and the apparatus further comprises:

an upwardly extending interior left side heating chamber wall of the housing which faces and extends longitudinally adjacent to a left side of the conveyor;

an upwardly extending intermediate left side wall of the housing which extends longitudinally outside of and adjacent to the upwardly extending interior left side heating chamber wall;

an upwardly extending first left side wall of the housing which extends longitudinally outside of and adjacent to the upwardly extending intermediate left side wall;

an upwardly extending left side inner flow gap which is formed between the upwardly extending interior left side heating chamber wall and the upwardly extending intermediate left side wall and extends longitudinally adjacent to the left side of the conveyor;

an upwardly extending left side outer flow gap which is formed between the upwardly extending intermediate left side wall and the upwardly extending first left side wall; and

said flow path defined in the housing for combustion products travels through the upwardly extending right side and left side inner flow gaps, the heating chamber, and the upwardly extending right side and left side outer flow gaps.

6. The apparatus of claim 5 further comprising

a plurality of right side flow ducts located at a lower portion of the heating chamber which extend outwardly through the upwardly extending right side inner flow gap to place the lower portion of the heating chamber in fluid communication with a lower portion of the upwardly extending right side outer flow gap and

a plurality of left side flow ducts located at a lower portion of the heating chamber which extend outwardly through the upwardly extending left side inner flow gap to place the lower portion of the heating chamber in fluid communication with a lower portion of the upwardly extending left side outer flow gap.

5

7. The apparatus of claim 6 wherein the flow path defined in the housing for the combustion products travels upwardly through the upwardly extending right side and left side inner flow gaps, then downwardly through the heating chamber, then outwardly through the right side and left side flow ducts from the lower portion of the heating chamber to the lower portions of the upwardly extending right side and left side outer flow gaps, and then upwardly through the upwardly extending right side and left side outer flow gaps.

10

8. The apparatus of claim 7 further comprising one or more fuel burners for producing the combustion products, the one or more fuel burners being in fluid communication with a lower portion of the upwardly extending right side inner flow gap and a lower portion of the upwardly extending left side inner flow gap.

15

9. The apparatus of claim 1 wherein the conveyor is a spiral conveyor.

10. The apparatus of claim 9 wherein the upwardly extending inner flow gap and the upwardly extending outer flow gap surround the heating chamber and the spiral conveyor in a horizontal plane.

20

11. The apparatus of claim 10 further comprising a plurality of flow ducts located at a lower portion of the heating chamber which extend outwardly through the upwardly extending inner flow gap to place the lower portion of the heating chamber in fluid communication with a lower portion of the upwardly extending outer flow gap.

25

12. The apparatus of claim 11 wherein the flow path defined in the housing for the combustion products travels upwardly through the upwardly extending inner flow gap, then downwardly through the heating chamber, then outwardly through the flow ducts from the lower portion of the heating chamber to the lower portion of the upwardly extending outer flow gap, and then upwardly through the upwardly extending outer flow gap.

30

13. The apparatus of claim 12 further comprising at least one fuel burner for producing the combustion products, the fuel burner being in fluid communication with a lower portion of the upwardly extending inner flow gap.

14. The apparatus of claim 9 further comprising:

a flow annulus which extends upwardly through a central portion of the heating chamber, wherein the spiral conveyor winds outside of and around the flow annulus;

5 a flow passage which extends upwardly through and is surrounded by, but is different from, the flow annulus; and

the flow path defined in the housing for combustion products also travels through the flow annulus and the flow passage.

15. The apparatus of claim 14 further comprising:

10 a plurality of outer flow ducts located at a lower portion of the heating chamber which extend outwardly through the upwardly extending inner flow gap to place the lower portion of the heating chamber in fluid communication with a lower portion of the upwardly extending outer flow gap and

15 a plurality of inner flow ducts located in the lower portion of the heating chamber which extend inwardly through the flow annulus to place the lower portion of the heating chamber in fluid communication with a lower portion of the flow passage.

16. The apparatus of claim 15 wherein the flow path defined in the housing for the combustion products travels upwardly through both the upwardly extending inner flow gap and the flow annulus, then downwardly through the heating chamber, then both outwardly through the outer flow ducts from the lower portion of the heating chamber to the lower portion of the upwardly extending outer flow gap and inwardly through the inner flow ducts from the lower portion of the heating chamber to the lower portion of the flow passage, and then both upwardly through the upwardly extending outer flow gap and upwardly through the flow passage.

17. An apparatus for cooking, heating or drying comprising:

a housing;

a heating chamber within the housing for cooking, heating, or drying;

30 a flow annulus which extends upwardly through a central portion of the heating chamber;

a flow passage which extends upwardly through and is surrounded by, but is different from, the flow annulus;

a conveyor which winds vertically within the heating chamber outside of and around the flow annulus; and

a flow path defined in the housing for combustion products, wherein the flow path travels through the flow annulus, the heating chamber, and the flow passage.

5 18. The apparatus of claim 17 further comprising a plurality of flow ducts located in a lower portion of the heating chamber which extend inwardly through the flow annulus to place the lower portion of the heating chamber in fluid communication with a lower portion of the flow passage.

10 19. The apparatus of claim 18 wherein the flow path defined in the housing for the combustion products travels upwardly through the flow annulus, then downwardly through the heating chamber, then inwardly through the flow ducts from the lower portion of the heating chamber to the lower portion of the flow passage, and then upwardly through the flow passage.

20. A method of cooking, heating or drying items or materials comprising the steps of:

15 (a) conveying the items or materials, using a conveyor, through a heating chamber within a housing;

20 (b) heating an upwardly extending right side inner wall within the housing facing the right side of the conveyor by delivering a first portion of a combustion product flow upwardly through an upwardly extending right side inner flow gap formed between the upwardly extending right side inner wall and an upwardly extending second right side wall positioned outside of the upwardly extending right side inner wall;

25 (c) heating an upwardly extending left side inner wall within the housing facing the left side of the conveyor by delivering a second portion of the combustion product flow upwardly through an upwardly extending left side inner flow gap formed between the upwardly extending left side inner wall and an upwardly extending second left side wall positioned outside of the upwardly extending left side inner wall;

30 (d) delivering the first and the second portions of the combustion product flow from upper portions of the upwardly extending right side and left side inner flow gaps into an upper portion of the heating chamber to form a combined combustion product flow;

(e) delivering the combined combustion product flow downwardly through the heating chamber;

- 5 (f) delivering a first portion of the combined combustion product flow from a lower portion of the heating chamber into a lower portion of an upwardly extending right side outer flow gap formed between the upwardly extending right side second wall and an upwardly extending right side third wall positioned outside of the upwardly extending right side second wall and delivering a second portion of the combined combustion product flow from the lower portion of the heating chamber into a lower portion of an upwardly extending left side outer flow gap formed between the upwardly extending left side second wall and an upwardly extending left side third wall positioned outside of the upwardly extending left side second wall; and
- 10 (g) delivering the first and the second portions of the combined combustion product flow upwardly through the upwardly extending right side and left side outer flow gaps.

21. The method of claim 20 wherein, in step (f), the first portion of the combined combustion product flow is delivered through a plurality of right side flow ducts which extend outwardly through the upwardly extending right side inner flow gap from the lower portion of the heating chamber to the lower portion of the upwardly extending right side outer flow gap and the second portion of the combined combustion product flow is delivered through a plurality of left side flow ducts which extend outwardly through the upwardly extending left side inner flow gap from the lower portion of the heating chamber to the lower portion of the upwardly extending left side outer flow gap.

15

20

22. A method of cooking, heating or drying items or materials comprising the steps of:

- 25 (a) conveying the items or materials vertically through a heating chamber in a spiral pattern using a spiral conveyor;
- (b) delivering combustion products upwardly through an upwardly extending inner flow gap formed between an upwardly extending inner wall and an upwardly extending second wall positioned outside of the upwardly extending inner wall, wherein the upwardly extending inner wall faces the spiral conveyor and surrounds the spiral conveyor in a horizontal plane and the upwardly extending inner flow gap surrounds the spiral conveyor in the horizontal plane;
- 30 (c) delivering the combustion products from an upper portion of the upwardly extending inner flow gap into an upper portion of the heating chamber;

- (d) delivering the combustion products downwardly through the heating chamber;
- (e) delivering the combustion products from a lower portion of the heating chamber into a lower portion of an upwardly extending outer flow gap formed between the upwardly extending second wall and an upwardly extending third wall positioned outside of the upwardly extending second wall, wherein the upwardly extending outer flow gap surrounds the spiral conveyor in the horizontal plane; and then
- (f) delivering the combustion products upwardly through the upwardly extending outer flow gap.

5

10 **23.** The method of claim 22 wherein, in step (e), the combustion products are delivered through a plurality of flow ducts which extend outwardly through the upwardly extending inner flow gap from the lower portion of the heating chamber to the lower portion of the upwardly extending outer flow gap.

24. The method of claim 22 wherein:

15 step (b) further comprises delivering an additional amount of combustion products upwardly through a flow annulus which extends upwardly through a central portion of the heating chamber, wherein the spiral conveyor is outside of and winds around the flow annulus;

20 step (c) further comprises delivering the additional amount of combustion products from an upper portion of the flow annulus into the upper portion of the heating chamber;

25 step (e) further comprises delivering at least a portion of the additional amount of combustion products from the lower portion of the heating chamber into a lower portion of a flow passage which extends upwardly through and is surrounded by, but is different from, the flow annulus; and

step (f) further comprises delivering the portion of the additional amount of combustion products upwardly through the flow passage.

25. The method of claim 24 wherein, in step (e), the portion of the additional combustion products is delivered through a plurality of flow ducts which extend inwardly through the flow annulus from the lower portion of the heating chamber to the lower portion of the flow passage.

26. A method of cooking, heating or drying items or materials comprising the steps of:

- (a) conveying the items or materials vertically through a heating chamber in a spiral pattern using a spiral conveyor;

- (b) delivering combustion products upwardly through a flow annulus which extends upwardly through a central portion of the heating chamber, wherein the spiral conveyor is outside of and winds around the flow annulus;
- (c) delivering the combustion products from an upper portion of the flow annulus into an upper portion of the heating chamber;
- (d) delivering the combustion products downwardly through the heating chamber;
- (e) delivering the combustion products from a lower portion of the heating chamber into a lower portion of a flow passage which extends upwardly through and is surrounded by, but is different from, the flow annulus; and then
- (f) delivering the combustion products upwardly through the flow passage.
27. The method of claim 26 wherein, in step (e), the combustion products are delivered through a plurality of flow ducts which extend inwardly through the flow annulus from the lower portion of the heating chamber to the lower portion of the flow passage.
28. A method of cooking, heating or drying items or materials comprising the steps of:
- (a) conveying the items or materials, using a conveyor, through a heating chamber within a housing;
- (b) heating an upwardly extending first wall within the housing facing the conveyor by delivering a first portion of a combustion product flow upwardly through an upwardly extending first flow gap formed between the upwardly extending first wall and an upwardly extending second wall spaced apart from the upwardly extending first wall;
- (c) delivering the first portion of the combustion product flow from an upper end portion of the upwardly extending first flow gap into an upper end portion of the heating chamber;
- (d) delivering a second portion of the combustion product flow from the upwardly extending first flow gap into the heating chamber through a plurality of apertures provided through the upwardly extending first wall;
- (e) delivering the first and the second portions of the combustion product flow downwardly through the heating chamber;
- (f) delivering the first and second portions of the combustion product flow as a combined combustion product flow from a lower end portion of the heating chamber into a lower end portion of an upwardly extending second flow gap formed between the upwardly extending second wall and an upwardly

extending third wall spaced apart from the upwardly extending second wall;
and then

(g) delivering the combined combustion product flow upwardly through the
upwardly extending second flow gap.

- 5 **29.** The method of claim 28 wherein, in step (f), the combined combustion product flow is delivered through a plurality of flow ducts which extend through the upwardly extending first flow gap from the lower end portion of the heating chamber to the lower end portion of the upwardly extending second flow gap.
- 10 **30.** The method of claim 28 wherein the upwardly extending first flow gap and the upwardly extending second flow gap entirely surround the heating chamber in a horizontal plane.
- 31.** The method of claim 28 wherein the conveyor is a spiral conveyor which winds around the first and the second flow gaps.
- 15 **32.** The method of claim 28 wherein, in step (d), the number and size of the apertures provided through the upwardly extending first wall are such that the second portion of the combustion product flow is less than or equal to the first portion of the combustion product flow on a weight basis.
- 20 **33.** The method of claim 32 wherein the second portion of the combustion product flow is not more than one half of the first portion of the combustion product flow on a weight basis.
- 34.** A method of cooking, heating or drying items or materials comprising the steps of:
- (a) conveying the items or materials, using a conveyor, through a heating chamber within a housing;
 - 25 (b) heating an upwardly extending first wall within the housing facing the conveyor by delivering a combustion product flow upwardly through an upwardly extending first flow gap formed between the upwardly extending first wall and an upwardly extending second wall spaced apart from the upwardly extending first wall;
 - 30 (c) delivering the combustion product flow from an upper end portion of the upwardly extending first flow gap into an upper end portion of the heating chamber;
 - (d) delivering the combustion product flow downwardly through the heating chamber;

(e) delivering the combustion product flow from a lower end portion of the heating chamber into a lower end portion of an upwardly extending second flow gap formed between the upwardly extending second wall and an upwardly extending third wall spaced apart from the upwardly extending second wall; and then

5

(f) delivering the combustion product flow upwardly through the upwardly extending second flow gap.

35. The method of claim 34 wherein, in step (e), the combustion product flow is delivered through a plurality of flow ducts which extend through the upwardly extending first flow gap from the lower end portion of the heating chamber to the lower end portion of the upwardly extending second flow gap.

10

36. The method of claim 34 wherein the upwardly extending first flow gap and the upwardly extending second flow gap entirely surround the heating chamber in a horizontal plane.

15

37. The method of claim 34 wherein the conveyor is a spiral conveyor which winds around the first and the second flow gaps.

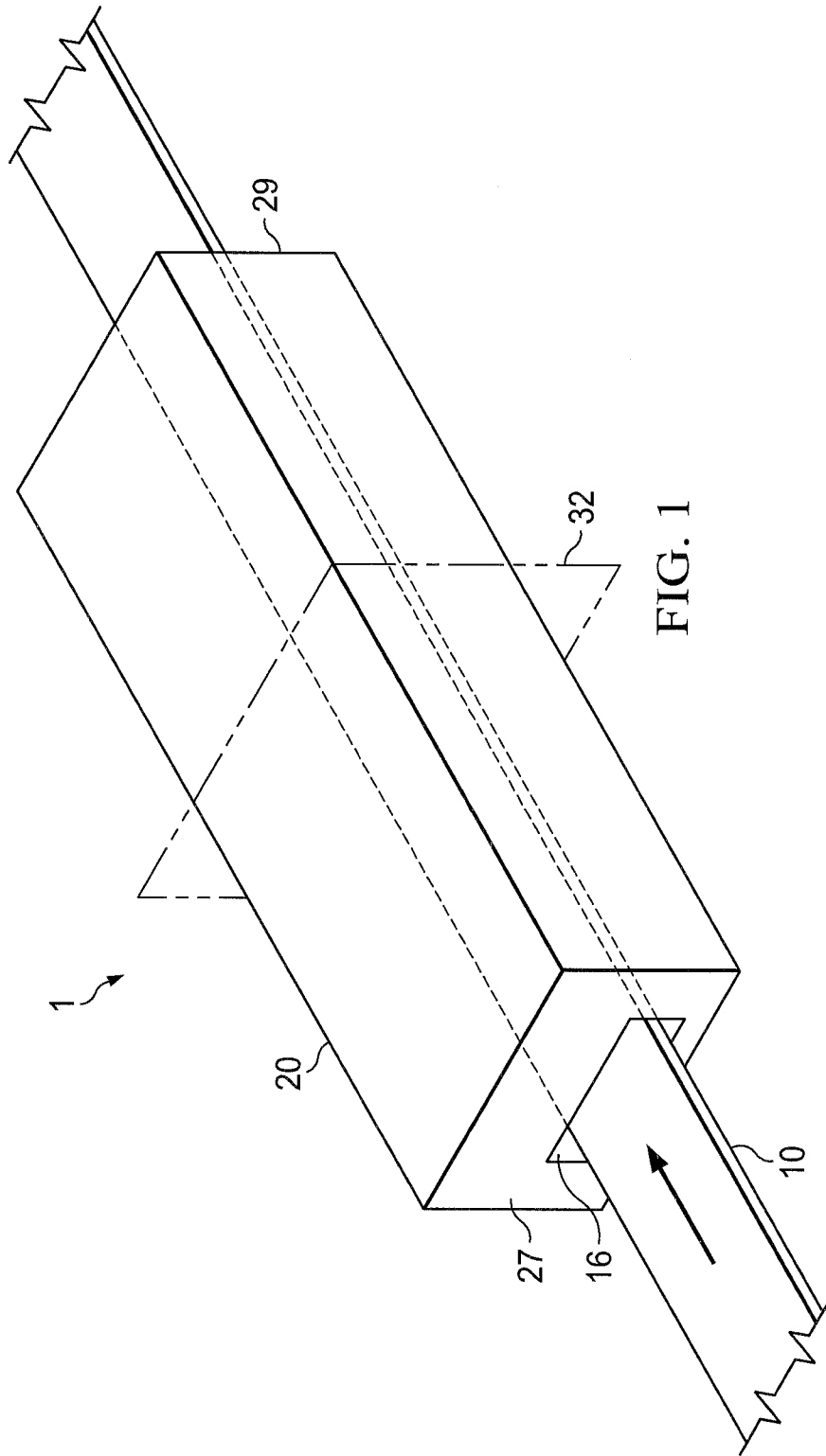

FIG. 1

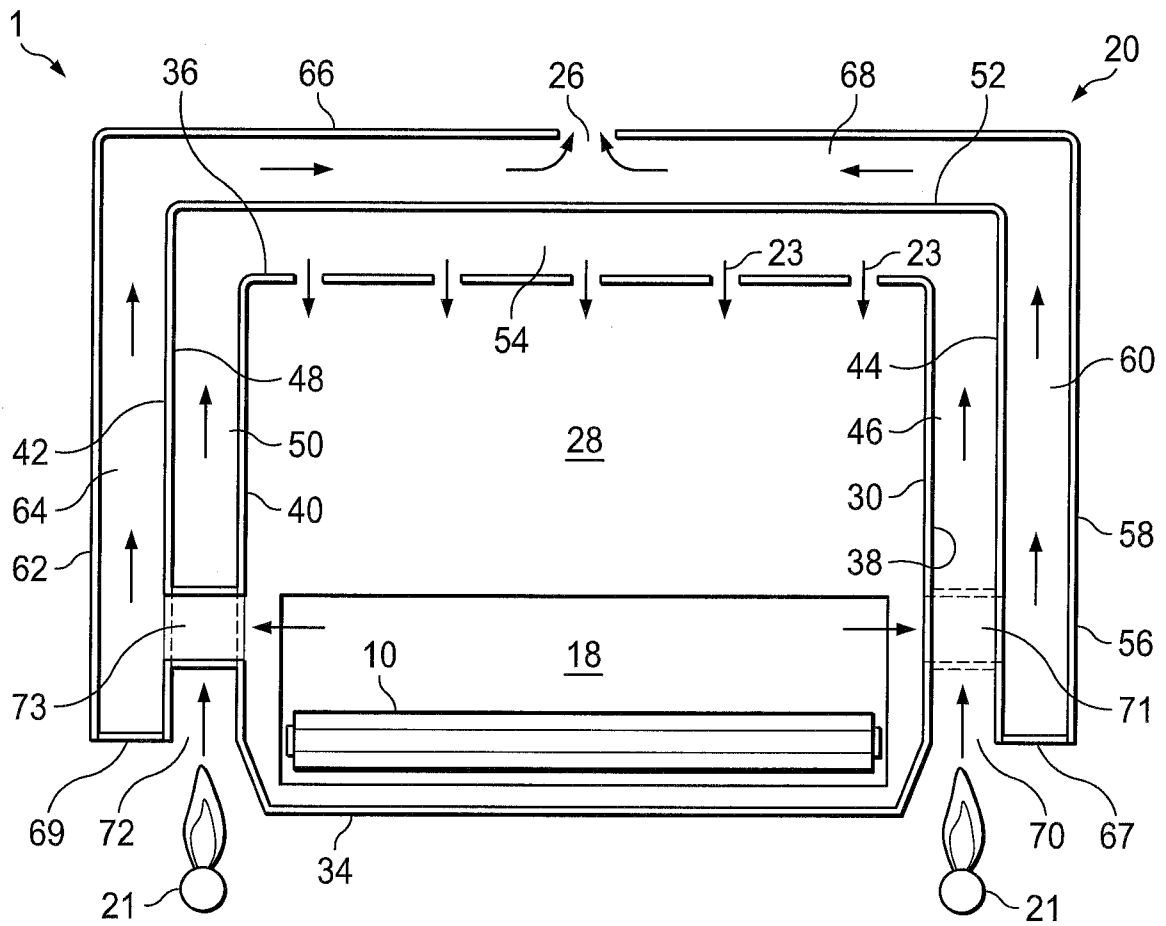
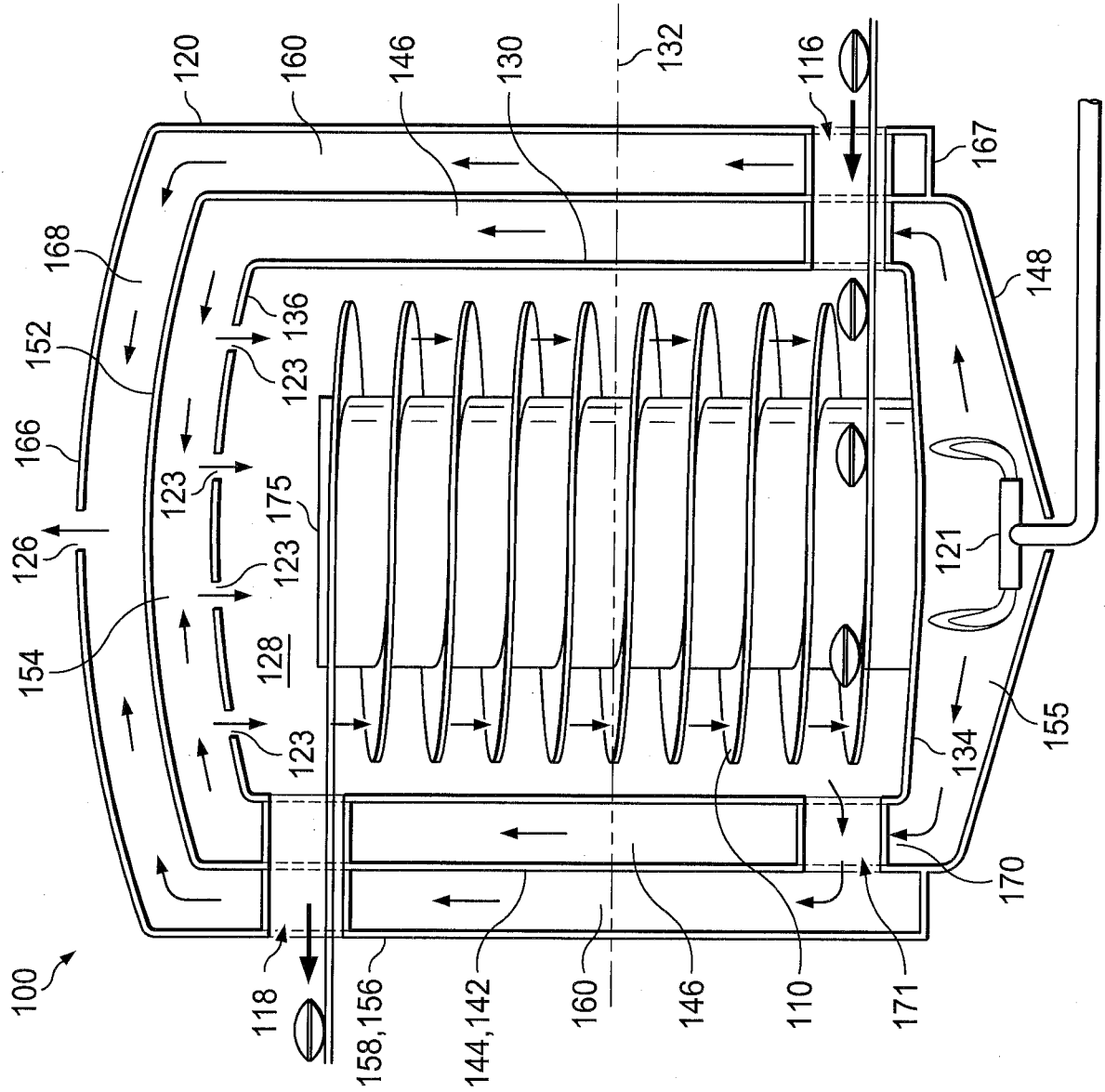

FIG. 2

FIG. 3



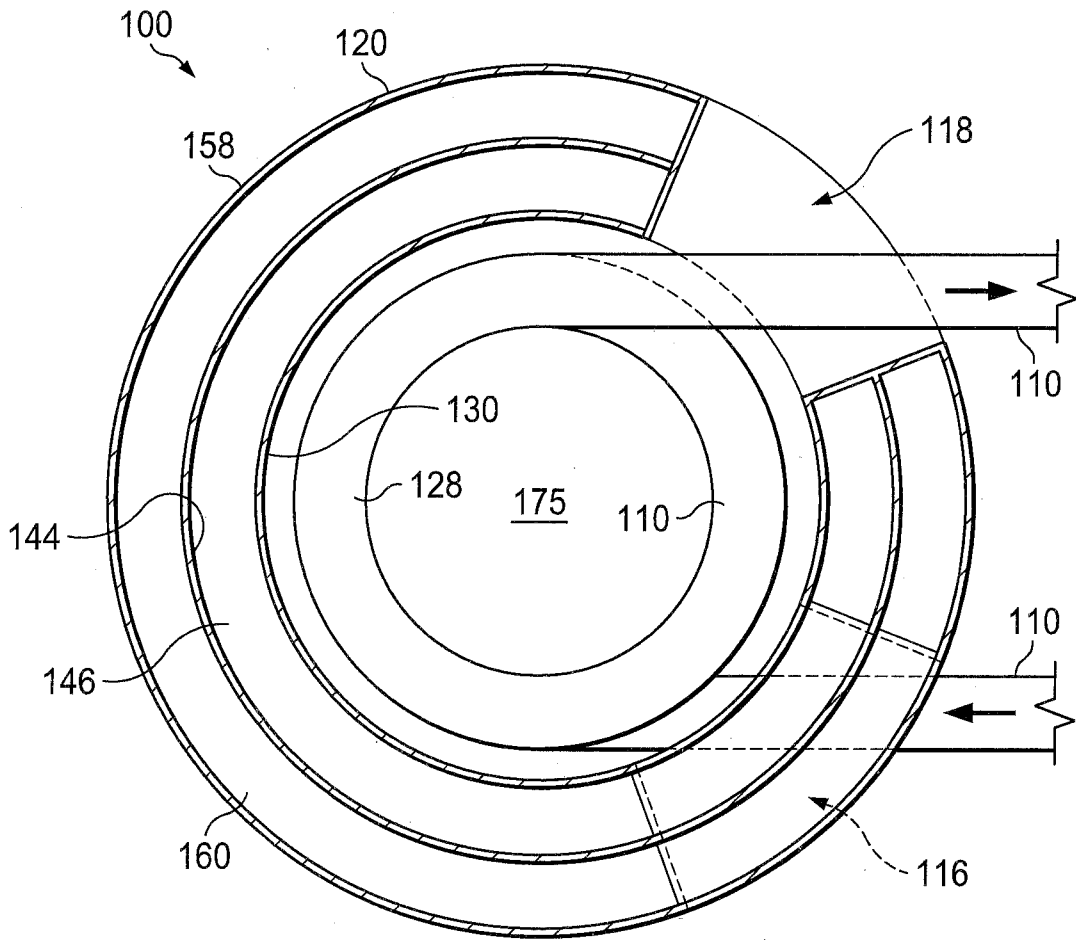

FIG. 4

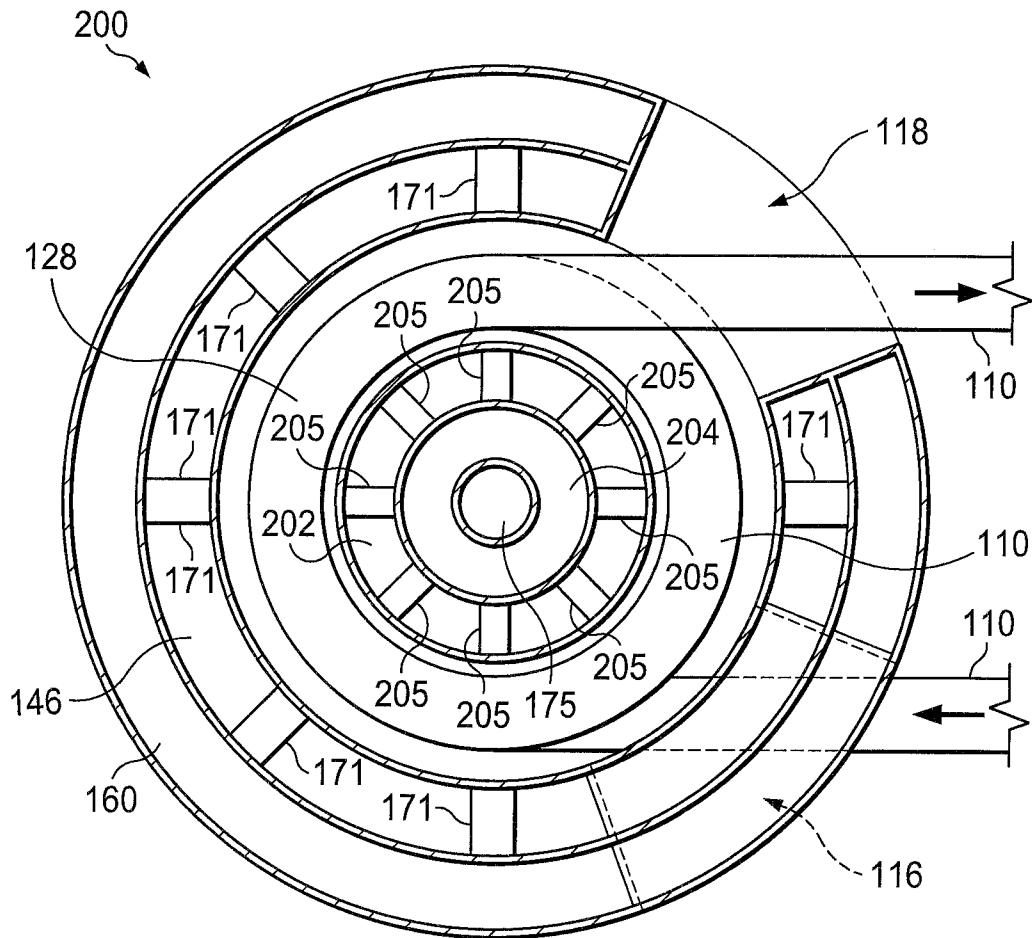

FIG. 5

INTERNATIONAL SEARCH REPORT

International application No.

PCT/US2014/042516

A. CLASSIFICATION OF SUBJECT MATTER

IPC(8) - A21B 1/48 (2014.01)

CPC - A21B 1/48 (2014.09)

According to International Patent Classification (IPC) or to both national classification and IPC

B. FIELDS SEARCHED

Minimum documentation searched (classification system followed by classification symbols)

IPC(8) - A21B 1/24, 1/28, 1/40, 1/42, 1/48; A23L 3/36; B65G 15/02, 21/02; A47J 27/16, 37/04 (2014.01)

CPC - A21B 1/24, 1/26, 1/40, 1/42, 1/48; A23L 3/361, 3/362; B65G 21/18, 2207/24; C10J 3/487 (2014.09)

Documentation searched other than minimum documentation to the extent that such documents are included in the fields searched
USPC - 99/443C; 110/101R, 104R; 126/21A; 198/642, 778, 850; 219/388

Electronic data base consulted during the international search (name of data base and, where practicable, search terms used)

PatBase, Google Patent, Google

C. DOCUMENTS CONSIDERED TO BE RELEVANT

Category*	Citation of document, with indication, where appropriate, of the relevant passages	Relevant to claim No.
A	US 2012/0318254 A1 (HOWARD) 20 December 2012 (20.12.2012) entire document	1-37
A	US 5,320,086 A (BEAL et al) 14 June 1994 (14.06.1994) entire document	1-37
A	US 5,322,007 A (CARIDIS et al) 21 June 1994 (21.06.1994) entire document	1-37
A	US 2006/0042473 A1 (SILVESTRINI) 02 March 2006 (02.03.2006) entire document	1-37

 Further documents are listed in the continuation of Box C.

* Special categories of cited documents:

"A" document defining the general state of the art which is not considered to be of particular relevance

"E" earlier application or patent but published on or after the international filing date

"L" document which may throw doubts on priority claim(s) or which is cited to establish the publication date of another citation or other special reason (as specified)

"O" document referring to an oral disclosure, use, exhibition or other means

"P" document published prior to the international filing date but later than the priority date claimed

"T" later document published after the international filing date or priority date and not in conflict with the application but cited to understand the principle or theory underlying the invention

"X" document of particular relevance; the claimed invention cannot be considered novel or cannot be considered to involve an inventive step when the document is taken alone

"Y" document of particular relevance; the claimed invention cannot be considered to involve an inventive step when the document is combined with one or more other such documents, such combination being obvious to a person skilled in the art

"&" document member of the same patent family

Date of the actual completion of the international search

25 September 2014

Date of mailing of the international search report

04 NOV 2014

Name and mailing address of the ISA/US

Mail Stop PCT, Attn: ISA/US, Commissioner for Patents

P.O. Box 1450, Alexandria, Virginia 22313-1450

Facsimile No. 571-273-3201

Authorized officer:

Blaine R. Copenheaver

PCT Helpdesk: 571-272-4300

PCT OSP: 571-272-7774