

Nov. 26, 1935.

A. B. HANSEN

2,022,345

CARD TABLE

Filed Nov. 1, 1934

2 Sheets-Sheet 1

Fig. 1.

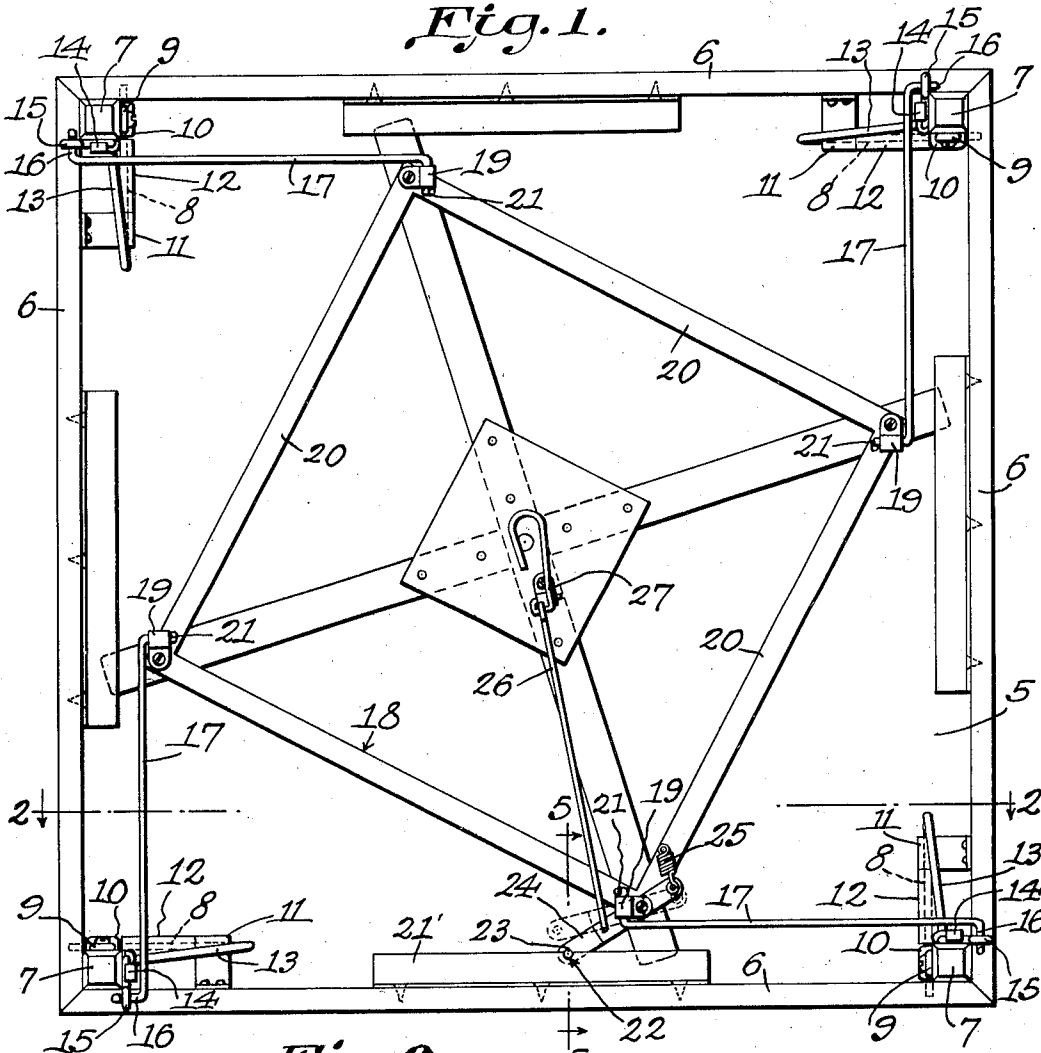

Fig. 2.

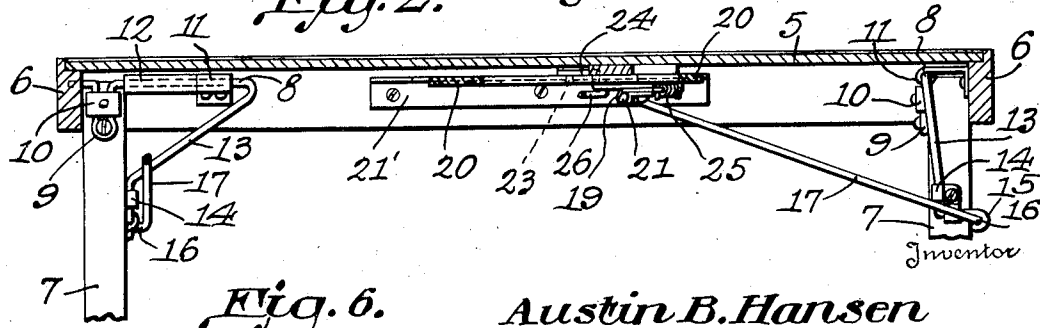
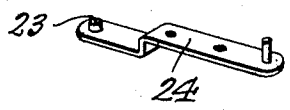

Fig. 6.



Austin B. Hansen

By *Chas. H. Snow & Co.*
Attorneys

Nov. 26, 1935.

A. B. HANSEN

2,022,345

CARD TABLE

Filed Nov. 1, 1934

2 Sheets-Sheet 2

Fig. 3.

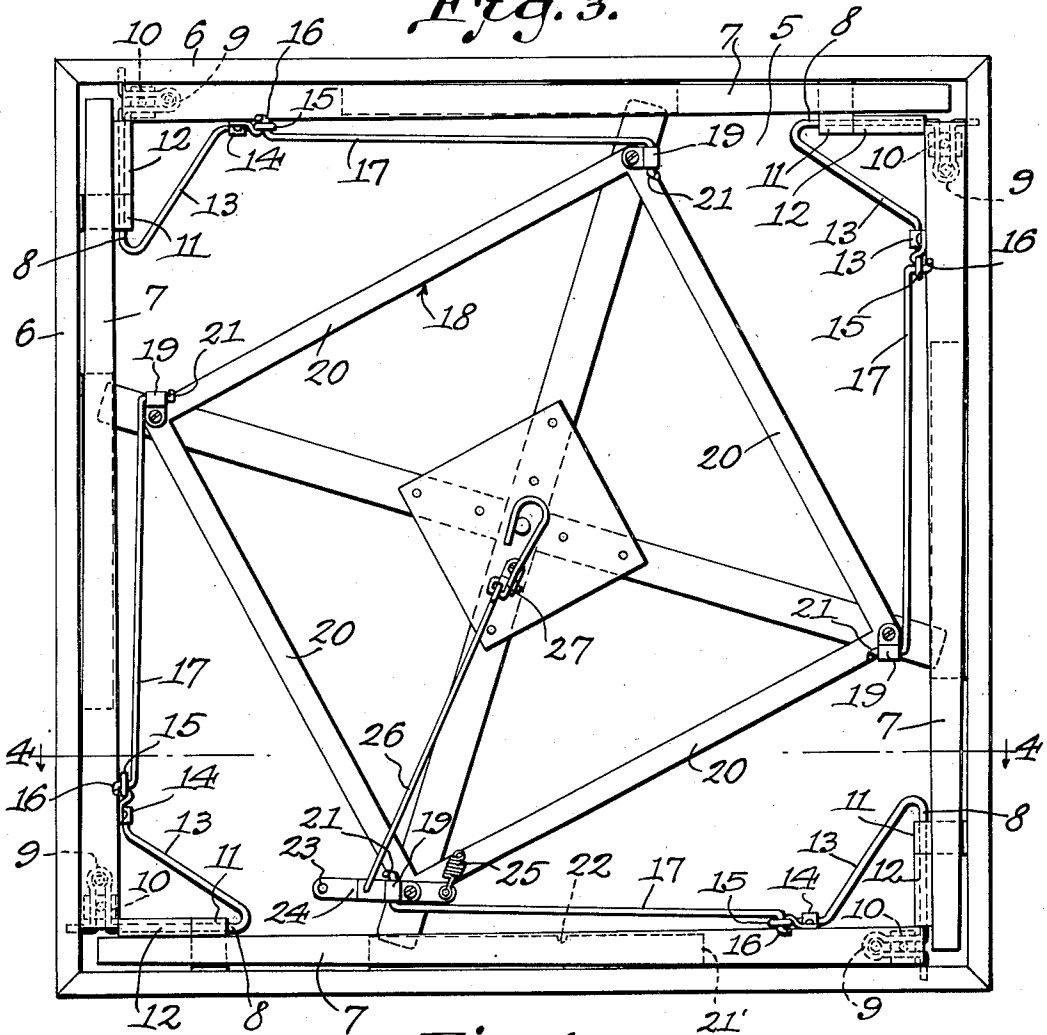

Fig. 4.

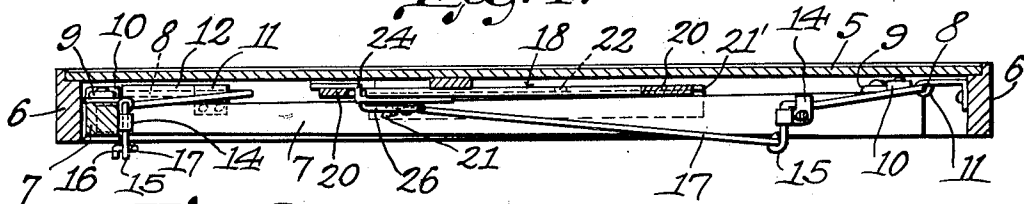
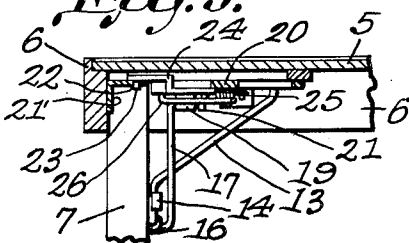

Fig. 5.



Inventor

Austin B. Hansen

By *Cashow & Co.*

Attorneys

UNITED STATES PATENT OFFICE

2,022,345

CARD TABLE

Austin B. Hansen, Carlton, Oreg., assignor of
one-half to Robert W. Jarrett, Carlton, Oreg.

Application November 1, 1934, Serial No. 751,045

3 Claims. (Cl. 311—98)

This invention relates to card or game tables, the primary object of the invention being to provide a table wherein all of the legs will be moved to their active or inactive positions simultaneously, by a movement of one of the legs.

An important object of the invention is to provide a table of this character including hinges for connecting the legs to the table, the hinges being constructed in such a way that the inner ends of the table legs will be spaced from the edges of the table top, permitting one leg to swing to position between the inner end of the adjacent table leg and the edging of the table top, where the table legs will be out of the way to facilitate storing of the table.

A further object of the invention is to provide a hinge which will brace the legs of the table against lateral movement, insuring an exceptionally rigid structure.

A still further object of the invention is to provide securing means whereby the legs will be held in their active positions when extended and the table has been made ready for use.

With the foregoing objects in view, the invention resides in the combination and arrangement of parts and in the details of construction herein-after described and claimed, it being understood that changes in the precise embodiment of the invention herein disclosed, may be made within the scope of what is claimed, without departing from the spirit of the invention.

Referring to the drawings:

Figure 1 is a bottom view of a table constructed in accordance with the invention, the legs of the table being shown in their open or active positions.

Figure 2 is a sectional view taken on line 2—2 of Figure 1.

Figure 3 is a bottom view of the table, the legs of the table being shown in their closed or inactive positions.

Figure 4 is a sectional view taken on line 4—4 of Figure 3.

Figure 5 is a sectional view taken on line 5—5 of Figure 1.

Figure 6 is a perspective view of the latch bar forming a part of the leg locking means.

Referring to the drawings in detail, the table top is indicated generally by the reference character 5, and is provided with edging strips 6 that extend below the table top, and provide means to which the table legs are pivotally connected.

The table legs are indicated by the reference character 7, each table leg being pivotally secured to the under-side of the table top, by means of

a hinge embodying a rod formed with a substantially straight portion 8 having a loop 9 through which a screw is positioned, to secure the hinge to the legs, there being also provided a clip 10 adjacent to the loop, which further braces the leg.

As shown, one end of each rod extends into an opening of the edging strip associated therewith providing a pivotal connection between the hinge and table leg.

Tubular bearing members indicated by the reference character 11, are secured to the inner surface of the edging strips, and accommodate the straight portions of the rods, of which the hinges are formed, bracing the hinges at these points. Tubular spacing members 12 are mounted on the rods between the bearing members 11 and the legs, holding the legs against inward movement, through the tubular bearing members.

Each of the rod or hinge members embodies an inclined portion 13 that extends to a point where it connects with the table leg associated therewith. A clip 14 embraces a portion of the hinge member, securing the hinge member to its leg member.

The outer ends of the rods or hinge members are bent laterally and are formed into eyes 15 through which the right angled-ends 16 of the connecting rods 17 extend, the inner ends of the connecting rods having pivotal connection with the rotary member 18, through the medium of the bearing members 19, that are pivotally mounted on the rotary member 18, near the outer ends of the bars 20, of which the rotary member is constructed.

The extreme ends of the connecting rods 17 are bent laterally as at 21, preventing the connecting rods from moving from the bars 20.

Secured to the under-side of the table is a plate 21' that is provided with a notch 22, which notch accommodates the pin 23 carried by the latch bar 24, which latch bar is pivotally connected to the rotary member and urged outwardly by means of the coiled spring 25, to the end that the pin 23 will be directed to the notch when the latch bar is moved along the plate 21.

A rod 26 is connected to the latch bar 24, and has pivotal connection with the lever 27, which has pivotal connection with the rotary member 18, the lever 27 being so constructed that when it is moved past dead center in either direction, the rod 26 will be held against movement.

From the foregoing it will be seen that when it is desired to move the leg members to their open positions, one of the leg members may be

swung outwardly. It follows that the rotary member will move, with this movement of the leg member, swinging all of the leg members to their open positions.

5 The pin of the latch bar will now be forced into the notch of the plate 21, securing the leg members in their open or active positions.

10 It will further be seen that due to the construction of the hinges, the leg members are held against one of the edging strips, and prevented from movement by this engagement with the edging strips, and that the leg members will be prevented from movement in the opposite direction, by reason of the fact that the hinges extend 15 appreciable distances inwardly, beyond the ends of the leg members.

Should it be desired to move the leg members to their inactive positions, it is only necessary to operate the latch member, whereupon movement 20 of any one of the leg members will cause all of the leg members to swing inwardly into positions against the bottom of the table top.

Having thus described the invention, what is claimed is:

25 1. In a table, a table top, leg members providing a support for the table top, means for pivotally connecting the leg members to the table top, said connecting means comprising an elongated plate, a tubular bearing formed on 30 one edge of the plate, a hinge member including a rod positioned in the tubular member, said rod being formed with a loop, a screw extending through the loop securing the rod to the table

leg associated therewith, said rod having an inclined portion, the free end of the inclined portion being secured to the leg, and means for securing the plate to the table top.

2. In a table, a table top, leg members supporting the top, means for pivotally connecting 5 the leg members to the table top, said connecting means comprising an elongated plate, means extending from one edge of the plate for securing the plate to the table top, a tubular bearing 10 formed along the opposite edge of the plate, a hinge member comprising a rod fitted in the bearing member, a loop at one end of the rod providing an eye through which a securing screw is positioned securing the rod to a table leg, and 15 means for securing the opposite end of the rod to the leg member at a point in spaced relation with the plate.

3. In a table, a table top, leg members, means for pivotally connecting the leg members to the 20 table top, said connecting means including a plate, a right angled flange extending from one edge of the plate and having an opening through which a securing screw is passed securing the plate to the table top, a tubular bearing formed 25 along the opposite edge of the plate, a hinge member including a rod positioned in the bearing member, one end of the rod being secured to one side of the table leg, and means for securing the rod to one side of the leg at a point spaced 30 an appreciable distance from the plate.

AUSTIN B. HANSEN.