

E. DUNNING.
FIRE ESCAPE.

No. 523,978.

Patented Aug. 7, 1894.

Fig. 4

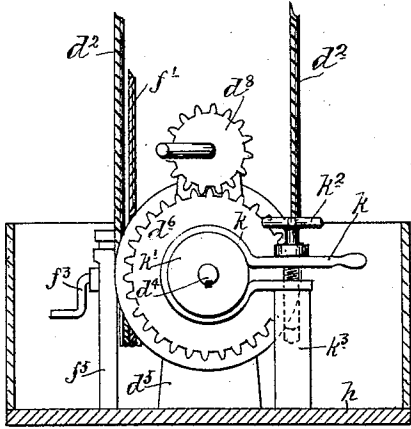
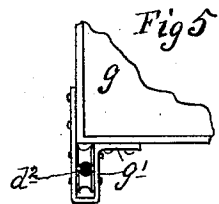
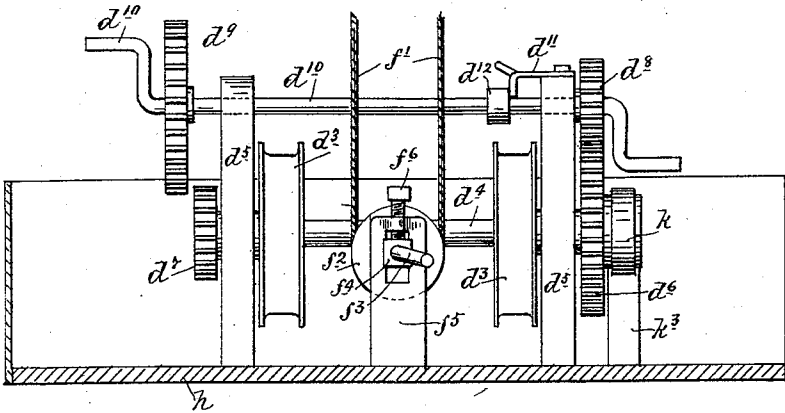

Fig. 3.



Witnesses.
 E. Felice Elmore.
 P. Davidson Merdunk

Inventor.
 Elisha Dunning
 by his Attorney,
 Jas. F. Williamson

UNITED STATES PATENT OFFICE.

ELISHA DUNNING, OF MINNEAPOLIS, MINNESOTA, ASSIGNOR OF ONE-FOURTH TO ANGUS McDONALD, OF SAME PLACE.

FIRE-ESCAPE.

SPECIFICATION forming part of Letters Patent No. 523,978, dated August 7, 1894.

Application filed March 10, 1894. Serial No. 503,091. (No model.)

To all whom it may concern:

Be it known that I, ELISHA DUNNING, a citizen of the United States, residing at Minneapolis, in the county of Hennepin and State of Minnesota, have invented certain new and useful Improvements in Fire-Escapes; and I do hereby declare the following to be a full, clear, and exact description of the invention, such as will enable others skilled in the art to which it appertains to make and use the same.

My invention has for its object to provide a convenient and reliable form of fire-escape.

To this end, the invention consists of certain novel devices and combinations of devices, which will be hereinafter described and defined in the claims.

The invention is illustrated in the accompanying drawings, in which, like letters referring to like parts—

Figure 1 is a front and Fig. 2 a side elevation of my fire-escape, shown as applied to a building with some parts broken away. Fig. 3 is a view, partly in front elevation and partly in section, showing the platform and parts thereon, detached, with some parts broken away and others removed. Fig. 4 is a view, partly in side elevation and partly in section, of the same parts shown in Fig. 3. Fig. 5 is a detail in plan, showing a part of the relief car in its relation to its supporting and operating cables.

a represents one of the vertical walls, a' the several floors, a^2 the coping, and a^3 the windows of a building.

b represent brackets or other forms of rigid projecting parts attached to the upper story of the building, directly under the coping a^2 , or at any other desired level, on the exterior of the building. To the said brackets b , is rigidly secured a guide-rail b' , extending along the several walls of the building or of a particular wall thereof, and constitutes an overhead support and runway for the fire-escape. On the said guide-rail b' , is mounted a suitable truck, shown as composed of a yoke c provided with upper and lower flanged wheels c' , embracing the upper and lower

edges of the guide-rail b' , and as provided with a sheave yoke or bracket c^2 . In the sheave-yoke c^2 is journaled a sheave shaft d , provided with a pair of cable-sheaves d' ; and on the projecting journal of the upper member of the truck-wheels c' is fixed another cable-sheave f . On the sheaves d' are mounted a pair of endless cables d^2 , which extend to and co-operate with a pair of sheaves d^3 on a sheave or drum shaft d^4 , journaled in bearing blocks d^5 , made rigid with a platform h , shown as of box-like form and provided with wire netting sides h' . On the sheave f , is mounted a third endless cable f' , which extends to a sheave f^2 on windlass shaft f^3 journaled in sliding bearings f^4 , mounted in bearing-blocks f^5 , fixed to the platform h , which bearings f^4 are securable in any desired adjustment in their seats by draw-bolts f^6 . The three endless cables, just noted, support the said platform h from the said truck on the guide b' at any desired level above the ground, as for example, at or near the top of the first story; and the said platform is provided with horizontal wheels h^2 journaled thereto, which are adapted to bear against and travel along the wall of the building, for taking the inward strain on the platform and spacing the same apart from the wall of the building.

The sheave or drum-shaft d^4 is provided at its opposite ends with spur-gears d^6 and d^7 , respectively, of different sizes, which are interchangeably engageable with a corresponding pair of spur-gears d^8 d^9 , on a crank or windlass shaft d^{10} , which is also journaled in the bearing-blocks d^5 . The gear d^6 on the drum-shaft d^4 is relatively large, as compared with the gear d^8 on the crank-shaft d^{10} , the ratio being about two to one; and the gear d^7 on the drum-shaft d^4 is relatively small, as compared with the gear d^9 on the crank-shaft d^{10} , the ratio being about one to two.

The crank-shaft d^{10} is free for sliding movement in its bearings, but may be held in either one of two positions by a stiff spring-latch d^{11} , engageable with either side of a collar d^{12} fixed on the shaft d^{10} . This construc-

tion permits either the set of gears d^6 and d^8 , or the set of gears d^7 and d^9 , to be thrown into operative relation with respect to each other, according to whether power or speed is desired.

A relief car g is secured to the rear sections of the pair of cables d^2 , so as to be movable therewith, and is provided with roller equipped keepers g' , which engage and work upon the front sections of said cables d^2 , as guides. Otherwise stated, the relief car g is so mounted on the said cables d^2 , that it will be carried with the sections thereof, moving in one direction, and will slide on the sections thereof, moving in the opposite direction. The car is therefore both operated and guided by the cables d^2 and may be moved up and down, at will, by manipulating the windlass or crank shaft d^{10} . The endless cables d^2 are preferably given a single or double wrap around the windlass sheaves or drums d^3 , to prevent any slipping of the same when manipulating the car g .

The cable f' , in combination with the sheave f on the truck, and the sheave f^2 on the platform, not only co-operates with the cables d^2 , to support the platform h , but serves to propel the entire fire-escape lengthwise of the overhead guide-rail b' . The weight of the fire-escape is taken by the upper truck-wheel c' , on the guide-rail b' , thereby affording a considerable traction; which is quite sufficient to propel the truck and fire-escape, as an entirety from the windlass f^3 on the platform. The entire fire-escape may therefore be moved lengthwise of the building by an operator on the platform h , to bring the same in line with the proper windows or other openings; and when this point is reached, the relief car g may be raised to the desired level, to receive the person or other load and again be lowered to the platform.

A fire-escape of this kind possesses the great advantage of being always available from any part of a building. The guide-rails b' would, of course, be constructed on a curve, at the corners of the building, for permitting the fire-escape to be shifted from one side of the building to the other.

The adjustment permitted to the windlass f^3 by the sliding bearings f^4 and draw-bolts f^6 enable more or less of the load on the platform h to be thrown onto the cable f' and the truck driving sheave f , for varying the traction on the truck-wheel c' at will. The cable-sheaves d' and f on the truck, and the sheaves d^3 and f^2 on the platform, are so related that the cables d^2 and f , will tend to hold the platform h in a level position.

For controlling the drum-shaft d^4 , under any excessive weight in the relief car g , a brake is provided for the same in the form of a spring-clamp k engaging a friction disk or pulley k' on said shaft and subject to the action of a draw-bolt or clamping-screw k^2 ,

working freely through the handle portion of said clamp into a screw-threaded seat on the clamp-block k^3 , fixed to the platform h . This construction permits the brake, either to be operated by hand for the desired tension, or to be set down tight by the use of the set-screw or draw-bolt k^2 , working through the handle portion of the clamp.

Of course, it will be understood, that the brackets b , supporting the guide-rail d' , and the wheels h^2 on the bottom of the car would be made of varying dimensions for different buildings, to afford any required clearance, with respect to the walls which might be necessary for the proper operation of the fire-escape. Likewise, it will be understood, that many of the details might be changed, without departing from the spirit of my invention.

What I claim, and desire to secure by Letters Patent of the United States, is as follows:

1. In a fire-escape, the combination with a truck and a platform, of an overhead guide rail extending along the building and supporting said truck, cable sheaves on the truck and the platform, endless cables working over said sheaves and suspending said platform from said truck, and a relief car vertically movable with said cables or certain thereof, substantially as described.

2. In a fire-escape, the combination with a truck and a platform, of an overhead guide-rail extending along a building and supporting said truck, cable sheaves on said truck and said platform, endless cables working over said sheaves and suspending said platform from said truck, and a relief car secured to sections of cables moving in one direction and provided with keepers working on sections of the same cables, moving in the opposite direction, as guides, substantially as described.

3. In a fire escape, the combination with a truck and a platform, of an overhead guide-rail supporting said truck, cable sheaves on said truck and said platform, one of which cable sheaves is applied to one of the truck wheels, and cables working over said sheaves, all of which cooperate in the support of the platform from the truck and one of which serves also to propel the truck on said guide-rail, substantially as described.

4. In a fire-escape, the combination with a truck and a platform, of an overhead guide-rail extending along a building and supporting said truck, cable sheaves on said truck and said platform, one of which cable sheaves is applied to one of the truck-wheels, cables working over said sheaves, all of which cooperate to suspend said platform from said truck, and one of which serves also to propel said truck on said guide-rail, windlasses on said platform for operating said cables, and a relief car supported and operated by certain of said cables, substantially as described.

5. In a fire-escape, the combination with the

truck and platform, of the overhead guide-
rail supporting said truck, sheaves on said
truck and said platform, one of which sheaves
is applied to one of the truck wheels, cables
5 working over said sheaves, all of which co-
operate to support the car and one of which
serves to propel the truck, and adjustable
bearings for that member of the sheaves on
the platform over which runs said truck pro-

PELLING cable, for varying the traction on the
truck, at will, substantially as described.

In testimony whereof I affix my signature in
presence of two witnesses.

ELISHA DUNNING.

Witnesses:

JOHN A. BENOLKIN,
JAS. F. WILLIAMSON.