



US 20080058589A1

(19) **United States**

(12) **Patent Application Publication**  
**Suzuki et al.**

(10) **Pub. No.: US 2008/0058589 A1**

(43) **Pub. Date: Mar. 6, 2008**

(54) **ENDOSCOPE AND ENDOSCOPIC SUTURING INSTRUMENT FOR TREATMENT OF GASTROESOPHAGEAL REFLUX DISEASE**

tinuation of application No. 09/909,980, filed on Jul. 23, 2001, now Pat. No. 6,921,361.

(75) Inventors: **Takayuki Suzuki**, Yokohama-shi (JP);  
**Pankaj P. Pasricha**, Houston, TX (US)

(60) Provisional application No. 60/220,204, filed on Jul. 24, 2000.

Correspondence Address:

**FRISHAUF, HOLTZ, GOODMAN & CHICK, PC**  
220 Fifth Avenue  
16TH Floor  
NEW YORK, NY 10001-7708 (US)

**Publication Classification**

(51) **Int. Cl.**  
**A61B 1/018** (2006.01)  
(52) **U.S. Cl.** ..... **600/104**

(73) Assignee: **OLYMPUS CORPORATION**, Tokyo (JP)

(57) **ABSTRACT**

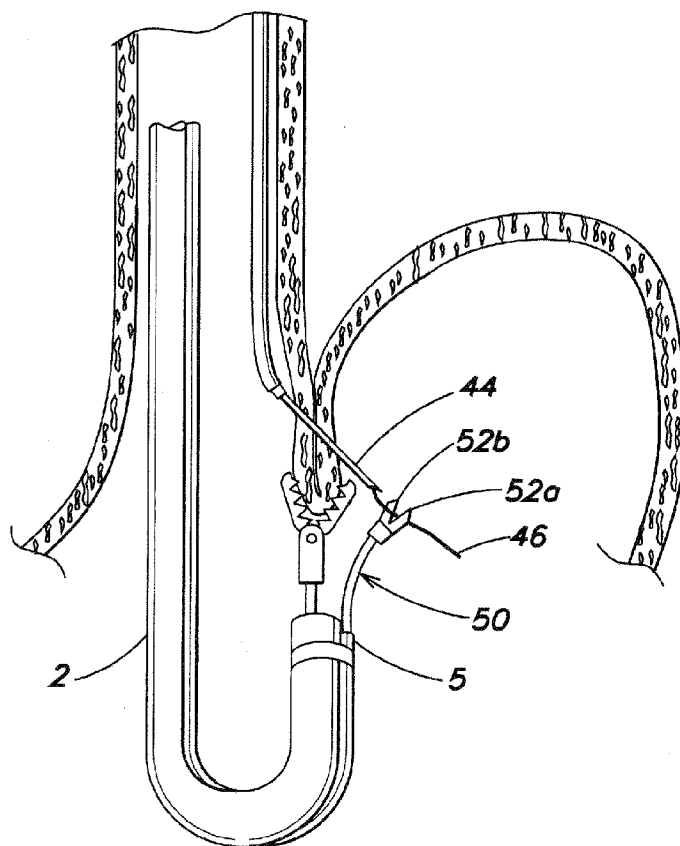
(21) Appl. No.: **11/932,445**

The holding device of the endoscope allows suspension of the tissue while it is held and fixed securely. Use of the holding device with large distal ends will not damage tissue and allows holding and suspension of a large area. A needle pierces at least the proper muscularis, thereby forming a large protrusion including the proper muscularis of the stomach and the esophagus as artificial valve to prevent reflux effectively. The holding device, formed extending out of the distal end of the endoscope, can touch the tissue easily under observation of the endoscope. Treatment is simple, and takes a shorter time.

(22) Filed: **Oct. 31, 2007**

**Related U.S. Application Data**

(60) Division of application No. 10/998,242, filed on Nov. 24, 2004, now Pat. No. 7,318,802, which is a con-



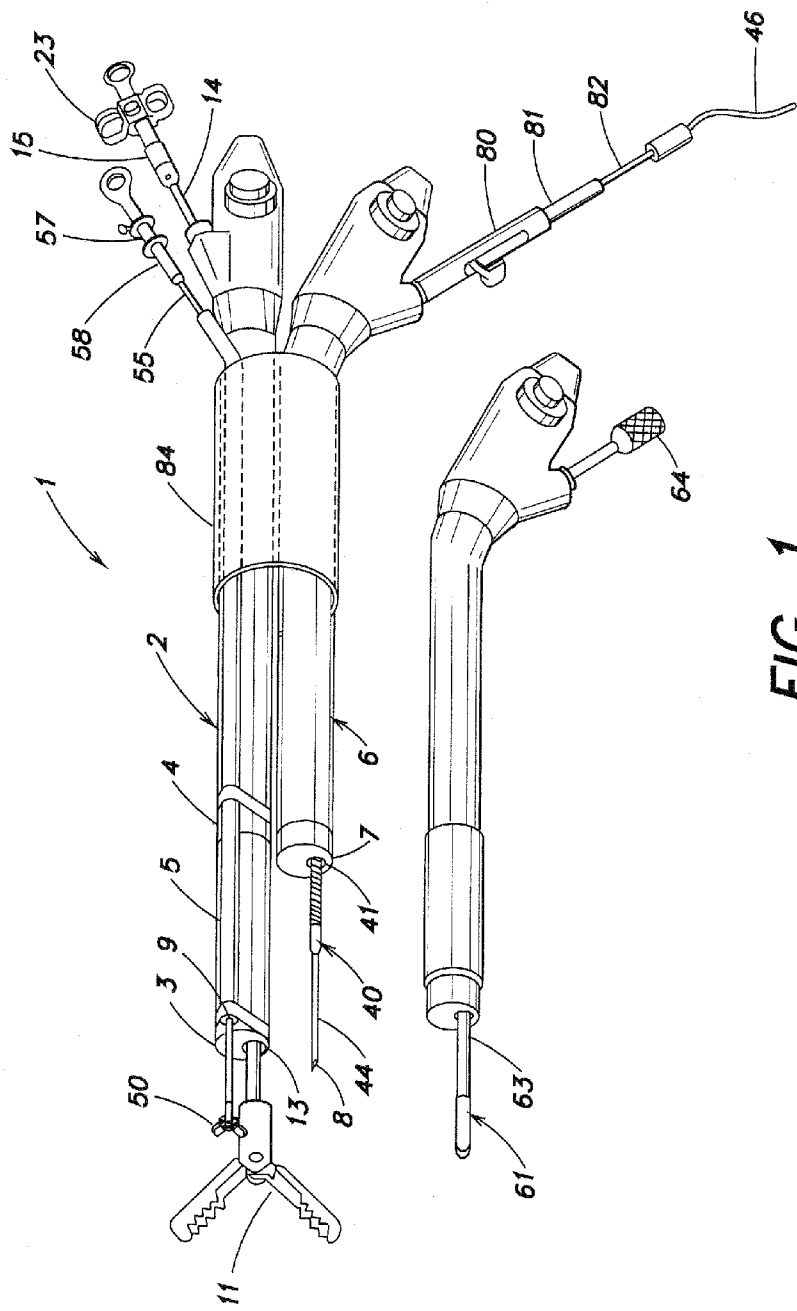


FIG. 1

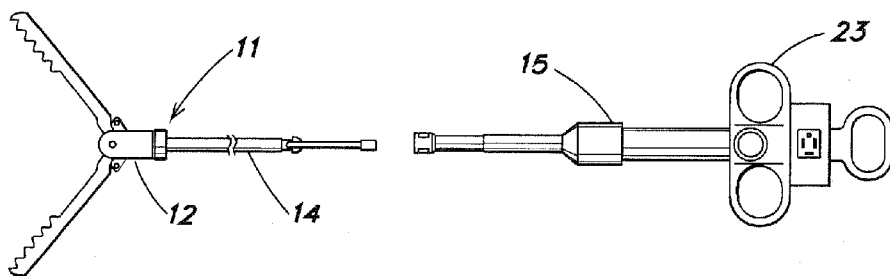


FIG. 2

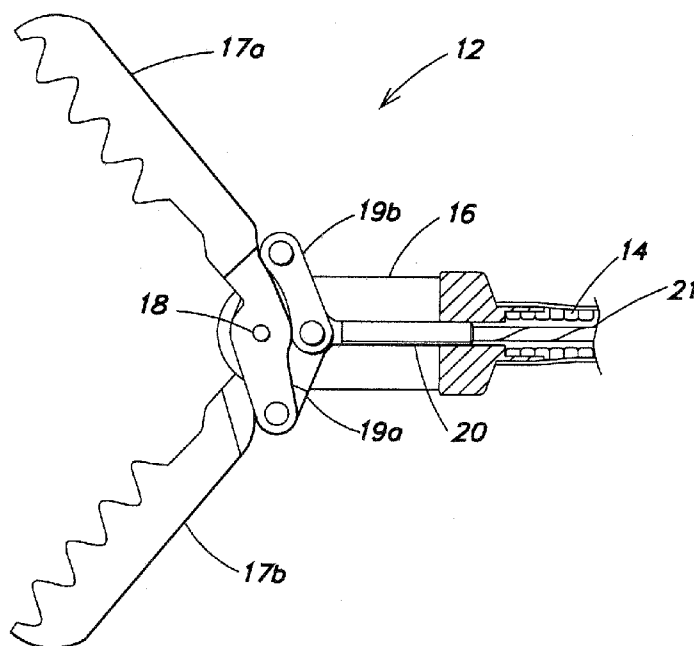


FIG. 3

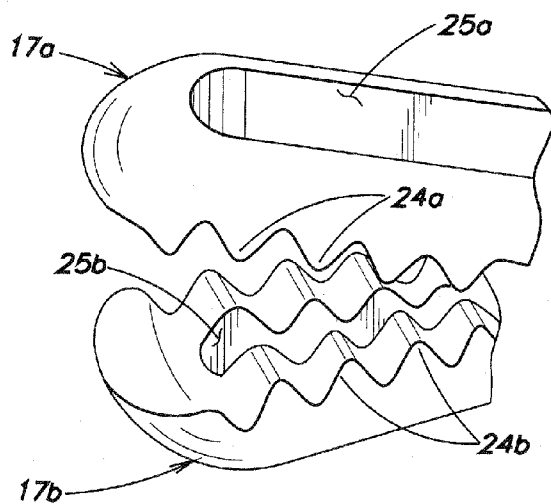


FIG. 4

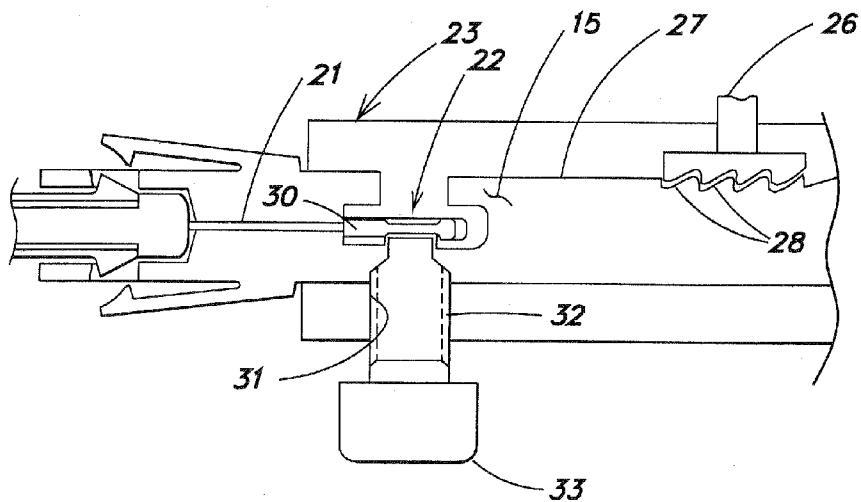


FIG. 6

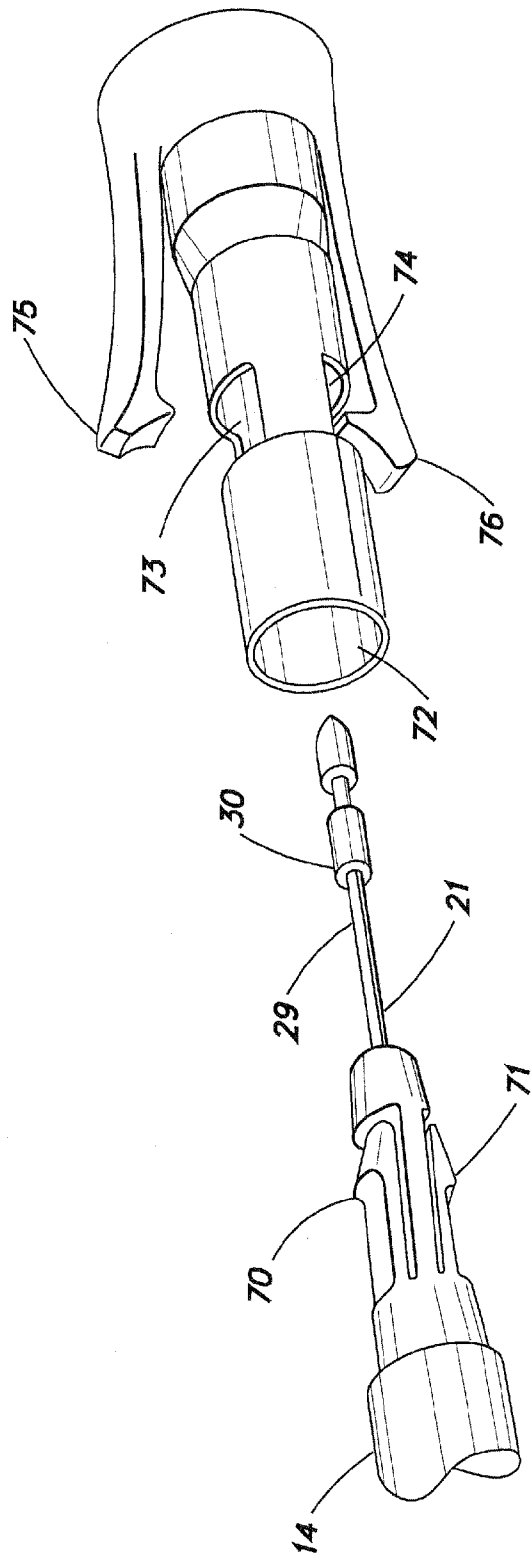


FIG. 5

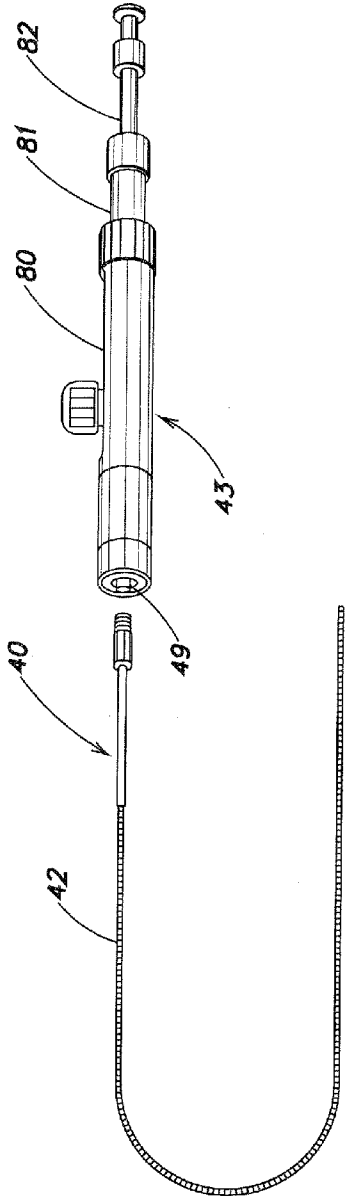


FIG. 7

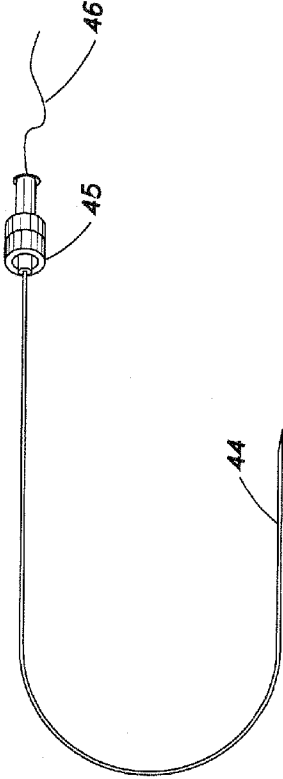


FIG. 8

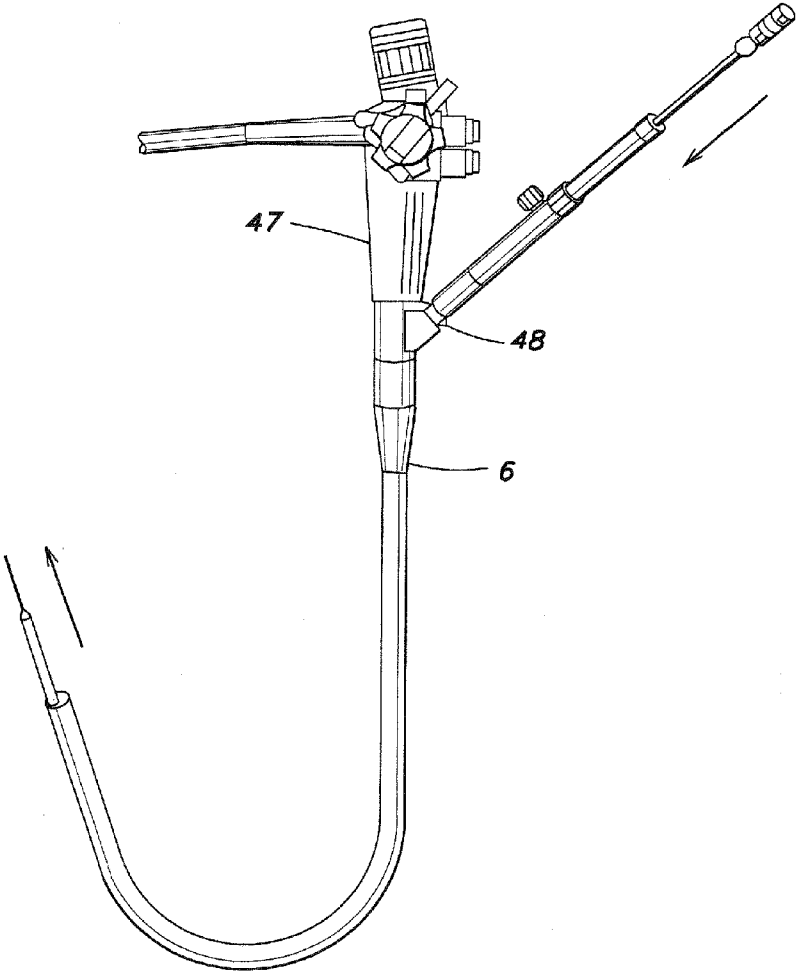
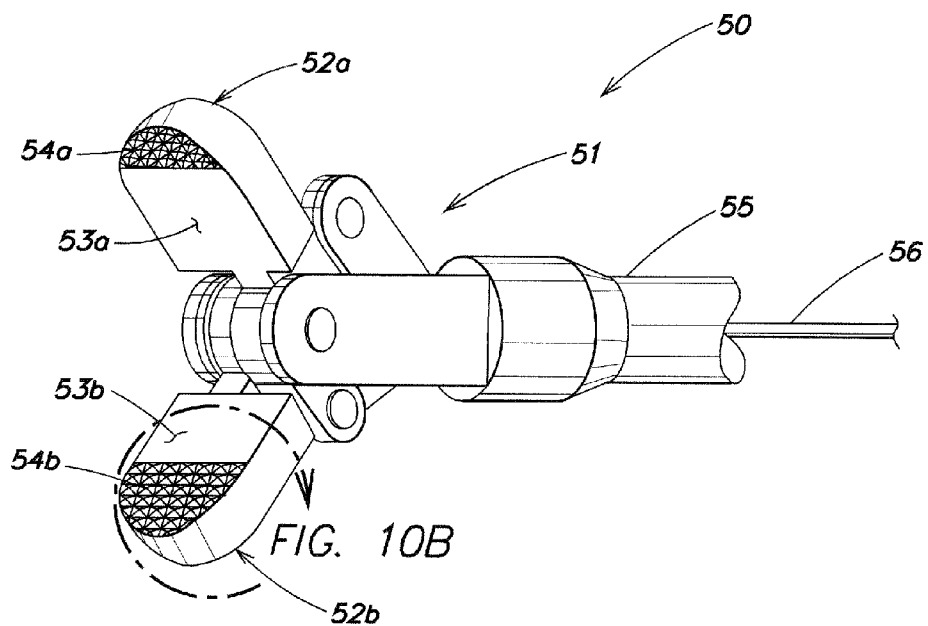
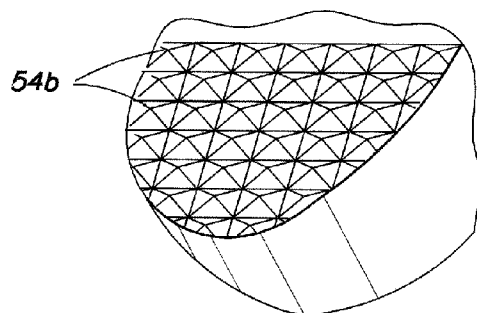


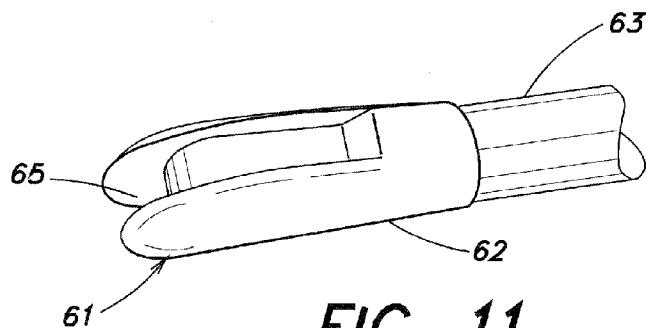
FIG. 9



**FIG. 10A**

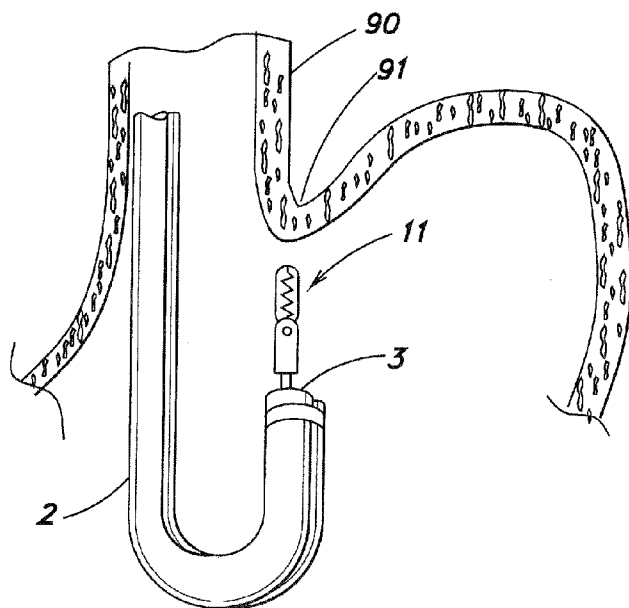


**FIG. 10B**

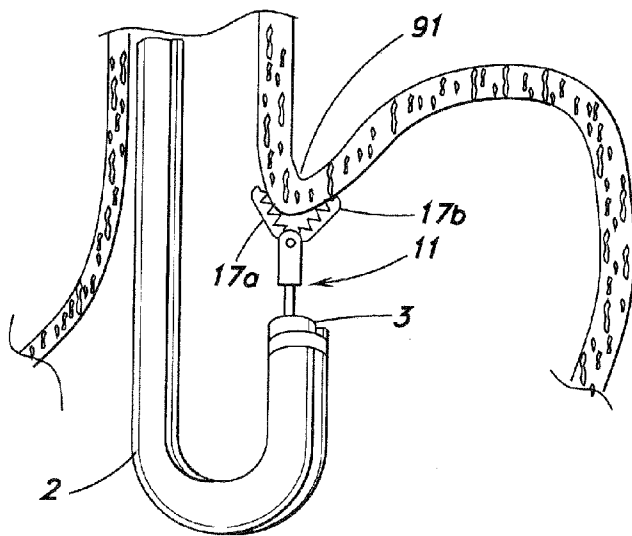


**FIG. 11**

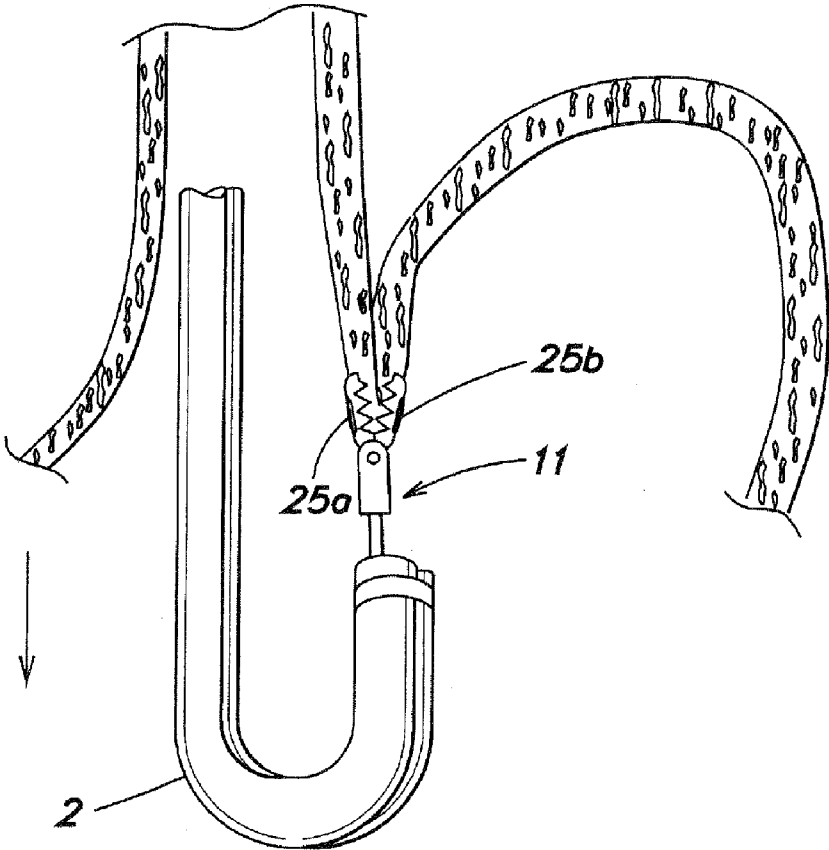




**FIG. 12**



**FIG. 13**



**FIG. 14**

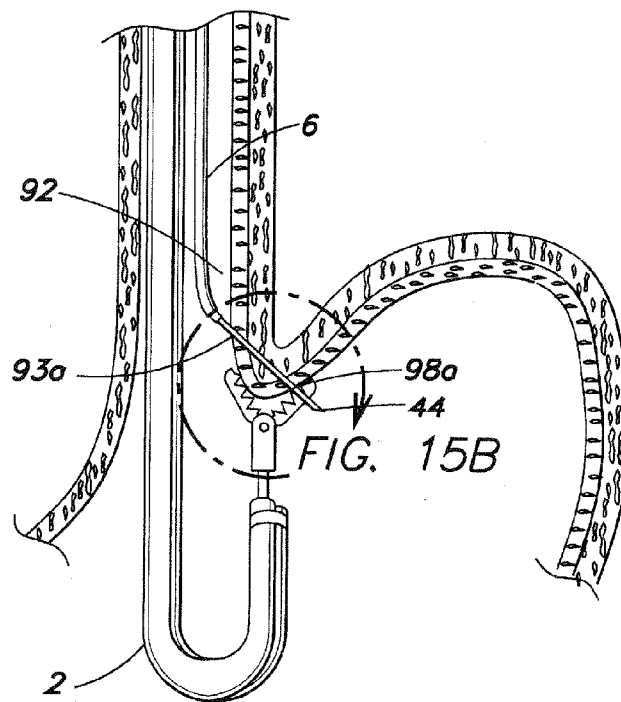


FIG. 15A

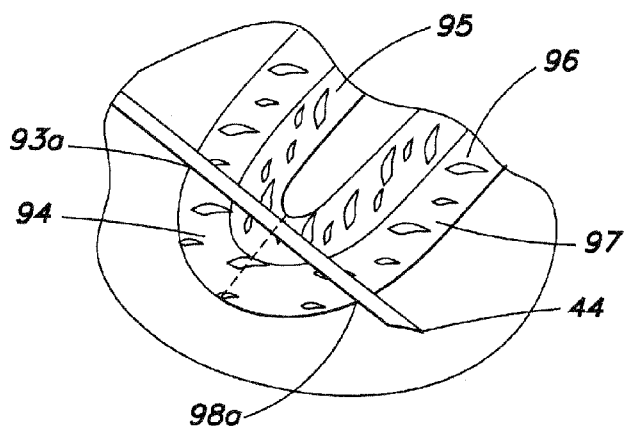
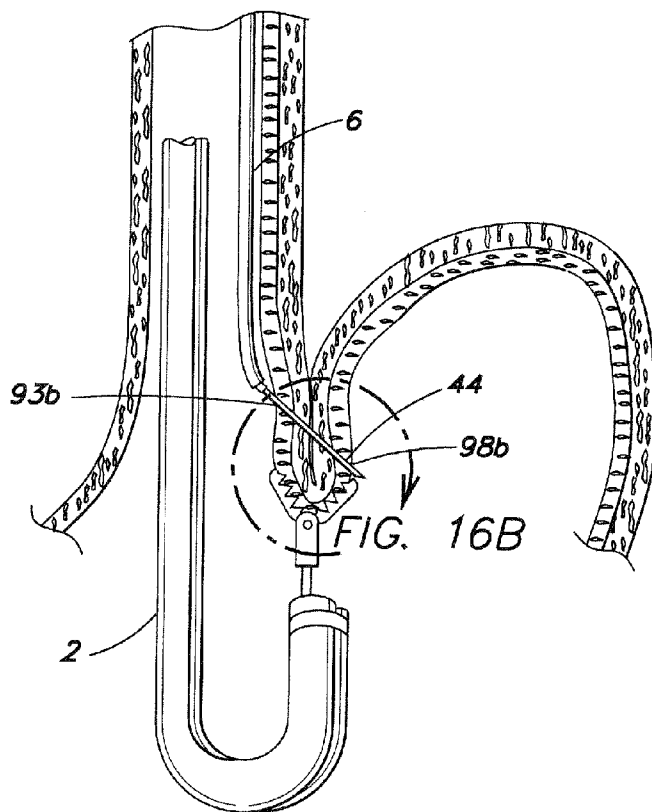
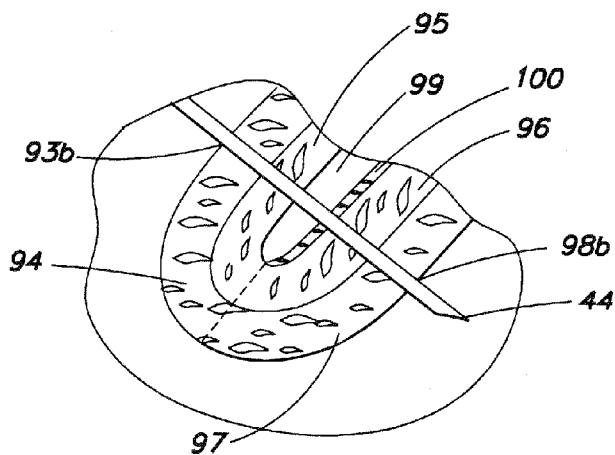


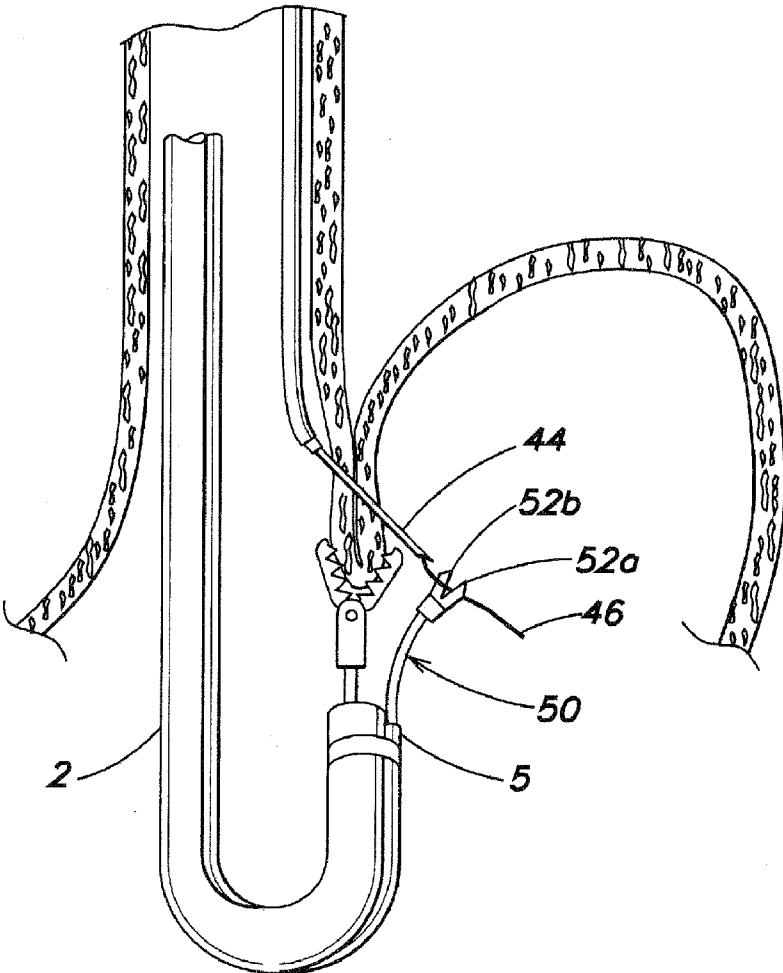
FIG. 15B



**FIG. 16A**



**FIG. 16B**



**FIG. 17**

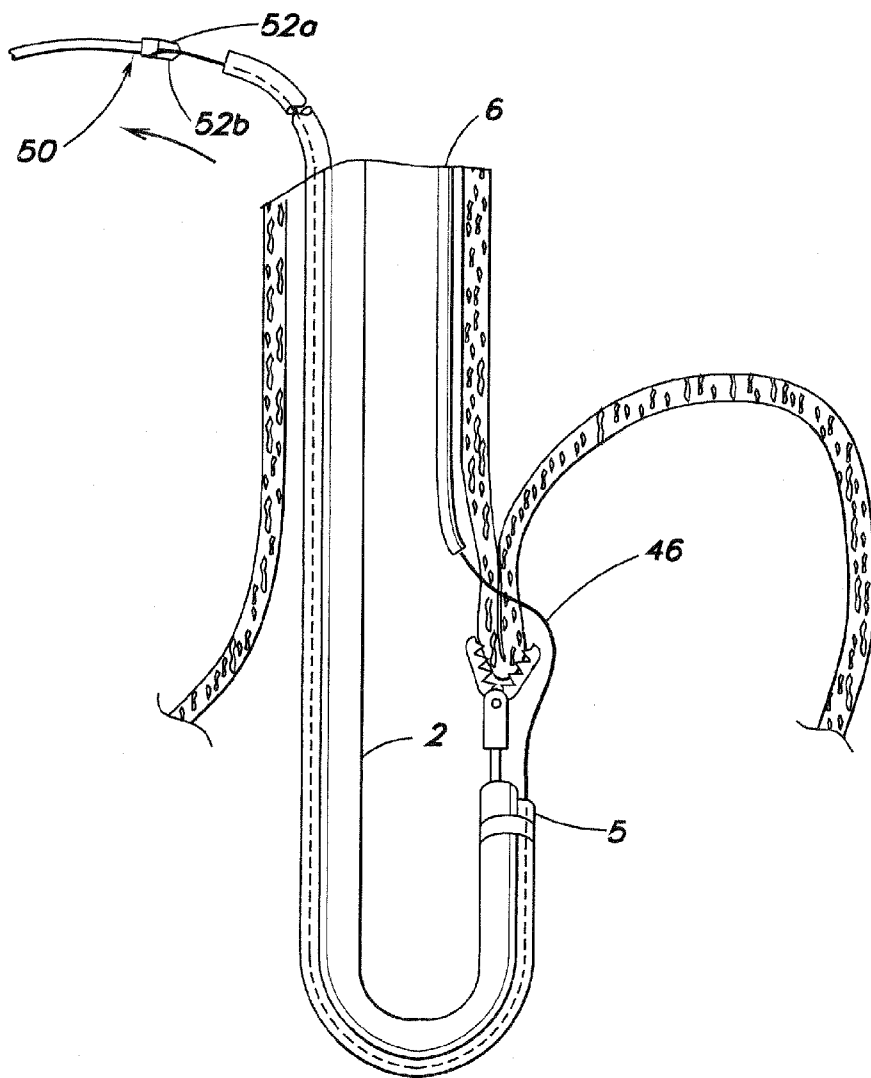


FIG. 18

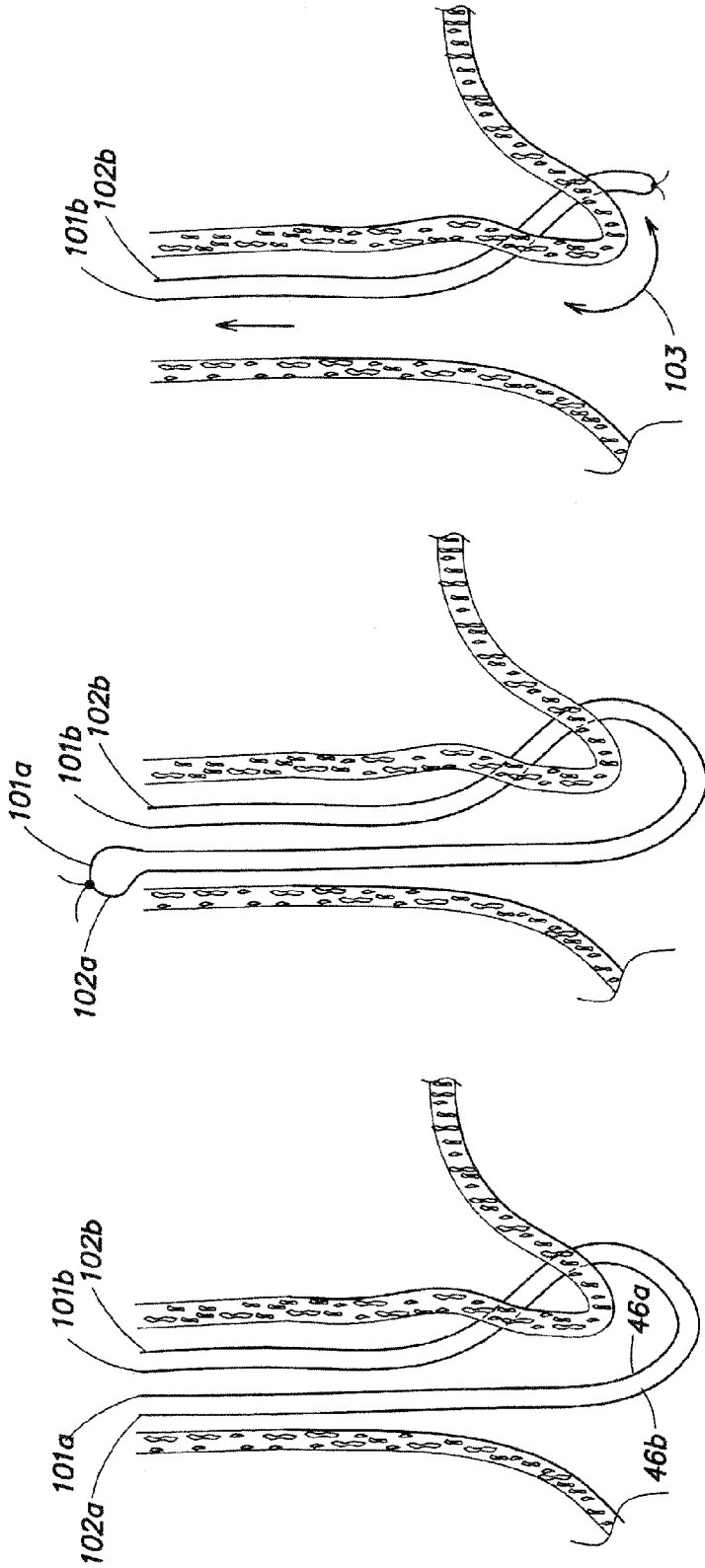


FIG. 21

FIG. 20

FIG. 19

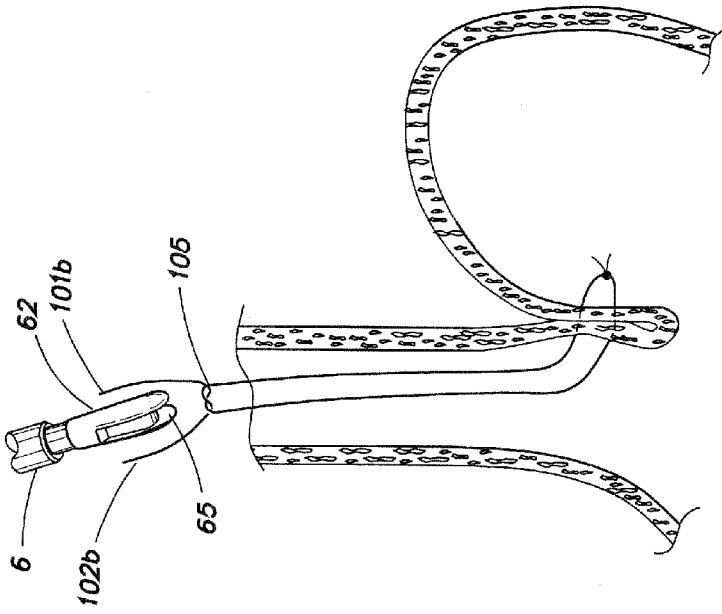


FIG. 23

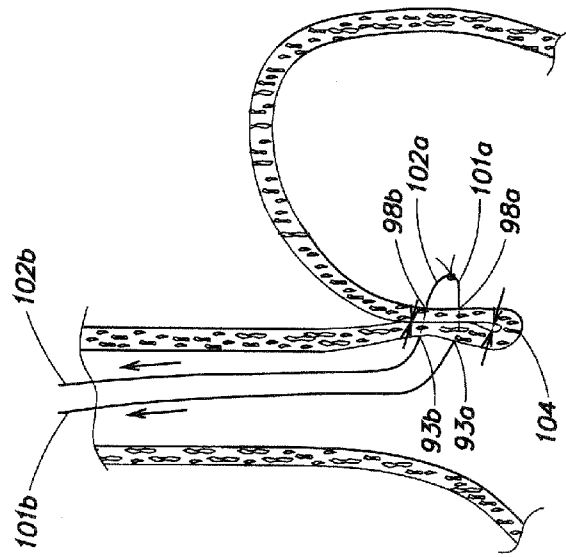


FIG. 22



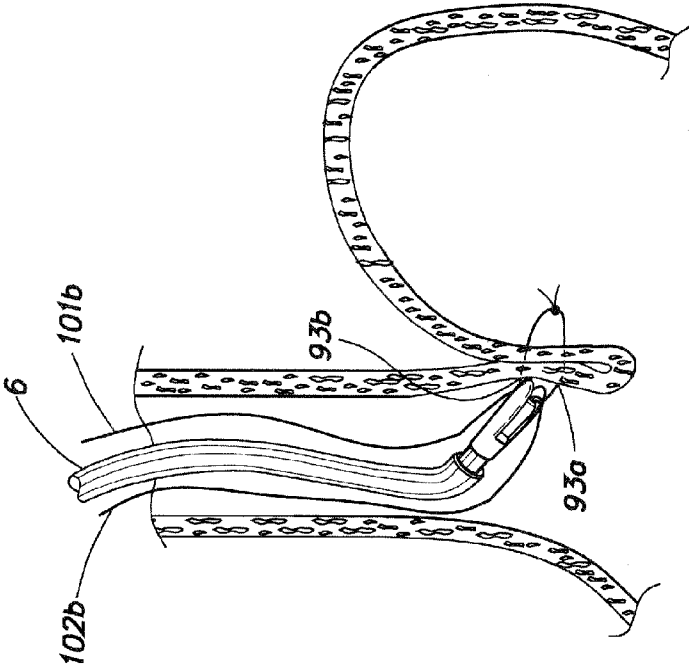


FIG. 24

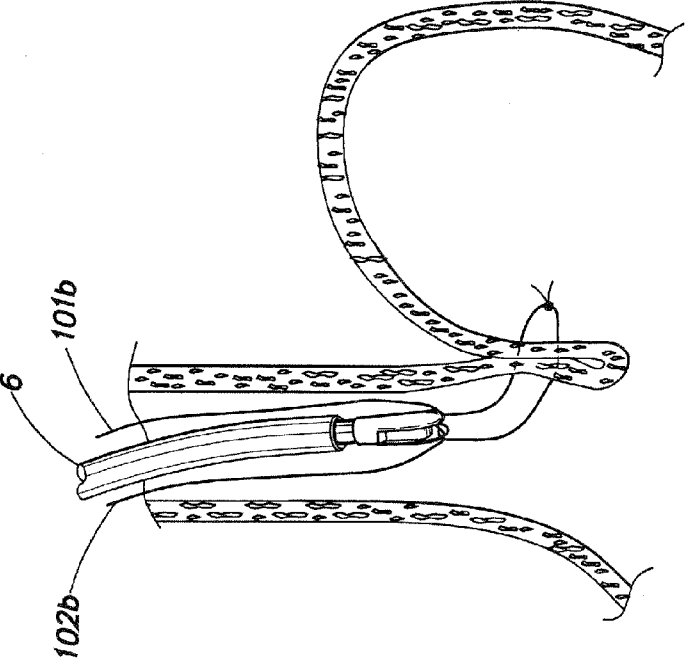


FIG. 25

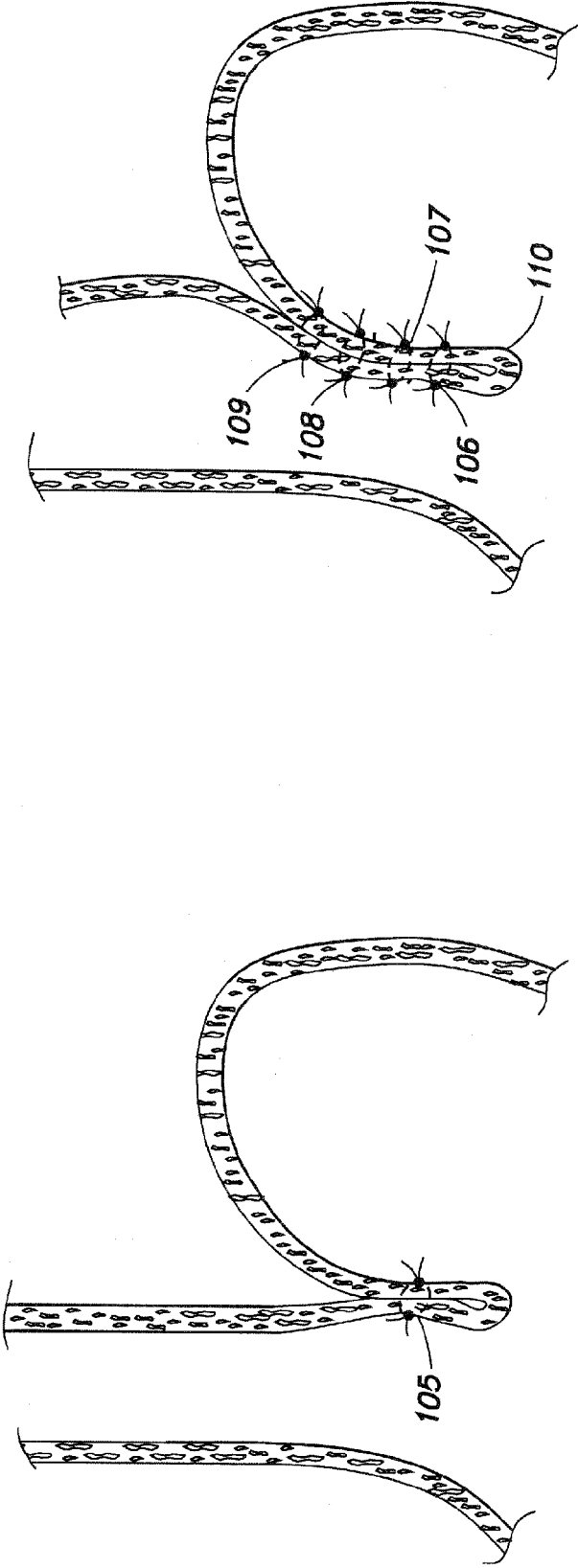


FIG. 27

FIG. 26

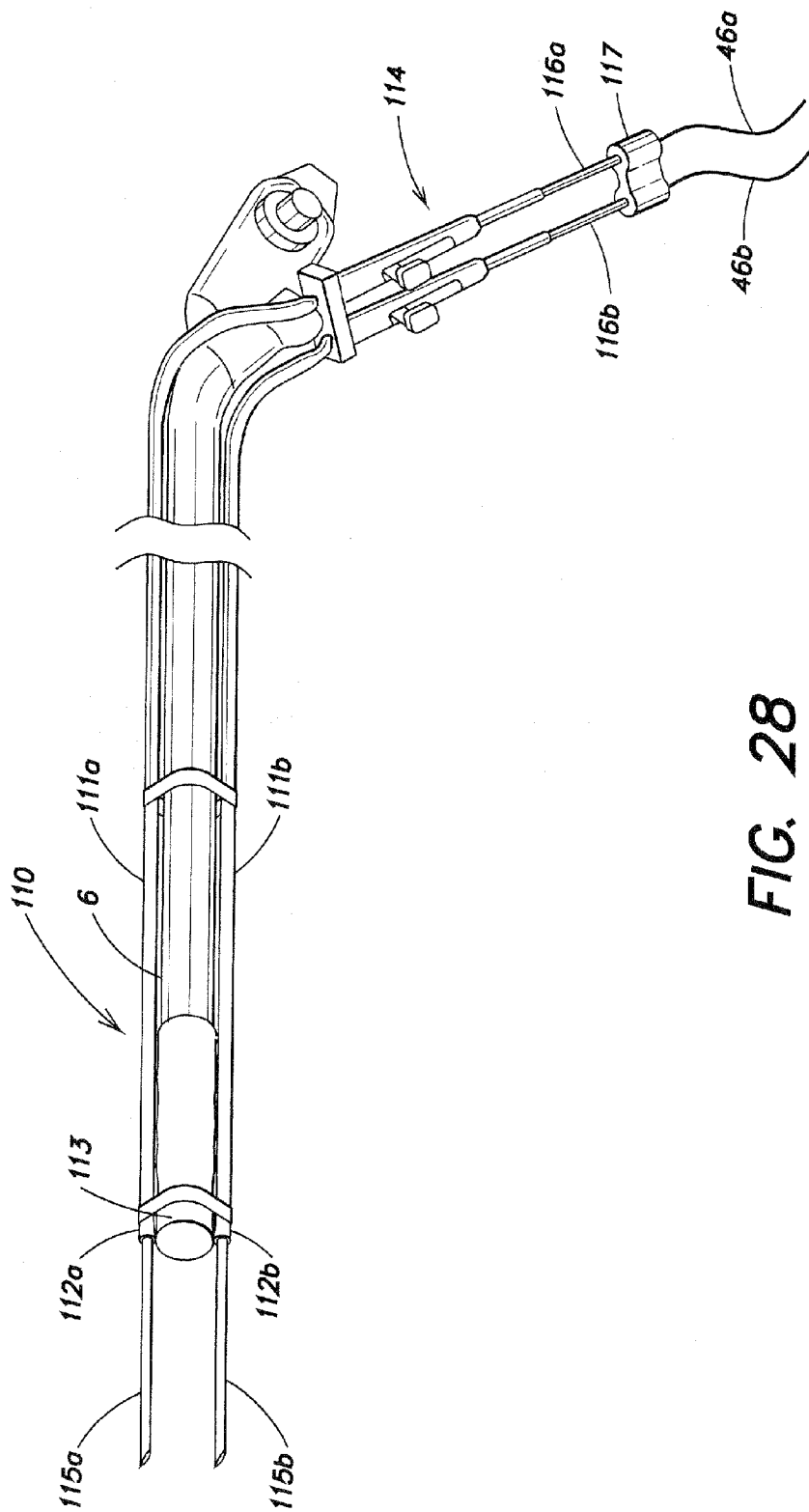


FIG. 28

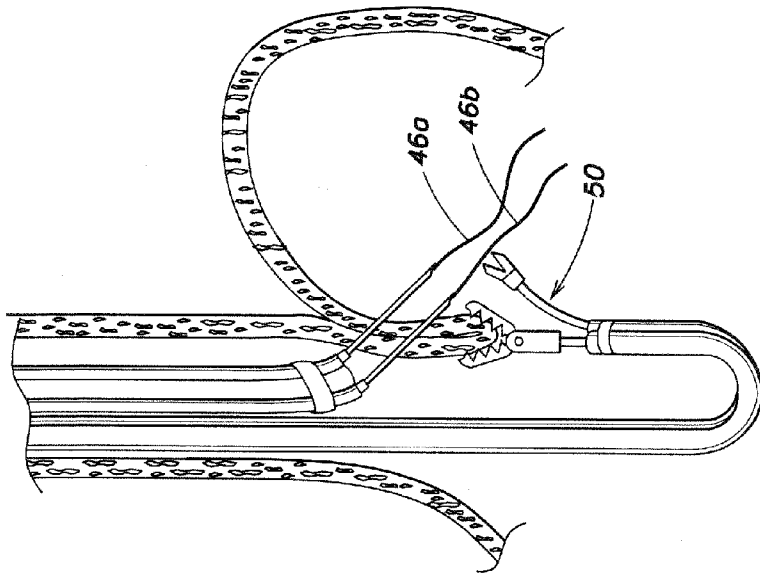


FIG. 29

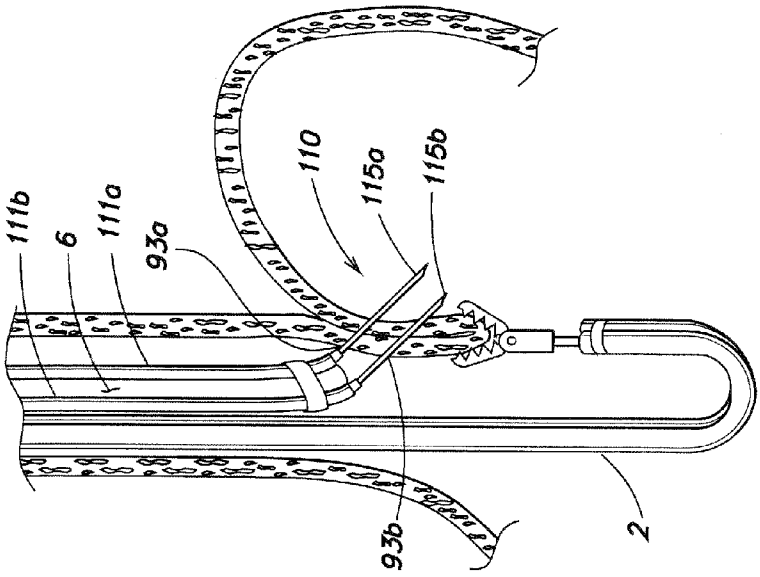
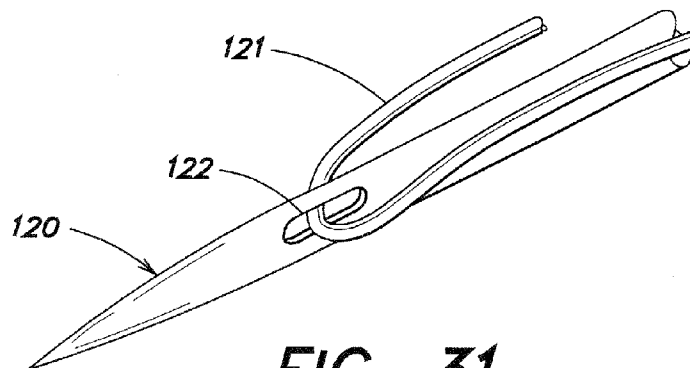
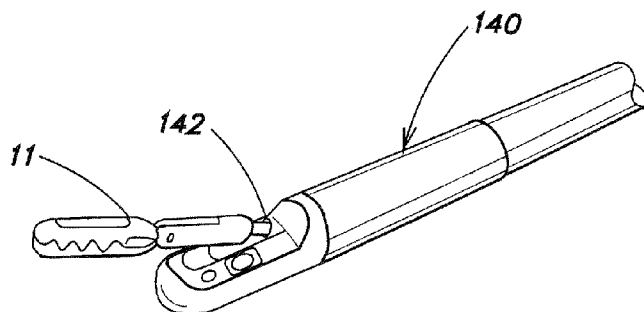


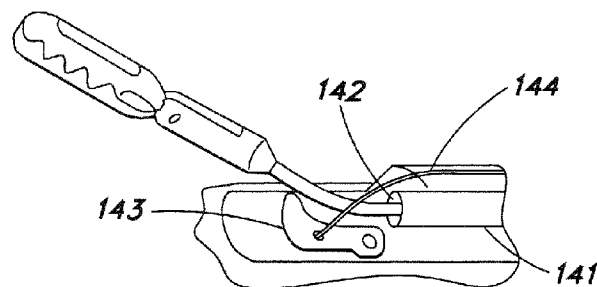
FIG. 30



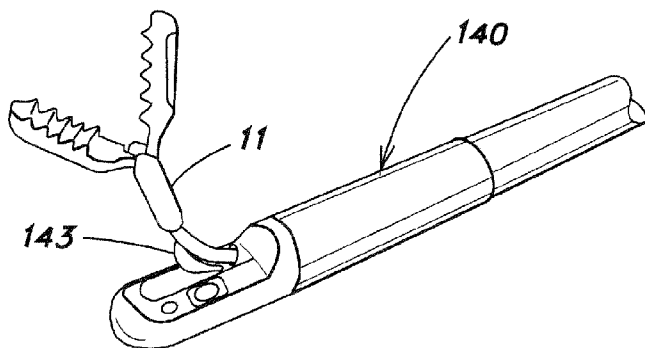
**FIG. 31**



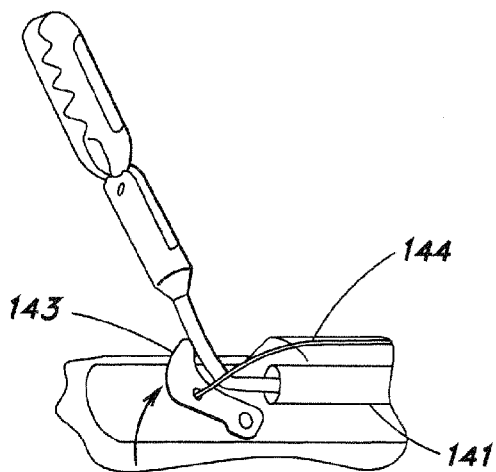
**FIG. 32**



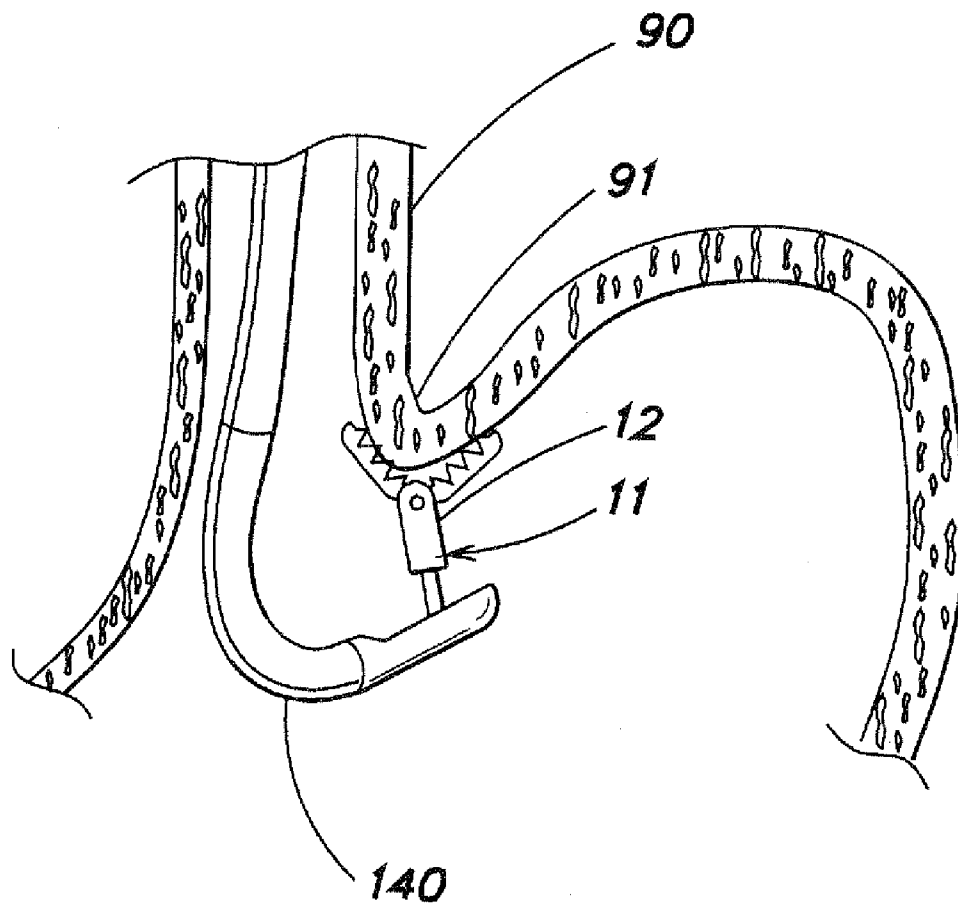
**FIG. 33**



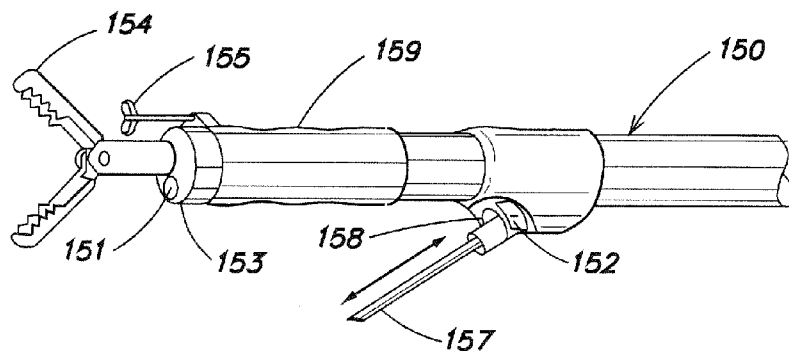
**FIG. 34**



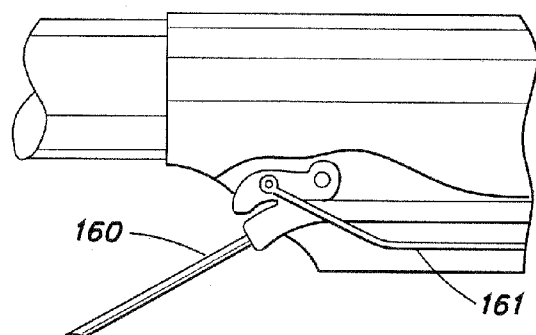
**FIG. 35**



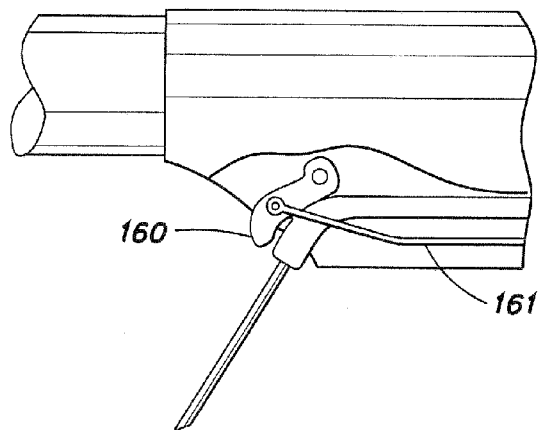
**FIG. 36**



**FIG. 37**

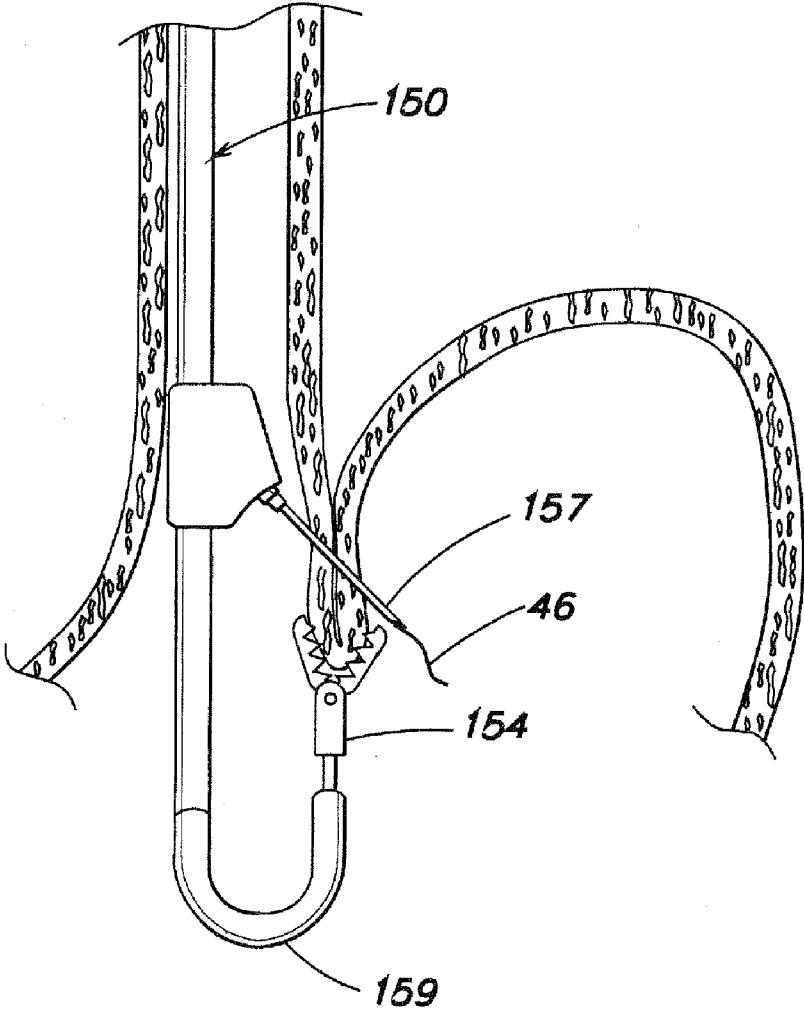


**FIG. 38**

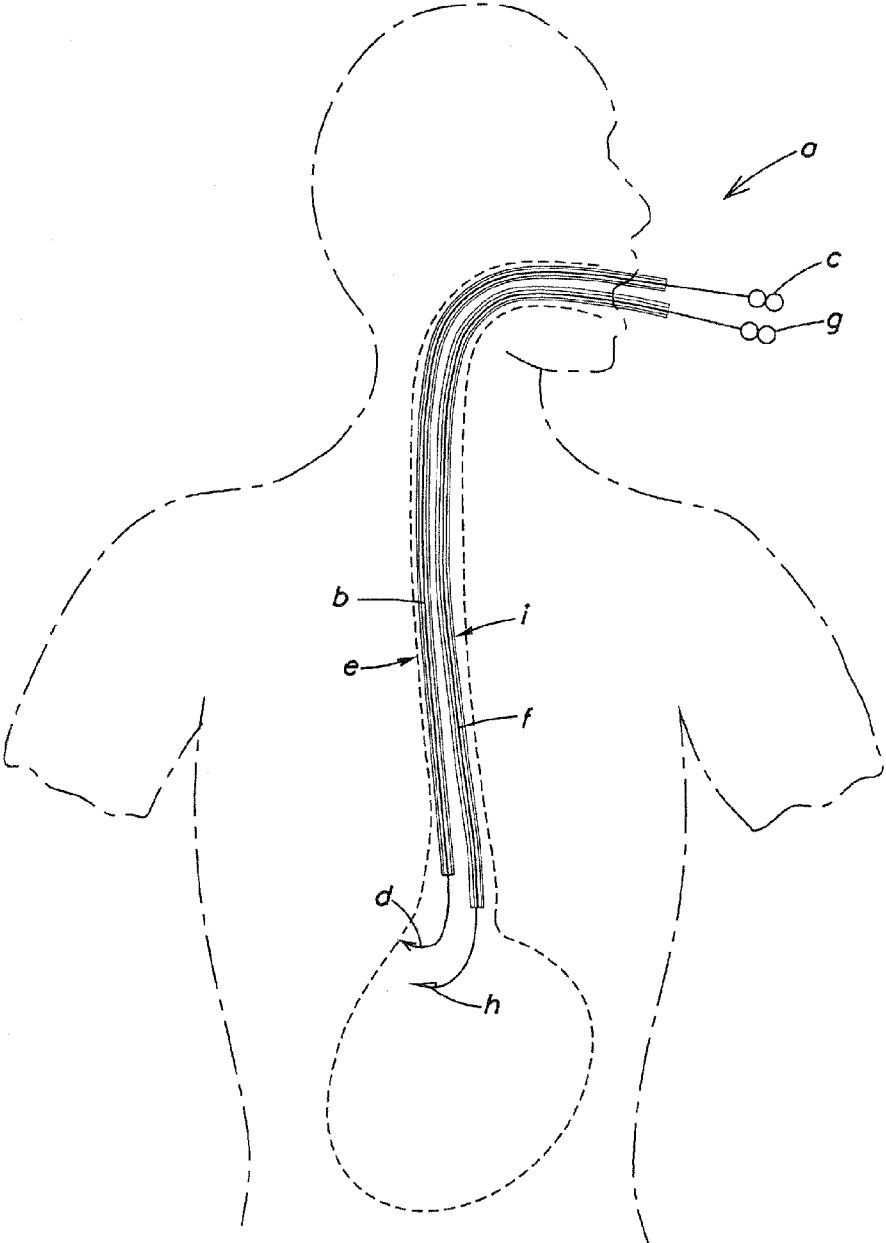


**FIG. 39**

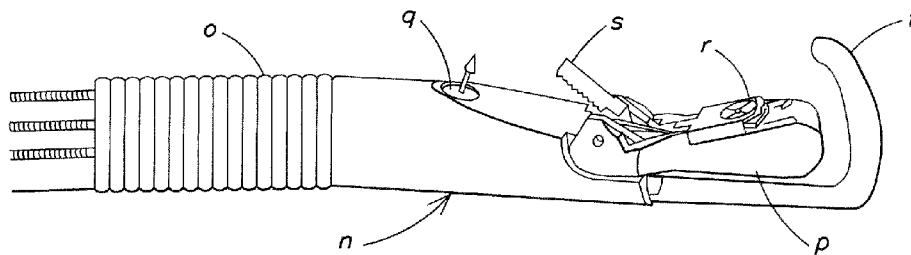




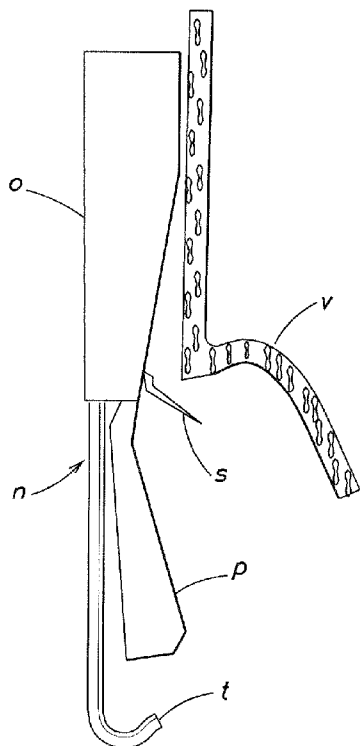
**FIG. 40**



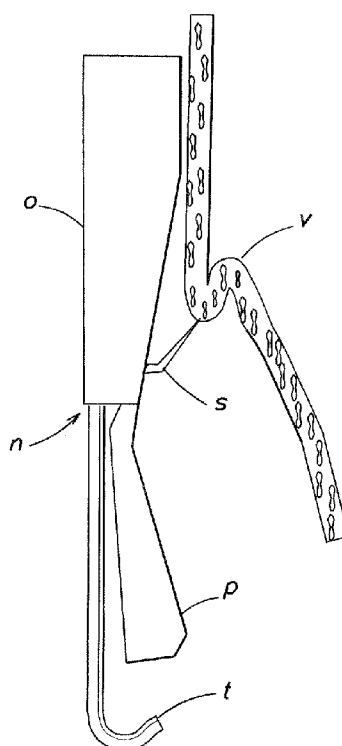
**FIG. 41**  
(Prior Art)



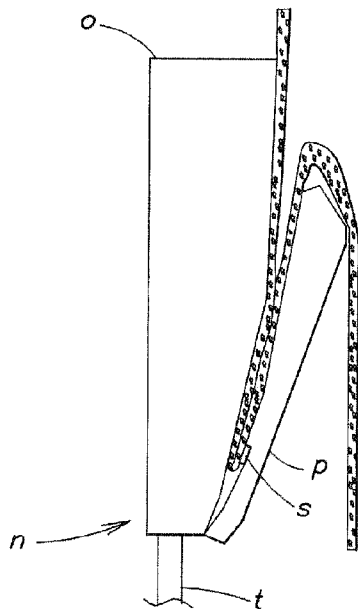
**FIG. 42**  
(Prior Art)



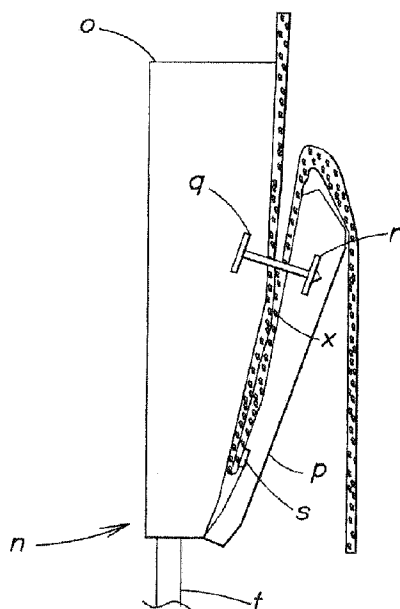
**FIG. 43**  
(Prior Art)



**FIG. 44**  
(Prior Art)



**FIG. 45**  
(Prior Art)



**FIG. 46**  
(Prior Art)

**ENDOSCOPE AND ENDOSCOPIC SUTURING INSTRUMENT FOR TREATMENT OF GASTROESOPHAGEAL REFLUX DISEASE**

**CROSS-REFERENCE TO RELATED APPLICATIONS**

[0001] The present application is a divisional application of U.S. application Ser. No. 10/998,242, filed Nov. 24, 2004, which is a continuation application of U.S. application Ser. No. 09/909,980, now U.S. Pat. No. 6,921,361, filed Jul. 23, 2001, both of which are incorporated herein by reference, and which claims the priority of U.S. Provisional Patent Application Ser. No. 60/220,204, filed Jul. 24, 2000.

**FIELD OF INVENTION**

[0002] The present invention relates to an apparatus and a method for forming an artificial valve to treat gastroesophageal reflux disease (GERD).

**BACKGROUND OF THE INVENTION**

[0003] The incidence of GERD has increased recently. The main symptoms of GERD are heartburn and mucosal breaks in the esophagus. Although it is a benign disease, GERD is accompanied by serious pain, and often requires treatment. The main cause of GERD is decreased function of the lower esophageal sphincter (LES) at the bottom of the esophagus followed by reflux of acid into the esophagus.

[0004] GERD is usually treated by administration of acid secretion controlling agents such as proton-pump inhibitors. Moderate GERD will improve and may be treated completely by medication. If, however, the LES function is damaged seriously or if anatomic problems such as hiatal hernias exist, treatment with medication is less effective, and becomes costly over an extended period of time.

[0005] Therefore, cases of serious GERD are often treated surgically. Effective surgical methods—including Nissen fundoplication or the Toupet method—are known and applied widely. With this method, the LES is wrapped by the stomach wall to improve its function.

[0006] This method has been proven highly effective. Recently, laparoscopic surgery techniques were used with this method as a less invasive treatment. Because there are many patients, and GERD is a benign disease, these less invasive treatments are desirable.

**DESCRIPTION OF THE RELATED ART**

[0007] FIG. 41 depicts a tool for transoral treatment of GERD, disclosed in U.S. Pat. No. 5,887,594. This instrument a comprises a piercing device e having an elongated portion b, a manipulation section c and a hook portion d; and a securing device i having a connector f, a manipulation section g and a securing mechanism h. The piercing device e is inserted from the mouth to the stomach of a patient, and pulled up to the esophagus, with the hook portion d fixed at the upper stomach thereby forming a fold of tissue (not shown). Then, the securing device i is inserted into the esophagus of the patient, and the securing mechanism h fixes the fold consisting of the upper stomach and the esophagus. When the fold is fixed, the intermediate portion is compressed to inward to form valve (not shown).

[0008] FIGS. 42 to 46 depict another transoral treatment method of GERD, disclosed in International Patent Publication No. WO99/22649. An instrument n has a rotatable fastener head p, which is rotatable at the distal end of a flexible tube o, and the rotatable fastener head p and portion of the flexible tube o that can touch the rotatable fastener head p have a male fastener q and a female fastener r, respectively. The flexible tube o has a rotatable grasper s at the distal end, and an opening for an endoscope t to be inserted throughout the flexible tube o. First, the flexible tube o is inserted from the mouth to the stomach of the patient. The rotatable grasper s is drawn into contact with a junction v between the stomach and the esophagus. The rotatable grasper s is operated to hold the junction v. Next, the flexible tube o is advanced downward to suspend the junction v. The rotatable fastener head p is operated to penetrate the junction v with the male fastener q to engage with the female fastener r. Thus, the junction v and the middle part are compressed to be protruded inward to form a protrusion x.

[0009] In the composition disclosed in U.S. Pat. No. 5,887,594, the hook portion d of the piercing device e needs to be fixed to the stomach and pulled. The gastric wall, however, is thicker than the esophagus, and is divided into three regions: the inner mucous membrane; the middle proper muscularis; and the outer serous membrane. In particular, a space between the mucous membrane and the proper muscularis has high movability. To form a protrusion into a valve, tissue including the proper muscularis should be compressed and lifted up. The hook portion d only takes the mucous membrane and cannot include the proper muscularis below it. Thus, the valve formed in this application is not large and thick enough to prevent reflux satisfactorily.

[0010] In the apparatus disclosed in International Patent Publication WO99/22649, the rotatable grasper s is integral to the flexible tube o, which makes it difficult to touch the target tissue. The field of view of the endoscope t is blocked by the rotatable fastener head p, which makes difficult for the rotatable grasper s to hold and suspend the junction v between the stomach and the esophagus. Because the position between the rotatable grasper s, the male fastener q, and the female fastener r is fixed, the size of a protrusion x is limited. It is desirable, however, to form a protrusion of varying size depending on the degree of severity of GERD. The difficulty of passing food has already been reported as a complication of artificial cardia in Nissen fundoplication, and is likely to happen with an excessively large protrusion x. Even much a smaller protrusion x is effective for the treatment of the moderate GERD. With this apparatus, treatment is not flexible enough to allow a small protrusion to facilitate food flow in the case of moderate GERD.

**SUMMARY OF THE INVENTION**

[0011] The first object of the present invention is to provide the apparatus and method for forming a valve including the proper muscularis below the mucous membrane to prevent gastroesophageal reflux effectively.

[0012] The second object of the present invention is to provide the apparatus and method for holding and suspending the junction between the stomach and the esophagus using a holding device extending out of the distal end of an endoscope to improve the ease of the operation for forming the protrusion.

[0013] The third object of the present invention is to provide the apparatus and method for forming a valve of varying size by using a separate holding device and a needle to achieve the flexible treatment method, which may be modified due to the degree of GERD severity.

[0014] According to the present invention, an apparatus for forming an artificial valve to treat gastroesophageal reflux disease comprising a first endoscope to be inserted from the mouth into a body cavity; a holding device extending out of the distal end of the first endoscope and holding a point of a digestive wall where the artificial valve is formed; a first needle disposed the oral side of the point, retractable along the first endoscope and including a sharp end for penetrating from the oral side of the point to the anal side of the point; a suture passing through following the first needle; and a suture retaining device having a grasping section for grasping the suture after it has passed through the digestive wall.

[0015] According to another aspect of the present invention, a treatment method for forming an artificial valve to treat gastroesophageal reflux disease comprises the following steps. Inserting an endoscope from the mouth substantially adjacent to a point of a digestive wall where the artificial valve is to be formed. Holding a point with a holding device extending out of the distal end of the endoscope. Pulling down the point held by holding device. Penetrating the digestive wall from the oral side of the point to the anal side of the point by a needle positioned along the endoscope. Passing a suture through following the needle. Shortening the digestive wall with the suture to form the artificial valve. Fixing the end of the suture to maintain the artificial valve.

#### BRIEF DESCRIPTION OF THE DRAWINGS

[0016] FIG. 1 depicts an arrangement of the first embodiment of the present invention including a first endoscope and a second endoscope.

[0017] FIG. 2 depicts a holding device of the first embodiment.

[0018] FIG. 3 depicts a detail view of the distal end of the holding device of the first embodiment.

[0019] FIG. 4 depicts a detail view of a pair of jaws of the holding device of the first embodiment.

[0020] FIG. 5 depicts an exploded view of the connection between a sheath and a manipulation section of the holding device of the first embodiment.

[0021] FIG. 6 depicts a cross-section of the connection depicted in FIG. 5.

[0022] FIG. 7 depicts a needle tool of the first embodiment.

[0023] FIG. 8 depicts a needle of the first embodiment.

[0024] FIG. 9 depicts the needle tool, a needle, and a suture in a second endoscope of the first embodiment.

[0025] FIGS. 10A and 10B depict a detail view of the distal end of a suture retaining device of the first embodiment.

[0026] FIG. 11 depicts a knot pusher of the first embodiment.

[0027] FIGS. 12 to 27 depict steps of a treatment method using the first embodiment.

[0028] FIG. 28 depicts a second embodiment of the present invention.

[0029] FIGS. 29 to 30 depict a treatment method using the second embodiment.

[0030] FIG. 31 depicts a third embodiment of the present invention.

[0031] FIGS. 32 to 35 depict a fourth embodiment of the present invention.

[0032] FIG. 36 depicts a treatment method using the fourth embodiment.

[0033] FIGS. 37 to 39 depict a fifth embodiment of the present invention.

[0034] FIG. 40 depicts a treatment method using the fifth embodiment.

[0035] FIG. 41 depict FIG. 3 of U.S. Pat. No. 5,887,594.

[0036] FIGS. 42 to 46 depict various figures from PCT Application WO 99/22649.

#### DETAILED DESCRIPTION

[0037] FIG. 1 illustrates the overall configuration of the first embodiment of the present invention. Apparatus 1 comprises a first endoscope 2, holding device 11, which may be holding grasping forceps, forceps, or any other device capable of holding the digestive wall of a body cavity, extendable out of the distal end 3 of the first endoscope 2, a guide 5 running lengthwise on the outer periphery of the first endoscope 2, a second endoscope 6 to be inserted parallel to the first endoscope 2, a needle tool 40 retractable at the distal end 7 of the second endoscope 6, a sheath 84 in which the first endoscope 2 and the second endoscope 6 are retractably inserted, a suture 46 retractably insertable in a lumen 8 of the needle tool 40, suture retaining device 50, which may be forceps, suture grasping forceps, or any other device capable of grasping sutures, to be inserted in a lumen 9 of the guide 5 and movable in relation to the first endoscope 2, and a knot pusher 61 to be used with the first endoscope 2 or second endoscope 6. Each member of the first embodiment is described as follows.

[0038] FIGS. 2 to 6 depict the first endoscope 2 and holding device 11 of the first embodiment. The holding device 11 comprise a distal portion 12, a sheath 14 fixed at the proximal end of the distal portion 12 and inserted in a channel 13 of the endoscope 2, and a manipulation section 15 fixed detachably at the proximal end of the sheath 14 for operating the distal portion 12. In the distal portion 12, a pair of jaws 17a and 17b, which may be forcep jaws, are fixed pivotally with a pin 18 to a cover 16 and via links 19a and 19b to a cable anchor 20. A cable 21 is fixed to the cable anchor 20, and inserted in the sheath 14. The cable 21 is fixed detachably to a sliding part 22 of the manipulation section 15. A slider handle 23 is fixed to the sliding part 22, and is translated lengthwise in relation to the manipulation section 15.

[0039] The distal portion 12 has a larger outside diameter than the channel 13 of the first endoscope 2. The jaws 17a and 17b have a plurality of teeth 24a and 24b for grasping

tissue securely, which engage each other when the jaws *17a* and *17b* are in a closed position. To minimize damage to tissue when it is grasped, the surface of the teeth *24a* and *24b* are smooth with a minimum amount of sharp edges. The jaws *17a* and *17b* have longitudinal grooves *25a* and *25b* to permit tissue to escape when it is grasped securely, and to prevent tissue from collapsing.

[0040] The slider handle *23* has a serrated part *26*, which is retractable. The sliding surface *27* of the manipulation section *15* has serrations *28*. Together the serrated part *26* and the serrations *28* act as ratchet mechanism.

[0041] A hook *30* is fixed to the proximal end *29* of the cable *21*, and is inserted into a hole *31* of the slider handle *23*. Threads *32* are formed vertically in the hole *31*. The hook *30* is fixed in the hole *31* by screwing a knob *33* to engage the hook *30*.

[0042] The sheath *14* has two catches *70* and *71* at the proximal end, which may be arranged diametrically from each other. The manipulation section *15* has an introduction hole *72* in the axial direction at the distal end to accommodate the sheath *14*. Two engagement holes *73* and *74* are disposed within the walls of the introduction hole *72* to engage with the catches *70* and *71*. Outside of each of the engagement holes *73* and *74*, there are deformable latches *75* and *76*, that press the catches *70* and *71* through the engagement holes *73* and *74*.

[0043] FIGS. 7 to 9 depict the second endoscope *6*, needle tool *40*, and suture *46* of the first embodiment. The needle tool *40* comprises a sheath *42* to be inserted in the channel *41* of the second endoscope *6*, a manipulation section *43* disposed at the proximal end of the sheath *42*, a needle *44* sliding in the lumen of the sheath *42*, a grip *45* fixed to the proximal end of the needle *44*, and a suture *46* to be inserted slidably in the lumen of the needle *44*. The needle *44* may be made of stainless steel or any material having sufficient flexibility to withstand proximal pressure and adapt to the bending of the endoscope, such materials include super elastic alloys including nickel titanium alloy. The manipulation section *43* comprises a body *80*, a sheath sliding section *81*, and a needle sliding section *82*, which slides in the longitudinal direction. The distal end of the sheath sliding section *81* is fixed to the proximal end of the sheath *42*. The grip *45* of the needle *44* is fixed detachably to the proximal end of the needle sliding section *82*. The manipulation section *43* has at the distal end a connecting section *49* to be fixed detachably to a channel clasp *48* of the handle *47* of the endoscope *6*.

[0044] The suture *46* may be made of durable, slidable material capable of sliding smoothly in the lumen *8* of the needle *44*, such as nylon monofilament or multifilament coated with fluoroplastics.

[0045] FIGS. 10A and 10B depict the suture retaining device *50* of the first embodiment. The suture retaining device *50* is slidably insertable in the lumen *9* of the guide *5*, which is fixed on the outer periphery of the first endoscope *2*. A distal section *51* has jaws, *52a* and *52b*, which may be forcep jaws with an opening and closing position. The jaws *52a* and *52b* each have a plurality of small protrusions *54a* and *54b* for preventing the suture *46* from slipping off the grasping surfaces *53a* and *53b*. The distal section *51* has, at the proximal end, a sheath *55* following the curve of the first

endoscope *2* and a wire *56* capable of translating longitudinally in the sheath *55*. The wire *56* has a slider handle *57* at the proximal end, and the sheath *55* has a manipulation section *58* at the proximal end. The slider handle and the manipulation section have, like the holding device *11*, a serrated part (not shown) and serrations (not shown), which together act as a ratchet mechanism.

[0046] FIG. 11 depicts a knot pusher *61* comprising a distal end *62*, a sheath *63* to be inserted in the channel *13* or *41* of the first endoscope *2* or second endoscope *6*, and a knob *64* for pressing the distal end *62* in the longitudinal direction. The distal end *62* has a slit *65* for engaging the suture *46*.

[0047] FIGS. 2 to 9 further depict assembly of the first embodiment. The hook *30*, the cable *21*, and the sheath *14* are inserted into the channel *13* from the distal end *3* of the first endoscope *2*. Next, the hook *30*, extending out of the proximal end of the first endoscope *2*, is inserted in the hole *31* of the sliding part *22*. The knob *33* of the slider handle *23* is screwed into the threads *32* in the slider handle *23* to hold and engage the hook *30* with the sliding part *22*. Then, the sheath *14* is inserted in the introduction hole *72* of the manipulation section *15* to deform the catches *70* and *71* inward and diametrically to be housed in the introduction hole *72*. The catches *70* and *71* deform diametrically outward to engage the engagement holes *73* and *74*. At this point, the sheath *14* and the manipulation section *15* are fixed.

[0048] The guide *5* is fixed on the outer periphery *4* of the first endoscope *2* at several points using a medical tape. The suture *46* is inserted in the lumen *8* of the needle tool *40*.

[0049] The grip *45* is pulled proximally so that the needle *44* or the suture *46* is withdrawn in the distal end of the needle tool *40*. The sheath *42* is inserted from the channel clasp *48* of the second endoscope *6* to the channel *41* until the distal end of the sheath *42* extends out of the distal end of the endoscope *6*. Then the body *80* is fixed to the channel clasp *48* of the endoscope *6*.

[0050] FIGS. 12 to 14 depict holding and suspending of the cardia using the apparatus of the first embodiment. The sheath *14* of the holding device *11* is drawn proximally to withdraw only the distal portion *12* in the distal end *3* of the first endoscope *2*. The first endoscope *2* covered by the sheath *84* is inserted into the body cavity of a patient. Because the distal portion *12* is also covered by the sheath *84*, the endoscope *2* can be inserted without any trauma of to the patient's tissue. The first endoscope *2* is inserted into the stomach of the patient, and withdrawn from the sheath *84*, then, the distal end *3* is bent upwards to face the cardia *90*.

[0051] The slider handle *23* is pressed distally against the manipulation section *15* (not shown in FIGS. 12 to 14). The hook *30*, the cable *21*, and the cable anchor *20* are translated distally to rotate the links *19a* and *19b*, and in turn, the jaws *17a* and *17b* around the pin *18* to open the jaws *17a* and *17b*. The sheath *14* is moved forward to bring the jaws *17a* and *17b* into contact with the tissue *91* in the side of the greater curvature of the stomach at the cardia *90*.

[0052] The slider handle *23* is pulled proximally to close the jaws *17a* and *17b*. The tissue *91* is held and pressed by the jaws *17a* and *17b*, but will not collapse to overflow from

the longitudinal grooves **25a** and **25b** or because the teeth **24a** and **24b** are not sharp. The serrated part **26** of the slider handle **23** is extended against the sliding surface **27** of the manipulation section **15**, and engaged with the serrations **28** to limit distal movement of the slider handle **23**. The jaws **17a** and **17b** hold and fix the tissue **91**, once it is held, even if the slider handle **23** or the manipulation section **15** is not held by physician.

[0053] The first endoscope **2** is inserted deeply into the body to suspend the first endoscope **2** and the holding device **11**. The distal portion **12** has a larger outside diameter than the channel **13** of the first endoscope **2**. The jaws **17a** and **17b** are wide and long, and the tissue **91** is suspended and fixed by the jaws **17a** and **17b**.

[0054] FIGS. **15A**, **15B**, **16A** and **16B** depict penetrating the gastric and esophagus walls using the first embodiment. The second endoscope **6** is inserted parallel to the first endoscope **2**. The distal end of the second endoscope **6** is positioned at a point **92** above the junction between the stomach and the esophagus while it is observed by the second endoscope **6**. Then the second endoscope **6** is manipulated to bend the distal end **7** slightly toward the side of the greater curvature of the stomach. The sliding section **81** is moved distally against the body **80** to extend the sheath **42** out of the distal end **7** of the second endoscope **6**, and to press an entering point **93a**.

[0055] The grip **45** is pressed forward to extend the needle **44** out of the sheath **42**. Because the greater curvature of the stomach at the cardia **90** has already been held by the holding device **11** and suspended with the first endoscope **2**, the needle **44** pierces from the entering point **93a** through the mucous membrane **94**, continuing at least through the proper muscularis **95** of the esophagus, then through the proper muscularis **96** of the stomach, and then through the mucous membrane **97** of the stomach, and exiting out of an exiting point **98a** of the cardia.

[0056] Next, the first endoscope **2** is inserted deeper in the body, and the tissue **91** is suspended lower, the needle **44** passes the entering point **93b**, the mucous membrane **94** of the esophagus, the proper muscularis **95** of the esophagus, the abdominal cavity **99**, the serous membrane **100** of the stomach, the proper muscularis **96** of the stomach, the mucous membrane **97** of the stomach, and the exiting point **98b** at the cardia.

[0057] The first endoscope **2** checks that the needle **44** comes out in the stomach.

[0058] FIGS. **17** and **18** depict inserting and pulling the suture with the first embodiment. The suture retaining device **50** is inserted in the guide **5** and extended out in the stomach of the patient. The process is observed by the first endoscope **2**. The suture **46** is pressed in the needle **44**, and extended out in the stomach. With the suture retaining device **50** drawn into contact with the suture **46**, the slider handle **57** is moved forward against the manipulation section **58** to open the jaws **52a** and **52b**. The suture **46** is held by the jaws **52a** and **52b**. The slider handle **57** is moved proximally against the manipulation section **58** to close the jaws **52a** and **52b**. The suture **46** is held by the small protrusions **54a** and **54b** on the grasping surfaces **53a** and **53b** of the jaws **52a** and **52b**. The jaws **52a** and **52b** are designed to minimize the chances that the suture **46** will slip off, or be cut or damaged. When the

serrated part of the slider handle **57** is engaged with the serrations of the manipulation section **58**, distal movement of the slider handle **57** will not be limited. Therefore, the jaws **52a** and **52b** hold and fix the suture **46** with hands-free operation of the slider handle **57** or the manipulation section **58**. Next, the suture retaining device **50** is withdrawn from the guide **5** together with the suture **46**. The serrated part **26** of the holding device **11** is lifted to disengage from the serrations **28**. The slider handle **23** is moved forward to open the jaws **17a** and **17b** to release the tissue **91**.

[0059] The steps illustrated in FIGS. **17** and **18**, and discussed above, are repeated to pass two sutures **46a** and **46b** through the following points: from outside the body, the channel **13** of the first endoscope **2**, the patient tissue of the esophagus and the stomach, inside the guide **5**, outside the body. The endoscopes **2** and **6** are withdrawn with the sutures **46a** and **46b** remaining in the body cavity. The resulting configuration is shown in FIG. **19**.

[0060] FIGS. **19** to **22** depict formation of the artificial valve using the first embodiment. The suture **46a** has ends **101a** and **101b**; the suture **46b** has ends **102a** and **102b**. The ends **101a** and **102a**, which are on the side of the stomach, are tied to each other outside the patient's body. The free ends **101b** and **102b**, which are on the side of the esophagus, are pulled to draw the ends **101a** and **102a** into the body cavity. The ends **101a** and **102b** adjoin, and are fixed at exiting points **98a** and **98b** of the stomach. Then the ends **101b** and **102b** are pulled further to bring the gastric wall near the exiting points **98a** and **98b** close to entering points **93a** and **93b** in the esophagus. Thus, a junction **103** of the stomach and the esophagus between the exiting points **98a** and **98b** and the other entering points **93a** and **93b** is shortened to form an internal protrusion **104**.

[0061] FIGS. **23** to **27** depict fixing the sutures with the first embodiment. The ends **101b** and **102b** of the sutures **46a** and **46b** are tied outside the body to form a knot **105**. The knot pusher **61** is inserted in the channel **41** of the second endoscope **6**, and its distal end **62** is extended out of the distal end of the second endoscope **6**. With the knot **105** engaged on the slit **65**, the second endoscope **6** and the knot pusher **61** are inserted into the body cavity. Then, the ends **101b** and **102b** of the sutures are pulled to move the knot **105** and the second endoscope **6** into the body cavity. As seen in FIG. **25**, when the knot **105** reaches the entering points **93a** and **93b** of the esophagus, the distal end **62** is pressed against the entering points **93a** and **93b** while the ends **101b** and **102b** are pulled to fix the knot **105**. The above step is repeated several times to prevent the knot **105** from loosening. After the knot **105** is fixed firmly, the second endoscope **6** and the knot pusher **61** are withdrawn out of the body cavity. The excess sutures **46a** and **46b** beyond the knot **105** are cut using endoscopic scissors (not shown), and are collected to finish the process. Depending on the patient's symptoms, the above process will be repeated to form a plurality of stitches **106** to **109**, as illustrated in FIG. **27**, to form a larger protrusion.

[0062] The holding device **11** inserted in the first endoscope **2** allows suspension of the tissue **91** while it is held and fixed securely. Because the distal portion **12** is formed larger than the channel **13** of the endoscope **2**, the jaws **17a** and **17b** are long and wide enough to hold and suspend a large area of the tissue **91** without damaging it. Therefore,



the needle **44** can pierce deep into the proper muscularis. A large protrusion including the proper muscularis of the stomach and the esophagus is formed as artificial valve for preventing reflux effectively.

[0063] Because the holding device **11** extends out of the distal end of the endoscope **2**, the jaws **17a** and **17b** touch the tissue **91** easily while it is observed by the first endoscope **2**. The process is simple for the operator to perform, and requires a short time.

[0064] Because both the second endoscope **6** and the needle tool **40** are provided separately from both the first endoscope **2** and the holding device **11**, the operator independently controls suspension of the cardia and the positions of the entering points **93a** and **93b** to form valves of varying size according to the patient's particular symptoms.

[0065] In the first embodiment, the second endoscope or the needle is provided separately from the first endoscope or the fixing means. The operator controls at discretion suspension of the tissue or the entering point of the needle to form a valve of different size according to the symptom of a patient.

[0066] FIGS. **28** to **30** depict the second embodiment of the present invention. The same components as the first embodiment are indicated by the same numbers, and their description will be omitted.

[0067] In the second embodiment, a needle tool **110** is composed as follows. Two sheaths **111a** and **111b** are fixed at the distal ends **112a** and **112b** parallel to the distal end **113** of the second endoscope **6**. The sheaths **111a** and **111b** are fixed at the proximal portion on the outer periphery of the second endoscope **6** using medical tape at several points. The two sheaths **111a** and **111b** are fixed to the manipulation section **114** and accommodate needles **115a** and **115b**, which slide inside. Grips **116a** and **116b** are fixed to the proximal ends of the needles **115a** and **115b** and connected to connecting section **117** which is detachable.

[0068] After the first endoscope **2** or the holding device **11** holds and suspends the tissue **91**, the endoscope **6** and the needle tool **110** fixed to the endoscope **6** are inserted into the body cavity of a patient. The endoscope **6** is operated to bring the distal ends of the sheaths **111a** and **111b** to contact with the entering points **93a** and **93b** and press the grips **116a** and **116b** to pierce the needles **115a** and **115b**.

[0069] The sutures **46a** and **46b** extend out of the needles **115a** and **115b** and are held and collected by the suture retaining device **50**.

[0070] In addition to the features of the first embodiment, the second embodiment also is capable of inserting two sutures **46a** and **46b** are inserted at one time. In contrast, using the first embodiment an operator must set the appropriate direction and position of the second entering point **93b** relative to the first entering point **93a**. This takes more time and is more difficult to perform. The second embodiment is simpler in operation and takes much shorter time than the first embodiment because the two sutures **46a** and **46b** are inserted parallel to a certain distance at one time.

[0071] FIG. **31** depicts the third embodiment of the present invention. The same components as the first embodiment are indicated by the same numbers, and their description will be omitted.

[0072] In the third embodiment, a needle **120** does not have a lumen. Instead, a suture **121** is inserted and fixed in a through hole **122** of the needle **120**.

[0073] The needle **120** pierces the tissue with the suture **121** inserted and fixed in the through hole **122**. The suture grasping forceps **50** pulls the suture **121** out of the through hole **122** and removed through the guide **5** out of the body.

[0074] In addition to the effect of the first embodiment, because it is not necessary to insert the suture **121** in the needle, the needle **120** is thinner than the hollow needle **44** in the first embodiment. The needle **120** can be tapered to have a sharp tip, which pierces the tissue with smaller force to improve operability.

[0075] FIGS. **32** to **36** depict the fourth embodiment of the present invention. The same components as the first embodiment are indicated by the same numbers, and their description will be omitted.

[0076] In the fourth embodiment, an endoscope **140** has an optical system capable of viewing in the side direction. A channel **141**, which opens on the side, has an elevator **143** near a distal exit hole **142** for changing the direction of a tool, such as the holding device **11**, as it exits the distal exit hole **142**. The orientation of the tool exiting the distal exit hole **142** can be changed from the axial (axis of the endoscope **140**) direction to the side direction by advancing or withdrawing a wire **144** fixed to the elevator **143**.

[0077] The holding device **11** is mounted to the endoscope **140** and inserted into the stomach of a patient. The distal end of the endoscope **140** is rotated by about 90 degrees to observe the cardia **90**. The wire **144** is pulled to rotate and lift the elevator **143**, thus directing the distal portion **12** of the grasping forceps toward the cardia. The grasping forceps **11** are operated to grasp the target tissue **91**.

[0078] In addition to the effect of the first embodiment, without inversion of the endoscope **140** in the stomach, the front view of the cardia **90** is observed using the endoscope **140** and the holding device **11** grasps and fixes the target tissue. Therefore, even if a patient has lost a part of the stomach due to another disease, and the stomach is too small to allow inversion of the endoscope **2**, the present invention is effective to treat gastroesophageal reflux disease.

[0079] FIGS. **37** to **40** depict the fifth embodiment of the present invention. The same components as the first embodiment are indicated by the same numbers, and their description will be omitted.

[0080] In the fifth embodiment, the first and second endoscopes **2** and **6** are replaced by an integrated endoscope **150**. The endoscope **150** has a first optical system **151** and a second optical system **152**. The endoscope **150** has the first optical system **151** and holding device **154** at the distal end **153**. A suture retaining device **155** is mounted retractably at the distal end **153**.

[0081] The second optical system **152** as well as an exiting hole **158** of a needle **157** is provided at the proximal portion of the distal bendable section **159** of the endoscope **150** and is movable in the longitudinal direction. The exiting hole **158** is disposed near the elevator **160**, and is rotated by a wire **161** fixed to the elevator **160** to change the exiting direction.

[0082] The endoscope 150 is inserted into the body of a patient until the distal end 153 enters the stomach. The endoscope 150 is manipulated to bend the distal bending section 159 to invert the distal end 153 so that it faces a direction substantially upwards. After the first optical system 151 observes the cardia 90, an actuator opens grasping forceps 154 to touch the tissue 91. Then the actuator closes the forceps 154 to fix the tissue 91. Next, the endoscope 150 is advanced deeper to suspend the cardia 90.

[0083] The second optical system 152 and the exiting hole 158 are moved in the longitudinal direction. While the area above the junction between the stomach and the esophagus is observed, the elevator 160 is operated to bring the exiting hole 158 into contact with the entering point 93. The needle 157 pierces the tissue and comes out of the exiting hole 158.

[0084] The suture 46 is extended out of the needle 157, and held and fixed by the suture retaining device 155 which extends out of the distal end 153 under observation of the first optical system 151.

[0085] With the suture 46 remaining in the tissue, the endoscope 150 is withdrawn.

[0086] The effects of the fifth embodiment are similar to those of the first embodiment. In addition, because only the integrated endoscope 150 is inserted into a patient (as opposed to inserting a first endoscope 2 and a second endoscope 6 as with the first embodiment), the device is operated by one operator, and treatment is simple and takes a shorter time.

What is claimed is:

- 1. An apparatus for forming an artificial valve to treat gastroesophageal reflux disease, comprising:
  - a sheath which is adapted to be orally inserted into a body cavity, and which has having proximal and distal sections and a lumen extending therethrough;
  - an endoscope which has an observation system, and which is adapted to be orally inserted into a body cavity and is slidably positioned within said sheath;
  - a holding device extending from said sheath, the holding device comprising a distal end portion adapted to hold a point of a digestive wall of the body cavity where the artificial valve is to be formed;
  - a first needle which is provided outside of the endoscope and is not mechanically connected to said holding device, and which is moveable outside of the endoscope along a lengthwise direction of the first needle relative to the endoscope for penetrating the digestive wall; and
  - a binding member adapted to pass through the digestive wall following said first needle.
- 2. The apparatus according to claim 1, wherein the first needle has a hollow space disposed therein for engaging said binding member.
- 3. The apparatus according to claim 1, wherein said holding device is adapted to hold a junction of a stomach and

an esophagus, and the first needle is adapted to be positioned at an oral side of the junction.

4. The apparatus according to claim 1, further comprising a second needle assembly which is provided outside of the endoscope and is not mechanically connected to said holding device, wherein said second needle is spaced apart from said first needle by a fixed distance and is arranged substantially in parallel with the first needle.

5. The apparatus according to claim 4, wherein the second needle has a hollow space disposed therein for engaging said binding member.

6. The apparatus according to claim 4, wherein said holding device is adapted to hold a junction of a stomach and an esophagus, and the second needle is adapted to be positioned at an oral side of the junction.

7. An apparatus for forming an artificial valve to treat gastroesophageal reflux disease, comprising:

a sheath which is adapted to be orally inserted into a body cavity, and which has proximal and distal sections and a lumen extending therethrough;

an endoscope which has an observation system, and which is adapted to be orally inserted into a body cavity and to be slidably positioned within said sheath;

a holding device extending from said sheath, the holding device comprising a distal end portion adapted to hold a point of a digestive wall of the body cavity where the artificial valve is to be formed;

a first needle which is provided outside of the endoscope and is not mechanically connected to said holding device, and which is moveable outside of the endoscope along a lengthwise direction of the first needle relative to the endoscope for penetrating the digestive wall; and

a tissue fastener adapted to pass through the digestive wall following said first needle.

8. The apparatus according to claim 7, wherein the first needle has a hollow space disposed therein for engaging said binding member.

9. The apparatus according to claim 7, wherein said holding device is adapted to hold a junction of a stomach and an esophagus, and the first needle is adapted to be positioned at an oral side of the junction.

10. The apparatus according to claim 7, further comprising a second needle assembly which is provided outside of the endoscope and is not mechanically connected to said holding device, wherein said second needle is spaced apart from said first needle by a fixed distance and is arranged substantially in parallel with the first needle.

11. The apparatus according to claim 10, wherein the second needle has a hollow space disposed therein for engaging said binding member.

12. The apparatus according to claim 10, wherein said holding device is adapted to hold a junction of a stomach and an esophagus, and the second needle is adapted to be positioned at an oral side of the junction.

\* \* \* \* \*