

[72] Inventors **Lou F. Marks;**  
**Bela G. Szabo, Pittsburgh, Pa.**  
 [21] Appl. No. **830,053**  
 [22] Filed **June 3, 1969**  
 [45] Patented **Mar. 30, 1971**  
 [73] Assignee **Bruce Plastics, Inc.**  
**Moon Run, Pa.**

[56]		References Cited	
UNITED STATES PATENTS			
2,780,372	2/1957	Covitt et al. ....	74/88X
3,109,687	11/1963	Dereng.....	312/244
3,192,004	6/1965	Whitney.....	312/244
3,223,072	12/1965	Bross.....	74/88X
3,447,197	6/1969	Szabo.....	16/115

Primary Examiner—Paul R. Gulliam  
 Attorney—Samuel Lebowitz

- [54] **EXTENSIBLE AND RETRACTABLE HANDLE ASSEMBLY WITH LATCHING MEANS THEREFOR**  
**11 Claims, 8 Drawing Figs.**
- [52] U.S. Cl. .... **312/244,**  
 16/110, 16/115, 190/39, 190/57, 220/94, 222/465
- [51] Int. Cl. .... **A47b 95/02,**  
 A47j 45/00, A45c 13/76
- [50] Field of Search ..... **312/2.44;**  
 16/115, 110; 190/39, 57; 220/94, 96; 222/465;  
 74/88; 292/(arl.)

**ABSTRACT:** An extensible and retractable handle assembly for portable cases, and the like, which is spring biased to its extended operative position and which is moved to its inoperative position by an inward movement of the handle, in which position the same is retained by a latching assembly comprising a rotary member, which member is adapted to be rotated by the reciprocating movements of the handle. An inward movement of the handle for a slight extent in the same direction as the previous movement affects the rotary member and the latching device to effect the release of the handle, which is extended by the spring biasing means acting thereon.

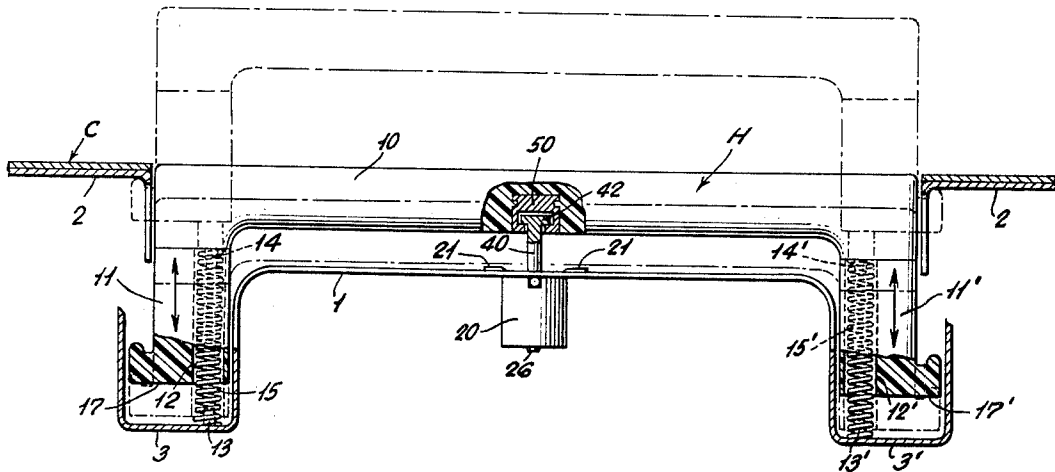

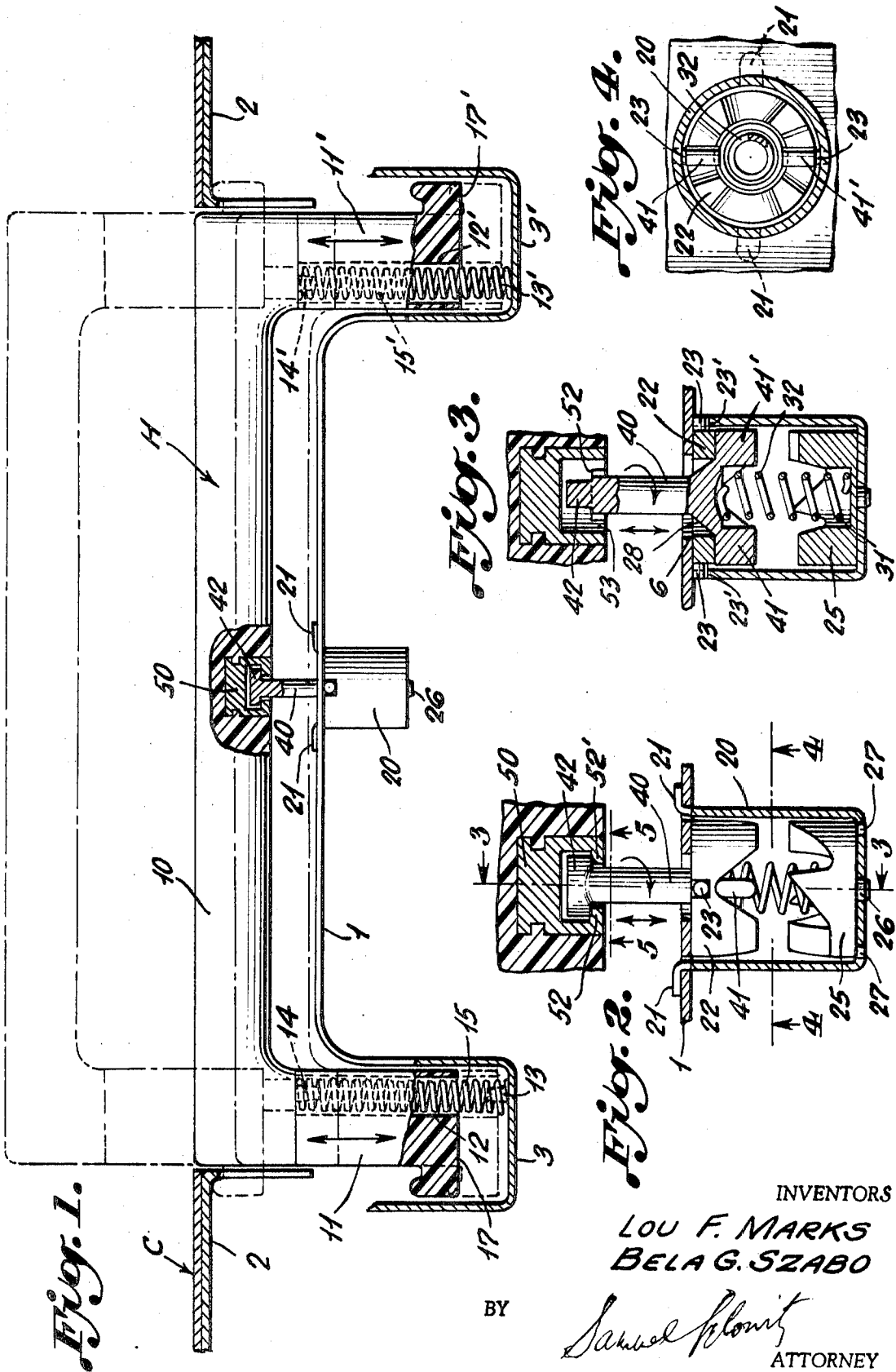

*Fig. 1.*

*Fig. 4.*

*Fig. 3.*

*Fig. 2.*

INVENTORS

LOU F. MARKS  
BELA G. SZABO

BY

*Samuel Plonit*

ATTORNEY

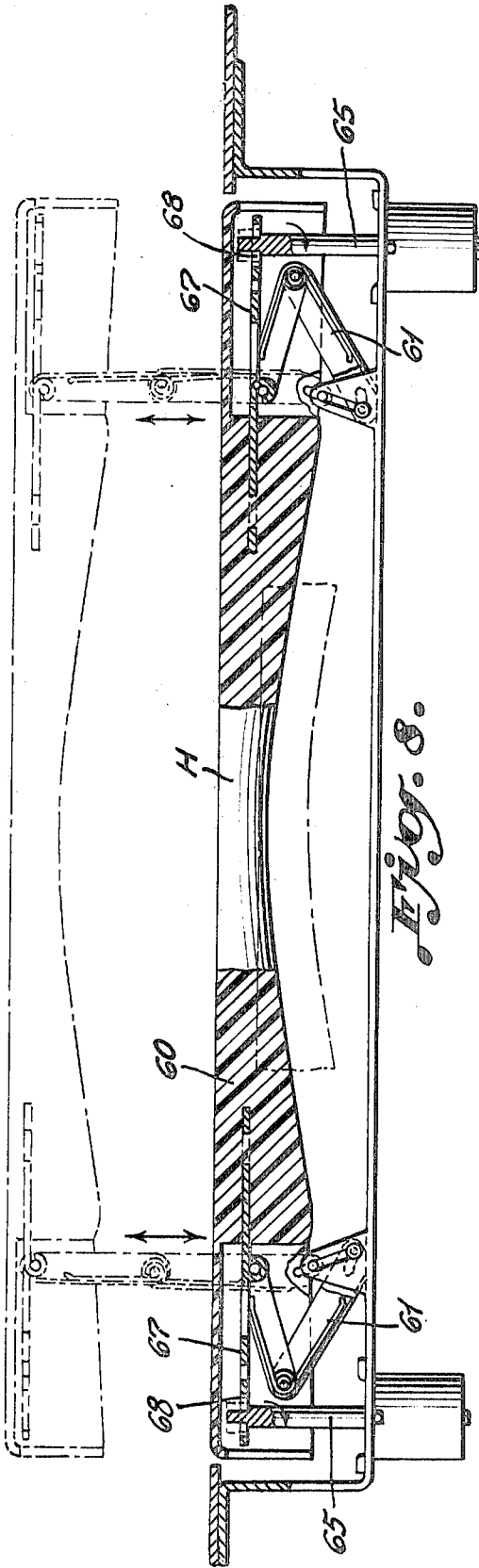

Fig. 8.

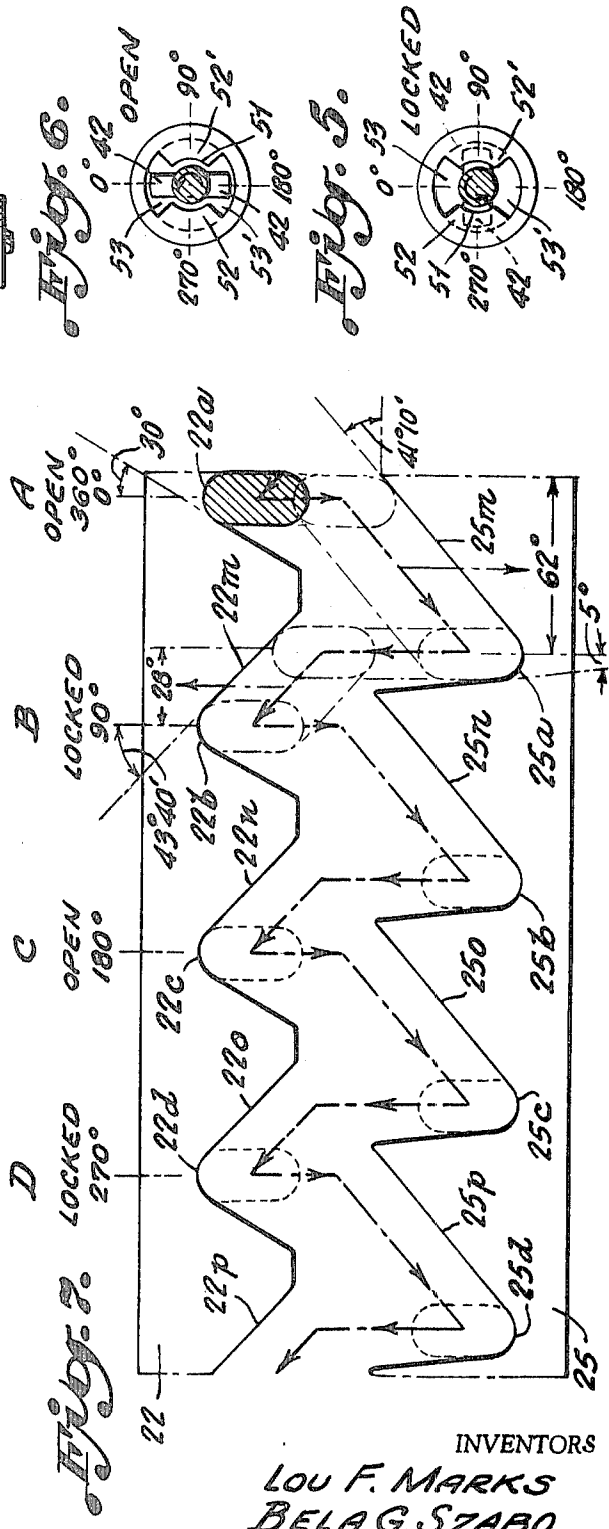

Fig. 2.

Fig. 6.

Fig. 5.

INVENTORS

LOU F. MARKS  
BELA G. SZABO

BY

*Samuel Shovitz*  
ATTORNEY

**EXTENSIBLE AND RETRACTABLE HANDLE ASSEMBLY  
WITH LATCHING MEANS THEREFOR**

This invention relates to an extensible and retractable handle assembly for portable cases of all types, which is adapted to be moved from its extended operative position to its retracted inoperative position in close proximity to the body of the case by a simple pressing movement of the handle towards the case. The return of the handle to its extended position is effected by a like movement, by releasing a spring biasing force which moves the handle outwardly.

It is the object of the present invention to provide a rugged and reliable handle assembly for easy mounting on portable cases and containers of all types, which permits the positioning of the handle in its either retracted or stored position, or in its extended and operative position by a simple pressing movement of the handle towards the case. When the handle is in its inoperative position, a slight pressure thereon causes it to be extended by a spring-biasing means therefor in a rapid manner, which functions as a "popup handle."

It is a further object of the invention to provide a compact latching mechanism which is connected to the portable case and the handle mechanism, which is operative alternatively to latch the handle in stored position, and to release it into raised position where it is convenient as a hand-hold for carrying the portable case, or where it is extended to a height to render it readily manipulatable for further extension to bring it into a more extended position for the accommodation of the hand.

It is another object of the invention to simplify handles for portable cases which may be snapped into nested position by the depression of the handle itself, and which is similarly released for extension. This construction presents a marked simplification over such arrangements as is disclosed in U.S. Pat. No. 3,109,687, Nov. 5, 1963.

The invention proceeds upon the principle of combining with a spring-biased handle assembly, which normally tends to spring the handle into extended position, a latching device which retains the handle in retracted or nested position upon the depression of the handle, and which upon a slight depressing movement of the handle serves to automatically release the handle for springing to its extended position. The automatic operation of the latching mechanism is effected by a compact camming cylinder containing fixed upper and lower camming discs provided with opposed circumferential camming surfaces and seats, between which is moved a part of the latching mechanism, which serves to convert the rectilinear movements of the handle and said part of the latching mechanism into incremental rotary movements of the latter, to position one or more radial lugs at the upper end of the latching mechanism relative to a suitably apertured flange, which selectively permits or restrains the movement of the handle.

Other objects and purposes will appear from the detailed description of the invention following hereinafter, taken in conjunction with the accompanying drawings, wherein:

FIG. 1 is a front elevation, partly in section, showing the handle in retracted or storing position in solid lines, and in operative or extended position in dotted lines;

FIG. 2 is an enlarged vertical sectional view of the latching device shown at the central portion of FIG. 1;

FIG. 3 is a vertical sectional view along line 3-3 of FIG. 2;

FIG. 4 is a horizontal sectional view along line 4-4 of FIG. 2;

FIG. 5 is a horizontal sectional view along line 5-5 of FIG. 2, showing the device in latched position;

FIG. 6 is a sectional view similar to FIG. 5, showing the latching device in open or released position;

FIG. 7 is a developed view of the upper and lower camming discs within the camming cylinder cooperating with the advancing arm at the inner end of the rotary shaft of the latching device for converting the rectilinear movements thereof to incremental rotary movements; and

FIG. 8 is a front elevation, partly in section, similar to FIG. 1, showing a modified form of handle with spring-biasing

means therefor, and separate latching devices on each end thereof.

In the drawings is shown a case or container C which may be an item of luggage or any other portable receptacle for housing specialty items such as radio and television receivers, typewriters, record players, etc., and to which is connected a handle H capable of assuming a nested or inoperative position within a handle frame 1 forming part of the frame 2 of the portable case, or which may be extended from the frame to make possible the gripping of the handle for convenient transport thereof.

The main part of the handle 10 is provided with legs 11, 11' extending downwardly from the opposite ends of the handle 10 for accommodation within the receptacles 3, 3' at the opposite ends of the mounting frame for the handle.

A circular bore 12, 12' is provided in each of the legs 11, 11', respectively, for the accommodation of coil springs 15, 15' connected between retaining lugs 13, 13' at the base of the receptacles 3, 3' and lugs 14, 14' within the bores of the handle, respectively. As indicated by the arrows in FIG. 1, the springs 15, 15' serve to bias the handle H into its outwardly extending position indicated in dotted lines and are adapted to be compressed by a downward movement of the handle when the upper level of the handle 10 is substantially coincident with the outer surface of the case C, as indicated in solid lines in FIG. 1.

A latching mechanism is provided at the central portion of the handle and mounting frame therefor for the purpose of retaining the handle in its nested position against the force of the biasing springs 15, 15', which is released for extension by these springs upon a limited downward movement of the handle which is made possible by the clearance between the lower ends 17, 17' of the legs 11, 11' and the bottom of the receptacles 3, 3' of the mounting frame. This latching mechanism consists of a compact camming cylinder 20 affixed to the mounting frame 1 from which protrudes a rotary shaft provided with stop lugs at the upper end thereof which lugs are designed to cooperate with a retaining device 50 constituting part of the handle, as described more fully below.

The camming cylinder 20 may be affixed to the frame 1 by the protrusion of mounting flanges 21 through openings in the mounting frame which are bent transversely, as shown in FIGS. 2 and 4, to affix the cylinder to the mounting frame 1 on the interior of the portable case. An annular camming disc 22 is fixedly mounted at the upper end of the cylinder adjacent to the frame 1 by the provision of diametrically opposed pins or projections 23 seated within corresponding openings 23' at the upper end of cylinder 20. A second annular camming disc 25 is affixed to the lower end of the cylinder by the provision of downwardly extending studs 27 forming part of the annular camming disc 25 which fit within corresponding openings at the base of the cylinder and which is additionally centered by means of a central stud 26 fitting within a central opening at the bottom of cylinder 20.

A rotary shaft 40, formed with enlarged radial arms 41, 41' at the lower end thereof and with stop lugs 42 at the upper end thereof, is adapted to extend through the central opening 28 of the annular disc 22 and through an opening 6 in the frame 1 for cooperation with the latching flange forming part of member 50 in the lower part of the handle H. A coiled spring 32 with its lower end seated within the central recess 31 of camming disc 25 and its upper end within the central recess between radial arms 41, 41' serves to bias the latter upwardly into yielding contact with camming disc 22.

The radial arms 41 are rounded along the upper and lower edges thereof, as clearly shown in FIG. 2 and these top and bottom edges are adapted to move rectilinearly between the camming discs 22 and 25 in response to rectilinear movements of the shaft 40 as the same experiences the to-and-fro movements indicated by the vertical arrows in FIGS. 2 and 3, as the handle moves inwardly and outwardly. These rectilinear movements are, in turn, converted into rotary movements of shaft 40, as described below.

The retaining device 50, shown in FIG. 1, may be seated in handle H, or molded as an integral part of the latter if the handle is formed of plastic material. This device may be of cylindrical formation with the bottom thereof shaped as an annulus of four quadrants with the central opening 51 for the passage of the rotary shaft 40 into the interior of chamber 52. Two of the quadrants are formed as diametrically opposed flanges 52, 52' while the alternating quadrants 53, 53' merge with the central opening 51 and are of enlarged diameter so that when the stop lugs 42 are coincident with the quadrants 53, 53' the handle 10 is free to move upwardly by the action of the biasing springs 15, 15'. On the other hand, when the rotary shaft is turned 90° to bring the stop lugs 42 behind the flanges 52, 52', the handle is latched, and is incapable of outward movement despite the force exerted by the biasing springs 15, 15'.

FIG. 7 illustrates a developed view of the circumferential edges of the upper and lower camming discs 22 and 25, respectively, and the interaction of the radial arms 41, 41' therewith, which convert the to-and-fro movements of the handle to incremental rotary movements of the rotary shaft to bring the locking lugs 42 into latching or released positions with respect to alternating quadrants at the bottom of the retaining device 50.

The camming disc 22 is provided with a plurality of seats 22a, 22b, 22c and 22d which are circumferentially displaced 90° from each other, and also with alternating camming surfaces 22m, 22n, 22o and 22p. Likewise, the camming disc 25 is provided with seats 25a, 25b, 25c and 25d which are displaced 90° from each other as well as from the seats in the upper camming disc 22, but which are in line with the camming surfaces of the upper camming disc as shown in FIG. 7. Thus, for example, when the handle H is in extended position, and the locking lugs 42 are in alignment with the quadrants of enlarged diameter 53, 53', as indicated in FIG. 6, the handle is in raised position. When it is desired to move the handle to its nested or inoperative position, the same is pressed down and when the retaining device 50 arrives in the field of operation of the rotary or pivot shaft 40, the latter is moved downwardly from position A (FIG. 7), to bring the advancing arms 41, 41' into action against camming surface 25m, which, by virtue of the inclination as well as the curved contour of the camming edge, as shown in FIGS. 2 to 4, effects a partial rotation of the rotary shaft of approximately 62°. This movement is arrested when the bottom edges 17, 17' of the legs 11 of the handle come into abutment with the bottom of the receptacles 3, 3', respectively. However, the extension of spring 32 seated within the center of the lower camming disc 25 forces the radial arms upwardly into the path of the camming surface 22m of the upper annular disc to impart a supplemental rotation to the rotary shaft 40 amounting to approximately 28°, to complete the seating of the locking lugs 42 behind quadrants 52, 52', as illustrated in FIG. 5. With this condition of the parts, the locking handle remains in retracted or nested position until such time as it is desired to release it.

To effect the release of the handle, which is now in locked position, and in which the radial arms 41, 41' are now at position B, the handle is depressed from the position shown in FIG. 1 until the bottom edges 17, 17' strike the bottom of the receptacle which causes a movement of the rotary shaft, of approximately 62°, by the interaction of the radial arms against camming edges 25n, which ultimately is seated in seat 25b and which is moved upwardly by the action of spring 32 to cause the upper edge of the radial arm to move along camming edge 22n of the annular camming disc 22 to impart a supplemental rotation thereto amounting to 28°, which ends in the seating of the radial arm at seat 22c, corresponding to position C which is indicated in FIG. 6, and which permits the handle 1 to be extended by the action of the biasing springs 15.

A repeated depression of the handle gives rise to a downward movement of the radial arms 41, 41' to effect a rotary movement of the rotary shaft by the interaction of the arms with camming edge 25o to impart a rotation of 62° to the shaft, which is followed by the rise of the radial arms and the

rotary movement thereof by the action thereof against camming edge 22o, to complete the seating of the radial arms at position D, to latch the handle in its locked position.

In a similar manner, the handle H may be released by the depression thereof to move the radial advancing arms from position D to position A which permits the handle to be moved into extended position. Thus, the successive rectilinear movements of the handle effect the latching thereof while in nested position, and this latching may be released by the depression of the handle for a limited extent indicated in dotted lines at the bottom of the receptacles 3, 3' (FIG. 1) to permit the release of the handle into extended position.

In FIG. 8 is shown a modified form of handle assembly which employs toggle springs 61 at each end of the handle in lieu of coil springs to actuate the handle into its extended position. Also, this embodiment makes use of two cylindrical housings, one at each end of the handle frame, wherefrom extend the rotary shafts 65 which cooperate with suitably apertured retaining flanges 67 which may be molded integrally with the handle 60 and which extend into the field of action of the rotary shafts 65. The openings 68 at the ends of the flanges 67 may be contoured similarly to those shown in FIGS. 5 and 6, or differently therefrom, to alternately permit the passage of the stop lugs at the top of the shafts 65, so that the handle may be extended to the position shown in dotted lines or alternatively to lock the handle against movement by the rotation of the stop lugs, for example, to the position shown in FIG. 8, when the lugs may extend transversely to a longitudinal slot in the plates or flanges 67.

We claim:

1. A readily extensible and retractable handle assembly for a portable case adapted to be set into its alternate positions by a movement in the same direction, comprising:

- a. a handle;
- b. means for connecting said handle to said case including spring-biasing means for normally urging said handle to an extended position spaced from said case to provide a convenient hand-hold therefor;
- c. latching means on said handle and case for the retention of the handle in proximity to said case in the inoperative retracted position of said handle, comprising a rotatable and reciprocable post provided with radial lugs at the upper and lower ends thereof;
- d. a receptor on said handle having a central opening for said post and a radial opening emanating from said central opening greater in size than the radial lug at the upper end of said post, whereby the alignment of said lug and said opening permit said spring-biasing means to force said handle to its extended position remote from the case, while the misalignment of said lug and opening blocks the movement of said handle to its extended position; and
- e. an annular camming assembly at the lower end of said post provided with a plurality of camming faces adapted to cooperate with the lug at the lower end of said reciprocable post to impart incremental rotary movements to the latter to successively bring the upper lug into alignment and misalignment with said radial opening in said receptor of said handle, in response to successive manual movements of said handle towards said case.

2. A device as set forth in claim 1, wherein said rotatable and reciprocable post is provided with a pair of diametrically opposed radial lugs at the upper and lower ends thereof, and said receptor on said handle is provided with a pair of diametrically opposed radial openings emanating from the central opening sufficiently large to permit the passage of said lugs therethrough, said radial openings alternating with diametrically opposed blocking segments therebetween for restraining the movement of said handle into extended position.

3. A device as set forth in claim 1, wherein said annular camming assembly comprises:

- a. a cylindrical housing on said case for containing the lower portion of said post;

- b. annular camming discs fixedly mounted at the opposite ends of said housing, each provided with alternating seats and camming edges therebetween facing each other, with the radial lug at the lower end of said post between said camming discs;
- c. spring means in said housing for biasing said last-mentioned lug in a direction towards said handle; and
- d. said camming edges being so contoured that said manual movement of said handle towards said case effects a rotation of said radial lug to bring the post with the radial lug at the upper end thereof into cooperative action with the receptor on the handle to effect the alternate blocking and release thereof.
4. A device as set forth in claim 3, wherein said camming edges on said camming discs are so contoured that the inward movement of said handle effects a partial rotation of said post which is followed by an additional incremental rotation of said post caused by the distention of said spring means and consequent rectilinear movement of said post in the reverse direction.
5. A device as set forth in claim 4, wherein said seats in the camming discs are displaced circumferentially at 90° intervals.
6. A readily extensible and retractable handle assembly for a portable case comprising:
- a. a handle;
- b. means for connecting said handle to said case including spring-biasing means for normally urging said handle to an extended position spaced from said case to provide a convenient hand-hold therefor;
- c. latching means on said handle for the retention thereof in proximity to said case in the inoperative retracted position of said handle, having an opening with a retaining flange adjacent thereto;
- d. means for operating said latching means comprising a rotary member with an abutment thereon adapted to effectuate said latching means by interposing said abutment in the path of said retaining flange in response to the inward movement of said handle from its extended position to its retracted position proximate to the case, and to release said latching means by moving said abutment from the path of said retaining flange in response to another limited inward movement of said handle in the same direction, to permit the extension of said handle from the case by the operation of said spring-biasing means;
- e. said last-mentioned operating means comprising a cylin-

- drical housing on said case for containing the inner portion of said rotary member;
- f. annular camming discs fixedly mounted at the opposite ends of said housing each provided with alternating seats and camming edges therebetween facing each other with said seats in said camming discs displaced circumferentially at 90° intervals;
- g. a radial advancing arm at the inner end of said rotary member between said camming discs
- h. spring means in said housing for biasing said advancing arm in a direction towards said handle;
- i. said camming edges on said camming discs being so contoured that the inward movement of said handle effects a partial rotation of said advancing arm which is followed by an additional incremental rotation of said arm caused by the distention of said spring and consequent rectilinear movement of said radial arm in the reverse direction, to bring the latter into position for blocking by said latching means; and
- j. said last-mentioned blocking effective at alternate 90° intervals.
7. A device as set forth in claim 6, wherein said latching means comprises a pair of stop lugs extending from the outer end of said rotary member at diametrically opposite points, and a flange on said handle in overlying relation to said member and provided with openings of alternating quadrants surrounding said rotary member, the radial dimension of two of said quadrants being sufficient to permit passage of said stop lugs while the alternate quadrants restrain the movement thereof, the positioning of said stop lugs at said quadrants being coincident with the positioning of said advancing arm within said circumferentially displaced seats.
8. A device as set forth in claim 7, wherein said latching means and cylindrical housing are mounted at approximately the midportion of the handle assembly.
9. A device as set forth in claim 7, wherein said latching means and cylindrical housing are mounted at each end of the handle assembly.
10. A device as set forth in claim 1, wherein said spring-biasing means comprises a coil spring seated within a recess at each end of said handle.
11. A device as set forth in claim 1, wherein said spring-biasing means comprises a toggle-joint leaf spring connected between each end of said handle and case.

50

55

60

65

70

75