

(30) Priorités(suite)/Priorities(continued): 2013/10/11 (US61/889,757)

(12) INTERNATIONAL APPLICATION PUBLISHED UNDER THE PATENT COOPERATION TREATY (PCT)

(19) World Intellectual Property
Organization
International Bureau(10) International Publication Number
WO 2014/151188 A1(43) International Publication Date
25 September 2014 (25.09.2014)

(51) International Patent Classification:

C01B 3/50 (2006.01) H01M 8/14 (2006.01)
H01M 8/06 (2006.01)

(21) International Application Number:

PCT/US2014/025180

(22) International Filing Date:

13 March 2014 (13.03.2014)

(25) Filing Language:

English

(26) Publication Language:

English

(30) Priority Data:

61/787,879	15 March 2013 (15.03.2013)	US
61/788,628	15 March 2013 (15.03.2013)	US
61/787,587	15 March 2013 (15.03.2013)	US
61/787,697	15 March 2013 (15.03.2013)	US
61/884,605	30 September 2013 (30.09.2013)	US
61/884,635	30 September 2013 (30.09.2013)	US
61/884,586	30 September 2013 (30.09.2013)	US
61/884,565	30 September 2013 (30.09.2013)	US
61/884,376	30 September 2013 (30.09.2013)	US
61/884,545	30 September 2013 (30.09.2013)	US
61/889,757	11 October 2013 (11.10.2013)	US

(71) Applicant: **EXXONMOBIL RESEARCH AND ENGINEERING COMPANY** [US/US]; 1545 Route 22 East, P.O. Box 900, Amundale, NJ 08801-0900 (US).

(72) Inventors: **BERLOWITZ, Paul, J.**; 4 Nicole Terrace, Glen Gardner, NJ 08826 (US). **BARCKHOLTZ, Timothy, Andrew**; 224 Johnson Road, Whitehouse Station, NJ 08889 (US). **HERSHKOWITZ, Frank, H.**; 509 Lyons Road, Basking Ridge, NJ 07920 (US).

(74) Agents: **SHANLEY, Matthew, T.** et al.; Exxonmobil Research and Engineering Company 1545 Route 22 East, P.O. Box 900, Amundale, NJ 08801-0900 (US).

(81) Designated States (unless otherwise indicated, for every kind of national protection available): AE, AG, AL, AM, AO, AT, AU, AZ, BA, BB, BG, BH, BN, BR, BW, BY, BZ, CA, CH, CL, CN, CO, CR, CU, CZ, DE, DK, DM, DO, DZ, EC, EE, EG, ES, FI, GB, GD, GE, GH, GM, GT, HN, HR, HU, ID, IL, IN, IR, IS, JP, KE, KG, KN, KP, KR, KZ, LA, LC, LK, LR, LS, LT, LU, LY, MA, MD, ME, MG, MK, MN, MW, MX, MY, MZ, NA, NG, NI, NO, NZ, OM, PA, PE, PG, PH, PL, PT, QA, RO, RS, RU, RW, SA, SC, SD, SE, SG, SK, SL, SM, ST, SV, SY, TH, TJ, TM, TN, TR, TT, TZ, UA, UG, US, UZ, VC, VN, ZA, ZM, ZW.

(84) Designated States (unless otherwise indicated, for every kind of regional protection available): ARIPO (BW, GH, GM, KE, LR, LS, MW, MZ, NA, RW, SD, SL, SZ, TZ, UG, ZM, ZW), Eurasian (AM, AZ, BY, KG, KZ, RU, TJ, TM), European (AL, AT, BE, BG, CH, CY, CZ, DE, DK, EE, ES, FI, FR, GB, GR, HR, HU, IE, IS, IT, LT, LU, LV,

[Continued on next page]

(54) Title: INTEGRATED POWER GENERATION AND CARBON CAPTURE USING FUEL CELLS

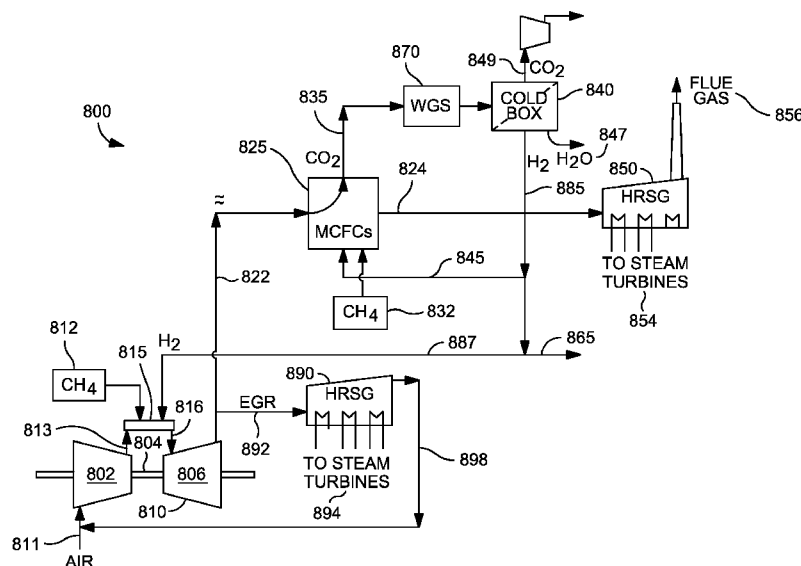

FIG. 8

(57) Abstract: Systems and methods are provided for capturing CO₂ from a combustion source using molten carbonate fuel cells (MCFCs). The fuel cells are operated to have a reduced anode fuel utilization. Optionally, at least a portion of the anode exhaust is recycled for use as a fuel for the combustion source. Optionally, a second portion of the anode exhaust is recycled for use as part of an anode input stream. This can allow for a reduction in the amount of fuel cell area required for separating CO₂ from the combustion source exhaust and/or modifications in how the fuel cells are operated.

WO 2014/151188 A1 

MC, MK, MT, NL, NO, PL, PT, RO, RS, SE, SI, SK,
SM, TR), OAPI (BF, BJ, CF, CG, CI, CM, GA, GN, GQ,
GW, KM, ML, MR, NE, SN, TD, TG).

— *before the expiration of the time limit for amending the
claims and to be republished in the event of receipt of
amendments (Rule 48.2(h))*

Published:

— *with international search report (Art. 21(3))*

INTEGRATED POWER GENERATION AND CARBON CAPTURE USING FUEL
CELLS

FIELD OF THE INVENTION

[0001] In various aspects, the invention is related to low emission power production with separation and/or capture of resulting emissions via integration of molten carbonate fuel cells with a combustion power source.

BACKGROUND OF THE INVENTION

[0002] Capture of gases emitted from power plants is an area of increasing interest. Power plants based on the combustion of fossil fuels (such as petroleum, natural gas, or coal) generate carbon dioxide as a by-product of the reaction. Historically this carbon dioxide has been released into the atmosphere after combustion. However, it is becoming increasingly desirable to identify ways to find alternative uses for the carbon dioxide generated during combustion.

[0003] One option for managing the carbon dioxide generated from a combustion reaction is to use a capture process to separate the CO₂ from the other gases in the combustion exhaust. An example of a traditional method for capturing carbon is passing the exhaust stream through an amine scrubber. While an amine scrubber can be effective for separating CO₂ from an exhaust stream, there are several disadvantages. In particular, energy is required to operate the amine scrubber and/or modify the temperature and pressure of the exhaust stream to be suitable for passing through an amine scrubber. The energy required for CO₂ separation reduces the overall efficiency of the power generation process.

[0004] In order to offset the power required for CO₂ capture, one option is to use a molten carbonate fuel cell to assist in CO₂ separation. The fuel cell reactions that cause transport of CO₂ from the cathode portion of the fuel cell to the anode portion of the fuel cell can also result in generation of electricity. However, conventional combinations of a combustion powered turbine or generator with fuel cells for carbon separation have resulted in a net reduction in power generation efficiency per unit of fuel consumed.

[0005] An article in the Journal of Fuel Cell Science and Technology (G. Manzoloni *et. al.*, *J. Fuel Cell Sci. and Tech.*, Vol. 9, Feb 2012) describes a power generation system that combines a combustion power generator with molten carbonate fuel cells.

Various arrangements of fuel cells and operating parameters are described. The combustion output from the combustion generator is used in part as the input for the cathode of the fuel cell. This input is supplemented with a recycled portion of the anode output after passing through the anode output through a cryogenic CO₂ separator.

[0006] One goal of the simulations in the Manzolini article is to use the MCFC to separate CO₂ from the power generator's exhaust. The simulation described in the Manzolini article establishes a maximum outlet temperature of 660° C and notes that the inlet temperature must be sufficiently cooler to account for the temperature increase across the fuel cell. The electrical efficiency (i.e. electricity generated/ fuel input) for the MCFC fuel cell in a base model case is 50%. The electrical efficiency in a test model case, which is optimized for CO₂ sequestration, is also 50%.

[0007] An article by Desideri *et al.* (*Intl. J. of Hydrogen Energy*, Vol. 37, 2012) describes a method for modeling the performance of a power generation system using a fuel cell for CO₂ separation. Recirculation of anode exhaust to the anode inlet and the cathode exhaust to the cathode inlet are used to improve the performance of the fuel cell. Based on the model and configuration shown in the article, increasing the CO₂ utilization within the fuel cell is shown as being desirable for improving separation of CO₂. The model parameters describe an MCFC electrical efficiency of 50.3%.

[0008] U.S. Patent No. 7,396,603 describes an integrated fossil fuel power plant and fuel cell system with CO₂ emissions abatement. At least a portion of the anode output is recycled to the anode input after removal of a portion of CO₂ from the anode output.

[0009] Molten carbonate fuel cells utilize hydrogen and/or other fuels to generate electricity. The hydrogen may be provided by reforming methane or other reformable fuels in a steam reformer that is upstream of the fuel cell or within the fuel cell. Reformable fuels can encompass hydrocarbonaceous materials that can be reacted with steam and/or oxygen at elevated temperature and/or pressure to produce a gaseous product that comprises hydrogen. In particular, reformable fuel can include, but is not limited to, alkanes, alkenes, alcohols, aromatics, and/or other carbonaceous and organic compounds that can be reformed to generate H₂ and carbon oxides (either CO or CO₂). Alternatively or additionally, fuel can be reformed in the anode cell in a molten carbonate fuel cell, which can be operated to create conditions that are suitable for

reforming fuels in the anode. Alternately or additionally, the reforming can occur both externally and internally to the fuel cell.

[0010] Traditionally, molten carbonate fuel cells are operated to maximize electricity production per unit of fuel input, which may be referred to as the fuel cell's electrical efficiency. This maximization can be based on the fuel cell alone or in conjunction with another power generation system. In order to achieve increased electrical production and to manage the heat generation, fuel utilization within a fuel cell is typically maintained at 70% to 75%.

[0011] U.S. Published Patent Application 2011/0111315 describes a system and process for operating fuel cell systems with substantial hydrogen content in the anode inlet stream. The technology in the '315 publication is concerned with providing enough fuel in the anode inlet so that sufficient fuel remains for the oxidation reaction as the fuel approaches the anode exit. To ensure adequate fuel, the '315 publication provides fuel with a high concentration of H₂. The H₂ not utilized in the oxidation reaction is recycled to the anode for use in the next pass. On a single pass basis, the H₂ utilization may range from 10% to 30%. The '315 reference does not describe significant reforming within the anode, instead relying primarily on external reforming.

[0012] U.S. Published Patent Application 2005/0123810 describes a system and method for co-production of hydrogen and electrical energy. The co-production system comprises a fuel cell and a separation unit, which is configured to receive the anode exhaust stream and separate hydrogen. A portion of the anode exhaust is also recycled to the anode inlet. The operating ranges given in the '810 publication appear to be based on a solid oxide fuel cell. Molten carbonate fuel cells are described as an alternative.

[0013] U.S. Published Patent Application 2003/0008183 describes a system and method for co-production of hydrogen and electrical power. A fuel cell is mentioned as a general type of chemical converter for converting a hydrocarbon-type fuel to hydrogen. The fuel cell system also includes an external reformer and a high temperature fuel cell. An embodiment of the fuel cell system is described that has an electrical efficiency of about 45% and a chemical production rate of about 25% resulting in a system coproduction efficiency of about 70%. The '183 publication does

not appear to describe the electrical efficiency of the fuel cell in isolation from the system.

[0014] U.S. Patent 5,084,362 describes a system for integrating a fuel cell with a gasification system so that coal gas can be used as a fuel source for the anode of the fuel cell. Hydrogen generated by the fuel cell is used as an input for a gasifier that is used to generate methane from a coal gas (or other coal) input. The methane from the gasifier is then used as at least part of the input fuel to the fuel cell. Thus, at least a portion of the hydrogen generated by the fuel cell is indirectly recycled to the fuel cell anode inlet in the form of the methane generated by the gasifier.

SUMMARY OF THE INVENTION

[0015] In one aspect, a method for capturing carbon dioxide from a combustion source is provided. The method can introducing one or more fuel streams and an O₂-containing stream into a combustion zone; performing a combustion reaction in the combustion zone to generate a combustion exhaust, the combustion exhaust comprising CO₂; processing at least a first portion of the combustion exhaust with a fuel cell array of one or more molten carbonate fuel cells to form a cathode exhaust stream from at least one cathode outlet of the fuel cell array, the one or more fuel cells each having an anode and a cathode, the molten carbonate fuel cells being operatively connected to the combustion exhaust through one or more cathode inlets in the fuel cell array; reacting carbonate from the one or more fuel cell cathodes with hydrogen within the one or more fuel cell anodes to produce electricity, an anode exhaust stream from at least one anode outlet of the fuel cell array comprising CO₂ and H₂; separating CO₂ from the anode exhaust stream in one or more separation stages to form a CO₂-depleted anode exhaust stream; passing at least a first portion of the CO₂-depleted anode exhaust stream to the combustion zone; and recycling at least a second portion of the CO₂-depleted anode exhaust stream to one or more of the fuel cell anodes.

[0016] This application is related to 21 other PCT applications, filed on even date herewith: WO 2014/151182; WO 2014/151184; WO 2014/151187; WO 2014/151189; WO 2014/151192; WO 2014/151194; WO 2014/151199; WO 2014/151191; WO 2014/151193; WO 2014/151196; WO 2014/151203; WO 2014/151210; WO 2014/151214; WO 2014/151216; WO 2014/151219; WO 2014/151225;

WO 2014/151207; WO 2014/151212; WO 2014/151215; WO 2014/151218; and WO 2014/151224.

BRIEF DESCRIPTION OF THE DRAWINGS

[0017] FIG. 1 schematically shows an example of a combined cycle system for generating electricity based on combustion of a carbon-based fuel.

[0018] FIG. 2 schematically shows an example of the operation of a molten carbonate fuel cell.

[0019] FIG. 3 shows an example of the relation between anode fuel utilization and voltage for a molten carbonate fuel cell.

[0020] FIG. 4 schematically shows an example of a configuration for an anode recycle loop.

[0021] FIG. 5 shows an example of the relation between CO₂ utilization, voltage, and power for a molten carbonate fuel cell.

[0022] FIG. 6 schematically shows an example of a configuration for molten carbonate fuel cells and associated reforming and separation stages.

[0023] FIG. 7 schematically shows another example of a configuration for molten carbonate fuel cells and associated reforming and separation stages.

[0024] FIG. 8 schematically shows an example of a combined cycle system for generating electricity based on combustion of a carbon-based fuel.

[0025] FIG. 9 schematically shows an example of a combined cycle system for generating electricity based on combustion of a carbon-based fuel.

[0026] FIGS. 10-15 show results from simulations of various configurations of a power generation system including a combustion-powered turbine and a molten carbonate fuel cell for carbon dioxide separation.

[0027] FIGS. 16 and 17 show examples of CH₄ conversion at different fuel cell operating voltages V_A .

DETAILED DESCRIPTION OF THE EMBODIMENTS

[0028] In various aspects, systems and methods are provided for capturing CO₂ from a combustion source using molten carbonate fuel cells (MCFCs). The systems and methods can address one or more problems related to carbon capture from combustion exhaust stream and/or performing carbon capture using molten carbonate fuel cells.

[0029] One difficulty with conventional uses of carbon capture technology in conjunction with a combustion-based power source for power generation, such as use of molten carbonate fuel cells as part of a carbon capture scheme, is that the overall efficiency of the power generation system is reduced. Although molten carbonate fuel cells can generate electrical power, so that the net power generated by a system is increased, conventional combinations of fuel cells with combustion-powered generators result in net lower power efficiency for the power plant as a whole. In other words, the electrical power produced (watts) per unit of fuel input (lower heating value of the fuel, kJ) is reduced. This can be due in part to additional power or heating requirements for operating the additional carbon capture components. This can also be due in part to a lower efficiency of power generation for conventionally operated fuel cells in comparison with a system such as a combustion-powered turbine.

[0030] In some aspects, the overall efficiency of a carbon capture system that includes molten carbonate fuel cells can be improved by operating the fuel cells at lower anode fuel utilization values. Conventionally, molten carbonate fuel cells can be operated at a fuel utilization that balances the heat needed to operate the fuel cell with the fuel consumed within the cell. The fuel utilization in conventional fuel cells can typically be made as high as possible while maintaining this heat balance. By contrast, it has been determined that, for various types of power system configurations, reducing the anode fuel utilization of fuel cell array can allow for improved power generation efficiency for the overall system.

[0031] Another difficulty with using molten carbonate fuel cells for separation of CO₂ from an exhaust stream can include the large area of fuel cells typically required for handling the exhaust from a commercial scale turbine or other power/heat generator. Accommodating a commercial scale exhaust flow using molten carbonate fuel cells can typically involve using a plurality of fuel cells, rather than constructing a single fuel cell of sufficient area. In order to deliver the exhaust stream to this plurality of fuel cells, additional connections can be required in order to divide the exhaust between the various fuel cells. Thus, reducing the fuel cell area required to capture a desired amount of carbon dioxide can provide a corresponding decrease in the number and/or complexity of flow connections required.

[0032] In some aspects of the invention, the area of fuel cells required for processing a CO₂-containing exhaust stream can be reduced or minimized by recycling at least a portion of the anode exhaust stream back to the anode inlet. Additionally or alternately, the fuel cells can be operated at lower fuel utilization. An exhaust stream can be passed into the cathode(s) of molten carbonate fuel cells. During operation of the fuel cell, the anode exhaust can be passed through one or more separation stages. This can include separation stages for removal of H₂O and/or CO₂. At least a portion of the remaining anode exhaust can then be recycled to the anode input. In one preferred embodiment, any recycle of the anode exhaust directly to the cathode can be avoided. By recycling at least some portion the anode exhaust to the anode inlet, at least some of the fuel not used on the first pass through the anode can be utilized in a subsequent pass.

[0033] In addition to or as an alternative to recycling the anode exhaust to the anode inlet, at least a portion of the hydrogen in the anode exhaust can be recycled to the

combustion zone for a turbine or other combustion-powered generator/heat source. It is noted that any hydrogen generated via reforming as part of the anode loop can represent a fuel where the CO₂ has already been “captured” by transfer to the anode loop. This can reduce the amount of CO₂ needing to be transferred from the cathode side to the anode side of the fuel cell, and therefore can lead to a reduced fuel cell area.

[0034] An additional or alternative feature that can contribute to a reduced fuel cell area can be reducing and/or minimizing the amount of energy required for processes not directly involved in power generation. For example, the anode reaction in a molten carbonate fuel cell can combine H₂ with CO₃²⁻ ions transported across the electrolyte between cathode and anode to form H₂O and CO₂. Although the anode reaction environment can facilitate some reforming of a fuel such as CH₄ to form H₂, some H₂ can advantageously be present in a fuel in order to maintain desirable reaction rates in the anode. As a result, prior to entering the anode itself, fuels (such as natural gas/methane) are conventionally at least partially reformed prior to entering the anode. The reforming stage prior to the anode for a fuel cell can require additional heat in order to maintain a suitable temperature for reforming.

[0035] In some aspects of the invention, recycling at least a portion of the anode exhaust to the anode inlet can allow for a reduced amount of reforming and/or elimination of the reforming stage prior to the anode inlet. Instead of reforming a fuel stream prior to entering the anode, the recycled anode exhaust can provide sufficient hydrogen for the fuel input to the anode. This can allow the input stream for the anode to be passed into the anode without passing through a separate pre-reforming stage. Operating the anode at a reduced level of hydrogen fuel utilization can further facilitate reducing and/or eliminating the pre-reforming stage by providing an anode exhaust with increased hydrogen content. Increasing the hydrogen content can allow a portion of the anode exhaust to also be used as an input to the turbine combustion zone, while still having sufficient hydrogen in the feed to the anode inlet so that pre-reforming can be reduced and/or eliminated.

[0036] Another challenge with using molten carbonate fuel cells can be due to the relatively low CO₂ content of the exhaust of properly operated gas turbine. For example, a gas turbine powered by a low CO₂ content natural gas fuel source can generate an exhaust, for example, with a CO₂ of about 4 vol%. If some type of exhaust

gas recycle is used, this value can be raised, for example, to about 6 vol%. By contrast, a typical desired CO₂ content for the input to the cathode of a molten carbonate fuel cell can be about 10% or more. In some aspects of the invention, systems and methods are provided herein to allow for increased CO₂ content in the exhaust gas while still efficiently operating the gas turbine or other combustion powered generator. In some aspects of the invention, systems and methods are provided for improving and/or optimizing the efficiency of carbon capture by the fuel cell when operated with a cathode exhaust having a low CO₂ content.

[0037] Still another challenge can include reducing or mitigating the loss of efficiency in power generation caused by carbon capture. As noted above, conventional methods of carbon capture can result in a loss of net efficiency in power generation per unit of fuel consumed. In some aspects of the invention, systems and methods are provided for improving the overall power generation efficiency. Additionally or alternately, in some aspects of the invention, methods are provided for separating CO₂ in a manner to reduce and/or minimize the energy required for generation of a commercially valuable CO₂ stream.

[0038] In most aspects of the invention, one or more of the above advantages can be achieved, at least in part, by using molten carbonate fuel cells in combination with a combined cycle power generation system, such as a natural gas fired combined cycle plant, where the flue gas and/or heat from combustion reaction(s) can also be used to power a steam turbine. More generally, the molten carbonate fuel cells can be used in conjunction with various types of power or heat generation systems, such as boilers, combustors, catalytic oxidizers, and/or other types of combustion powered generators. In some aspects of the invention, at least a portion of the anode exhaust from the MCFCs can be (after separation of CO₂) recycled to the input flow for the MCFC anode(s). Additionally or alternately, a portion of the anode exhaust from the MCFCs can be recycled to the input flow for the combustion reaction for power generation. In one embodiment, a first portion of the anode exhaust from the MCFCs (after separation of CO₂) can be recycled to the input flow for the MCFC anode(s), and a second portion of the anode exhaust from the MCFCs can be recycled to the input flow for the combustion reaction for power generation. In aspects where the MCFCs can be operated with remaining (unreacted) H₂ in the anode exhaust, recycling a portion of the

H₂ from the anode exhaust to the anode input can reduce the fuel needed for operating the MCFCs. The portion of H₂ delivered to the combustion reaction can advantageously modify and/or improve reaction conditions for the combustion reaction, leading to more efficient power generation. A water-gas shift reaction zone after the anode exhaust can optionally be used to further increase the amount of H₂ present in the anode exhaust while also allowing conversion of CO into more easily separable CO₂.

[0039] In various aspects of the invention, an improved method for capturing CO₂ from a combustion source using a molten carbonate fuel cell can be provided. This can include, for example, systems and methods for power generation using turbines (or other power or heat generation methods based on combustion, such as boilers, combustors, and/or catalytic oxidizers) while reducing and/or mitigating emissions during power generation. This can optionally be achieved, at least in part, by using a combined cycle power generation system, where the flue gas and/or heat from combustion reaction(s) can also be used to power a steam turbine. This can additionally or alternately be achieved, at least in part, by using one or more molten carbonate fuel cells (MCFCs) as both a carbon capture device as well as an additional source of electrical power. In some aspects of the invention, the MCFCs can be operated under low fuel utilization conditions that can allow for improved carbon capture in the fuel cell while also reducing and/or minimizing the amount of fuel lost or wasted. Additionally or alternately, the MCFCs can be operated to reduce and/or minimize the total number and/or volume of MCFCs required to reduce the CO₂ content of a combustion flue gas stream to a desired level, for example, 1.5 vol% or less or 1.0 vol% or less. In such aspects, for the cathode output from the final cathode(s) in an array sequence (typically at least including a series arrangement, or else the final cathode(s) and the initial cathode(s) would be the same), the output composition can include about 2.0 vol% or less of CO₂ (e.g., about 1.5 vol% or less or about 1.2 vol% or less) and/or at least about 1.0 vol% of CO₂, such as at least about 1.2 vol% or at least about 1.5 vol%. Such aspects can be enabled, at least in part, by recycling the exhaust from the anode back to the inlet of the anode, with removal of at least a portion of the CO₂ in the anode exhaust prior to returning the anode exhaust to the anode inlet. Such removal of CO₂ from the anode exhaust can be achieved, for example, using a cryogenic CO₂ separator. In some optional aspects of the invention,

the recycle of anode exhaust to the anode inlet can be performed so that no pathway is provided for the anode exhaust to be recycled directly to the cathode inlet. By avoiding recycle of anode exhaust directly to the cathode inlet, any CO₂ transported to the anode recycle loop via the MCFCs can remain in the anode recycle loop until the CO₂ is separated out from the other gases in the loop.

[0040] Molten carbonate fuel cells are conventionally used in a standalone mode to generate electricity. In a standalone mode, an input stream of fuel, such as methane, can be passed into the anode side of a molten carbonate fuel cell. The methane can be reformed (either externally or internally) to form H₂ and other gases. The H₂ can then be reacted with carbonate ions that have crossed the electrolyte from the cathode in the fuel cell to form CO₂ and H₂O. For the reactions in the anode of the fuel cell, the rate of fuel utilization is typically about 70% or 75%, or even higher. In a conventional configuration, the remaining fuel in the anode exhaust can be oxidized (burned) to generate heat for maintaining the temperature of the fuel cell and/or external reformer, in view of the endothermic nature of the reforming reaction. Air and/or another oxygen source can be added during this oxidation to allow for more complete combustion. The anode exhaust (after oxidation) can then be passed into the cathode. In this manner, a single fuel stream entering the anode can be used to provide all of the energy and nearly all of the reactants for both anode and cathode. This configuration can also allow all of the fuel entering the anode to be consumed while only requiring ~70% or ~75% or slightly more fuel utilization in the anode.

[0041] In the above standalone method, which can be typical of conventional systems, the goal of operating a molten carbonate fuel cell can be generally to efficiently generate electric power based on an input fuel stream. By contrast, a molten carbonate fuel cell integrated with a combustion powered turbine, engine, or other generator can be used to provide additional utility. Although high-efficiency power generation by the fuel cell is still desirable, the fuel cell can be operated, for instance, to improve and/or maximize the amount of CO₂ captured from an exhaust stream for a given volume of fuel cells. This can allow for improved CO₂ capture while still generating power from the fuel cell. Additionally, in some aspects of the invention, the exhaust from the anode(s) of the fuel cell(s) can still contain excess hydrogen. This

excess hydrogen can advantageously be used as a fuel for the combustion reaction for the turbine, thus allowing for improved efficiency for the turbine.

[0042] FIG. 1 provides a schematic overview for the concept of some aspects of the invention. FIG. 1 is provided to aid in understanding of the general concept, so additional feeds, processes, and or configurations can be incorporated into FIG. 1 without departing from the spirit of the overall concept. In the overview example shown in FIG. 1, a natural gas turbine 110 (or another combustion-powered turbine) can be used to generate electric power based on combustion of a fuel 112. For the natural gas turbine 110 shown in FIG. 1, this can include compressing an air stream or other gas phase stream 111 to form a compressed gas stream 113. The compressed gas stream 113 can then be introduced into a combustion zone 115 along with fuel 112. Additionally, a stream 185, including a portion of the fuel (hydrogen) present in the exhaust from anode 130, can also be introduced into the combustion zone 115. This additional hydrogen can allow the combustion reaction to be operated under enhanced conditions. The resulting hot flue or exhaust gas 117 can then be passed into the expander portion of turbine 110 to generate electrical power.

[0043] After expansion (and optional clean up and/or other processing steps), the expanded flue gas can be passed into the cathode portion 120 of a molten carbonate fuel cell. The flue gas can include sufficient oxygen for the reaction at the cathode, or additional oxygen can be provided if necessary. To facilitate the fuel cell reaction, fuel 132 can be passed into the anode portion 130 of the fuel cell, along with at least a portion of the anode exhaust. Prior to being recycled, the anode exhaust can be passed through several additional processes. One additional process can include or be a water-gas shift reaction process. The water gas-shift reaction can be used to react H₂O and CO present in the anode exhaust to form additional H₂ and CO₂. This can allow for improved removal of carbon from the anode exhaust, as CO₂ can typically be more readily separated from the anode exhaust, as compared to CO. The output 175 from the (optional) water-gas shift process can then be passed through a carbon dioxide separation system 140, such as a cryogenic carbon dioxide separator. This can remove at least a portion of CO₂ 147 from the anode exhaust, typically as well as a portion of the water 149 also. After removal of at least a portion of the CO₂ and water, the recycled anode exhaust can still contain some CO₂ and

water, as well as unreacted fuel in the form of H₂ and/or possibly a hydrocarbon such as methane. In certain embodiments of the invention, a portion 145 of the output from the CO₂ separation stage(s) can be recycled for use as an input stream to anode 130, while a second portion can be used as input to the combustion reaction 115. Fuel 132 can represent a hydrogen-containing stream and/or a stream containing methane and/or another hydrocarbon that can be reformed (internally or externally) to form H₂.

[0044] The exhaust from the cathode portion 120 of the fuel cell can then be passed into a heat recovery zone 150 so that heat from the cathode exhaust can be recovered, *e.g.*, to power a steam generator 160. After recovering heat, the cathode exhaust can exit the system as an exhaust stream 156. The exhaust stream 156 can exit to the environment, or optional additional clean-up processes can be used, such as performing additional CO₂ capture on stream 156, for example, using an amine scrubber.

[0045] One way of characterizing the operation of a fuel cell can be to characterize the “utilization” of various inputs received by the fuel cell. For example, one common method for characterizing the operation of a fuel cell can be to specify the (anode) fuel utilization for the fuel cell.

[0046] In addition to fuel utilization, the utilization for other reactants in the fuel cell can be characterized. For example, the operation of a fuel cell can additionally or alternately be characterized with regard to “CO₂ utilization” and/or “oxidant” utilization. The values for CO₂ utilization and/or oxidant utilization can be specified in a similar manner. For CO₂ utilization, the simplified calculation of $(\text{CO}_2\text{-rate-in} - \text{CO}_2\text{-rate-out}) / \text{CO}_2\text{-rate-in}$ can be used if CO₂ is the only fuel component present in the input stream or flow to the cathode, with the only reaction thus being the formation of CO₃²⁻. Similarly, for oxidant utilization, the simplified version can be used if O₂ is the only oxidant present in the input stream or flow to the cathode, with the only reaction thus being the formation of CO₃²⁻.

[0047] Another reason for using a plurality of fuel cells can be to allow for efficient fuel cell operation while reducing the CO₂ content of the combustion exhaust to a desired level. Rather than operating a fuel cell to have a high (or optimal) rate of CO₂ utilization, two (or more) fuel cells can be operated at lower fuel utilization rate(s) while reducing the combustion to a desired level.

[0048] During conventional operation of a fuel cell, such as standalone operation, the goal of operating the fuel cell can be to generate electrical power while efficiently using the “fuel” provided to the cell. The “fuel” can correspond to either hydrogen (H_2), a gas stream comprising hydrogen, and/or a gas stream comprising a substance that can be reformed to provide hydrogen (such as methane, another alkane or hydrocarbon, and/or one or more other types of compounds containing carbon and hydrogen that, upon reaction, can provide hydrogen). These reforming reactions are typically endothermic and thus usually consume some heat energy in the production of hydrogen. Carbon sources that can provide CO directly and/or upon reaction can also be utilized, as typically the water gas shift reaction ($CO + H_2O = H_2 + CO_2$) can occur in the presence of the fuel cell anode catalyst surface. This can allow for production of hydrogen from a CO source. For such conventional operation, one potential goal of operating the fuel cell can be to consume all of the fuel provided to the cell, while maintaining a desirable output voltage for the fuel cell, which can be traditionally accomplished by operating the fuel cell anode at a fuel utilization of about 70% to about 75%, followed by combusting (such as burning) the remaining fuel to generate heat to maintain the temperature of the fuel cell. The fuel utilization can be measured in terms of the total enthalpy of the fuel used in the fuel cell reactions divided by the enthalpy of the fuel entering the fuel cell.

[0049] In a molten carbonate fuel cell, the transport of carbonate ions across the electrolyte in the fuel cell can provide a method for transporting CO_2 from a first flow path to a second flow path, where the transport method can allow transport from a lower concentration (the cathode) to a higher concentration (the anode), which can thus facilitate capture of CO_2 . Part of the selectivity of the fuel cell for CO_2 separation can be based on the electrochemical reactions allowing the cell to generate electrical power. For nonreactive species (such as N_2) that effectively do not participate in the electrochemical reactions within the fuel cell, there can be an insignificant amount of reaction and transport from cathode to anode. By contrast, the potential (voltage) difference between the cathode and anode can provide a strong driving force for transport of carbonate ions across the fuel cell. As a result, the transport of carbonate ions in the molten carbonate fuel cell can allow CO_2 to be transported from the cathode (lower CO_2 concentration) to the anode (higher CO_2 concentration) with relatively high

selectivity. However, a challenge in using molten carbonate fuel cells for carbon dioxide removal can be that the fuel cells have limited ability to remove carbon dioxide from relatively dilute cathode feeds. The voltage and/or power generated by a carbonate fuel cell can start to drop rapidly as the CO₂ concentration falls below about 2.0 vol%. As the CO₂ concentration drops further, e.g., to below about 1.0 vol%, at some point the voltage across the fuel cell can become low enough that little or no further transport of carbonate may occur and the fuel cell ceases to function. Thus, at least some CO₂ is likely to be present in the exhaust gas from the cathode stage of a fuel cell under commercially viable operating conditions.

[0050] The amount of carbon dioxide delivered to the fuel cell cathode(s) can be determined based on the CO₂ content of a source for the cathode inlet. One example of a suitable CO₂-containing stream for use as a cathode input flow can be an output or exhaust flow from a combustion source. Examples of combustion sources include, but are not limited to, sources based on combustion of natural gas, combustion of coal, and/or combustion of other hydrocarbon-type fuels (including biologically derived fuels). Additional or alternate sources can include other types of boilers, fired heaters, furnaces, and/or other types of devices that burn carbon-containing fuels in order to heat another substance (such as water or air). To a first approximation, the CO₂ content of the output flow from a combustion source can be a minor portion of the flow. Even for a higher CO₂ content exhaust flow, such as the output from a coal-fired combustion source, the CO₂ content from most commercial coal-fired power plants can be about 15 vol% or less. More generally, the CO₂ content of an output or exhaust flow from a combustion source can be at least about 1.5 vol%, or at least about 1.6 vol%, or at least about 1.7 vol%, or at least about 1.8 vol% , or at least about 1.9 vol%, or at least greater 2 vol%, or at least about 4 vol%, or at least about 5 vol%, or at least about 6 vol%, or at least about 8 vol%. Additionally or alternately, the CO₂ content of an output or exhaust flow from a combustion source can be about 20 vol% or less, such as about 15 vol% or less, or about 12 vol% or less, or about 10 vol % or less, or about 9 vol % or less, or about 8 vol % or less, or about 7 vol% or less, or about 6.5 vol% or less, or about 6 vol% or less, or about 5.5 vol% or less, or about 5 vol% or less, or about 4.5 vol% or less. The concentrations given above are on a dry basis. It is noted that the lower CO₂ content values can be present in the exhaust from some natural gas or methane

combustion sources, such as generators that are part of a power generation system that may or may not include an exhaust gas recycle loop.

Operation of Anode Portion and Anode Recycle Loop

[0051] In various aspects of the invention, molten carbonate fuel cells can be operated under conditions that allow for lower fuel utilization in the anode portion of the fuel cell. This can be in contrast to conventional operation for fuel cells, where the fuel utilization can be typically selected in order to allow a 70% or more of the fuel delivered to the fuel cell to be consumed as part of operation of the fuel cell. In conventional operation, almost all of the fuel can be typically either consumed within the anode of the fuel cell or burned to provide sensible heat for the feed streams to the fuel cell.

[0052] FIG. 3 shows an example of the relationship between fuel utilization and output power for a fuel cell operating under conventional (stand-alone) conditions. The diagram shown in FIG. 3 shows two limiting cases for operation of a fuel cell. One limiting case includes the limit of operating a fuel cell to consume an amount of fuel (such as H₂ or methane reformed into H₂) that approaches 100% of the fuel delivered to the fuel cell. From an efficiency standpoint, consumption of ~100% of the fuel delivered to a fuel cell would be desirable, so as not to waste fuel during operation of the fuel cell. However, there are two potential drawbacks with operating a fuel cell to consume more than about 80% of the fuel delivered to the cell. First, as the amount of fuel consumed approaches 100%, the voltage provided by the fuel cell can be sharply reduced. In order to consume an amount of fuel approaching 100%, the concentration of the fuel in the fuel cell (or at least near the anode) must almost by definition approach zero during at least part of the operation of the fuel cell. Operating the anode of the fuel cell with a fuel concentration approaching zero can result in a decreasingly low driving force for transporting carbonate across the electrolyte of the fuel cell. This can cause a corresponding drop in voltage, with the voltage potentially also approaching zero in the true limiting case of consuming all fuel provided to the anode.

[0053] The second drawback is also related to relatively high fuel utilization values (greater than about 80%). As shown in FIG. 3, at fuel utilization values of about 75% or less, the voltage generated by the fuel cell has a roughly linear relationship with the fuel utilization. In FIG. 3, at about 75% fuel utilization, the voltage generated can be about

0.7 Volts. In FIG. 3, at fuel utilization values of about 80% or greater, the voltage versus utilization curve appears to take on an exponential or power type relationship. From a process stability standpoint, it can be preferable to operate a fuel cell in a portion of the voltage versus utilization curve where the relationship is linear.

[0054] In the other limiting case shown in FIG. 3, the voltage generated by a molten carbonate fuel cell shows a mild increase as the fuel utilization decreases. However, in conventional operation, operating a fuel cell at reduced utilization can pose various difficulties. For example, the total amount of fuel delivered to a conventionally operated fuel cell operated with lower fuel utilization may need to be reduced, so that whatever fuel remains in the anode exhaust/output stream can still provide the appropriate amount of heat (upon further combustion) for maintaining the fuel cell temperature. If the fuel utilization is reduced without adjusting the amount of fuel delivered to the fuel cell, the oxidation of the unused fuel may result in higher than desired temperatures for the fuel cell. Based at least on these limiting case considerations, conventional fuel cells are typically operated at a fuel utilization of about 70% to about 75%, so as to achieve heat balance with complete utilization of the fuel.

[0055] An alternative configuration can be to recycle at least a portion of the exhaust from a fuel cell anode to the input of a fuel cell anode. The output stream from an MCFC anode can include H₂O, CO₂, optionally CO, and optionally but typically unreacted fuel (such as H₂ or CH₄) as the primary output components. Instead of using this output stream as a fuel source to provide heat for a reforming reaction, one or more separations can be performed on the anode output stream in order to separate out the CO₂ from the components with potential fuel value, such as H₂ and/or CO. The components with fuel value can then be recycled to the input of an anode.

[0056] This type of configuration can provide one or more benefits. First, CO₂ can be separated out from the anode output, such as by using a cryogenic CO₂ separator. Several of the components of the anode output (H₂, CO, CH₄) are not easily condensable components, while CO₂ and H₂O can be separated individually as condensed phases. Depending on the embodiment, at least about 90 vol% of the CO₂ in the anode output can be separated out to form a relatively high purity CO₂ output stream. After separation, the remaining portion of the anode output can correspond

primarily to components with fuel value, as well as reduced amounts of CO₂ and/or H₂O. This portion of the anode output after separation can be recycled for use as part of the anode input, along with additional fuel. In this type of configuration, even though the fuel utilization in a single pass through the MCFC(s) may be low, the unused fuel can be advantageously recycled for another pass through the anode. As a result, the single-pass fuel utilization can be at a reduced level, while avoiding loss (exhaust) of unburned fuel to the environment.

[0057] Additionally or alternatively to recycling a portion of the anode exhaust to the anode input, another configuration option can be to use a portion of the anode exhaust as an input for a combustion reaction for a turbine or other combustion power source. The relative amounts of anode exhaust recycled to the anode input and/or as an input to the combustion zone can be any convenient or desirable amount. If the anode exhaust is recycled to only one of the anode input and the combustion zone, the amount of recycle can be any convenient amount, such as up to 100% of the portion of the anode exhaust remaining after any separation to remove CO₂ and/or H₂O. When a portion of the anode exhaust is recycled to both the anode input and the combustion zone, the total recycled amount by definition can be 100% or less of the remaining portion of anode exhaust. Otherwise, any convenient split of the anode exhaust can be used. In various embodiments of the invention, the amount of recycle to the anode input can be at least about 10% of the anode exhaust remaining after separations, for example at least about 25%, at least about 40%, at least about 50%, at least about 60%, at least about 75%, or at least about 90%. Additionally or alternately in those embodiments, the amount of recycle to the anode input can be about 90% or less of the anode exhaust remaining after separations, for example about 75% or less, about 60% or less, about 50% or less, about 40% or less, about 25% or less, or about 10% or less. Further additionally or alternately, in various embodiments of the invention, the amount of recycle to the combustion zone (turbine) can be at least about 10% of the anode exhaust remaining after separations, for example at least about 25%, at least about 40%, at least about 50%, at least about 60%, at least about 75%, or at least about 90%. Additionally or alternately in those embodiments, the amount of recycle to the combustion zone (turbine) can be about 90% or less of the anode exhaust remaining after separations, for

example about 75% or less, about 60% or less, about 50% or less, about 40% or less, about 25% or less, or about 10% or less.

[0058] Any H₂ present in the anode exhaust can represent a fuel that can be combusted without generating CO₂. Because at least some H₂ can be generated as part of the anode portion of the fuel cell(s), the CO₂ generated during reforming can be primarily removed by the CO₂ separation stage(s) in the anode portion of the system. As a result, use of H₂ from the anode exhaust as part of the fuel for the combustion reaction can allow for a situation where the CO₂ generated from “combustion” of the fuel can be created in the anode portion of the system, as opposed to having to transport the CO₂ across the membrane.

[0059] Recycle of H₂ from the anode exhaust to the combustion reaction can provide synergistic benefits for a turbine (or other combustion system) that include an exhaust gas recycle (EGR) configuration. In an EGR configuration, a portion of the CO₂-containing exhaust gas from the combustion reaction can be recycled and used as part of the input gas flow to the turbine. During operation of a combustion-powered turbine, an input gas flow of an oxidant (such as air or oxygen-enriched air) can be compressed prior to introduction into the combustion reaction. The compressors used for the input flows to the combustion reaction can tend to be volume limited, so that a similar number of moles of gas can be compressed, typically regardless of the mass of the gas. However, gases with a higher mass can tend to have higher heat capacities and/or can allow for greater pressure ratios across the expander portion of a turbine. A CO₂-enriched exhaust stream can provide a convenient source of a gas stream with higher molecular weight components that can allow for improved conversion of the energy from the combustion reaction into electric power from the turbine. Although introducing a CO₂-enriched stream into the combustion reaction can provide some benefits, there can be effective limits to the amount of the CO₂-enriched stream that can be added without significantly (negatively) impacting the combustion reaction. Since the CO₂-enriched stream does not itself typically contain “fuel”, the stream can largely act as a diluent within the combustion reaction. As a result, the amount of recyclable CO₂ can be limited based, at least in part, on maintaining the conditions in the combustion reaction within an appropriate flammability window.

[0060] Recycle of H₂ from the anode exhaust can complement an EGR configuration in one or more ways. First, combustion of H₂ may not directly result in generation of CO₂. Instead, as noted above, the CO₂ generated when the H₂ is produced can be generated in the anode loop. This can reduce the amount of CO₂ needing to be transferred from cathode to anode for a given level of power generation. Additionally, H₂ can also have the benefit of modifying the operation of the combustion source, such as through modifying the flammability window, so that higher concentrations of CO₂ can be tolerated while still maintaining a desired combustion reaction. Being able to expand the flammability window can allow for increased concentrations of CO₂ in the combustion exhaust, and therefore increased CO₂ in the input to the cathodes of the fuel cell.

[0061] The benefit of being able to increase the CO₂ concentration in the input to the fuel cell cathode can be related to the nature of how a molten carbonate fuel cell operates. As detailed below, there can be practical limits in the amount of CO₂ separable by an MCFC from a cathode exhaust stream. Depending on the operating conditions, an MCFC can lower the CO₂ content of a cathode exhaust stream to about 2.0 vol% or less, *e.g.*, about 1.5 vol% or less or about 1.2 vol% or less. Due to this limitation, the net efficiency of CO₂ removal when using molten carbonate fuel cells can be dependent on the amount of CO₂ in the cathode input. For a combustion reaction using natural gas as a fuel, the amount of CO₂ in the combustion exhaust can correspond to a CO₂ concentration at the cathode input of at least about 4 vol%. Use of exhaust gas recycle can allow the amount of CO₂ at the cathode input to be increased to at least about 5 vol%, *e.g.*, at least about 6 vol%. Due to the increased flammability window that can be provided when using H₂ as part of the fuel, the amount of CO₂ added via exhaust gas recycle can be increased still further, so that concentrations of CO₂ at the cathode input of at least about 7.5 vol% or at least about 8 vol% can be achieved. Based on a removal limit of about 1.5 vol% at the cathode exhaust, increasing the CO₂ content at the cathode input from about 5.5 vol% to about 7.5 vol% corresponds to a ~50% increase in the amount of CO₂ that can be captured using a fuel cell and transported to the anode loop for eventual CO₂ separation.

[0062] The amount of H₂ present in the anode output can be increased, for example, by using a water gas shift reactor to convert H₂O and CO present in the anode output

into H₂ and CO₂. Water is an expected output of the reaction occurring at the anode, so the anode output can typically have an excess of H₂O relative to the amount of CO present in the anode output. CO can be present in the anode output due to incomplete carbon combustion during reforming and/or due to the equilibrium balancing reactions between H₂O, CO, H₂, and CO₂ (*i.e.*, the water-gas shift equilibrium) under either reforming conditions or the conditions present during the anode reaction. A water gas shift reactor can be operated under conditions to drive the equilibrium further in the direction of forming CO₂ and H₂ at the expense of CO and H₂O. Higher temperatures can tend to favor the formation of CO and H₂O. Thus, one option for operating the water gas shift reactor can be to expose the anode output stream to a suitable catalyst, such as a catalyst including iron oxide, zinc oxide, copper on zinc oxide, or the like, at a suitable temperature, *e.g.*, between about 190°C to about 210°C. Optionally, the water-gas shift reactor can include two stages for reducing the CO concentration in an anode output stream, with a first higher temperature stage operated at a temperature from at least about 300°C to about 375°C and a second lower temperature stage operated at a temperature of about 225°C or less, such as from about 180°C to about 210°C. In addition to increasing the amount of H₂ present in the anode output, the water-gas shift reaction can also increase the amount of CO₂ at the expense of CO. This can exchange difficult-to-remove carbon monoxide (CO) for carbon dioxide, which can be more readily removed by condensation (*e.g.*, cryogenic removal), chemical reaction (such as amine removal), and/or other CO₂ removal methods.

[0063] In some aspects of the invention, all or substantially all of the anode output stream remaining after separation of (portions of) the CO₂ (and H₂O) can be recycled for use as an input for the fuel cell anode(s) and/or as a fuel input for the combustion-powered generator. Thus, for the portion of the anode output stream that remains after a water-gas shift reaction, removal of CO₂, and/or removal of H₂O, at least about 90% of the remaining content can advantageously be used as either an input for the fuel cell anode(s) or as a fuel input for the combustion powered generator. Alternatively, the anode output stream after separation can be used for more than one purpose, but recycle of any portion of the anode output stream for use as a direct input to a cathode and/or as an input to an oxidizer for heating of the fuel cell can advantageously be avoided.

[0064] FIG. 4 shows an example of the anode flow path portion of a generator/fuel cell system according to the invention. In FIG. 4, an initial fuel stream 405 can optionally be reformed 410 to convert methane (or another type of fuel) and water into H_2 and CO_2 . Alternatively, the reforming reaction can be performed in a reforming stage that is part of an assembly including both the reforming stage and the fuel cell anode 420. Additionally or alternately, at least a portion of fuel stream 405 can correspond to hydrogen gas, so that the amount of reforming needed to provide fuel to the anode 420 can be reduced and/or minimized. The optionally reformed fuel 415 can then be passed into anode 420. A recycle stream 455 including fuel components from the anode exhaust 425 can also serve as an input to the anode 420. A flow of carbonate ions 422 from the cathode portion of the fuel cell (not shown) can provide the remaining reactant needed for the anode fuel cell reactions. Based on the reactions in the anode 420, the resulting anode exhaust 425 can include H_2O , CO_2 , one or more components corresponding to unreacted fuel (H_2 , CO , CH_4 , or others), and optionally one or more additional non-reactive components, such as N_2 and/or other contaminants that are part of fuel stream 405. The anode exhaust 425 can then be passed into one or more separation stages 430 for removal of CO_2 (and optionally also H_2O). A cryogenic CO_2 removal system can be an example of a suitable type of separation stage. Optionally, the anode exhaust can first be passed through a water gas shift reactor 440 to convert any CO present in the anode exhaust (along with some H_2O) into CO_2 and H_2 in an optionally water gas shifted anode exhaust 445.

[0065] An initial portion of the separation stage(s) 430 can be used to remove a majority of the H_2O present in the anode exhaust 425 as an H_2O output stream 432. Additionally or alternately, a heat recovery steam generator system or other heat exchangers independent of the cryogenic separation system can be used to remove a portion of the H_2O . A cryogenic CO_2 removal system can then remove a majority of the CO_2 as a high purity CO_2 stream 434. A purge stream (not shown) can also be present, if desired, to prevent accumulation of inert gases within the anode recycle loop. The remaining components of the anode exhaust stream can then be used either as a recycled input 455 to the inlet of anode 420 or as an input stream 485 for a combustion powered turbine.

[0066] Conventionally, at least some reforming is performed prior to any fuel entering a fuel cell. This initial/preliminary reforming can be performed in a reformer that is external to the fuel cell(s) or fuel cell stack(s). Alternatively, the assembly for a fuel cell stack can include one or more reforming zones located within the stack but prior to the anodes of the fuel cells in the stack. This initial reforming typically converts at least some fuel into hydrogen prior to entering the anode, so that the stream that enters the anode can have sufficient hydrogen to maintain the anode reaction. Without this initial reforming, in certain embodiments, the hydrogen content in the anode can be too low, resulting in little or no transport of CO₂ from cathode to anode. By contrast, in some embodiments the fuel cell(s) in a fuel cell array can be operated without external reforming, *i.e.*, based only on reforming within the anode portion of the fuel cell, due to sufficient hydrogen being present in the recycled portion of the anode exhaust. When a sufficient amount of H₂ is present in the anode feed, such as at least about 10 vol% of the fuel delivered to the anode in the form of H₂, the reaction conditions in the anode can allow for additional reforming to take place within the anode itself, which, depending on flow path, can reduce and/or eliminate the need for a reforming stage external (prior) to the anode input(s) in the methods according to the invention. If the anode feed does not contain a sufficient amount of hydrogen, the anode reaction can stall, and reforming activity and/or other reactions in the anode can be reduced, minimized, or halted entirely. As a result, in embodiments where the amount of H₂ present in the anode feed is insufficient, it may be desirable (or necessary) for there to be a reforming stage external (prior) to the anode input(s).

Operation of Cathode Portion

[0067] In various aspects according to the invention, molten carbonate fuel cells used for carbon capture can be operated to improve or enhance the carbon capture aspects of the fuel cells, as opposed to (or even at the expense of) enhancing the power generation capabilities. Conventionally, a molten carbonate fuel cell can be operated based on providing a desirable voltage while consuming all fuel in the fuel stream delivered to the anode. This can be conventionally achieved in part by using the anode exhaust as at least a part of the cathode input stream. By contrast, the present invention uses separate/different sources for the anode input and cathode input. By removing the link between the composition of the anode input flow and the cathode input flow, additional

options become available for operating the fuel cell to improve capture of carbon dioxide.

[0068] One initial challenge in using molten carbonate fuel cells for carbon dioxide removal can be that the fuel cells have limited ability to remove carbon dioxide from relatively dilute cathode feeds. FIG. 5 shows an example of the relationship between 1) voltage and CO₂ concentration and 2) power and CO₂ concentration, based on the concentration of CO₂ in the cathode input gas. As shown in FIG. 5, the voltage and/or power generated by a carbonate fuel cell can start to drop rapidly as the CO₂ concentration falls below about 2.0 vol%. As the CO₂ concentration drops further, *e.g.*, to below 1.0 vol%, at some point the voltage across the fuel cell can become low enough that little or no further transport of carbonate may occur. Thus, at least some CO₂ is likely to be present in the exhaust gas from the cathode stage of a fuel cell, pretty much regardless of the operating conditions.

[0069] One modification of the fuel cell operating conditions can be to operate the fuel cell with an excess of available reactants at the anode, such as by operating with low fuel utilization at the anode, as described above. By providing an excess of the reactants for the anode reaction in the fuel cell, the availability of CO₂ for the cathode reaction can be used as a/the rate limiting variable for the reaction.

[0070] When operating MCFCs to enhance the amount of carbon capture, the factors for balancing can be different than when attempting to improve fuel utilization. In particular, the amount of carbon dioxide delivered to the fuel cells can be determined based on the output flow from the combustion generator providing the CO₂-containing stream. To a first approximation, the CO₂ content of the output flow from a combustion generator can be a minor portion of the flow. Even for a higher CO₂ content exhaust flow, such as the output from a coal-fired combustion generator, the CO₂ content from most commercial coal fired power plants can be about 15 vol% or less. In order to perform the cathode reaction, this could potentially include between about 5% and about 15%, typically between about 7% and about 9%, of oxygen used to react with the CO₂ to form carbonate ions. As a result, less than about 25 vol% of the input stream to the cathode can typically be consumed by the cathode reactions. The remaining at least about 75% portion of the cathode flow can be comprised of

inert/non-reactive species such as N_2 , H_2O , and other typical oxidant (air) components, along with any unreacted CO_2 and O_2 .

[0071] Based on the nature of the input flow to the cathode relative to the cathode reactions, the portion of the cathode input consumed and removed at the cathode can be about 25 vol% or less, for example about 10 vol% or less for input flows based on combustion of cleaner fuel sources, such as natural gas sources. The exact amount can vary based on the fuel used, the diluent content in the input fuel (*e.g.*, N_2 is typically present in natural gas at a small percentage), and the oxidant (air) to fuel ratio at which the combustor is operated, all of which can vary, but are typically well known for commercial operations. As a result, the total gas flow into the cathode portions of the fuel cells can be relatively predictable (constant) across the total array of fuel cells used for carbon capture. Several possible configurations can be used in order to provide an array of fuel cells to enhance/improve/optimize carbon capture. The following configuration options can be used alone or in combination as part of the strategy for improving carbon capture.

[0072] A first configuration option can be to divide the CO_2 -containing stream between a plurality of fuel cells. The CO_2 -containing output stream from an industrial generator can typically correspond to a large flow volume relative to desirable operating conditions for a single MCFC of reasonable size. Instead of processing the entire flow in a single MCFC, the flow can be divided amongst a plurality of MCFC units, usually at least some of which are in parallel, so that the flow rate in each unit can be within a desired flow range.

[0073] A second configuration option can be to utilize fuel cells in series to successively remove CO_2 from a flow stream. Regardless of the number of initial fuel cells to which a CO_2 -containing stream can be distributed to in parallel, each initial fuel cell can be followed by one or more additional cells in series to further remove additional CO_2 . Similar to the situation demonstrated in FIG. 3 for the H_2 input to the anode, attempting to remove CO_2 within a stream in a single fuel cell could lead to a low and/or unpredictable voltage output. Rather than attempting to remove CO_2 to a desired level in a single fuel cell, CO_2 can be removed in successive cells until a desired level can be achieved. For example, each cell in a series of fuel cells can be used to remove some percentage (*e.g.*, about 50%) of the CO_2 present in a fuel stream.

In such an example, if three fuel cells are used in series, the CO₂ concentration can be reduced (*e.g.*, to about 15% or less of the original amount present, which can correspond to reducing the CO₂ concentration from about 6% to about 1% or less over the course of three fuel cells in series).

[0074] In another configuration, the operating conditions can be selected in early fuel stages in series to provide a desired output voltage while the array of stages can be selected to achieve a desired level of carbon capture. As an example, an array of fuel cells can be used with three fuel cells in series. The first two fuel cells in series can be used to remove CO₂ while maintaining a desired output voltage. The final fuel cell can then be operated to remove CO₂ to a desired concentration.

[0075] In still another configuration, there can be separate connectivity for the anodes and cathodes in a fuel cell array. For example, if the fuel cell array includes fuel cathodes connected in series, the corresponding anodes can be connected in any convenient manner, not necessarily matching up with the same arrangement as their corresponding cathodes, for example. This can include, for instance, connecting the anodes in parallel, so that each anode receives the same type of fuel feed, and/or connecting the anodes in a reverse series, so that the highest fuel concentration in the anodes can correspond to those cathodes having the lowest CO₂ concentration.

Hydrogen or Syngas Capture

[0076] Either hydrogen or syngas can be withdrawn from the anode exhaust as a chemical energy output. Hydrogen can be used as a clean fuel without generating greenhouse gases when it is burned or combusted. Instead, for hydrogen generated by reforming of hydrocarbons (or hydrocarbonaceous compounds), the CO₂ will have already been “captured” in the anode loop. Additionally, hydrogen can be a valuable input for a variety of refinery processes and/or other synthesis processes. Syngas can also be a valuable input for a variety of processes. In addition to having fuel value, syngas can be used as a feedstock for producing other higher value products, such as by using syngas as an input for Fischer-Tropsch synthesis and/or methanol synthesis processes.

[0077] In various aspects, the anode exhaust can have a ratio of H₂ to CO of about 1.5 : 1 to about 10 : 1, such as at least about 3.0 : 1, or at least about 4.0 : 1, or at least about 5.0 : 1, and/or about 8.0 : 1 or less or about 6.0 : 1 or less. A syngas stream can

be withdrawn from the anode exhaust. In various aspects, a syngas stream withdrawn from an anode exhaust can have a ratio of moles of H₂ to moles of CO of at least about 0.9 : 1, such as at least about 1.0 : 1, or at least about 1.2 : 1, or at least about 1.5 : 1, or at least about 1.7 : 1, or at least about 1.8 : 1, or at least about 1.9 : 1. Additionally or alternately, the molar ratio of H₂ to CO in a syngas withdrawn from an anode exhaust can be about 3.0 : 1 or less, such as about 2.7 : 1 or less, or about 2.5 : 1 or less, or about 2.3 : 1 or less, or about 2.2 : 1 or less, or about 2.1 : 1 or less. It is noted that higher ratios of H₂ to CO in a withdrawn syngas stream can tend to reduce the amount of CO relative to the amount of CO₂ in a cathode exhaust. However, many types of syngas applications benefit from syngas with a molar ratio of H₂ to CO of at least about 1.5 : 1 to about 2.5 : 1 or less, so forming a syngas stream with a molar ratio of H₂ to CO content of, for example, about 1.7 : 1 to about 2.3 : 1 may be desirable for some applications.

[0078] Syngas can be withdrawn from an anode exhaust by any convenient method. In some aspects, syngas can be withdrawn from the anode exhaust by performing separations on the anode exhaust to remove at least a portion of the components in the anode exhaust that are different from H₂ and CO. For example, an anode exhaust can first be passed through an optional water-gas shift stage to adjust the relative amounts of H₂ and CO. One or more separation stages can then be used to remove H₂O and/or CO₂ from the anode exhaust. The remaining portion of the anode exhaust can then correspond to the syngas stream, which can then be withdrawn for use in any convenient manner. Additionally or alternately, the withdrawn syngas stream can be passed through one or more water-gas shift stages and/or passed through one or more separation stages.

[0079] It is noted that an additional or alternative way of modifying the molar ratio of H₂ to CO in the withdrawn syngas can be to separate an H₂ stream from the anode exhaust and/or the syngas, such as by performing a membrane separation. Such a separation to form a separate H₂ output stream can be performed at any convenient location, such as prior to and/or after passing the anode exhaust through a water-gas shift reaction stage, and prior to and/or after passing the anode exhaust through one or more separation stages for removing components in the anode exhaust different from H₂ and CO. Optionally, a water-gas shift stage can be used both before and after

separation of an H₂ stream from the anode exhaust. In an additional or alternative embodiment, H₂ can optionally be separated from the withdrawn syngas stream. In some aspects, a separated H₂ stream can correspond to a high purity H₂ stream, such as an H₂ stream containing at least about 90 vol% of H₂, such as at least about 95 vol% of H₂ or at least about 99 vol% of H₂.

[0080] In some aspects, a molten carbonate fuel cell can be operated using a cathode input feed with a moderate or low CO₂ content. A variety of streams that are desirable for carbon separation and capture can include streams with moderate to low CO₂ content. For example, a potential input stream for a cathode inlet can have a CO₂ content of about 20 vol% or less, such as about 15 vol% or less, or about 12 vol% or less, or about 10 vol% or less. Such a CO₂-containing stream can be generated by a combustion generator, such as a coal-fired or natural gas-fired turbine. Achieving a desired level of CO₂ utilization on a cathode input stream with a moderate or low CO₂ content can allow for use of a lower content CO₂ stream, as opposed to needing to enrich a stream with CO₂ prior to using the stream as a cathode input stream. In various aspects, the CO₂ utilization for a fuel cell can be at least about 50%, such as at least about 55% or at least about 60%. Additionally or alternately, the CO₂ utilization can be about 98% or less, such as about 97% or less, or about 95% or less, or about 90% or less, or alternatively can be just high enough so that sufficient CO₂ remains in the cathode exhaust to allow efficient or desired operation of the fuel cell. As used herein, CO₂ utilization may be the difference between the moles of CO₂ in the cathode outlet stream and the moles of CO₂ in the cathode inlet stream divided by the moles of CO₂ in the cathode inlet. Expressed mathematically, CO₂ utilization = (CO₂ (cathode in) - CO₂ (cathode out)) / CO₂ (cathode in).

Operating Strategies

[0081] As an addition, complement, and/or alternative to the fuel cell operating strategies described herein, a molten carbonate fuel cell (such as a fuel cell assembly) can be operated with increased production of syngas (or hydrogen) while also reducing or minimizing the amount of CO₂ exiting the fuel cell in the cathode exhaust stream. Syngas can be a valuable input for a variety of processes. In addition to having fuel value, syngas can be used as a raw material for forming other higher value products, such as by using syngas as an input for Fischer-Tropsch synthesis and/or methanol

synthesis processes. One option for making syngas can be to reform a hydrocarbon or hydrocarbon-like fuel, such as methane or natural gas. For many types of industrial processes, a syngas having a ratio of H₂ to CO of close to 2:1 (or even lower) can often be desirable. A water gas shift reaction can be used to reduce the H₂ to CO ratio in a syngas if additional CO₂ is available, such as is produced in the anodes.

[0082] One way of characterizing the overall benefit provided by integrating syngas generation with use of molten carbonate fuel cells can be based on a ratio of the net amount of syngas that exits the fuel cells in the anode exhaust relative to the amount of CO₂ that exits the fuel cells in the cathode exhaust. This characterization measures the effectiveness of producing power with low emissions and high efficiency (both electrical and chemical). In this description, the net amount of syngas in an anode exhaust is defined as the combined number of moles of H₂ and number of moles of CO present in the anode exhaust, offset by the amount of H₂ and CO present in the anode inlet. Because the ratio is based on the net amount of syngas in the anode exhaust, simply passing excess H₂ into the anode does not change the value of the ratio. However, H₂ and/or CO generated due to reforming in the anode and/or in an internal reforming stage associated with the anode can lead to higher values of the ratio. Hydrogen oxidized in the anode can lower the ratio. It is noted that the water gas shift reaction can exchange H₂ for CO, so the combined moles of H₂ and CO represents the total potential syngas in the anode exhaust, regardless of the eventual desired ratio of H₂ to CO in a syngas. The syngas content of the anode exhaust (H₂ + CO) can then be compared with the CO₂ content of the cathode exhaust. This can provide a type of efficiency value that can also account for the amount of carbon capture. This can equivalently be expressed as an equation as

$$\text{Ratio of net syngas in anode exhaust to cathode CO}_2 = \frac{\text{net moles of (H}_2 + \text{CO)}_{\text{ANODE}}}{\text{moles of (CO}_2\text{)}_{\text{CATHODE}}}$$

[0083] In various aspects, the ratio of net moles of syngas in the anode exhaust to the moles of CO₂ in the cathode exhaust can be at least about 2.0, such as at least about 3.0, or at least about 4.0, or at least about 5.0. In some aspects, the ratio of net syngas in the anode exhaust to the amount of CO₂ in the cathode exhaust can be still higher, such as at least about 10.0, or at least about 15.0, or at least about 20.0. Ratio values of about 40.0 or less, such as about 30.0 or less, or about 20.0 or less, can additionally or

alternately be achieved. In aspects where the amount of CO₂ at the cathode inlet is about 6.0 volume % or less, such as about 5.0 volume % or less, ratio values of at least about 1.5 may be sufficient/realistic. Such molar ratio values of net syngas in the anode exhaust to the amount of CO₂ in the cathode exhaust can be greater than the values for conventionally operated fuel cells.

[0084] As an addition, complement, and/or alternative to the fuel cell operating strategies described herein, a molten carbonate fuel cell (such as a fuel cell assembly) can be operated at a reduced fuel utilization value, such as a fuel utilization of about 50% or less, while also having a high CO₂ utilization value, such as at least about 60%. In this type of configuration, the molten carbonate fuel cell can be effective for carbon capture, as the CO₂ utilization can advantageously be sufficiently high. Rather than attempting to maximize electrical efficiency, in this type of configuration the total efficiency of the fuel cell can be improved or increased based on the combined electrical and chemical efficiency. The chemical efficiency can be based on withdrawal of a hydrogen and/or syngas stream from the anode exhaust as an output for use in other processes. Even though the electrical efficiency may be reduced relative to some conventional configurations, making use of the chemical energy output in the anode exhaust can allow for a desirable total efficiency for the fuel cell.

[0085] In various aspects, the fuel utilization in the fuel cell anode can be about 50% or less, such as about 40% or less, or about 30% or less, or about 25% or less, or about 20% or less. In various aspects, in order to generate at least some electric power, the fuel utilization in the fuel cell can be at least about 5%, such as at least about 10%, or at least about 15%, or at least about 20%, or at least about 25%, or at least about 30%. Additionally or alternatively, the CO₂ utilization can be at least about 60%, such as at least about 65%, or at least about 70%, or at least about 75%.

[0086] As an addition, complement, and/or alternative to the fuel cell operating strategies described herein, a molten carbonate fuel cell can be operated so that the amount of reforming can be selected relative to the amount of oxidation in order to achieve a desired thermal ratio for the fuel cell. As used herein, the “thermal ratio” is defined as the heat produced by exothermic reactions in a fuel cell assembly divided by the endothermic heat demand of reforming reactions occurring within the fuel cell assembly. Expressed mathematically, the thermal ratio (TH) = Q_{EX}/Q_{EN} , where Q_{EX} is

the sum of heat produced by exothermic reactions and Q_{EN} is the sum of heat consumed by the endothermic reactions occurring within the fuel cell. Note that the heat produced by the exothermic reactions corresponds to any heat due to reforming reactions, water gas shift reactions, and the electrochemical reactions in the cell. The heat generated by the electrochemical reactions can be calculated based on the ideal electrochemical potential of the fuel cell reaction across the electrolyte minus the actual output voltage of the fuel cell. For example, the ideal electrochemical potential of the reaction in a MCFC is believed to be about 1.04V based on the net reaction that occurs in the cell. During operation of the MCFC, the cell will typically have an output voltage less than 1.04 V due to various losses. For example, a common output/operating voltage can be about 0.7 V. The heat generated is equal to the electrochemical potential of the cell (i.e. ~1.04V) minus the operating voltage. For example, the heat produced by the electrochemical reactions in the cell is ~0.34 V when the output voltage of ~0.7V. Thus, in this scenario, the electrochemical reactions would produce ~0.7 V of electricity and ~0.34 V of heat energy. In such an example, the ~0.7 V of electrical energy is not included as part of Q_{EX} . In other words, heat energy is not electrical energy.

[0087] In various aspects, a thermal ratio can be determined for any convenient fuel cell structure, such as a fuel cell stack, an individual fuel cell within a fuel cell stack, a fuel cell stack with an integrated reforming stage, a fuel cell stack with an integrated endothermic reaction stage, or a combination thereof. The thermal ratio may also be calculated for different units within a fuel cell stack, such as an assembly of fuel cells or fuel cell stacks. For example, the thermal ratio may be calculated for a single anode within a single fuel cell, an anode section within a fuel cell stack, or an anode section within a fuel cell stack along with integrated reforming stages and/or integrated endothermic reaction stage elements in sufficiently close proximity to the anode section to be integrated from a heat integration standpoint. As used herein, “an anode section” comprises anodes within a fuel cell stack that share a common inlet or outlet manifold.

[0088] In various aspects of the invention, the operation of the fuel cells can be characterized based on a thermal ratio. Where fuel cells are operated to have a desired thermal ratio, a molten carbonate fuel cell can be operated to have a thermal ratio of about 1.5 or less, for example about 1.3 or less, or about 1.15 or less, or about 1.0 or

less, or about 0.95 or less, or about 0.90 or less, or about 0.85 or less, or about 0.80 or less, or about 0.75 or less. Additionally or alternately, the thermal ratio can be at least about 0.25, or at least about 0.35, or at least about 0.45, or at least about 0.50. Additionally or alternately, in some aspects the fuel cell can be operated to have a temperature rise between anode input and anode output of about 40°C or less, such as about 20°C or less, or about 10°C or less. Further additionally or alternately, the fuel cell can be operated to have an anode outlet temperature that is from about 10°C lower to about 10°C higher than the temperature of the anode inlet. Still further additionally or alternately, the fuel cell can be operated to have an anode inlet temperature that is greater than the anode outlet temperature, such as at least about 5°C greater, or at least about 10°C greater, or at least about 20°C greater, or at least about 25°C greater. Yet still further additionally or alternately, the fuel cell can be operated to have an anode inlet temperature that is greater than the anode outlet temperature by about 100°C or less, such as by about 80°C or less, or about 60°C or less, or about 50°C or less, or about 40°C or less, or about 30°C or less, or about 20°C or less.

[0089] As an addition, complement, and/or alternative to the fuel cell operating strategies described herein, a molten carbonate fuel cell (such as a fuel cell assembly) can be operated with an excess of reformable fuel relative to the amount of hydrogen reacted in the anode of the fuel cell. Instead of selecting the operating conditions of a fuel cell to improve or maximize the electrical efficiency of the fuel cell, an excess of reformable fuel can be passed into the anode of the fuel cell to increase the chemical energy output of the fuel cell. Optionally but preferably, this can lead to an increase in the total efficiency of the fuel cell based on the combined electrical efficiency and chemical efficiency of the fuel cell.

[0090] In some aspects, the reformable hydrogen content of reformable fuel in the input stream delivered to the anode and/or to a reforming stage associated with the anode can be at least about 50% greater than the amount of hydrogen oxidized in the anode, such as at least about 75% greater or at least about 100% greater. In various aspects, a ratio of the reformable hydrogen content of the reformable fuel in the fuel stream relative to an amount of hydrogen reacted in the anode can be at least about 1.5 : 1, or at least about 2.0 : 1, or at least about 2.5 : 1, or at least about 3.0 : 1. Additionally or alternately, the ratio of reformable hydrogen content of the reformable

fuel in the fuel stream relative to the amount of hydrogen reacted in the anode can be about 20 : 1 or less, such as about 15 : 1 or less or about 10 : 1 or less. In one aspect, it is contemplated that less than 100% of the reformable hydrogen content in the anode inlet stream can be converted to hydrogen. For example, at least about 80% of the reformable hydrogen content in an anode inlet stream can be converted to hydrogen in the anode and/or in an associated reforming stage, such as at least about 85%, or at least about 90%.

[0091] As an addition, complement, and/or alternative to the fuel cell operating strategies described herein, a molten carbonate fuel cell (such as a fuel cell assembly) can also be operated at conditions that can improve or optimize the combined electrical efficiency and chemical efficiency of the fuel cell. Instead of selecting conventional conditions for maximizing the electrical efficiency of a fuel cell, the operating conditions can allow for output of excess synthesis gas and/or hydrogen in the anode exhaust of the fuel cell. The synthesis gas and/or hydrogen can then be used in a variety of applications, including chemical synthesis processes and collection of hydrogen for use as a “clean” fuel. In aspects of the invention, electrical efficiency can be reduced to achieve a high overall efficiency, which includes a chemical efficiency based on the chemical energy value of syngas and/or hydrogen produced relative to the energy value of the fuel input for the fuel cell.

[0092] In some aspects, the operation of the fuel cells can be characterized based on electrical efficiency. Where fuel cells are operated to have a low electrical efficiency (EE), a molten carbonate fuel cell can be operated to have an electrical efficiency of about 40% or less, for example, about 35% EE or less, about 30% EE or less, about 25% EE or less, or about 20% EE or less, about 15% EE or less, or about 10% EE or less. Additionally or alternately, the EE can be at least about 5%, or at least about 10%, or at least about 15%, or at least about 20%. Further additionally or alternately, the operation of the fuel cells can be characterized based on total fuel cell efficiency (TFCE), such as a combined electrical efficiency and chemical efficiency of the fuel cell(s). Where fuel cells are operated to have a high total fuel cell efficiency, a molten carbonate fuel cell can be operated to have a TFCE (and/or combined electrical efficiency and chemical efficiency) of about 55% or more, for example, about 60% or more, or about 65% or more, or about 70% or more, or about 75% or more, or about

80% or more, or about 85% or more. It is noted that for a total fuel cell efficiency and/or combined electrical efficiency and chemical efficiency, any additional electricity generated from use of excess heat generated by the fuel cell can be excluded from the efficiency calculation.

[0093] In various aspects of the invention, the operation of the fuel cells can be characterized based on a desired electrical efficiency of about 40% or less and a desired total fuel cell efficiency of about 55% or more. Where fuel cells are operated to have a desired electrical efficiency and a desired total fuel cell efficiency, a molten carbonate fuel cell can be operated to have an electrical efficiency of about 40% or less with a TFCE of about 55% or more, for example, about 35% EE or less with about a TFCE of 60% or more, about 30% EE or less with about a TFCE of about 65% or more, about 25% EE or less with about a 70% TFCE or more, or about 20% EE or less with about a TFCE of 75% or more, about 15% EE or less with about a TFCE of 80% or more, or about 10% EE or less with about a TFCE of about 85% or more.

[0094] As an addition, complement, and/or alternative to the fuel cell operating strategies described herein, a molten carbonate fuel cell (such as a fuel cell assembly) can be operated at conditions that can provide increased power density. The power density of a fuel cell corresponds to the actual operating voltage V_A multiplied by the current density I . For a molten carbonate fuel cell operating at a voltage V_A , the fuel cell also can tend to generate waste heat, the waste heat defined as $(V_0 - V_A) * I$ based on the differential between V_A and the ideal voltage V_0 for a fuel cell providing current density I . A portion of this waste heat can be consumed by reforming of a reformable fuel within the anode of the fuel cell. The remaining portion of this waste heat can be absorbed by the surrounding fuel cell structures and gas flows, resulting in a temperature differential across the fuel cell. Under conventional operating conditions, the power density of a fuel cell can be limited based on the amount of waste heat that the fuel cell can tolerate without compromising the integrity of the fuel cell.

[0095] In various aspects, the amount of waste heat that a fuel cell can tolerate can be increased by performing an effective amount of an endothermic reaction within the fuel cell. One example of an endothermic reaction includes steam reforming of a reformable fuel within a fuel cell anode and/or in an associated reforming stage, such as an integrated reforming stage in a fuel cell stack. By providing additional reformable

fuel to the anode of the fuel cell (or to an integrated / associated reforming stage), additional reforming can be performed so that additional waste heat can be consumed. This can reduce the amount of temperature differential across the fuel cell, thus allowing the fuel cell to operate under an operating condition with an increased amount of waste heat. The loss of electrical efficiency can be offset by the creation of an additional product stream, such as syngas and/or H₂, that can be used for various purposes including additional electricity generation further expanding the power range of the system.

[0096] In various aspects, the amount of waste heat generated by a fuel cell, $(V_0 - V_A) \cdot I$ as defined above, can be at least about 30 mW/cm², such as at least about 40 mW/cm², or at least about 50 mW/cm², or at least about 60 mW/cm², or at least about 70 mW/cm², or at least about 80 mW/cm², or at least about 100 mW/cm², or at least about 120 mW/cm², or at least about 140 mW/cm², or at least about 160 mW/cm², or at least about 180 mW/cm². Additionally or alternately, the amount of waste heat generated by a fuel cell can be less than about 250 mW/cm², such as less than about 200 mW/cm², or less than about 180 mW/cm², or less than about 165 mW/cm², or less than about 150 mW/cm².

[0097] Although the amount of waste heat being generated can be relatively high, such waste heat may not necessarily represent operating a fuel cell with poor efficiency. Instead, the waste heat can be generated due to operating a fuel cell at an increased power density. Part of improving the power density of a fuel cell can include operating the fuel cell at a sufficiently high current density. In various aspects, the current density generated by the fuel cell can be at least about 150 mA/cm², such as at least about 160 mA/cm², or at least about 170 mA/cm², or at least about 180 mA/cm², or at least about 190 mA/cm², or at least about 200 mA/cm², or at least about 225 mA/cm², or at least about 250 mA/cm². Additionally or alternately, the current density generated by the fuel cell can be about 500 mA/cm² or less, such as 450 mA/cm², or less, or 400 mA/cm², or less or 350 mA/cm², or less or 300 mA/cm² or less.

[0098] In various aspects, to allow a fuel cell to be operated with increased power generation and increased generation of waste heat, an effective amount of an endothermic reaction (such as a reforming reaction) can be performed. Alternatively, other endothermic reactions unrelated to anode operations can be used to utilize the

waste heat by interspersing “plates” or stages into the fuel cell array in thermal communication but not in fluid communication with either anodes or cathodes. The effective amount of the endothermic reaction can be performed in an associated reforming stage, an integrated reforming stage, an integrated stack element for performing an endothermic reaction, or a combination thereof. The effective amount of the endothermic reaction can correspond to an amount sufficient to reduce the temperature rise from the fuel cell inlet to the fuel cell outlet to about 100°C or less, such as about 90°C or less, or about 80°C or less, or about 70°C or less, or about 60°C or less, or about 50°C or less, or about 40°C or less, or about 30°C or less. Additionally or alternately, the effective amount of the endothermic reaction can correspond to an amount sufficient to cause a temperature decrease from the fuel cell inlet to the fuel cell outlet of about 100°C or less, such as about 90°C or less, or about 80°C or less, or about 70°C or less, or about 60°C or less, or about 50°C or less, or about 40°C or less, or about 30°C or less, or about 20°C or less, or about 10°C or less. A temperature decrease from the fuel cell inlet to the fuel cell outlet can occur when the effective amount of the endothermic reaction exceeds the waste heat generated. Additionally or alternately, this can correspond to having the endothermic reaction(s) (such as a combination of reforming and another endothermic reaction) consume at least about 40% of the waste heat generated by the fuel cell, such as consuming at least about 50% of the waste heat, or at least about 60% of the waste heat, or at least about 75% of the waste heat. Further additionally or alternately, the endothermic reaction(s) can consume about 95% of the waste heat or less, such as about 90% of the waste heat or less, or about 85% of the waste heat or less.

Definitions

[0099] Syngas: In this description, syngas is defined as mixture of H₂ and CO in any ratio. Optionally, H₂O and/or CO₂ may be present in the syngas. Optionally, inert compounds (such as nitrogen) and residual reformable fuel compounds may be present in the syngas. If components other than H₂ and CO are present in the syngas, the combined volume percentage of H₂ and CO in the syngas can be at least 25 vol% relative to the total volume of the syngas, such as at least 40 vol%, or at least 50 vol%, or at least 60 vol%. Additionally or alternately, the combined volume percentage of H₂

and CO in the syngas can be 100 vol% or less, such as 95 vol% or less or 90 vol% or less.

[00100] Reformable fuel: A reformable fuel is defined as a fuel that contains carbon-hydrogen bonds that can be reformed to generate H₂. Hydrocarbons are examples of reformable fuels, as are other hydrocarbonaceous compounds such as alcohols. Although CO and H₂O can participate in a water gas shift reaction to form hydrogen, CO is not considered a reformable fuel under this definition.

[00101] Reformable hydrogen content: The reformable hydrogen content of a fuel is defined as the number of H₂ molecules that can be derived from a fuel by reforming the fuel and then driving the water gas shift reaction to completion to maximize H₂ production. It is noted that H₂ by definition has a reformable hydrogen content of 1, although H₂ itself is not defined as a reformable fuel herein. Similarly, CO has a reformable hydrogen content of 1. Although CO is not strictly reformable, driving the water gas shift reaction to completion will result in exchange of a CO for an H₂. As examples of reformable hydrogen content for reformable fuels, the reformable hydrogen content of methane is 4 H₂ molecules while the reformable hydrogen content of ethane is 7 H₂ molecules. More generally, if a fuel has the composition C_xH_yO_z, then the reformable hydrogen content of the fuel at 100% reforming and water-gas shift is $n(\text{H}_2 \text{ max reforming}) = 2x + y/2 - z$. Based on this definition, fuel utilization within a cell can then be expressed as $n(\text{H}_2 \text{ ox})/n(\text{H}_2 \text{ max reforming})$. Of course, the reformable hydrogen content of a mixture of components can be determined based on the reformable hydrogen content of the individual components. The reformable hydrogen content of compounds that contain other heteroatoms, such as oxygen, sulfur or nitrogen, can also be calculated in a similar manner.

[00102] Oxidation Reaction: In this discussion, the oxidation reaction within the anode of a fuel cell is defined as the reaction corresponding to oxidation of H₂ by reaction with CO₃²⁻ to form H₂O and CO₂. It is noted that the reforming reaction within the anode, where a compound containing a carbon-hydrogen bond is converted into H₂ and CO or CO₂, is excluded from this definition of the oxidation reaction in the anode. The water-gas shift reaction is similarly outside of this definition of the oxidation reaction. It is further noted that references to a combustion reaction are defined as references to reactions where H₂ or a compound containing carbon-hydrogen bond(s)

are reacted with O₂ to form H₂O and carbon oxides in a non-electrochemical burner, such as the combustion zone of a combustion-powered generator.

[00103] Aspects of the invention can adjust anode fuel parameters to achieve a desired operating range for the fuel cell. Anode fuel parameters can be characterized directly, and/or in relation to other fuel cell processes in the form of one or more ratios. For example, the anode fuel parameters can be controlled to achieve one or more ratios including a fuel utilization, a fuel cell heating value utilization, a fuel surplus ratio, a reformable fuel surplus ratio, a reformable hydrogen content fuel ratio, and combinations thereof.

[00104] **Fuel utilization:** Fuel utilization is an option for characterizing operation of the anode based on the amount of oxidized fuel relative to the reformable hydrogen content of an input stream can be used to define a fuel utilization for a fuel cell. In this discussion, “fuel utilization” is defined as the ratio of the amount of hydrogen oxidized in the anode for production of electricity (as described above) versus the reformable hydrogen content of the anode input (including any associated reforming stages). Reformable hydrogen content has been defined above as the number of H₂ molecules that can be derived from a fuel by reforming the fuel and then driving the water gas shift reaction to completion to maximize H₂ production. For example, each methane introduced into an anode and exposed to steam reforming conditions results in generation of the equivalent of 4 H₂ molecules at max production. (Depending on the reforming and/or anode conditions, the reforming product can correspond to a non-water gas shifted product, where one or more of the H₂ molecules is present instead in the form of a CO molecule.) Thus, methane is defined as having a reformable hydrogen content of 4 H₂ molecules. As another example, under this definition ethane has a reformable hydrogen content of 7 H₂ molecules.

[00105] The utilization of fuel in the anode can also be characterized by defining a heating value utilization based on a ratio of the Lower Heating Value of hydrogen oxidized in the anode due to the fuel cell anode reaction relative to the Lower Heating Value of all fuel delivered to the anode and/or a reforming stage associated with the anode. The “fuel cell heating value utilization” as used herein can be computed using the flow rates and Lower Heating Value (LHV) of the fuel components entering and leaving the fuel cell anode. As such, fuel cell heating value utilization can be computed

as $(LHV(\text{anode_in}) - LHV(\text{anode_out}))/LHV(\text{anode_in})$, where $LHV(\text{anode_in})$ and $LHV(\text{anode_out})$ refer to the LHV of the fuel components (such as H_2 , CH_4 , and/or CO) in the anode inlet and outlet streams or flows, respectively. In this definition, the LHV of a stream or flow may be computed as a sum of values for each fuel component in the input and/or output stream. The contribution of each fuel component to the sum can correspond to the fuel component's flow rate (e.g., mol/hr) multiplied by the fuel component's LHV (e.g., joules/mol).

[00106] Lower Heating Value: The lower heating value is defined as the enthalpy of combustion of a fuel component to vapor phase, fully oxidized products (i.e., vapor phase CO_2 and H_2O product). For example, any CO_2 present in an anode input stream does not contribute to the fuel content of the anode input, since CO_2 is already fully oxidized. For this definition, the amount of oxidation occurring in the anode due to the anode fuel cell reaction is defined as oxidation of H_2 in the anode as part of the electrochemical reaction in the anode, as defined above.

[00107] It is noted that, for the special case where the only fuel in the anode input flow is H_2 , the only reaction involving a fuel component that can take place in the anode represents the conversion of H_2 into H_2O . In this special case, the fuel utilization simplifies to $(H_2\text{-rate-in} - H_2\text{-rate-out})/H_2\text{-rate-in}$. In such a case, H_2 would be the only fuel component, and so the H_2 LHV would cancel out of the equation. In the more general case, the anode feed may contain, for example, CH_4 , H_2 , and CO in various amounts. Because these species can typically be present in different amounts in the anode outlet, the summation as described above can be needed to determine the fuel utilization.

[00108] Alternatively or in addition to fuel utilization, the utilization for other reactants in the fuel cell can be characterized. For example, the operation of a fuel cell can additionally or alternately be characterized with regard to " CO_2 utilization" and/or "oxidant" utilization. The values for CO_2 utilization and/or oxidant utilization can be specified in a similar manner.

[00109] Fuel surplus ratio: Still another way to characterize the reactions in a molten carbonate fuel cell is by defining a utilization based on a ratio of the Lower Heating Value of all fuel delivered to the anode and/or a reforming stage associated with the anode relative to the Lower Heating Value of hydrogen oxidized in the anode due to the

fuel cell anode reaction. This quantity will be referred to as a fuel surplus ratio. As such the fuel surplus ratio can be computed as $(LHV(\text{anode_in}) / (LHV(\text{anode_in}) - LHV(\text{anode_out})))$ where $LHV(\text{anode_in})$ and $LHV(\text{anode_out})$ refer to the LHV of the fuel components (such as H_2 , CH_4 , and/or CO) in the anode inlet and outlet streams or flows, respectively. In various aspects of the invention, a molten carbonate fuel cell can be operated to have a fuel surplus ratio of at least about 1.0, such as at least about 1.5, or at least about 2.0, or at least about 2.5, or at least about 3.0, or at least about 4.0. Additionally or alternately, the fuel surplus ratio can be about 25.0 or less.

[00110] It is noted that not all of the reformable fuel in the input stream for the anode may be reformed. Preferably, at least about 90% of the reformable fuel in the input stream to the anode (and/or into an associated reforming stage) can be reformed prior to exiting the anode, such as at least about 95% or at least about 98%. In some alternative aspects, the amount of reformable fuel that is reformed can be from about 75% to about 90%, such as at least about 80%.

[00111] The above definition for fuel surplus ratio provides a method for characterizing the amount of reforming occurring within the anode and/or reforming stage(s) associated with a fuel cell relative to the amount of fuel consumed in the fuel cell anode for generation of electric power.

[00112] Optionally, the fuel surplus ratio can be modified to account for situations where fuel is recycled from the anode output to the anode input. When fuel (such as H_2 , CO , and/or unreformed or partially reformed hydrocarbons) is recycled from anode output to anode input, such recycled fuel components do not represent a surplus amount of reformable or reformed fuel that can be used for other purposes. Instead, such recycled fuel components merely indicate a desire to reduce fuel utilization in a fuel cell.

[00113] **Reformable fuel surplus ratio:** Calculating a reformable fuel surplus ratio is one option to account for such recycled fuel components is to narrow the definition of surplus fuel, so that only the LHV of reformable fuels is included in the input stream to the anode. As used herein the “reformable fuel surplus ratio” is defined as the Lower Heating Value of reformable fuel delivered to the anode and/or a reforming stage associated with the anode relative to the Lower Heating Value of hydrogen oxidized in the anode due to the fuel cell anode reaction. Under the definition for reformable fuel

surplus ratio, the LHV of any H₂ or CO in the anode input is excluded. Such an LHV of reformable fuel can still be measured by characterizing the actual composition entering a fuel cell anode, so no distinction between recycled components and fresh components needs to be made. Although some non-reformed or partially reformed fuel may also be recycled, in most aspects the majority of the fuel recycled to the anode can correspond to reformed products such as H₂ or CO. Expressed mathematically, the reformable fuel surplus ratio (R_{RFS}) = LHV_{RF} / LHV_{OH} , where LHV_{RF} is the Lower Heating Value (LHV) of the reformable fuel and LHV_{OH} is the Lower Heating Value (LHV) of the hydrogen oxidized in the anode. The LHV of the hydrogen oxidized in the anode may be calculated by subtracting the LHV of the anode outlet stream from the LHV of the anode inlet stream (e.g., $LHV(\text{anode_in}) - LHV(\text{anode_out})$). In various aspects of the invention, a molten carbonate fuel cell can be operated to have a reformable fuel surplus ratio of at least about 0.25, such as at least about 0.5, or at least about 1.0, or at least about 1.5, or at least about 2.0, or at least about 2.5, or at least about 3.0, or at least about 4.0. Additionally or alternately, the reformable fuel surplus ratio can be about 25.0 or less. It is noted that this narrower definition based on the amount of reformable fuel delivered to the anode relative to the amount of oxidation in the anode can distinguish between two types of fuel cell operation methods that have low fuel utilization. Some fuel cells achieve low fuel utilization by recycling a substantial portion of the anode output back to the anode input. This recycle can allow any hydrogen in the anode input to be used again as an input to the anode. This can reduce the amount of reforming, as even though the fuel utilization is low for a single pass through the fuel cell, at least a portion of the unused fuel is recycled for use in a later pass. Thus, fuel cells with a wide variety of fuel utilization values may have the same ratio of reformable fuel delivered to the anode reforming stage(s) versus hydrogen oxidized in the anode reaction. In order to change the ratio of reformable fuel delivered to the anode reforming stages relative to the amount of oxidation in the anode, either an anode feed with a native content of non-reformable fuel needs to be identified, or unused fuel in the anode output needs to be withdrawn for other uses, or both.

[00114] Reformable hydrogen surplus ratio: Still another option for characterizing the operation of a fuel cell is based on a “reformable hydrogen surplus ratio.” The reformable fuel surplus ratio defined above is defined based on the lower heating value

of reformable fuel components. The reformable hydrogen surplus ratio is defined as the reformable hydrogen content of reformable fuel delivered to the anode and/or a reforming stage associated with the anode relative to the hydrogen reacted in the anode due to the fuel cell anode reaction. As such, the “reformable hydrogen surplus ratio” can be computed as $(\text{RFC}(\text{reformable_anode_in}) / (\text{RFC}(\text{reformable_anode_in}) - \text{RFC}(\text{anode_out})))$, where $\text{RFC}(\text{reformable_anode_in})$ refers to the reformable hydrogen content of reformable fuels in the anode inlet streams or flows, while $\text{RFC}(\text{anode_out})$ refers to the reformable hydrogen content of the fuel components (such as H_2 , CH_4 , and/or CO) in the anode inlet and outlet streams or flows. The RFC can be expressed in moles/s, moles/hr, or similar. An example of a method for operating a fuel cell with a large ratio of reformable fuel delivered to the anode reforming stage(s) versus amount of oxidation in the anode can be a method where excess reforming is performed in order to balance the generation and consumption of heat in the fuel cell. Reforming a reformable fuel to form H_2 and CO is an endothermic process. This endothermic reaction can be countered by the generation of electrical current in the fuel cell, which can also produce excess heat corresponding (roughly) to the difference between the amount of heat generated by the anode oxidation reaction and the carbonate formation reaction and the energy that exits the fuel cell in the form of electric current. The excess heat per mole of hydrogen involved in the anode oxidation reaction / carbonate formation reaction can be greater than the heat absorbed to generate a mole of hydrogen by reforming. As a result, a fuel cell operated under conventional conditions can exhibit a temperature increase from inlet to outlet. Instead of this type of conventional operation, the amount of fuel reformed in the reforming stages associated with the anode can be increased. For example, additional fuel can be reformed so that the heat generated by the exothermic fuel cell reactions can be (roughly) balanced by the heat consumed in reforming, or even the heat consumed by reforming can be beyond the excess heat generated by the fuel oxidation, resulting in a temperature drop across the fuel cell. This can result in a substantial excess of hydrogen relative to the amount needed for electrical power generation. As one example, a feed to the anode inlet of a fuel cell or an associated reforming stage can be substantially composed of reformable fuel, such as a substantially pure methane feed. During conventional operation for electric power generation using such a fuel, a molten carbonate fuel cell can be

operated with a fuel utilization of about 75%. This means that about 75% (or $\frac{3}{4}$) of the fuel content delivered to the anode is used to form hydrogen that is then reacted in the anode with carbonate ions to form H₂O and CO₂. In conventional operation, the remaining about 25% of the fuel content can be reformed to H₂ within the fuel cell (or can pass through the fuel cell unreacted for any CO or H₂ in the fuel), and then combusted outside of the fuel cell to form H₂O and CO₂ to provide heat for the cathode inlet to the fuel cell. The reformable hydrogen surplus ratio in this situation can be $4/(4-1) = 4/3$.

[00115] Electrical efficiency: As used herein, the term “electrical efficiency” (“EE”) is defined as the electrochemical power produced by the fuel cell divided by the rate of Lower Heating Value (“LHV”) of fuel input to the fuel cell. The fuel inputs to the fuel cell includes both fuel delivered to the anode as well as any fuel used to maintain the temperature of the fuel cell, such as fuel delivered to a burner associated with a fuel cell. In this description, the power produced by the fuel may be described in terms of LHV(el) fuel rate.

[00116] Electrochemical power: As used herein, the term “electrochemical power” or LHV(el) is the power generated by the circuit connecting the cathode to the anode in the fuel cell and the transfer of carbonate ions across the fuel cell’s electrolyte. Electrochemical power excludes power produced or consumed by equipment upstream or downstream from the fuel cell. For example, electricity produced from heat in a fuel cell exhaust stream is not considered part of the electrochemical power. Similarly, power generated by a gas turbine or other equipment upstream of the fuel cell is not part of the electrochemical power generated. The “electrochemical power” does not take electrical power consumed during operation of the fuel cell into account, or any loss incurred by conversion of the direct current to alternating current. In other words, electrical power used to supply the fuel cell operation or otherwise operate the fuel cell is not subtracted from the direct current power produced by the fuel cell. As used herein, the power density is the current density multiplied by voltage. As used herein, the total fuel cell power is the power density multiplied by the fuel cell area.

[00117] Fuel inputs: As used herein, the term “anode fuel input,” designated as LHV(anode_in), is the amount of fuel within the anode inlet stream. The term “fuel input”, designated as LHV(in), is the total amount of fuel delivered to the fuel cell,

including both the amount of fuel within the anode inlet stream and the amount of fuel used to maintain the temperature of the fuel cell. The fuel may include both reformable and nonreformable fuels, based on the definition of a reformable fuel provided herein. Fuel input is not the same as fuel utilization.

[00118] Total fuel cell efficiency: As used herein, the term “total fuel cell efficiency” (“TFCE”) is defined as: the electrochemical power generated by the fuel cell, plus the rate of LHV of syngas produced by the fuel cell, divided by the rate of LHV of fuel input to the anode. In other words, $TFCE = (LHV(e) + LHV(sg\ net))/LHV(anode_in)$, where $LHV(anode_in)$ refers to rate at which the LHV of the fuel components (such as H_2 , CH_4 , and/or CO) delivered to the anode and $LHV(sg\ net)$ refers to a rate at which syngas (H_2 , CO) is produced in the anode, which is the difference between syngas input to the anode and syngas output from the anode. $LHV(e)$ describes the electrochemical power generation of the fuel cell. The total fuel cell efficiency excludes heat generated by the fuel cell that is put to beneficial use outside of the fuel cell. In operation, heat generated by the fuel cell may be put to beneficial use by downstream equipment. For example, the heat may be used to generate additional electricity or to heat water. These uses, when they occur apart from the fuel cell, are not part of the total fuel cell efficiency, as the term is used in this application. The total fuel cell efficiency is for the fuel cell operation only, and does not include power production, or consumption, upstream, or downstream, of the fuel cell.

[00119] Chemical efficiency: As used herein, the term “chemical efficiency”, is defined as the lower heating value of H_2 and CO in the anode exhaust of the fuel cell, or $LHV(sg\ out)$, divided by the fuel input, or $LHV(in)$.

[00120] Neither the electrical efficiency nor the total system efficiency takes the efficiency of upstream or downstream processes into consideration. For example, it may be advantageous to use turbine exhaust as a source of CO_2 for the fuel cell cathode. In this arrangement, the efficiency of the turbine is not considered as part of the electrical efficiency or the total fuel cell efficiency calculation. Similarly, outputs from the fuel cell may be recycled as inputs to the fuel cell. A recycle loop is not considered when calculating electrical efficiency or the total fuel cell efficiency in single pass mode.

[00121] Syngas produced: As used herein, the term “syngas produced” is the difference between syngas input to the anode and syngas output from the anode. Syngas may be used as an input, or fuel, for the anode, at least in part. For example, a system may include an anode recycle loop that returns syngas from the anode exhaust to the anode inlet where it is supplemented with natural gas or other suitable fuel. Syngas produced LHV (sg net) = (LHV(sg out) - LHV(sg in)), where LHV(sg in) and LHV(sg out) refer to the LHV of the syngas in the anode inlet and syngas in the anode outlet streams or flows, respectively. It is noted that at least a portion of the syngas produced by the reforming reactions within an anode can typically be utilized in the anode to produce electricity. The hydrogen utilized to produce electricity is not included in the definition of “syngas produced” because it does not exit the anode. As used herein, the term “syngas ratio” is the LHV of the net syngas produced divided by the LHV of the fuel input to the anode or LHV (sg net)/LHV(anode in). Molar flow rates of syngas and fuel can be used instead of LHV to express a molar-based syngas ratio and a molar-based syngas produced.

[00122] Steam to carbon ratio (S/C): As used herein, the steam to carbon ratio (S/C) is the molar ratio of steam in a flow to reformable carbon in the flow. Carbon in the form of CO and CO₂ are not included as reformable carbon in this definition. The steam to carbon ratio can be measured and/or controlled at different points in the system. For example, the composition of an anode inlet stream can be manipulated to achieve a S/C that is suitable for reforming in the anode. The S/C can be given as the molar flow rate of H₂O divided by the product of the molar flow rate of fuel multiplied by the number of carbon atoms in the fuel, e.g. one for methane. Thus, $S/C = f_{H_2O} / (f_{CH_4} \times \#C)$, where f_{H_2O} is the molar flow rate of water, where f_{CH_4} is the molar flow rate of methane (or other fuel) and #C is the number of carbons in the fuel.

[00123] EGR ratio: Aspects of the invention can use a turbine in partnership with a fuel cell. The combined fuel cell and turbine system may include exhaust gas recycle (“EGR”). In an EGR system, at least a portion of the exhaust gas generated by the turbine can be sent to a heat recovery generator. Another portion of the exhaust gas can be sent to the fuel cell. The EGR ratio describes the amount of exhaust gas routed to the fuel cell versus the total exhaust gas routed to either the fuel cell or heat recovery generator. As used herein, the “EGR ratio” is the flow rate for the fuel cell bound

portion of the exhaust gas divided by the combined flow rate for the fuel cell bound portion and the recovery bound portion, which is sent to the heat recovery generator.

[00124] In various aspects of the invention, a molten carbonate fuel cell (MCFC) can be used to facilitate separation of CO₂ from a CO₂-containing stream while also generating additional electrical power. The CO₂ separation can be further enhanced by taking advantage of synergies with the combustion-based power generator that can provide at least a portion of the input feed to the cathode portion of the fuel cell.

[00125] **Fuel Cell and Fuel Cell Components:** In this discussion, a fuel cell can correspond to a single cell, with an anode and a cathode separated by an electrolyte. The anode and cathode can receive input gas flows to facilitate the respective anode and cathode reactions for transporting charge across the electrolyte and generating electricity. A fuel cell stack can represent a plurality of cells in an integrated unit. Although a fuel cell stack can include multiple fuel cells, the fuel cells can typically be connected in parallel and can function (approximately) as if they collectively represented a single fuel cell of a larger size. When an input flow is delivered to the anode or cathode of a fuel cell stack, the fuel stack can include flow channels for dividing the input flow between each of the cells in the stack and flow channels for combining the output flows from the individual cells. In this discussion, a fuel cell array can be used to refer to a plurality of fuel cells (such as a plurality of fuel cell stacks) that are arranged in series, in parallel, or in any other convenient manner (e.g., in a combination of series and parallel). A fuel cell array can include one or more stages of fuel cells and/or fuel cell stacks, where the anode/cathode output from a first stage may serve as the anode/cathode input for a second stage. It is noted that the anodes in a fuel cell array do not have to be connected in the same way as the cathodes in the array. For convenience, the input to the first anode stage of a fuel cell array may be referred to as the anode input for the array, and the input to the first cathode stage of the fuel cell array may be referred to as the cathode input to the array. Similarly, the output from the final anode/cathode stage may be referred to as the anode/cathode output from the array.

[00126] It should be understood that reference to use of a fuel cell herein typically denotes a “fuel cell stack” composed of individual fuel cells, and more generally refers to use of one or more fuel cell stacks in fluid communication. Individual fuel cell

elements (plates) can typically be “stacked” together in a rectangular array called a “fuel cell stack”. This fuel cell stack can typically take a feed stream and distribute reactants among all of the individual fuel cell elements and can then collect the products from each of these elements. When viewed as a unit, the fuel cell stack in operation can be taken as a whole even though composed of many (often tens or hundreds) of individual fuel cell elements. These individual fuel cell elements can typically have similar voltages (as the reactant and product concentrations are similar), and the total power output can result from the summation of all of the electrical currents in all of the cell elements, when the elements are electrically connected in series. Stacks can also be arranged in a series arrangement to produce high voltages. A parallel arrangement can boost the current. If a sufficiently large volume fuel cell stack is available to process a given exhaust flow, the systems and methods described herein can be used with a single molten carbonate fuel cell stack. In other aspects of the invention, a plurality of fuel cell stacks may be desirable or needed for a variety of reasons.

[00127] For the purposes of this invention, unless otherwise specified, the term “fuel cell” should be understood to also refer to and/or is defined as including a reference to a fuel cell stack composed of set of one or more individual fuel cell elements for which there is a single input and output, as that is the manner in which fuel cells are typically employed in practice. Similarly, the term fuel cells (plural), unless otherwise specified, should be understood to also refer to and/or is defined as including a plurality of separate fuel cell stacks. In other words, all references within this document, unless specifically noted, can refer interchangeably to the operation of a fuel cell stack as a “fuel cell”. For example, the volume of exhaust generated by a commercial scale combustion generator may be too large for processing by a fuel cell (i.e., a single stack) of conventional size. In order to process the full exhaust, a plurality of fuel cells (i.e., two or more separate fuel cells or fuel cell stacks) can be arranged in parallel, so that each fuel cell can process (roughly) an equal portion of the combustion exhaust. Although multiple fuel cells can be used, each fuel cell can typically be operated in a generally similar manner, given its (roughly) equal portion of the combustion exhaust.

[00128] “Internal reforming” and “external reforming”: A fuel cell or fuel cell stack may include one or more internal reforming sections. As used herein, the term

“internal reforming” refers to fuel reforming occurring within the body of a fuel cell, a fuel cell stack, or otherwise within a fuel cell assembly. External reforming, which is often used in conjunction with a fuel cell, occurs in a separate piece of equipment that is located outside of the fuel cell stack. In other words, the body of the external reformer is not in direct physical contact with the body of a fuel cell or fuel cell stack. In a typical set up, the output from the external reformer can be fed to the anode inlet of a fuel cell. Unless otherwise noted specifically, the reforming described within this application is internal reforming.

[00129] Internal reforming may occur within a fuel cell anode. Internal reforming can additionally or alternately occur within an internal reforming element integrated within a fuel cell assembly. The integrated reforming element may be located between fuel cell elements within a fuel cell stack. In other words, one of the trays in the stack can be a reforming section instead of a fuel cell element. In one aspect, the flow arrangement within a fuel cell stack directs fuel to the internal reforming elements and then into the anode portion of the fuel cells. Thus, from a flow perspective, the internal reforming elements and fuel cell elements can be arranged in series within the fuel cell stack. As used herein, the term “anode reforming” is fuel reforming that occurs within an anode. As used herein, the term “internal reforming” is reforming that occurs within an integrated reforming element and not in an anode section.

[00130] In some aspects, a reforming stage that is internal to a fuel cell assembly can be considered to be associated with the anode(s) in the fuel cell assembly. In some alternative aspects, for a reforming stage in a fuel cell stack that can be associated with an anode (such as associated with multiple anodes), a flow path can be available so that the output flow from the reforming stage is passed into at least one anode. This can correspond to having an initial section of a fuel cell plate not in contact with the electrolyte and instead can serve just as a reforming catalyst. Another option for an associated reforming stage can be to have a separate integrated reforming stage as one of the elements in a fuel cell stack, where the output from the integrated reforming stage can be returned to the input side of one or more of the fuel cells in the fuel cell stack.

[00131] From a heat integration standpoint, a characteristic height in a fuel cell stack can be the height of an individual fuel cell stack element. It is noted that the separate

reforming stage and/or a separate endothermic reaction stage could have a different height in the stack than a fuel cell. In such a scenario, the height of a fuel cell element can be used as the characteristic height. In some aspects, an integrated endothermic reaction stage can be defined as a stage that is heat integrated with one or more fuel cells, so that the integrated endothermic reaction stage can use the heat from the fuel cells as a heat source for the endothermic reaction. Such an integrated endothermic reaction stage can be defined as being positioned less than 5 times the height of a stack element from any fuel cells providing heat to the integrated stage. For example, an integrated endothermic reaction stage (such as a reforming stage) can be positioned less than 5 times the height of a stack element from any fuel cells that are heat integrated, such as less than 3 times the height of a stack element. In this discussion, an integrated reforming stage and/or integrated endothermic reaction stage that represent an adjacent stack element to a fuel cell element can be defined as being about one stack element height or less away from the adjacent fuel cell element.

[00132] In some aspects, a separate reforming stage that is heat integrated with a fuel cell element can correspond to a reforming stage associated with the fuel cell element. In such aspects, an integrated fuel cell element can provide at least a portion of the heat to the associated reforming stage, and the associated reforming stage can provide at least a portion of the reforming stage output to the integrated fuel cell as a fuel stream. In other aspects, a separate reforming stage can be integrated with a fuel cell for heat transfer without being associated with the fuel cell. In this type of situation, the separate reforming stage can receive heat from the fuel cell, but the decision can be made not to use the output of the reforming stage as an input to the fuel cell. Instead, the decision can be made to use the output of such a reforming stage for another purpose, such as directly adding the output to the anode exhaust stream, and/or for forming a separate output stream from the fuel cell assembly.

[00133] More generally, a separate stack element in a fuel cell stack can be used to perform any convenient type of endothermic reaction that can take advantage of the waste heat provided by integrated fuel cell stack elements. Instead of plates suitable for performing a reforming reaction on a hydrocarbon fuel stream, a separate stack element can have plates suitable for catalyzing another type of endothermic reaction. A manifold or other arrangement of inlet conduits in the fuel cell stack can be used to

provide an appropriate input flow to each stack element. A similar manifold or other arrangement of outlet conduits can additionally or alternately be used to withdraw the output flows from each stack element. Optionally, the output flows from an endothermic reaction stage in a stack can be withdrawn from the fuel cell stack without having the output flow pass through a fuel cell anode. In such an optional aspect, the products of the exothermic reaction can therefore exit from the fuel cell stack without passing through a fuel cell anode. Examples of other types of endothermic reactions that can be performed in stack elements in a fuel cell stack can include, without limitation, ethanol dehydration to form ethylene and ethane cracking.

[00134] Recycle: As defined herein, recycle of a portion of a fuel cell output (such as an anode exhaust or a stream separated or withdrawn from an anode exhaust) to a fuel cell inlet can correspond to a direct or indirect recycle stream. A direct recycle of a stream to a fuel cell inlet is defined as recycle of the stream without passing through an intermediate process, while an indirect recycle involves recycle after passing a stream through one or more intermediate processes. For example, if the anode exhaust is passed through a CO₂ separation stage prior to recycle, this is considered an indirect recycle of the anode exhaust. If a portion of the anode exhaust, such as an H₂ stream withdrawn from the anode exhaust, is passed into a gasifier for converting coal into a fuel suitable for introduction into the fuel cell, then that is also considered an indirect recycle.

Anode Inputs and Outputs

[00135] In various aspects of the invention, the MCFC array can be fed by a fuel received at the anode inlet that comprises, for example, both hydrogen and a hydrocarbon such as methane (or alternatively a hydrocarbonaceous or hydrocarbon-like compound that may contain heteroatoms different from C and H). Most of the methane (or other hydrocarbonaceous or hydrocarbon-like compound) fed to the anode can typically be fresh methane. In this description, a fresh fuel such as fresh methane refers to a fuel that is not recycled from another fuel cell process. For example, methane recycled from the anode outlet stream back to the anode inlet may not be considered “fresh” methane, and can instead be described as reclaimed methane. The fuel source used can be shared with other components, such as a turbine that uses a portion of the fuel source to provide a CO₂-containing stream for the cathode input.

The fuel source input can include water in a proportion to the fuel appropriate for reforming the hydrocarbon (or hydrocarbon-like) compound in the reforming section that generates hydrogen. For example, if methane is the fuel input for reforming to generate H₂, the molar ratio of water to fuel can be from about one to one to about ten to one, such as at least about two to one. A ratio of four to one or greater is typical for external reforming, but lower values can be typical for internal reforming. To the degree that H₂ is a portion of the fuel source, in some optional aspects no additional water may be needed in the fuel, as the oxidation of H₂ at the anode can tend to produce H₂O that can be used for reforming the fuel. The fuel source can also optionally contain components incidental to the fuel source (e.g., a natural gas feed can contain some content of CO₂ as an additional component). For example, a natural gas feed can contain CO₂, N₂, and/or other inert (noble) gases as additional components. Optionally, in some aspects the fuel source may also contain CO, such as CO from a recycled portion of the anode exhaust. An additional or alternate potential source for CO in the fuel into a fuel cell assembly can be CO generated by steam reforming of a hydrocarbon fuel performed on the fuel prior to entering the fuel cell assembly.

[00136] More generally, a variety of types of fuel streams may be suitable for use as an input stream for the anode of a molten carbonate fuel cell. Some fuel streams can correspond to streams containing hydrocarbons and/or hydrocarbon-like compounds that may also include heteroatoms different from C and H. In this discussion, unless otherwise specified, a reference to a fuel stream containing hydrocarbons for an MCFC anode is defined to include fuel streams containing such hydrocarbon-like compounds. Examples of hydrocarbon (including hydrocarbon-like) fuel streams include natural gas, streams containing C1 – C4 carbon compounds (such as methane or ethane), and streams containing heavier C5+ hydrocarbons (including hydrocarbon-like compounds), as well as combinations thereof. Still other additional or alternate examples of potential fuel streams for use in an anode input can include biogas-type streams, such as methane produced from natural (biological) decomposition of organic material.

[00137] In some aspects, a molten carbonate fuel cell can be used to process an input fuel stream, such as a natural gas and/or hydrocarbon stream, with a low energy content due to the presence of diluent compounds. For example, some sources of methane

and/or natural gas are sources that can include substantial amounts of either CO₂ or other inert molecules, such as nitrogen, argon, or helium. Due to the presence of elevated amounts of CO₂ and/or inerts, the energy content of a fuel stream based on the source can be reduced. Using a low energy content fuel for a combustion reaction (such as for powering a combustion-powered turbine) can pose difficulties. However, a molten carbonate fuel cell can generate power based on a low energy content fuel source with a reduced or minimal impact on the efficiency of the fuel cell. The presence of additional gas volume can require additional heat for raising the temperature of the fuel to the temperature for reforming and/or the anode reaction. Additionally, due to the equilibrium nature of the water gas shift reaction within a fuel cell anode, the presence of additional CO₂ can have an impact on the relative amounts of H₂ and CO present in the anode output. However, the inert compounds otherwise can have only a minimal direct impact on the reforming and anode reactions. The amount of CO₂ and/or inert compounds in a fuel stream for a molten carbonate fuel cell, when present, can be at least about 1 vol%, such as at least about 2 vol%, or at least about 5 vol%, or at least about 10 vol%, or at least about 15 vol%, or at least about 20 vol%, or at least about 25 vol%, or at least about 30 vol%, or at least about 35 vol%, or at least about 40 vol%, or at least about 45 vol%, or at least about 50 vol %, or at least about 75 vol%. Additionally or alternately, the amount of CO₂ and/or inert compounds in a fuel stream for a molten carbonate fuel cell can be about 90 vol% or less, such as about 75 vol% or less, or about 60 vol% or less, or about 50 vol% or less, or about 40 vol% or less, or about 35 vol% or less.

[00138] Yet other examples of potential sources for an anode input stream can correspond to refinery and/or other industrial process output streams. For example, coking is a common process in many refineries for converting heavier compounds to lower boiling ranges. Coking typically produces an off-gas containing a variety of compounds that are gases at room temperature, including CO and various C1 – C4 hydrocarbons. This off-gas can be used as at least a portion of an anode input stream. Other refinery off-gas streams can additionally or alternately be suitable for inclusion in an anode input stream, such as light ends (C1 – C4) generated during cracking or other refinery processes. Still other suitable refinery streams can additionally or alternately

include refinery streams containing CO or CO₂ that also contain H₂ and/or reformable fuel compounds.

[00139] Still other potential sources for an anode input can additionally or alternately include streams with increased water content. For example, an ethanol output stream from an ethanol plant (or another type of fermentation process) can include a substantial portion of H₂O prior to final distillation. Such H₂O can typically cause only minimal impact on the operation of a fuel cell. Thus, a fermentation mixture of alcohol (or other fermentation product) and water can be used as at least a portion of an anode input stream.

[00140] Biogas, or digester gas, is another additional or alternate potential source for an anode input. Biogas may primarily comprise methane and CO₂ and is typically produced by the breakdown or digestion of organic matter. Anaerobic bacteria may be used to digest the organic matter and produce the biogas. Impurities, such as sulfur-containing compounds, may be removed from the biogas prior to use as an anode input.

[00141] The output stream from an MCFC anode can include H₂O, CO₂, CO, and H₂. Optionally, the anode output stream could also have unreacted fuel (such as H₂ or CH₄) or inert compounds in the feed as additional output components. Instead of using this output stream as a fuel source to provide heat for a reforming reaction or as a combustion fuel for heating the cell, one or more separations can be performed on the anode output stream to separate the CO₂ from the components with potential value as inputs to another process, such as H₂ or CO. The H₂ and/or CO can be used as a syngas for chemical synthesis, as a source of hydrogen for chemical reaction, and/or as a fuel with reduced greenhouse gas emissions.

[00142] In various aspects, the composition of the output stream from the anode can be impacted by several factors. Factors that can influence the anode output composition can include the composition of the input stream to the anode, the amount of current generated by the fuel cell, and/or the temperature at the exit of the anode. The temperature of at the anode exit can be relevant due to the equilibrium nature of the water gas shift reaction. In a typical anode, at least one of the plates forming the wall of the anode can be suitable for catalyzing the water gas shift reaction. As a result, if a) the composition of the anode input stream is known, b) the extent of reforming of reformable fuel in the anode input stream is known, and c) the amount of carbonate

transported from the cathode to anode (corresponding to the amount of electrical current generated) is known, the composition of the anode output can be determined based on the equilibrium constant for the water gas shift reaction.

$$K_{\text{eq}} = [\text{CO}_2] [\text{H}_2] / [\text{CO}] [\text{H}_2\text{O}]$$

[00143] In the above equation, K_{eq} is the equilibrium constant for the reaction at a given temperature and pressure, and $[X]$ is the partial pressure of component X. Based on the water gas shift reaction, it can be noted that an increased CO_2 concentration in the anode input can tend to result in additional CO formation (at the expense of H_2) while an increased H_2O concentration can tend to result in additional H_2 formation (at the expense of CO).

[00144] To determine the composition at the anode output, the composition of the anode input can be used as a starting point. This composition can then be modified to reflect the extent of reforming of any reformable fuels that can occur within the anode. Such reforming can reduce the hydrocarbon content of the anode input in exchange for increased hydrogen and CO_2 . Next, based on the amount of electrical current generated, the amount of H_2 in the anode input can be reduced in exchange for additional H_2O and CO_2 . This composition can then be adjusted based on the equilibrium constant for the water gas shift reaction to determine the exit concentrations for H_2 , CO, CO_2 , and H_2O .

[00145] Table 1 shows the anode exhaust composition at different fuel utilizations for a typical type of fuel. The anode exhaust composition can reflect the combined result of the anode reforming reaction, water gas shift reaction, and the anode oxidation reaction. The output composition values in Table 1 were calculated by assuming an anode input composition with an about 2 to 1 ratio of steam (H_2O) to carbon (reformable fuel). The reformable fuel was assumed to be methane, which was assumed to be 100% reformed to hydrogen. The initial CO_2 and H_2 concentrations in the anode input were assumed to be negligible, while the input N_2 concentration was about 0.5%. The fuel utilization U_f (as defined herein) was allowed to vary from about 35% to about 70% as shown in the table. The exit temperature for the fuel cell anode was assumed to be about 650°C for purposes of determining the correct value for the equilibrium constant.

TABLE 1 - Anode Exhaust Composition

Uf	%	35%	40%	45%	50%	55%	60%	65%	70%
Anode Exhaust Composition									
H₂O	%, wet	32.5%	34.1%	35.5%	36.7%	37.8%	38.9%	39.8%	40.5%
CO₂	%, wet	26.7%	29.4%	32.0%	34.5%	36.9%	39.3%	41.5%	43.8%
H₂	%, wet	29.4%	26.0%	22.9%	20.0%	17.3%	14.8%	12.5%	10.4%
CO	%, wet	10.8%	10.0%	9.2%	8.4%	7.5%	6.7%	5.8%	4.9%
N₂	%, wet	0.5%	0.5%	0.5%	0.4%	0.4%	0.4%	0.4%	0.4%
CO₂	%, dry	39.6%	44.6%	49.6%	54.5%	59.4%	64.2%	69.0%	73.7%
H₂	%, dry	43.6%	39.4%	35.4%	31.5%	27.8%	24.2%	20.7%	17.5%
CO	%, dry	16.1%	15.2%	14.3%	13.2%	12.1%	10.9%	9.7%	8.2%
N₂	%, dry	0.7%	0.7%	0.7%	0.7%	0.7%	0.7%	0.7%	0.7%
H₂/CO		2.7	2.6	2.5	2.4	2.3	2.2	2.1	2.1
(H₂-CO₂)/ (CO+CO₂)		0.07	-0.09	-0.22	-0.34	-0.44	-0.53	-0.61	-0.69

[00146] Table 1 shows anode output compositions for a particular set of conditions and anode input composition. More generally, in various aspects the anode output can include about 10 vol% to about 50 vol% H₂O. The amount of H₂O can vary greatly, as H₂O in the anode can be produced by the anode oxidation reaction. If an excess of H₂O beyond what is needed for reforming is introduced into the anode, the excess H₂O can typically pass through largely unreacted, with the exception of H₂O consumed (or generated) due to fuel reforming and the water gas shift reaction. The CO₂ concentration in the anode output can also vary widely, such as from about 20 vol% to about 50 vol% CO₂. The amount of CO₂ can be influenced by both the amount of electrical current generated as well as the amount of CO₂ in the anode input flow. The amount of H₂ in the anode output can additionally or alternately be from about 10 vol% H₂ to about 50 vol% H₂, depending on the fuel utilization in the anode. At the anode output, the amount of CO can be from about 5 vol% to about 20 vol%. It is noted that the amount of CO relative to the amount of H₂ in the anode output for a given fuel cell can be determined in part by the equilibrium constant for the water gas shift reaction at the temperature and pressure present in the fuel cell. The anode output can further additionally or alternately include 5 vol% or less of various other components, such as N₂, CH₄ (or other unreacted carbon-containing fuels), and/or other components.

[00147] Optionally, one or more water gas shift reaction stages can be included after the anode output to convert CO and H₂O in the anode output into CO₂ and H₂, if

desired. The amount of H₂ present in the anode output can be increased, for example, by using a water gas shift reactor at lower temperature to convert H₂O and CO present in the anode output into H₂ and CO₂. Alternatively, the temperature can be raised and the water-gas shift reaction can be reversed, producing more CO and H₂O from H₂ and CO₂. Water is an expected output of the reaction occurring at the anode, so the anode output can typically have an excess of H₂O relative to the amount of CO present in the anode output. Alternatively, H₂O can be added to the stream after the anode exit but before the water gas shift reaction. CO can be present in the anode output due to incomplete carbon conversion during reforming and/or due to the equilibrium balancing reactions between H₂O, CO, H₂, and CO₂ (i.e., the water-gas shift equilibrium) under either reforming conditions or the conditions present during the anode reaction. A water gas shift reactor can be operated under conditions to drive the equilibrium further in the direction of forming CO₂ and H₂ at the expense of CO and H₂O. Higher temperatures can tend to favor the formation of CO and H₂O. Thus, one option for operating the water gas shift reactor can be to expose the anode output stream to a suitable catalyst, such as a catalyst including iron oxide, zinc oxide, copper on zinc oxide, or the like, at a suitable temperature, e.g., between about 190°C to about 210°C. Optionally, the water-gas shift reactor can include two stages for reducing the CO concentration in an anode output stream, with a first higher temperature stage operated at a temperature from at least about 300°C to about 375°C and a second lower temperature stage operated at a temperature of about 225°C or less, such as from about 180°C to about 210°C. In addition to increasing the amount of H₂ present in the anode output, the water-gas shift reaction can additionally or alternately increase the amount of CO₂ at the expense of CO. This can exchange difficult-to-remove carbon monoxide (CO) for carbon dioxide, which can be more readily removed by condensation (e.g., cryogenic removal), chemical reaction (such as amine removal), and/or other CO₂ removal methods. Additionally or alternately, it may be desirable to increase the CO content present in the anode exhaust in order to achieve a desired ratio of H₂ to CO.

[00148] After passing through the optional water gas shift reaction stage, the anode output can be passed through one or more separation stages for removal of water and/or CO₂ from the anode output stream. For example, one or more CO₂ output streams can be formed by performing CO₂ separation on the anode output using one or more

methods individually or in combination. Such methods can be used to generate CO₂ output stream(s) having a CO₂ content of 90 vol% or greater, such as at least 95% vol% CO₂, or at least 98 vol% CO₂. Such methods can recover about at least about 70% of the CO₂ content of the anode output, such as at least about 80% of the CO₂ content of the anode output, or at least about 90%. Alternatively, in some aspects it may be desirable to recover only a portion of the CO₂ within an anode output stream, with the recovered portion of CO₂ being about 33% to about 90% of the CO₂ in the anode output, such as at least about 40%, or at least about 50%. For example, it may be desirable to retain some CO₂ in the anode output flow so that a desired composition can be achieved in a subsequent water gas shift stage. Suitable separation methods may comprise use of a physical solvent (e.g., Selexol™ or Rectisol™); amines or other bases (e.g., MEA or MDEA); refrigeration (e.g., cryogenic separation); pressure swing adsorption; vacuum swing adsorption; and combinations thereof. A cryogenic CO₂ separator can be an example of a suitable separator. As the anode output is cooled, the majority of the water in the anode output can be separated out as a condensed (liquid) phase. Further cooling and/or pressurizing of the water-depleted anode output flow can then separate high purity CO₂, as the other remaining components in the anode output flow (such as H₂, N₂, CH₄) do not tend to readily form condensed phases. A cryogenic CO₂ separator can recover between about 33% and about 90% of the CO₂ present in a flow, depending on the operating conditions.

[00149] Removal of water from the anode exhaust to form one or more water output streams can also be beneficial, whether prior to, during, or after performing CO₂ separation. The amount of water in the anode output can vary depending on operating conditions selected. For example, the steam-to-carbon ratio established at the anode inlet can affect the water content in the anode exhaust, with high steam-to-carbon ratios typically resulting in a large amount of water that can pass through the anode unreacted and/or reacted only due to the water gas shift equilibrium in the anode. Depending on the aspect, the water content in the anode exhaust can correspond to up to about 30% or more of the volume in the anode exhaust. Additionally or alternately, the water content can be about 80% or less of the volume of the anode exhaust. While such water can be removed by compression and/or cooling with resulting condensation, the removal of this water can require extra compressor power and/or heat exchange surface area and

excessive cooling water. One beneficial way to remove a portion of this excess water can be based on use of an adsorbent bed that can capture the humidity from the moist anode effluent and can then be 'regenerated' using dry anode feed gas, in order to provide additional water for the anode feed. HVAC-style (heating, ventilation, and air conditioning) adsorption wheels design can be applicable, because anode exhaust and inlet can be similar in pressure, and minor leakage from one stream to the other can have minimal impact on the overall process. In embodiments where CO₂ removal is performed using a cryogenic process, removal of water prior to or during CO₂ removal may be desirable, including removal by triethyleneglycol (TEG) system and/or desiccants. By contrast, if an amine wash is used for CO₂ removal, water can be removed from the anode exhaust downstream from the CO₂ removal stage.

[00150] Alternately or in addition to a CO₂ output stream and/or a water output stream, the anode output can be used to form one or more product streams containing a desired chemical or fuel product. Such a product stream or streams can correspond to a syngas stream, a hydrogen stream, or both syngas product and hydrogen product streams. For example, a hydrogen product stream containing at least about 70 vol% H₂, such as at least about 90 vol% H₂ or at least about 95 vol% H₂, can be formed. Additionally or alternately, a syngas stream containing at least about 70 vol% of H₂ and CO combined, such as at least about 90 vol% of H₂ and CO can be formed. The one or more product streams can have a gas volume corresponding to at least about 75% of the combined H₂ and CO gas volumes in the anode output, such as at least about 85% or at least about 90% of the combined H₂ and CO gas volumes. It is noted that the relative amounts of H₂ and CO in the products streams may differ from the H₂ to CO ratio in the anode output based on use of water gas shift reaction stages to convert between the products.

[00151] In some aspects, it can be desirable to remove or separate a portion of the H₂ present in the anode output. For example, in some aspects the H₂ to CO ratio in the anode exhaust can be at least about 3.0 : 1. By contrast, processes that make use of syngas, such as Fischer-Tropsch synthesis, may consume H₂ and CO in a different ratio, such as a ratio that is closer to 2 : 1. One alternative can be to use a water gas shift reaction to modify the content of the anode output to have an H₂ to CO ratio closer to a desired syngas composition. Another alternative can be to use a membrane separation to remove a portion of the H₂ present in the anode output to achieve a

desired ratio of H₂ and CO, or still alternately to use a combination of membrane separation and water gas shift reactions. One advantage of using a membrane separation to remove only a portion of the H₂ in the anode output can be that the desired separation can be performed under relatively mild conditions. Since one goal can be to produce a retentate that still has a substantial H₂ content, a permeate of high purity hydrogen can be generated by membrane separation without requiring severe conditions. For example, rather than having a pressure on the permeate side of the membrane of about 100 kPaa or less (such as ambient pressure), the permeate side can be at an elevated pressure relative to ambient while still having sufficient driving force to perform the membrane separation. Additionally or alternately, a sweep gas such as methane can be used to provide a driving force for the membrane separation. This can reduce the purity of the H₂ permeate stream, but may be advantageous, depending on the desired use for the permeate stream.

[00152] In various aspects of the invention, at least a portion of the anode exhaust stream (preferably after separation of CO₂ and/or H₂O) can be used as a feed for a process external to the fuel cell and associated reforming stages. In various aspects, the anode exhaust can have a ratio of H₂ to CO of about 1.5 : 1 to about 10 : 1, such as at least about 3.0 : 1, or at least about 4.0 : 1, or at least about 5.0 : 1. A syngas stream can be generated or withdrawn from the anode exhaust. The anode exhaust gas, optionally after separation of CO₂ and/or H₂O, and optionally after performing a water gas shift reaction and/or a membrane separation to remove excess hydrogen, can correspond to a stream containing substantial portions of H₂ and/or CO. For a stream with a relatively low content of CO, such as a stream where the ratio of H₂ to CO is at least about 3 : 1, the anode exhaust can be suitable for use as an H₂ feed. Examples of processes that could benefit from an H₂ feed can include, but are not limited to, refinery processes, an ammonia synthesis plant, or a turbine in a (different) power generation system, or combinations thereof. Depending on the application, still lower CO₂ contents can be desirable. For a stream with an H₂-to-CO ratio of less than about 2.2 to 1 and greater than about 1.9 to 1, the stream can be suitable for use as a syngas feed. Examples of processes that could benefit from a syngas feed can include, but are not limited to, a gas-to-liquids plant (such as a plant using a Fischer-Tropsch process with a non-shifting catalyst) and/or a methanol synthesis plant. The amount of the anode

exhaust used as a feed for an external process can be any convenient amount. Optionally, when a portion of the anode exhaust is used as a feed for an external process, a second portion of the anode exhaust can be recycled to the anode input and/or recycled to the combustion zone for a combustion-powered generator.

[00153] The input streams useful for different types of Fischer-Tropsch synthesis processes can provide an example of the different types of product streams that may be desirable to generate from the anode output. For a Fischer-Tropsch synthesis reaction system that uses a shifting catalyst, such as an iron-based catalyst, the desired input stream to the reaction system can include CO₂ in addition to H₂ and CO. If a sufficient amount of CO₂ is not present in the input stream, a Fischer-Tropsch catalyst with water gas shift activity can consume CO in order to generate additional CO₂, resulting in a syngas that can be deficient in CO. For integration of such a Fischer-Tropsch process with an MCFC fuel cell, the separation stages for the anode output can be operated to retain a desired amount of CO₂ (and optionally H₂O) in the syngas product. By contrast, for a Fischer-Tropsch catalyst based on a non-shifting catalyst, any CO₂ present in a product stream could serve as an inert component in the Fischer-Tropsch reaction system.

[00154] In an aspect where the membrane is swept with a sweep gas such as a methane sweep gas, the methane sweep gas can correspond to a methane stream used as the anode fuel or in a different low pressure process, such as a boiler, furnace, gas turbine, or other fuel-consuming device. In such an aspect, low levels of CO₂ permeation across the membrane can have minimal consequence. Such CO₂ that may permeate across the membrane can have a minimal impact on the reactions within the anode, and such CO₂ can remain contained in the anode product. Therefore, the CO₂ (if any) lost across the membrane due to permeation does not need to be transferred again across the MCFC electrolyte. This can significantly reduce the separation selectivity requirement for the hydrogen permeation membrane. This can allow, for example, use of a higher-permeability membrane having a lower selectivity, which can enable use of a lower pressure and/or reduced membrane surface area. In such an aspect of the invention, the volume of the sweep gas can be a large multiple of the volume of hydrogen in the anode exhaust, which can allow the effective hydrogen concentration on the permeate side to be maintained close to zero. The hydrogen thus separated can be incorporated

into the turbine-fed methane where it can enhance the turbine combustion characteristics, as described above.

[00155] It is noted that excess H₂ produced in the anode can represent a fuel where the greenhouse gases have already been separated. Any CO₂ in the anode output can be readily separated from the anode output, such as by using an amine wash, a cryogenic CO₂ separator, and/or a pressure or vacuum swing absorption process. Several of the components of the anode output (H₂, CO, CH₄) are not easily removed, while CO₂ and H₂O can usually be readily removed. Depending on the embodiment, at least about 90 vol% of the CO₂ in the anode output can be separated out to form a relatively high purity CO₂ output stream. Thus, any CO₂ generated in the anode can be efficiently separated out to form a high purity CO₂ output stream. After separation, the remaining portion of the anode output can correspond primarily to components with chemical and/or fuel value, as well as reduced amounts of CO₂ and/or H₂O. Since a substantial portion of the CO₂ generated by the original fuel (prior to reforming) can have been separated out, the amount of CO₂ generated by subsequent burning of the remaining portion of the anode output can be reduced. In particular, to the degree that the fuel in the remaining portion of the anode output is H₂, no additional greenhouse gases can typically be formed by burning of this fuel.

[00156] The anode exhaust can be subjected to a variety of gas processing options, including water-gas shift and separation of the components from each other. Two general anode processing schemes are shown in FIGS. 6 and 7.

[00157] FIG. 6 schematically shows an example of a reaction system for operating a fuel cell array of molten carbonate fuel cells in conjunction with a chemical synthesis process. In FIG. 6, a fuel stream 605 is provided to a reforming stage (or stages) 610 associated with the anode 627 of a fuel cell 620, such as a fuel cell that is part of a fuel cell stack in a fuel cell array. The reforming stage 610 associated with fuel cell 620 can be internal to a fuel cell assembly. In some optional aspects, an external reforming stage (not shown) can also be used to reform a portion of the reformable fuel in an input stream prior to passing the input stream into a fuel cell assembly. Fuel stream 605 can preferably include a reformable fuel, such as methane, other hydrocarbons, and/or other hydrocarbon-like compounds such as organic compounds containing carbon-hydrogen bonds. Fuel stream 605 can also optionally contain H₂ and/or CO, such as H₂

and/or CO provided by optional anode recycle stream 685. It is noted that anode recycle stream 685 is optional, and that in many aspects no recycle stream is provided from the anode exhaust 625 back to anode 627, either directly or indirectly via combination with fuel stream 605 or reformed fuel stream 615. After reforming, the reformed fuel stream 615 can be passed into anode 627 of fuel cell 620. A CO₂ and O₂-containing stream 619 can also be passed into cathode 629. A flow of carbonate ions 622, CO₃²⁻, from the cathode portion 629 of the fuel cell can provide the remaining reactant needed for the anode fuel cell reactions. Based on the reactions in the anode 627, the resulting anode exhaust 625 can include H₂O, CO₂, one or more components corresponding to incompletely reacted fuel (H₂, CO, CH₄, or other components corresponding to a reformable fuel), and optionally one or more additional nonreactive components, such as N₂ and/or other contaminants that are part of fuel stream 605. The anode exhaust 625 can then be passed into one or more separation stages. For example, a CO₂ removal stage 640 can correspond to a cryogenic CO₂ removal system, an amine wash stage for removal of acid gases such as CO₂, or another suitable type of CO₂ separation stage for separating a CO₂ output stream 643 from the anode exhaust. Optionally, the anode exhaust can first be passed through a water gas shift reactor 630 to convert any CO present in the anode exhaust (along with some H₂O) into CO₂ and H₂ in an optionally water gas shifted anode exhaust 635. Depending on the nature of the CO₂ removal stage, a water condensation or removal stage 650 may be desirable to remove a water output stream 653 from the anode exhaust. Though shown in FIG. 6 after the CO₂ separation stage 640, it may optionally be located before the CO₂ separation stage 640 instead. Additionally, an optional membrane separation stage 660 for separation of H₂ can be used to generate a high purity permeate stream 663 of H₂. The resulting retentate stream 666 can then be used as an input to a chemical synthesis process. Stream 666 could additionally or alternately be shifted in a second water-gas shift reactor 631 to adjust the H₂, CO, and CO₂ content to a different ratio, producing an output stream 668 for further use in a chemical synthesis process. In FIG. 6, anode recycle stream 685 is shown as being withdrawn from the retentate stream 666, but the anode recycle stream 685 could additionally or alternately be withdrawn from other convenient locations in or between the various separation stages. The separation stages and shift reactor(s) could additionally or alternately be configured in different orders,

and/or in a parallel configuration. Finally, a stream with a reduced content of CO₂ 639 can be generated as an output from cathode 629. For the sake of simplicity, various stages of compression and heat addition/removal that might be useful in the process, as well as steam addition or removal, are not shown.

[00158] As noted above, the various types of separations performed on the anode exhaust can be performed in any convenient order. FIG. 7 shows an example of an alternative order for performing separations on an anode exhaust. In FIG. 7, anode exhaust 625 can be initially passed into separation stage 760 for removing a portion 763 of the hydrogen content from the anode exhaust 625. This can allow, for example, reduction of the H₂ content of the anode exhaust to provide a retentate 766 with a ratio of H₂ to CO closer to 2 : 1. The ratio of H₂ to CO can then be further adjusted to achieve a desired value in a water gas shift stage 730. The water gas shifted output 735 can then pass through CO₂ separation stage 740 and water removal stage 750 to produce an output stream 775 suitable for use as an input to a desired chemical synthesis process. Optionally, output stream 775 could be exposed to an additional water gas shift stage (not shown). A portion of output stream 775 can optionally be recycled (not shown) to the anode input. Of course, still other combinations and sequencing of separation stages can be used to generate a stream based on the anode output that has a desired composition. For the sake of simplicity, various stages of compression and heat addition/removal that might be useful in the process, as well as steam addition or removal, are not shown.

Cathode Inputs and Outputs

[00159] Conventionally, a molten carbonate fuel cell can be operated based on drawing a desired load while consuming some portion of the fuel in the fuel stream delivered to the anode. The voltage of the fuel cell can then be determined by the load, fuel input to the anode, air and CO₂ provided to the cathode, and the internal resistances of the fuel cell. The CO₂ to the cathode can be conventionally provided in part by using the anode exhaust as at least a part of the cathode input stream. By contrast, the present invention can use separate/different sources for the anode input and cathode input. By removing any direct link between the composition of the anode input flow and the cathode input flow, additional options become available for operating the fuel cell, such as to

generate excess synthesis gas, to improve capture of carbon dioxide, and/or to improve the total efficiency (electrical plus chemical power) of the fuel cell, among others.

[00160] In a molten carbonate fuel cell, the transport of carbonate ions across the electrolyte in the fuel cell can provide a method for transporting CO₂ from a first flow path to a second flow path, where the transport method can allow transport from a lower concentration (the cathode) to a higher concentration (the anode), which can thus facilitate capture of CO₂. Part of the selectivity of the fuel cell for CO₂ separation can be based on the electrochemical reactions allowing the cell to generate electrical power. For nonreactive species (such as N₂) that effectively do not participate in the electrochemical reactions within the fuel cell, there can be an insignificant amount of reaction and transport from cathode to anode. By contrast, the potential (voltage) difference between the cathode and anode can provide a strong driving force for transport of carbonate ions across the fuel cell. As a result, the transport of carbonate ions in the molten carbonate fuel cell can allow CO₂ to be transported from the cathode (lower CO₂ concentration) to the anode (higher CO₂ concentration) with relatively high selectivity. However, a challenge in using molten carbonate fuel cells for carbon dioxide removal can be that the fuel cells have limited ability to remove carbon dioxide from relatively dilute cathode feeds. The voltage and/or power generated by a carbonate fuel cell can start to drop rapidly as the CO₂ concentration falls below about 2.0 vol%. As the CO₂ concentration drops further, e.g., to below about 1.0 vol%, at some point the voltage across the fuel cell can become low enough that little or no further transport of carbonate may occur and the fuel cell ceases to function. Thus, at least some CO₂ is likely to be present in the exhaust gas from the cathode stage of a fuel cell under commercially viable operating conditions.

[00161] The amount of carbon dioxide delivered to the fuel cell cathode(s) can be determined based on the CO₂ content of a source for the cathode inlet. One example of a suitable CO₂-containing stream for use as a cathode input flow can be an output or exhaust flow from a combustion source. Examples of combustion sources include, but are not limited to, sources based on combustion of natural gas, combustion of coal, and/or combustion of other hydrocarbon-type fuels (including biologically derived fuels). Additional or alternate sources can include other types of boilers, fired heaters, furnaces, and/or other types of devices that burn carbon-containing fuels in order to

heat another substance (such as water or air). To a first approximation, the CO₂ content of the output flow from a combustion source can be a minor portion of the flow. Even for a higher CO₂ content exhaust flow, such as the output from a coal-fired combustion source, the CO₂ content from most commercial coal-fired power plants can be about 15 vol% or less. More generally, the CO₂ content of an output or exhaust flow from a combustion source can be at least about 1.5 vol%, or at least about 1.6 vol%, or at least about 1.7 vol%, or at least about 1.8 vol% , or at least about 1.9 vol%, or at least greater 2 vol%, or at least about 4 vol%, or at least about 5 vol%, or at least about 6 vol%, or at least about 8 vol%. Additionally or alternately, the CO₂ content of an output or exhaust flow from a combustion source can be about 20 vol% or less, such as about 15 vol% or less, or about 12 vol% or less, or about 10 vol % or less, or about 9 vol % or less, or about 8 vol % or less, or about 7 vol% or less, or about 6.5 vol% or less, or about 6 vol% or less, or about 5.5 vol% or less, or about 5 vol% or less, or about 4.5 vol% or less. The concentrations given above are on a dry basis. It is noted that the lower CO₂ content values can be present in the exhaust from some natural gas or methane combustion sources, such as generators that are part of a power generation system that may or may not include an exhaust gas recycle loop.

[00162] Other potential sources for a cathode input stream can additionally or alternately include sources of bio-produced CO₂. This can include, for example, CO₂ generated during processing of bio-derived compounds, such as CO₂ generated during ethanol production. An additional or alternate example can include CO₂ generated by combustion of a bio-produced fuel, such as combustion of lignocellulose. Still other additional or alternate potential CO₂ sources can correspond to output or exhaust streams from various industrial processes, such as CO₂-containing streams generated by plants for manufacture of steel, cement, and/or paper.

[00163] Yet another additional or alternate potential source of CO₂ can be CO₂-containing streams from a fuel cell. The CO₂-containing stream from a fuel cell can correspond to a cathode output stream from a different fuel cell, an anode output stream from a different fuel cell, a recycle stream from the cathode output to the cathode input of a fuel cell, and/or a recycle stream from an anode output to a cathode input of a fuel cell. For example, an MCFC operated in standalone mode under conventional conditions can generate a cathode exhaust with a CO₂ concentration of at least about 5

vol%. Such a CO₂-containing cathode exhaust could be used as a cathode input for an MCFC operated according to an aspect of the invention. More generally, other types of fuel cells that generate a CO₂ output from the cathode exhaust can additionally or alternately be used, as well as other types of CO₂-containing streams not generated by a “combustion” reaction and/or by a combustion-powered generator. Optionally but preferably, a CO₂-containing stream from another fuel cell can be from another molten carbonate fuel cell. For example, for molten carbonate fuel cells connected in series with respect to the cathodes, the output from the cathode for a first molten carbonate fuel cell can be used as the input to the cathode for a second molten carbonate fuel cell.

[00164] For various types of CO₂-containing streams from sources other than combustion sources, the CO₂ content of the stream can vary widely. The CO₂ content of an input stream to a cathode can contain at least about 2 vol% of CO₂, such as at least about 4 vol%, or at least about 5 vol%, or at least about 6 vol%, or at least about 8 vol%. Additionally or alternately, the CO₂ content of an input stream to a cathode can be about 30 vol% or less, such as about 25 vol% or less, or about 20 vol% or less, or about 15 vol% or less, or about 10 vol% or less, or about 8 vol% or less, or about 6 vol% or less, or about 4 vol% or less. For some still higher CO₂ content streams, the CO₂ content can be greater than about 30 vol%, such as a stream substantially composed of CO₂ with only incidental amounts of other compounds. As an example, a gas-fired turbine without exhaust gas recycle can produce an exhaust stream with a CO₂ content of approximately 4.2 vol%. With EGR, a gas-fired turbine can produce an exhaust stream with a CO₂ content of about 6-8 vol%. Stoichiometric combustion of methane can produce an exhaust stream with a CO₂ content of about 11 vol%. Combustion of coal can produce an exhaust stream with a CO₂ content of about 15–20 vol%. Fired heaters using refinery off-gas can produce an exhaust stream with a CO₂ content of about 12–15 vol%. A gas turbine operated on a low BTU gas without any EGR can produce an exhaust stream with a CO₂ content of ~12 vol%.

[00165] In addition to CO₂, a cathode input stream must include O₂ to provide the components necessary for the cathode reaction. Some cathode input streams can be based on having air as a component. For example, a combustion exhaust stream can be formed by combusting a hydrocarbon fuel in the presence of air. Such a combustion exhaust stream, or another type of cathode input stream having an oxygen content

based on inclusion of air, can have an oxygen content of about 20 vol% or less, such as about 15 vol% or less, or about 10 vol% or less. Additionally or alternately, the oxygen content of the cathode input stream can be at least about 4 vol%, such as at least about 6 vol%, or at least about 8 vol%. More generally, a cathode input stream can have a suitable content of oxygen for performing the cathode reaction. In some aspects, this can correspond to an oxygen content of about 5 vol% to about 15 vol%, such as from about 7 vol% to about 9 vol%. For many types of cathode input streams, the combined amount of CO₂ and O₂ can correspond to less than about 21 vol% of the input stream, such as less than about 15 vol% of the stream or less than about 10 vol% of the stream. An air stream containing oxygen can be combined with a CO₂ source that has low oxygen content. For example, the exhaust stream generated by burning coal may include a low oxygen content that can be mixed with air to form a cathode inlet stream.

[00166] In addition to CO₂ and O₂, a cathode input stream can also be composed of inert/non-reactive species such as N₂, H₂O, and other typical oxidant (air) components. For example, for a cathode input derived from an exhaust from a combustion reaction, if air is used as part of the oxidant source for the combustion reaction, the exhaust gas can include typical components of air such as N₂, H₂O, and other compounds in minor amounts that are present in air. Depending on the nature of the fuel source for the combustion reaction, additional species present after combustion based on the fuel source may include one or more of H₂O, oxides of nitrogen (NO_x) and/or sulfur (SO_x), and other compounds either present in the fuel and/or that are partial or complete combustion products of compounds present in the fuel, such as CO. These species may be present in amounts that do not poison the cathode catalyst surfaces though they may reduce the overall cathode activity. Such reductions in performance may be acceptable, or species that interact with the cathode catalyst may be reduced to acceptable levels by known pollutant removal technologies.

[00167] The amount of O₂ present in a cathode input stream (such as an input cathode stream based on a combustion exhaust) can advantageously be sufficient to provide the oxygen needed for the cathode reaction in the fuel cell. Thus, the volume percentage of O₂ can advantageously be at least 0.5 times the amount of CO₂ in the exhaust. Optionally, as necessary, additional air can be added to the cathode input to provide sufficient oxidant for the cathode reaction. When some form of air is used as the

oxidant, the amount of N₂ in the cathode exhaust can be at least about 78 vol%, e.g., at least about 88 vol%, and/or about 95 vol% or less. In some aspects, the cathode input stream can additionally or alternately contain compounds that are generally viewed as contaminants, such as H₂S or NH₃. In other aspects, the cathode input stream can be cleaned to reduce or minimize the content of such contaminants.

[00168] In addition to the reaction to form carbonate ions for transport across the electrolyte, the conditions in the cathode can also be suitable for conversion of nitrogen oxides into nitrate and/or nitrate ions. Hereinafter, only nitrate ions will be referred to for convenience. The resulting nitrate ions can also be transported across the electrolyte for reaction in the anode. NO_x concentrations in a cathode input stream can typically be on the order of ppm, so this nitrate transport reaction can have a minimal impact on the amount of carbonate transported across the electrolyte. However, this method of NO_x removal can be beneficial for cathode input streams based on combustion exhausts from gas turbines, as this can provide a mechanism for reducing NO_x emissions. The conditions in the cathode can additionally or alternately be suitable for conversion of unburned hydrocarbons (in combination with O₂ in the cathode input stream) to typical combustion products, such as CO₂ and H₂O.

[00169] A suitable temperature for operation of an MCFC can be between about 450°C and about 750°C, such as at least about 500°C, e.g., with an inlet temperature of about 550°C and an outlet temperature of about 625°C. Prior to entering the cathode, heat can be added to or removed from the combustion exhaust, if desired, e.g., to provide heat for other processes, such as reforming the fuel input for the anode. For example, if the source for the cathode input stream is a combustion exhaust stream, the combustion exhaust stream may have a temperature greater than a desired temperature for the cathode inlet. In such an aspect, heat can be removed from the combustion exhaust prior to use as the cathode input stream. Alternatively, the combustion exhaust could be at very low temperature, for example after a wet gas scrubber on a coal-fired boiler, in which case the combustion exhaust can be below about 100°C. Alternatively, the combustion exhaust could be from the exhaust of a gas turbine operated in combined cycle mode, in which the gas can be cooled by raising steam to run a steam turbine for additional power generation. In this case, the gas can be below about 50°C. Heat can be added to a combustion exhaust that is cooler than desired.

Fuel Cell Arrangement

[00170] In various aspects, a configuration option for a fuel cell (such as a fuel cell array containing multiple fuel cell stacks) can be to divide the CO₂-containing stream between a plurality of fuel cells. Some types of sources for CO₂-containing streams can generate large volumetric flow rates relative to the capacity of an individual fuel cell. For example, the CO₂-containing output stream from an industrial combustion source can typically correspond to a large flow volume relative to desirable operating conditions for a single MCFC of reasonable size. Instead of processing the entire flow in a single MCFC, the flow can be divided amongst a plurality of MCFC units, usually at least some of which can be in parallel, so that the flow rate in each unit can be within a desired flow range.

[00171] A second configuration option can be to utilize fuel cells in series to successively remove CO₂ from a flow stream. Regardless of the number of initial fuel cells to which a CO₂-containing stream can be distributed to in parallel, each initial fuel cell can be followed by one or more additional cells in series to further remove additional CO₂. If the desired amount of CO₂ in the cathode output is sufficiently low, attempting to remove CO₂ from a cathode input stream down to the desired level in a single fuel cell or fuel cell stage could lead to a low and/or unpredictable voltage output for the fuel cell. Rather than attempting to remove CO₂ to the desired level in a single fuel cell or fuel cell stage, CO₂ can be removed in successive cells until a desired level can be achieved. For example, each cell in a series of fuel cells can be used to remove some percentage (e.g., about 50%) of the CO₂ present in a fuel stream. In such an example, if three fuel cells are used in series, the CO₂ concentration can be reduced (e.g., to about 15% or less of the original amount present, which can correspond to reducing the CO₂ concentration from about 6% to about 1% or less over the course of three fuel cells in series).

[00172] In another configuration, the operating conditions can be selected in early fuel stages in series to provide a desired output voltage while the array of stages can be selected to achieve a desired level of carbon separation. As an example, an array of fuel cells can be used with three fuel cells in series. The first two fuel cells in series can be used to remove CO₂ while maintaining a desired output voltage. The final fuel

cell can then be operated to remove CO₂ to a desired concentration but at a lower voltage.

[00173] In still another configuration, there can be separate connectivity for the anodes and cathodes in a fuel cell array. For example, if the fuel cell array includes fuel cathodes connected in series, the corresponding anodes can be connected in any convenient manner, not necessarily matching up with the same arrangement as their corresponding cathodes, for example. This can include, for instance, connecting the anodes in parallel, so that each anode receives the same type of fuel feed, and/or connecting the anodes in a reverse series, so that the highest fuel concentration in the anodes can correspond to those cathodes having the lowest CO₂ concentration.

[00174] In yet another configuration, the amount of fuel delivered to one or more anode stages and/or the amount of CO₂ delivered to one or more cathode stages can be controlled in order to improve the performance of the fuel cell array. For example, a fuel cell array can have a plurality of cathode stages connected in series. In an array that includes three cathode stages in series, this can mean that the output from a first cathode stage can correspond to the input for a second cathode stage, and the output from the second cathode stage can correspond to the input for a third cathode stage. In this type of configuration, the CO₂ concentration can decrease with each successive cathode stage. To compensate for this reduced CO₂ concentration, additional hydrogen and/or methane can be delivered to the anode stages corresponding to the later cathode stages. The additional hydrogen and/or methane in the anodes corresponding to the later cathode stages can at least partially offset the loss of voltage and/or current caused by the reduced CO₂ concentration, which can increase the voltage and thus net power produced by the fuel cell. In another example, the cathodes in a fuel cell array can be connected partially in series and partially in parallel. In this type of example, instead of passing the entire combustion output into the cathodes in the first cathode stage, at least a portion of the combustion exhaust can be passed into a later cathode stage. This can provide an increased CO₂ content in a later cathode stage. Still other options for using variable feeds to either anode stages or cathode stages can be used if desired.

[00175] The cathode of a fuel cell can correspond to a plurality of cathodes from an array of fuel cells, as previously described. In some aspects, a fuel cell array can be operated to improve or maximize the amount of carbon transferred from the cathode to

the anode. In such aspects, for the cathode output from the final cathode(s) in an array sequence (typically at least including a series arrangement, or else the final cathode(s) and the initial cathode(s) would be the same), the output composition can include about 2.0 vol% or less of CO₂ (e.g., about 1.5 vol% or less or about 1.2 vol% or less) and/or at least about 1.0 vol% of CO₂, such as at least about 1.2 vol% or at least about 1.5 vol%. Due to this limitation, the net efficiency of CO₂ removal when using molten carbonate fuel cells can be dependent on the amount of CO₂ in the cathode input. For cathode input streams with CO₂ contents of greater than about 6 vol%, such as at least about 8%, the limitation on the amount of CO₂ that can be removed is not severe. However, for a combustion reaction using natural gas as a fuel and with excess air, as is typically found in a gas turbine, the amount of CO₂ in the combustion exhaust may only correspond to a CO₂ concentration at the cathode input of less than about 5 vol%. Use of exhaust gas recycle can allow the amount of CO₂ at the cathode input to be increased to at least about 5 vol%, e.g., at least about 6 vol%. If EGR is increased when using natural gas as a fuel to produce a CO₂ concentration beyond about 6 vol%, then the flammability in the combustor can be decreased and the gas turbine may become unstable. However, when H₂ is added to the fuel, the flammability window can be significantly increased, allowing the amount of exhaust gas recycle to be increased further, so that concentrations of CO₂ at the cathode input of at least about 7.5 vol% or at least about 8 vol% can be achieved. As an example, based on a removal limit of about 1.5 vol% at the cathode exhaust, increasing the CO₂ content at the cathode input from about 5.5 vol% to about 7.5 vol% can correspond to a ~10% increase in the amount of CO₂ that can be captured using a fuel cell and transported to the anode loop for eventual CO₂ separation. The amount of O₂ in the cathode output can additionally or alternately be reduced, typically in an amount proportional to the amount of CO₂ removed, which can result in small corresponding increases in the amount(s) of the other (non-cathode-reactive) species at the cathode exit.

[00176] In other aspects, a fuel cell array can be operated to improve or maximize the energy output of the fuel cell, such as the total energy output, the electric energy output, the syngas chemical energy output, or a combination thereof. For example, molten carbonate fuel cells can be operated with an excess of reformable fuel in a variety of situations, such as for generation of a syngas stream for use in chemical synthesis plant

and/or for generation of a high purity hydrogen stream. The syngas stream and/or hydrogen stream can be used as a syngas source, a hydrogen source, as a clean fuel source, and/or for any other convenient application. In such aspects, the amount of CO₂ in the cathode exhaust can be related to the amount of CO₂ in the cathode input stream and the CO₂ utilization at the desired operating conditions for improving or maximizing the fuel cell energy output.

[00177] Additionally or alternately, depending on the operating conditions, an MCFC can lower the CO₂ content of a cathode exhaust stream to about 5.0 vol% or less, e.g., about 4.0 vol% or less, or about 2.0 vol% or less, or about 1.5 vol% or less, or about 1.2 vol% or less. Additionally or alternately, the CO₂ content of the cathode exhaust stream can be at least about 0.9 vol%, such as at least about 1.0 vol%, or at least about 1.2 vol%, or at least about 1.5 vol%.

Molten Carbonate Fuel Cell Operation

[00178] In some aspects, a fuel cell may be operated in a single pass or once-through mode. In single pass mode, reformed products in the anode exhaust are not returned to the anode inlet. Thus, recycling syngas, hydrogen, or some other product from the anode output directly to the anode inlet is not done in single pass operation. More generally, in single pass operation, reformed products in the anode exhaust are also not returned indirectly to the anode inlet, such as by using reformed products to process a fuel stream subsequently introduced into the anode inlet. Optionally, CO₂ from the anode outlet can be recycled to the cathode inlet during operation of an MCFC in single pass mode. More generally, in some alternative aspects, recycling from the anode outlet to the cathode inlet may occur for an MCFC operating in single pass mode. Heat from the anode exhaust or output may additionally or alternately be recycled in a single pass mode. For example, the anode output flow may pass through a heat exchanger that cools the anode output and warms another stream, such as an input stream for the anode and/or the cathode. Recycling heat from anode to the fuel cell is consistent with use in single pass or once-through operation. Optionally but not preferably, constituents of the anode output may be burned to provide heat to the fuel cell during single pass mode.

[00179] FIG. 2 shows a schematic example of the operation of an MCFC for generation of electrical power. In FIG. 2, the anode portion of the fuel cell can receive

fuel and steam (H₂O) as inputs, with outputs of water, CO₂, and optionally excess H₂, CH₄ (or other hydrocarbons), and/or CO. The cathode portion of the fuel cell can receive CO₂ and some oxidant (e.g., air/O₂) as inputs, with an output corresponding to a reduced amount of CO₂ in O₂-depleted oxidant (air). Within the fuel cell, CO₃²⁻ ions formed in the cathode side can be transported across the electrolyte to provide the carbonate ions needed for the reactions occurring at the anode.

[00180] Several reactions can occur within a molten carbonate fuel cell such as the example fuel cell shown in FIG. 2. The reforming reactions can be optional, and can be reduced or eliminated if sufficient H₂ is provided directly to the anode. The following reactions are based on CH₄, but similar reactions can occur when other fuels are used in the fuel cell.

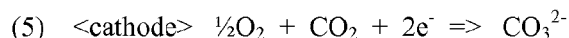
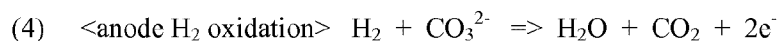
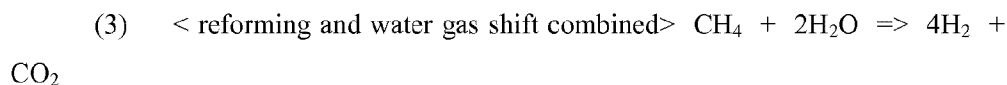
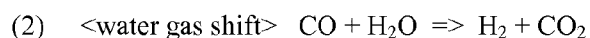
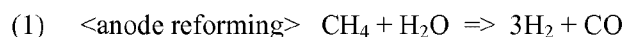

[00181] Reaction (1) represents the basic hydrocarbon reforming reaction to generate H₂ for use in the anode of the fuel cell. The CO formed in reaction (1) can be converted to H₂ by the water-gas shift reaction (2). The combination of reactions (1) and (2) is shown as reaction (3). Reactions (1) and (2) can occur external to the fuel cell, and/or the reforming can be performed internal to the anode.

[00182] Reactions (4) and (5), at the anode and cathode respectively, represent the reactions that can result in electrical power generation within the fuel cell. Reaction (4) combines H₂, either present in the feed or optionally generated by reactions (1) and/or (2), with carbonate ions to form H₂O, CO₂, and electrons to the circuit. Reaction (5) combines O₂, CO₂, and electrons from the circuit to form carbonate ions. The carbonate ions generated by reaction (5) can be transported across the electrolyte of the fuel cell to provide the carbonate ions needed for reaction (4). In combination with the transport of carbonate ions across the electrolyte, a closed current loop can then be formed by providing an electrical connection between the anode and cathode.

[00183] In various embodiments, a goal of operating the fuel cell can be to improve the total efficiency of the fuel cell and/or the total efficiency of the fuel cell plus an integrated chemical synthesis process. This is typically in contrast to conventional operation of a fuel cell, where the goal can be to operate the fuel cell with high electrical efficiency for using the fuel provided to the cell for generation of electrical power. As defined above, total fuel cell efficiency may be determined by dividing the electric output of the fuel cell plus the lower heating value of the fuel cell outputs by the lower heating value of the input components for the fuel cell. In other words, $TFCE = (LHV(el) + LHV(sg\ out))/LHV(in)$, where LHV(in) and LHV(sg out) refer to the LHV of the fuel components (such as H₂, CH₄, and/or CO) delivered to the fuel cell and syngas (H₂, CO and/or CO₂) in the anode outlet streams or flows, respectively. This can provide a measure of the electric energy plus chemical energy generated by the fuel cell and/or the integrated chemical process. It is noted that under this definition of total efficiency, heat energy used within the fuel cell and/or used within the integrated fuel cell / chemical synthesis system can contribute to total efficiency. However, any excess heat exchanged or otherwise withdrawn from the fuel cell or integrated fuel cell / chemical synthesis system is excluded from the definition. Thus, if excess heat from the fuel cell is used, for example, to generate steam for electricity generation by a steam turbine, such excess heat is excluded from the definition of total efficiency.

[00184] Several operational parameters may be manipulated to operate a fuel cell with excess reformable fuel. Some parameters can be similar to those currently recommended for fuel cell operation. In some aspects, the cathode conditions and temperature inputs to the fuel cell can be similar to those recommended in the literature. For example, the desired electrical efficiency and the desired total fuel cell efficiency may be achieved at a range of fuel cell operating temperatures typical for molten carbonate fuel cells. In typical operation, the temperature can increase across the fuel cell.

[00185] In other aspects, the operational parameters of the fuel cell can deviate from typical conditions so that the fuel cell is operated to allow a temperature decrease from the anode inlet to the anode outlet and/or from the cathode inlet to the cathode outlet. For example, the reforming reaction to convert a hydrocarbon into H₂ and CO is an endothermic reaction. If a sufficient amount of reforming is performed in a fuel cell

anode relative to the amount of oxidation of hydrogen to generate electrical current, the net heat balance in the fuel cell can be endothermic. This can cause a temperature drop between the inlets and outlets of a fuel cell. During endothermic operation, the temperature drop in the fuel cell can be controlled so that the electrolyte in the fuel cell remains in a molten state.

[00186] Parameters that can be manipulated in a way so as to differ from those currently recommended can include the amount of fuel provided to the anode, the composition of the fuel provided to the anode, and/or the separation and capture of syngas in the anode output without significant recycling of syngas from the anode exhaust to either the anode input or the cathode input. In some aspects, no recycle of syngas or hydrogen from the anode exhaust to either the anode input or the cathode input can be allowed to occur, either directly or indirectly. In additional or alternative aspects, a limited amount of recycle can occur. In such aspects, the amount of recycle from the anode exhaust to the anode input and/or the cathode input can be less than about 10 vol% of the anode exhaust, such as less than about 5 vol%, or less than about 1 vol%.

[00187] Additionally or alternately, a goal of operating a fuel cell can be to separate CO₂ from the output stream of a combustion reaction or another process that produces a CO₂ output stream, in addition to allowing generation of electric power. In such aspects, the combustion reaction(s) can be used to power one or more generators or turbines, which can provide a majority of the power generated by the combined generator/fuel cell system. Rather than operating the fuel cell to optimize power generation by the fuel cell, the system can instead be operated to improve the capture of carbon dioxide from the combustion-powered generator while reducing or minimizing the number of fuel cells required for capturing the carbon dioxide. Selecting an appropriate configuration for the input and output flows of the fuel cell, as well as selecting appropriate operating conditions for the fuel cell, can allow for a desirable combination of total efficiency and carbon capture.

[00188] In some embodiments, the fuel cells in a fuel cell array can be arranged so that only a single stage of fuel cells (such as fuel cell stacks) can be present. In this type of embodiment, the anode fuel utilization for the single stage can represent the anode fuel utilization for the array. Another option can be that a fuel cell array can contain

multiple stages of anodes and multiple stages of cathodes, with each anode stage having a fuel utilization within the same range, such as each anode stage having a fuel utilization within 10% of a specified value, for example within 5% of a specified value. Still another option can be that each anode stage can have a fuel utilization equal to a specified value or lower than the specified value by less than an amount, such as having each anode stage be not greater than a specified value by 10% or less, for example, by 5% or less. As an illustrative example, a fuel cell array with a plurality of anode stages can have each anode stage be within about 10% of 50% fuel utilization, which would correspond to each anode stage having a fuel utilization between about 40% and about 60%. As another example, a fuel cell array with a plurality of stages can have each anode stage be not greater than 60% anode fuel utilization with the maximum deviation being about 5% less, which would correspond to each anode stage having a fuel utilization between about 55% to about 60%. In still another example, one or more stages of fuel cells in a fuel cell array can be operated at a fuel utilization from about 30% to about 50%, such as operating a plurality of fuel cell stages in the array at a fuel utilization from about 30% to about 50%. More generally, any of the above types of ranges can be paired with any of the anode fuel utilization values specified herein.

[00189] Still another additional or alternate option can include specifying a fuel utilization for less than all of the anode stages. For example, in some aspects of the invention fuel cells/stacks can be arranged at least partially in one or more series arrangements such that anode fuel utilization can be specified for the first anode stage in a series, the second anode stage in a series, the final anode stage in a series, or any other convenient anode stage in a series. As used herein, the “first” stage in a series corresponds to the stage (or set of stages, if the arrangement contains parallel stages as well) to which input is directly fed from the fuel source(s), with later (“second,” “third,” “final,” etc.) stages representing the stages to which the output from one or more previous stages is fed, instead of directly from the respective fuel source(s). In situations where both output from previous stages and input directly from the fuel source(s) are co-fed into a stage, there can be a “first” (set of) stage(s) and a “last” (set of) stage(s), but other stages (“second,” “third,” etc.) can be more tricky among which to establish an order (e.g., in such cases, ordinal order can be determined by concentration levels of one or more components in the composite input feed

composition, such as CO₂ for instance, from highest concentration “first” to lowest concentration “last” with approximately similar compositional distinctions representing the same ordinal level.)

[00190] Yet another additional or alternate option can be to specify the anode fuel utilization corresponding to a particular cathode stage (again, where fuel cells/stacks can be arranged at least partially in one or more series arrangements). As noted above, based on the direction of the flows within the anodes and cathodes, the first cathode stage may not correspond to (be across the same fuel cell membrane from) the first anode stage. Thus, in some aspects of the invention, the anode fuel utilization can be specified for the first cathode stage in a series, the second cathode stage in a series, the final cathode stage in a series, or any other convenient cathode stage in a series.

[00191] Yet still another additional or alternate option can be to specify an overall average of fuel utilization over all fuel cells in a fuel cell array. In various aspects, the overall average of fuel utilization for a fuel cell array can be about 65% or less, for example, about 60% or less, about 55% or less, about 50% or less, or about 45% or less (additionally or alternately, the overall average fuel utilization for a fuel cell array can be at least about 25%, for example at least about 30%, at least about 35%, or at least about 40%). Such an average fuel utilization need not necessarily constrain the fuel utilization in any single stage, so long as the array of fuel cells meets the desired fuel utilization.

Applications for CO₂ Output after Capture

[00192] In various aspects of the invention, the systems and methods described above can allow for production of carbon dioxide as a pressurized fluid. For example, the CO₂ generated from a cryogenic separation stage can initially correspond to a pressurized CO₂ liquid with a purity of at least about 90%, *e.g.*, at least about 95%, at least about 97%, at least about 98%, or at least about 99%. This pressurized CO₂ stream can be used, *e.g.*, for injection into wells in order to further enhance oil or gas recovery such as in secondary oil recovery. When done in proximity to a facility that encompasses a gas turbine, the overall system may benefit from additional synergies in use of electrical/mechanical power and/or through heat integration with the overall system.

[00193] Alternatively, for systems dedicated to an enhanced oil recovery (EOR) application (i.e., not comingled in a pipeline system with tight compositional standards), the CO₂ separation requirements may be substantially relaxed. The EOR application can be sensitive to the presence of O₂, so O₂ can be absent, in some embodiments, from a CO₂ stream intended for use in EOR. However, the EOR application can tend to have a low sensitivity to dissolved CO, H₂, and/or CH₄. Also, pipelines that transport the CO₂ can be sensitive to these impurities. Those dissolved gases can typically have only subtle impacts on the solubilizing ability of CO₂ used for EOR. Injecting gases such as CO, H₂, and/or CH₄ as EOR gases can result in some loss of fuel value recovery, but such gases can be otherwise compatible with EOR applications.

[00194] Additionally or alternately, a potential use for CO₂ as a pressurized liquid can be as a nutrient in biological processes such as algae growth/harvesting. The use of MCFCs for CO₂ separation can ensure that most biologically significant pollutants could be reduced to acceptably low levels, resulting in a CO₂-containing stream having only minor amounts of other “contaminant” gases (such as CO, H₂, N₂, and the like, and combinations thereof) that are unlikely to substantially negatively affect the growth of photosynthetic organisms. This can be in stark contrast to the output streams generated by most industrial sources, which can often contain potentially highly toxic material such as heavy metals.

[00195] In this type of aspect of the invention, the CO₂ stream generated by separation of CO₂ in the anode loop can be used to produce biofuels and/or chemicals, as well as precursors thereof. Further additionally or alternately, CO₂ may be produced as a dense fluid, allowing for much easier pumping and transport across distances, e.g., to large fields of photosynthetic organisms. Conventional emission sources can emit hot gas containing modest amounts of CO₂ (e.g., about 4-15%) mixed with other gases and pollutants. These materials would normally need to be pumped as a dilute gas to an algae pond or biofuel “farm”. By contrast, the MCFC system according to the invention can produce a concentrated CO₂ stream (~60-70% by volume on a dry basis) that can be concentrated further to 95%+ (for example 96%+, 97%+, 98%+, or 99%+) and easily liquefied. This stream can then be transported easily and efficiently over long distances at relatively low cost and effectively distributed over a wide area. In

these embodiments, residual heat from the combustion source/MCFC may be integrated into the overall system as well.

[00196] An alternative embodiment may apply where the CO₂ source/MCFC and biological/ chemical production sites are co-located. In that case, only minimal compression may be necessary (*i.e.*, to provide enough CO₂ pressure to use in the biological production, *e.g.*, from about 15 psig to about 150 psig). Several novel arrangements can be possible in such a case. Secondary reforming may optionally be applied to the anode exhaust to reduce CH₄ content, and water-gas shift may optionally additionally or alternately be present to drive any remaining CO into CO₂ and H₂.

[00197] The components from an anode output stream and/or cathode output stream can be used for a variety of purposes. One option can be to use the anode output as a source of hydrogen, as described above. For an MCFC integrated with or co-located with a refinery, the hydrogen can be used as a hydrogen source for various refinery processes, such as hydroprocessing. Another option can be to additionally or alternately use hydrogen as a fuel source where the CO₂ from combustion has already been “captured.” Such hydrogen can be used in a refinery or other industrial setting as a fuel for a boiler, furnace, and/or fired heater, and/or the hydrogen can be used as a feed for an electric power generator, such as a turbine. Hydrogen from an MCFC fuel cell can further additionally or alternately be used as an input stream for other types of fuel cells that require hydrogen as an input, possibly including vehicles powered by fuel cells. Still another option can be to additionally or alternately use syngas generated as an output from an MCFC fuel cell as a fermentation input.

[00198] Another option can be to additionally or alternately use syngas generated from the anode output. Of course, syngas can be used as a fuel, although a syngas based fuel can still lead to some CO₂ production when burned as fuel. In other aspects, a syngas output stream can be used as an input for a chemical synthesis process. One option can be to additionally or alternately use syngas for a Fischer-Tropsch type process, and/or another process where larger hydrocarbon molecules are formed from the syngas input. Another option can be to additionally or alternately use syngas to form an intermediate product such as methanol. Methanol could be used as the final product, but in other aspects methanol generated from syngas can be used to generate larger compounds, such as gasoline, olefins, aromatics, and/or other products. It is noted that a small

amount of CO₂ can be acceptable in the syngas feed to a methanol synthesis process, and/or to a Fischer-Tropsch process utilizing a shifting catalyst. Hydroformylation is an additional or alternate example of still another synthesis process that can make use of a syngas input.

[00199] It is noted that one variation on use of an MCFC to generate syngas can be to use MCFC fuel cells as part of a system for processing methane and/or natural gas withdrawn by an offshore oil platform or other production system that is a considerable distance from its ultimate market. Instead of attempting to transport the gas phase output from a well, or attempting to store the gas phase product for an extended period, the gas phase output from a well can be used as the input to an MCFC fuel cell array. This can lead to a variety of benefits. First, the electric power generated by the fuel cell array can be used as a power source for the platform. Additionally, the syngas output from the fuel cell array can be used as an input for a Fischer-Tropsch process at the production site. This can allow for formation of liquid hydrocarbon products more easily transported by pipeline, ship, or railcar from the production site to, for example, an on-shore facility or a larger terminal.

[00200] Still other integration options can additionally or alternately include using the cathode output as a source of higher purity, heated nitrogen. The cathode input can often include a large portion of air, which means a substantial portion of nitrogen can be included in the cathode input. The fuel cell can transport CO₂ and O₂ from the cathode across the electrolyte to the anode, and the cathode outlet can have lower concentrations of CO₂ and O₂, and thus a higher concentration of N₂ than found in air. With subsequent removal of the residual O₂ and CO₂, this nitrogen output can be used as an input for production of ammonia or other nitrogen-containing chemicals, such as urea, ammonium nitrate, and/or nitric acid. It is noted that urea synthesis could additionally or alternately use CO₂ separate from the anode output as an input feed.

Integration Example: Applications for Integration with Combustion Turbines

[00201] In some aspects of the invention, a combustion source for generating power and exhausting a CO₂-containing exhaust can be integrated with the operation of molten carbonate fuel cells. An example of a suitable combustion source is a gas turbine. Preferably, the gas turbine can combust natural gas, methane gas, or another hydrocarbon gas in a combined cycle mode integrated with steam generation and heat

recovery for additional efficiency. Modern natural gas combined cycle efficiencies are about 60% for the largest and newest designs. The resulting CO₂-containing exhaust gas stream can be produced at an elevated temperature compatible with the MCFC operation, such as 300°C – 700°C and preferably 500°C – 650°C. The gas source can optionally but preferably be cleaned of contaminants such as sulfur that can poison the MCFC before entering the turbine. Alternatively, the gas source can be a coal-fired generator, wherein the exhaust gas would typically be cleaned post-combustion due to the greater level of contaminants in the exhaust gas. In such an alternative, some heat exchange to/from the gas may be necessary to enable clean-up at lower temperatures. In additional or alternate embodiments, the source of the CO₂-containing exhaust gas can be the output from a boiler, combustor, or other heat source that burns carbon-rich fuels. In other additional or alternate embodiments, the source of the CO₂-containing exhaust gas can be bio-produced CO₂ in combination with other sources.

[00202] For integration with a combustion source, some alternative configurations for processing of a fuel cell anode can be desirable. For example, an alternative configuration can be to recycle at least a portion of the exhaust from a fuel cell anode to the input of a fuel cell anode. The output stream from an MCFC anode can include H₂O, CO₂, optionally CO, and optionally but typically unreacted fuel (such as H₂ or CH₄) as the primary output components. Instead of using this output stream as an external fuel stream and/or an input stream for integration with another process, one or more separations can be performed on the anode output stream in order to separate the CO₂ from the components with potential fuel value, such as H₂ or CO. The components with fuel value can then be recycled to the input of an anode.

[00203] This type of configuration can provide one or more benefits. First, CO₂ can be separated from the anode output, such as by using a cryogenic CO₂ separator. Several of the components of the anode output (H₂, CO, CH₄) are not easily condensable components, while CO₂ and H₂O can be separated individually as condensed phases. Depending on the embodiment, at least about 90 vol% of the CO₂ in the anode output can be separated to form a relatively high purity CO₂ output stream. Alternatively, in some aspects less CO₂ can be removed from the anode output, so that about 50 vol% to about 90 vol% of the CO₂ in the anode output can be separated out, such as about 80 vol% or less or about 70 vol% or less. After separation, the remaining portion of the

anode output can correspond primarily to components with fuel value, as well as reduced amounts of CO₂ and/or H₂O. This portion of the anode output after separation can be recycled for use as part of the anode input, along with additional fuel. In this type of configuration, even though the fuel utilization in a single pass through the MCFC(s) may be low, the unused fuel can be advantageously recycled for another pass through the anode. As a result, the single-pass fuel utilization can be at a reduced level, while avoiding loss (exhaust) of unburned fuel to the environment.

[00204] Additionally or alternatively to recycling a portion of the anode exhaust to the anode input, another configuration option can be to use a portion of the anode exhaust as an input for a combustion reaction for a turbine or other combustion device, such as a boiler, furnace, and/or fired heater. The relative amounts of anode exhaust recycled to the anode input and/or as an input to the combustion device can be any convenient or desirable amount. If the anode exhaust is recycled to only one of the anode input and the combustion device, the amount of recycle can be any convenient amount, such as up to 100% of the portion of the anode exhaust remaining after any separation to remove CO₂ and/or H₂O. When a portion of the anode exhaust is recycled to both the anode input and the combustion device, the total recycled amount by definition can be 100% or less of the remaining portion of anode exhaust. Otherwise, any convenient split of the anode exhaust can be used. In various embodiments of the invention, the amount of recycle to the anode input can be at least about 10% of the anode exhaust remaining after separations, for example at least about 25%, at least about 40%, at least about 50%, at least about 60%, at least about 75%, or at least about 90%. Additionally or alternately in those embodiments, the amount of recycle to the anode input can be about 90% or less of the anode exhaust remaining after separations, for example about 75% or less, about 60% or less, about 50% or less, about 40% or less, about 25% or less, or about 10% or less. Further additionally or alternately, in various embodiments of the invention, the amount of recycle to the combustion device can be at least about 10% of the anode exhaust remaining after separations, for example at least about 25%, at least about 40%, at least about 50%, at least about 60%, at least about 75%, or at least about 90%. Additionally or alternately in those embodiments, the amount of recycle to the combustion device can be about 90% or less of the anode exhaust

remaining after separations, for example about 75% or less, about 60% or less, about 50% or less, about 40% or less, about 25% or less, or about 10% or less.

[00205] In still other alternative aspects of the invention, the fuel for a combustion device can additionally or alternately be a fuel with an elevated quantity of components that are inert and/or otherwise act as a diluent in the fuel. CO₂ and N₂ are examples of components in a natural gas feed that can be relatively inert during a combustion reaction. When the amount of inert components in a fuel feed reaches a sufficient level, the performance of a turbine or other combustion source can be impacted. The impact can be due in part to the ability of the inert components to absorb heat, which can tend to quench the combustion reaction. Examples of fuel feeds with a sufficient level of inert components can include fuel feeds containing at least about 20 vol% CO₂, or fuel feeds containing at least about 40 vol% N₂, or fuel feeds containing combinations of CO₂ and N₂ that have sufficient inert heat capacity to provide similar quenching ability. (It is noted that CO₂ has a greater heat capacity than N₂, and therefore lower concentrations of CO₂ can have a similar impact as higher concentrations of N₂. CO₂ can also participate in the combustion reactions more readily than N₂, and in doing so remove H₂ from the combustion. This consumption of H₂ can have a large impact on the combustion of the fuel, by reducing the flame speed and narrowing the flammability range of the air and fuel mixture.) More generally, for a fuel feed containing inert components that impact the flammability of the fuel feed, the inert components in the fuel feed can be at least about 20 vol%, such as at least about 40 vol%, or at least about 50 vol%, or at least about 60 vol%. Preferably, the amount of inert components in the fuel feed can be about 80 vol% or less.

[00206] When a sufficient amount of inert components are present in a fuel feed, the resulting fuel feed can be outside of the flammability window for the fuel components of the feed. In this type of situation, addition of H₂ from a recycled portion of the anode exhaust to the combustion zone for the generator can expand the flammability window for the combination of fuel feed and H₂, which can allow, for example, a fuel feed containing at least about 20 vol% CO₂ or at least about 40% N₂ (or other combinations of CO₂ and N₂) to be successfully combusted.

[00207] Relative to a total volume of fuel feed and H₂ delivered to a combustion zone, the amount of H₂ for expanding the flammability window can be at least about 5 vol%

of the total volume of fuel feed plus H₂, such as at least about 10 vol%, and/or about 25 vol% or less. Another option for characterizing the amount of H₂ to add to expand the flammability window can be based on the amount of fuel components present in the fuel feed before H₂ addition. Fuel components can correspond to methane, natural gas, other hydrocarbons, and/or other components conventionally viewed as fuel for a combustion-powered turbine or other generator. The amount of H₂ added to the fuel feed can correspond to at least about one third of the volume of fuel components (1 : 3 ratio of H₂ : fuel component) in the fuel feed, such as at least about half of the volume of the fuel components (1 : 2 ratio). Additionally or alternately, the amount of H₂ added to the fuel feed can be roughly equal to the volume of fuel components in the fuel feed (1 : 1 ratio) or less. For example, for a feed containing about 30 vol% CH₄, about 10% N₂, and about 60% CO₂, a sufficient amount of anode exhaust can be added to the fuel feed to achieve about a 1 : 2 ratio of H₂ to CH₄. For an idealized anode exhaust that contained only H₂, addition of H₂ to achieve a 1 : 2 ratio would result in a feed containing about 26 vol% CH₄, 13 vol% H₂, 9 vol% N₂, and 52 vol% CO₂.

Exhaust Gas Recycle

[00208] Aside from providing exhaust gas to a fuel cell array for capture and eventual separation of the CO₂, an additional or alternate potential use for exhaust gas can include recycle back to the combustion reaction to increase the CO₂ content. When hydrogen is available for addition to the combustion reaction, such as hydrogen from the anode exhaust of the fuel cell array, further benefits can be gained from using recycled exhaust gas to increase the CO₂ content within the combustion reaction.

[00209] In various aspects of the invention, the exhaust gas recycle loop of a power generation system can receive a first portion of the exhaust gas from combustion, while the fuel cell array can receive a second portion. The amount of exhaust gas from combustion recycled to the combustion zone of the power generation system can be any convenient amount, such as at least about 15% (by volume), for example at least about 25%, at least about 35%, at least about 45%, or at least about 50%. Additionally or alternately, the amount of combustion exhaust gas recirculated to the combustion zone can be about 65% (by volume) or less, e.g., about 60% or less, about 55% or less, about 50% or less, or about 45% or less.

[00210] In one or more aspects of the invention, a mixture of an oxidant (such as air and/or oxygen-enriched air) and fuel can be combusted and (simultaneously) mixed with a stream of recycled exhaust gas. The stream of recycled exhaust gas, which can generally include products of combustion such as CO₂, can be used as a diluent to control, adjust, or otherwise moderate the temperature of combustion and of the exhaust that can enter the succeeding expander. As a result of using oxygen-enriched air, the recycled exhaust gas can have an increased CO₂ content, thereby allowing the expander to operate at even higher expansion ratios for the same inlet and discharge temperatures, thereby enabling significantly increased power production.

[00211] A gas turbine system can represent one example of a power generation system where recycled exhaust gas can be used to enhance the performance of the system. The gas turbine system can have a first/main compressor coupled to an expander via a shaft. The shaft can be any mechanical, electrical, or other power coupling, thereby allowing a portion of the mechanical energy generated by the expander to drive the main compressor. The gas turbine system can also include a combustion chamber configured to combust a mixture of a fuel and an oxidant. In various aspects of the invention, the fuel can include any suitable hydrocarbon gas/liquid, such as syngas, natural gas, methane, ethane, propane, butane, naphtha diesel, kerosene, aviation fuel, coal derived fuel, bio-fuel, oxygenated hydrocarbon feedstock, or any combinations thereof. The oxidant can, in some embodiments, be derived from a second or inlet compressor fluidly coupled to the combustion chamber and adapted to compress a feed oxidant. In one or more embodiments of the invention, the feed oxidant can include atmospheric air and/or enriched air. When the oxidant includes enriched air alone or a mixture of atmospheric air and enriched air, the enriched air can be compressed by the inlet compressor (in the mixture, either before or after being mixed with the atmospheric air). The enriched air and/or the air-enriched air mixture can have an overall oxygen concentration of at least about 25 volume %, e.g., at least about 30 volume %, at least about 35 volume %, at least about 40 volume %, at least about 45 volume %, or at least about 50 volume %. Additionally or alternately, the enriched air and/or the air-enriched air mixture can have an overall oxygen concentration of about 80 volume % or less, such as about 70 volume % or less.

[00212] The enriched air can be derived from any one or more of several sources. For example, the enriched air can be derived from such separation technologies as membrane separation, pressure swing adsorption, temperature swing adsorption, nitrogen plant-byproduct streams, and/or combinations thereof. The enriched air can additionally or alternately be derived from an air separation unit (ASU), such as a cryogenic ASU, for producing nitrogen for pressure maintenance or other purposes. In certain embodiments of the invention, the reject stream from such an ASU can be rich in oxygen, having an overall oxygen content from about 50 volume % to about 70 volume %, can be used as at least a portion of the enriched air and subsequently diluted, if needed, with unprocessed atmospheric air to obtain the desired oxygen concentration.

[00213] In addition to the fuel and oxidant, the combustion chamber can optionally also receive a compressed recycle exhaust gas, such as an exhaust gas recirculation primarily having CO₂ and nitrogen components. The compressed recycle exhaust gas can be derived from the main compressor, for instance, and adapted to help facilitate combustion of the oxidant and fuel, e.g., by moderating the temperature of the combustion products. As can be appreciated, recirculating the exhaust gas can serve to increase CO₂ concentration.

[00214] An exhaust gas directed to the inlet of the expander can be generated as a product of combustion reaction. The exhaust gas can have a heightened CO₂ content based, at least in part, on the introduction of recycled exhaust gas into the combustion reaction. As the exhaust gas expands through the expander, it can generate mechanical power to drive the main compressor, to drive an electrical generator, and/or to power other facilities.

[00215] The power generation system can, in many embodiments, also include an exhaust gas recirculation (EGR) system. In one or more aspects of the invention, the EGR system can include a heat recovery steam generator (HRSG) and/or another similar device fluidly coupled to a steam gas turbine. In at least one embodiment, the combination of the HRSG and the steam gas turbine can be characterized as a power-producing closed Rankine cycle. In combination with the gas turbine system, the HRSG and the steam gas turbine can form part of a combined-cycle power generating plant, such as a natural gas combined-cycle (NGCC) plant. The gaseous exhaust can be introduced to the HRSG in order to generate steam and a cooled exhaust gas. The

HRSG can include various units for separating and/or condensing water out of the exhaust stream, transferring heat to form steam, and/or modifying the pressure of streams to a desired level. In certain embodiments, the steam can be sent to the steam gas turbine to generate additional electrical power.

[00216] After passing through the HRSG and optional removal of at least some H₂O, the CO₂-containing exhaust stream can, in some embodiments, be recycled for use as an input to the combustion reaction. As noted above, the exhaust stream can be compressed (or decompressed) to match the desired reaction pressure within the vessel for the combustion reaction.

Example of Integrated System

[00217] FIG. 8 schematically shows an example of an integrated system including introduction of both CO₂-containing recycled exhaust gas and H₂ or CO from the fuel cell anode exhaust into the combustion reaction for powering a turbine. In FIG. 8, the turbine can include a compressor 802, a shaft 804, an expander 806, and a combustion zone 815. An oxygen source 811 (such as air and/or oxygen-enriched air) can be combined with recycled exhaust gas 898 and compressed in compressor 802 prior to entering combustion zone 815. A fuel 812, such as CH₄, and optionally a stream containing H₂ or CO 187 can be delivered to the combustion zone. The fuel and oxidant can be reacted in zone 815 and optionally but preferably passed through expander 806 to generate electric power. The exhaust gas from expander 806 can be used to form two streams, e.g., a CO₂-containing stream 822 (that can be used as an input feed for fuel cell array 825) and another CO₂-containing stream 892 (that can be used as the input for a heat recovery and steam generator system 890, which can, for example, enable additional electricity to be generated using steam turbines 894). After passing through heat recovery system 890, including optional removal of a portion of H₂O from the CO₂-containing stream, the output stream 898 can be recycled for compression in compressor 802 or a second compressor that is not shown. The proportion of the exhaust from expander 806 used for CO₂-containing stream 892 can be determined based on the desired amount of CO₂ for addition to combustion zone 815.

[00218] As used herein, the EGR ratio is the flow rate for the fuel cell bound portion of the exhaust gas divided by the combined flow rate for the fuel cell bound portion and

the recovery bound portion, which is sent to the heat recovery generator. For example, the EGR ratio for flows shown in FIG. 8 is the flow rate of stream 822 divided by the combined flow rate of streams 822 and 892.

[00219] The CO₂-containing stream 822 can be passed into a cathode portion (not shown) of a molten carbonate fuel cell array 825. Based on the reactions within fuel cell array 825, CO₂ can be separated from stream 822 and transported to the anode portion (not shown) of the fuel cell array 825. This can result in a cathode output stream 824 depleted in CO₂. The cathode output stream 824 can then be passed into a heat recovery (and optional steam generator) system 850 for generation of heat exchange and/or additional generation of electricity using steam turbines 854 (which may optionally be the same as the aforementioned steam turbines 894). After passing through heat recovery and steam generator system 850, the resulting flue gas stream 856 can be exhausted to the environment and/or passed through another type of carbon capture technology, such as an amine scrubber.

[00220] After transport of CO₂ from the cathode side to the anode side of fuel cell array 825, the anode output 835 can optionally be passed into a water gas shift reactor 870. Water gas shift reactor 870 can be used to generate additional H₂ and CO₂ at the expense of CO (and H₂O) present in the anode output 835. The output from the optional water gas shift reactor 870 can then be passed into one or more separation stages 840, such as a cold box or a cryogenic separator. This can allow for separation of an H₂O stream 847 and CO₂ stream 849 from the remaining portion of the anode output. The remaining portion of the anode output 885 can include unreacted H₂ generated by reforming but not consumed in fuel cell array 825. A first portion 845 of the H₂-containing stream 885 can be recycled to the input for the anode(s) in fuel cell array 825. A second portion 887 of stream 885 can be used as an input for combustion zone 815. A third portion 865 can be used as is for another purpose and/or treated for subsequent further use. Although FIG. 8 and the description herein schematically details up to three portions, it is contemplated that only one of these three portions can be exploited, only two can be exploited, or all three can be exploited according to the invention.

[00221] In FIG. 8, the exhaust for the exhaust gas recycle loop is provided by a first heat recovery and steam generator system 890, while a second heat recovery and steam

generator system 850 can be used to capture excess heat from the cathode output of the fuel cell array 825.

[00222] FIG. 9 shows an alternative embodiment where the exhaust gas recycle loop is provided by the same heat recovery steam generator used for processing the fuel cell array output. In FIG. 9, recycled exhaust gas 998 is provided by heat recovery and steam generator system 950 as a portion of the flue gas stream 956. This can eliminate the separate heat recovery and steam generator system associated with the turbine.

[00223] In various embodiments of the invention, the process can be approached as starting with a combustion reaction for powering a turbine, an internal combustion engine, or another system where heat and/or pressure generated by a combustion reaction can be converted into another form of power. The fuel for the combustion reaction can comprise or be hydrogen, a hydrocarbon, and/or any other compound containing carbon that can be oxidized (combusted) to release energy. Except for when the fuel contains only hydrogen, the composition of the exhaust gas from the combustion reaction can have a range of CO₂ contents, depending on the nature of the reaction (e.g., from at least about 2 vol% to about 25 vol% or less). Thus, in certain embodiments where the fuel is carbonaceous, the CO₂ content of the exhaust gas can be at least about 2 vol%, for example at least about 4 vol%, at least about 5 vol%, at least about 6 vol%, at least about 8 vol%, or at least about 10 vol%. Additionally or alternately in such carbonaceous fuel embodiments, the CO₂ content can be about 25 vol% or less, for example about 20 vol% or less, about 15 vol% or less, about 10 vol% or less, about 7 vol% or less, or about 5 vol% or less. Exhaust gases with lower relative CO₂ contents (for carbonaceous fuels) can correspond to exhaust gases from combustion reactions on fuels such as natural gas with lean (excess air) combustion. Higher relative CO₂ content exhaust gases (for carbonaceous fuels) can correspond to optimized natural gas combustion reactions, such as those with exhaust gas recycle, and/or combustion of fuels such as coal.

[00224] In some aspects of the invention, the fuel for the combustion reaction can contain at least about 90 volume % of compounds containing five carbons or less, e.g., at least about 95 volume %. In such aspects, the CO₂ content of the exhaust gas can be at least about 4 vol%, for example at least about 5 vol%, at least about 6 vol%, at least about 7 vol%, or at least about 7.5 vol%. Additionally or alternately, the CO₂ content

of the exhaust gas can be about 13 vol% or less, e.g., about 12 vol% or less, about 10 vol% or less, about 9 vol% or less, about 8 vol% or less, about 7 vol% or less, or about 6 vol% or less. The CO₂ content of the exhaust gas can represent a range of values depending on the configuration of the combustion-powered generator. Recycle of an exhaust gas can be beneficial for achieving a CO₂ content of at least about 6 vol%, while addition of hydrogen to the combustion reaction can allow for further increases in CO₂ content to achieve a CO₂ content of at least about 7.5 vol%.

Alternative Configuration – High Severity NO_x Turbine

[00225] Gas turbines can be limited in their operation by several factors. One typical limitation can be that the maximum temperature in the combustion zone can be controlled below certain limits to achieve sufficiently low concentrations of nitrogen oxides (NO_x) in order to satisfy regulatory emission limits. Regulatory emission limits can require a combustion exhaust to have a NO_x content of about 20 vppm or less, and possible 10 vppm or less, when the combustion exhaust is allowed to exit to the environment.

[00226] NO_x formation in natural gas-fired combustion turbines can be a function of temperature and residence time. Reactions that result in formation of NO_x can be of reduced and/or minimal importance below a flame temperature of about 1500°F, but NO_x production can increase rapidly as the temperature increases beyond this point. In a gas turbine, initial combustion products can be mixed with extra air to cool the mixture to a temperature around 1200°F, and temperature can be limited by the metallurgy of the expander blades. Early gas turbines typically executed the combustion in diffusion flames that had stoichiometric zones with temperatures well above 1500°F, resulting in higher NO_x concentrations. More recently, the current generation of ‘Dry Low Nox’ (DLN) burners can use special pre-mixed burners to burn natural gas at cooler lean (less fuel than stoichiometric) conditions. For example, more of the dilution air can be mixed in to the initial flame, and less can be mixed in later to bring the temperature down to the ~1200°F turbine-expander inlet temperature. The disadvantages for DLN burners can include poor performance at turndown, higher maintenance, narrow ranges of operation, and poor fuel flexibility. The latter can be a concern, as DLN burners can be more difficult to apply to fuels of varying quality (or difficult to apply at all to liquid fuels). For low BTU fuels, such as fuels containing a

high content of CO₂, DLN burners are typically not used and instead diffusion burners can be used. In addition, gas turbine efficiency can be increased by using a higher turbine-expander inlet temperature. However, because there can be a limited amount of dilution air, and this amount can decrease with increased turbine-expander inlet temperature, the DLN burner can become less effective at maintaining low NO_x as the efficiency of the gas turbine improves.

[00227] In various aspects of the invention, a system integrating a gas turbine with a fuel cell for carbon capture can allow use of higher combustion zone temperatures while reducing and/or minimizing additional NO_x emissions, as well as enabling DLN-like NO_x savings via use of turbine fuels that are not presently compatible with DLN burners. In such aspects, the turbine can be run at higher power (i.e., higher temperature) resulting in higher NO_x emissions, but also higher power output and potentially higher efficiency. In some aspects of the invention, the amount of NO_x in the combustion exhaust can be at least about 20 vppm, such as at least about 30 vppm, or at least about 40 vppm. Additionally or alternately, the amount of NO_x in the combustion exhaust can be about 1000 vppm or less, such as about 500 vppm or less, or about 250 vppm or less, or about 150 vppm or less, or about 100 vppm or less. In order to reduce the NO_x levels to levels required by regulation, the resulting NO_x can be equilibrated via thermal NO_x destruction (reduction of NO_x levels to equilibrium levels in the exhaust stream) through one of several mechanisms, such as simple thermal destruction in the gas phase; catalyzed destruction from the nickel cathode catalyst in the fuel cell array; and/or assisted thermal destruction prior to the fuel cell by injection of small amounts of ammonia, urea, or other reductant. This can be assisted by introduction of hydrogen derived from the anode exhaust. Further reduction of NO_x in the cathode of the fuel cell can be achieved via electrochemical destruction wherein the NO_x can react at the cathode surface and can be destroyed. This can result in some nitrogen transport across the membrane electrolyte to the anode, where it may form ammonia or other reduced nitrogen compounds. With respect to NO_x reduction methods involving an MCFC, the expected NO_x reduction from a fuel cell / fuel cell array can be about 80% or less of the NO_x in the input to the fuel cell cathode, such as about 70% or less, and/or at least about 5%. It is noted that sulfidic corrosion can also limit temperatures and affect turbine blade metallurgy in conventional systems.

However, the sulfur restrictions of the MCFC system can typically require reduced fuel sulfur levels that reduce or minimize concerns related to sulfidic corrosion. Operating the MCFC array at low fuel utilization can further mitigate such concerns, such as in aspects where a portion of the fuel for the combustion reaction corresponds to hydrogen from the anode exhaust.

Operating the Fuel Cell at Low Voltage

[00228] The conventional fuel cell practice teaches that molten carbonate and solid oxide fuel cells should be operated to maximize power density. The ability to maximize power density can be limited by a need to satisfy other operating constraints, such as temperature differential across the fuel cell. Generally, fuel cell parameters are selected to optimize power density as much as is feasible given other constraints. As an example, Figure 6-13 of the NETL Fuel Cell Handbook Seventh Edition, EG & G Technical Services, Inc., November 2004, pp. 6-32-6-33, and the discussion surrounding Figure 6-13 teach that operation of a fuel cell at low fuel utilization is hindered by the decrease in fuel conversion that occurs as the fuel utilization is decreased. Generally, a higher operating voltage V_A is desired to increase power density.

[00229] An aspect of the invention can be to operate the fuel cell at low fuel utilization, and to overcome the problem of decreased CH_4 conversion by decreasing the voltage. The decreased voltage can increase the amount of heat available for use in the conversion reactions. In various aspects, the fuel cell can be operated at a voltage V_A of less than about 0.7 Volts, for example less than about 0.68 V, less than about 0.67 V, less than about 0.66 V, or about 0.65 V or less. Additionally or alternatively, the fuel cell can be operated at a voltage V_A of at least about 0.60, for example at least about 0.61, at least about 0.62, or at least about 0.63. In so doing, energy that would otherwise leave the fuel cell as electrical energy at high voltage can remain within the cell as heat as the voltage is lowered. This additional heat can allow for increased endothermic reactions to occur, for example increasing the CH_4 conversion to syngas.

[00230] A series of simulations were performed to illustrate the benefits of operating a molten carbonate fuel cell according to the invention. Specifically, the simulations were performed to illustrate the benefit of running the fuel cell at lower voltage across different

fuel utilizations. The impact of running the fuel cell at lower voltage and low fuel utilization is shown in FIGS. 16 and 17. FIG. 16 illustrates a model of the fuel cell in a representation analogous to Figure 6-13 of the NETL Fuel Cell Handbook Seventh Edition, EG & G Technical Services, Inc., November 2004, pp. 6-32-6-33. The simulations used to produce the results shown in FIG. 16 were run at a constant CH_4 flow rate. FIG. 16 shows the conversion 1620 that can occur at different fuel utilization 1610 percentages for different operating voltages. At high voltage (0.8V) 1650, as the fuel utilization is decreased, the CH_4 conversion also appeared to be decreased to a low level. As the voltage is lowered (to 0.7V, 1640, and 0.6V, 1630), the CH_4 conversion at each fuel utilization point modeled appeared to be higher than the corresponding conversion at 0.8V. While FIG. 16 shows only a few percentage increase in CH_4 conversion, the impact can actually be quite substantial, as illustrated in FIG. 17.

[00231] The simulations used to produce the results shown in FIG. 17 were not performed at a constant flow rate of CH_4 , but at a constant fuel cell area instead. In FIG. 17, the same operation of the fuel cell was illustrated not on a percentage of CH_4 conversion basis, but on an absolute flow rate of CH_4 for a fixed fuel cell area. The x-axis 1710 shows the fuel utilization and the y-axis 1720 shows normalized CH_4 conversion. Plot 1730 shows simulated results produced at 0.6V. Plot 1740 shows the simulated results produced at 0.7V. Plot 1750 shows the simulated results produced at 0.8V. As the fuel utilization is decreased, and especially as the voltage is decreased, the current density appeared to be increased by more than a factor of 5 for the data shown in FIGS. 16 and 17. As such, the power density can be increased by lowering the operating voltage under operating conditions consistent with aspects of the invention. The increased power density and lower voltage seems to be contrary to the affect achieved during conventional operations, where lower operating voltage typically results in lower power density. As shown in FIG. 17, the impact on total CH_4 conversion appeared significant: much higher conversion of CH_4 , measured as an absolute flow rate, was achieved at lower fuel utilization when the voltage was decreased.

Additional Embodiments

[00232] Embodiment 1. A method for capturing carbon dioxide from a combustion source, the method comprising: introducing a fuel stream and an O₂-containing stream into a combustion zone; performing a combustion reaction in the combustion zone to generate a combustion exhaust, the combustion exhaust comprising CO₂; processing a cathode inlet stream, the cathode inlet stream comprising at least a first portion of the combustion exhaust, with a fuel cell array of one or more molten carbonate fuel cells to form a cathode exhaust stream from at least one cathode outlet of the fuel cell array, the one or more molten carbonate fuel cells comprising one or more fuel cell anodes and one or more fuel cell cathodes, the one or more molten carbonate fuel cells being operatively connected to the combustion zone through at least one cathode inlet; reacting carbonate from the one or more fuel cell cathodes with H₂ within the one or more fuel cell anodes to produce electricity and an anode exhaust stream from at least one anode outlet of the fuel cell array, the anode exhaust stream comprising CO₂ and H₂; separating CO₂ from the anode exhaust stream in one or more separation stages to form a CO₂-depleted anode exhaust stream; passing at least a combustion-recycle portion of the CO₂-depleted anode exhaust stream to the combustion zone; and recycling at least an anode-recycle portion of the CO₂-depleted anode exhaust stream to the one or more fuel cell anodes.

[00233] Embodiment 2. The method of Embodiment 1, wherein a fuel utilization in the one or more fuel cell anodes is about 65% or less (e.g., about 60% or less).

[00234] Embodiment 3. The method of Embodiment 2, wherein the fuel utilization in the one or more fuel cell anodes is about 30% to about 50%.

[00235] Embodiment 4. The method of Embodiment 2, wherein the one or more fuel cell anodes comprise a plurality of anode stages and the one or more fuel cell cathodes comprise a plurality of cathode stages, wherein a low utilization anode stage in the plurality of anode stages has an anode fuel utilization of 65% or less (such as about 60% or less), the low utilization anode stage corresponding to high utilization cathode stage of the plurality of cathode stages, the high utilization cathode stage having a CO₂ content at a cathode inlet as high as or higher than a CO₂ at a cathode inlet of any other cathode stage of the plurality of cathode stages.

[00236] Embodiment 5. The method of Embodiment 4, wherein the fuel utilization in the low utilization anode stage is at least about 40%, (e.g., at least about 45% or at least about 50%).

[00237] Embodiment 6. The method of Embodiment 4, wherein a fuel utilization in each anode stage of the plurality of anode stages is about 65% or less (e.g., about 60% or less).

[00238] Embodiment 7. The method of any of the above embodiments, wherein the combustion-recycle portion of the CO₂-depleted anode exhaust stream comprises at least about 25% of the CO₂-depleted anode exhaust stream, and wherein the anode-recycle portion of the CO₂-depleted anode exhaust stream comprises at least about 25% of the CO₂-depleted anode exhaust stream.

[00239] Embodiment 8. The method of Embodiment 7, further comprising passing carbon-containing fuel into the one or more fuel cell anodes, the carbon-containing fuel optionally comprising CH₄.

[00240] Embodiment 9. The method of Embodiment 8, further comprising: reforming at least a portion of the carbon-containing fuel to generate H₂; and passing at least a portion of the generated H₂ into the one or more fuel cell anodes.

[00241] Embodiment 10. The method of Embodiment 8, wherein the carbon-containing fuel is passed into the one or more fuel cell anodes without passing the carbon-containing fuel into a reforming stage prior to entering the one or more fuel cell anodes.

[00242] Embodiment 11. The method of any of the above embodiments, wherein the combustion exhaust comprises about 10 vol% or less of CO₂ (e.g., 8 vol% or less of CO₂), the combustion exhaust optionally comprising at least about 4 vol% of CO₂.

[00243] Embodiment 12. The method of any of the above Embodiments, further comprising recycling a second portion of the combustion exhaust to the combustion zone, the second portion of the combustion exhaust optionally comprising at least about 6 vol% CO₂.

[00244] Embodiment 13. The method of Embodiment 12, wherein recycling the second portion of the combustion exhaust to the combustion zone comprises: exchanging heat between a second portion of the combustion exhaust and an H₂O-containing stream to form steam; separating water from the second portion of the combustion exhaust to form an H₂O-

depleted combustion exhaust stream; and passing at least a portion of the H₂O-depleted combustion exhaust into the combustion zone.

[00245] Embodiment 14. The method of any of the above embodiments, wherein the anode exhaust stream, prior to the separating CO₂ from the anode exhaust stream in one or more separation stages, comprises at least about 5.0 vol% of H₂ (e.g., at least about 10 vol% or at least about 15 vol%).

[00246] Embodiment 15. The method of any of the above embodiments, further comprising exposing the anode exhaust stream to a water gas shift catalyst to form a shifted anode exhaust stream prior to the separating CO₂ from the anode exhaust stream in one or more separation stages, a H₂ content of the shifted anode exhaust stream after exposure to the water gas shift catalyst being greater than a H₂ content of the anode exhaust stream prior to exposure to the water gas shift catalyst.

[00247] Embodiment 16. The method of any of the above Embodiments, wherein the combustion-recycle portion of the CO₂-depleted anode exhaust stream is combined with the fuel stream prior to passing the combustion-recycle portion of the CO₂-depleted anode exhaust stream to the combustion zone.

[00248] Embodiment 17. The method of any of the above embodiments, wherein a cathode exhaust stream has a CO₂ content of about 2.0 vol% or less (e.g., about 1.5 vol% or less or about 1.2 vol% or less).

[00249] Embodiment 18. The method of any of the above embodiments, wherein separating CO₂ from the anode exhaust stream in one or more separation stages comprises: optionally separating water from the anode exhaust stream to form an optionally H₂O-depleted anode exhaust stream; cooling the optionally H₂O-depleted anode exhaust stream to form a condensed phase of CO₂.

EXAMPLES

[00250] A series of simulations were performed in order to demonstrate the benefits of using an improved configuration for using a fuel cell for CO₂ separation. The simulations were based on empirical models for the various components in the power generation

system. The simulations were based on determining steady state conditions within a system based on mass balance and energy balance considerations.

[00251] For the combustion reaction for the turbine, the model included an expected combustion energy value and expected combustion products for each fuel component in the feed to the combustion zone (such as C₁-C₄ hydrocarbon, H₂, and/or CO). This was used to determine the combustion exhaust composition. An initial reforming zone prior to the anode can be operated using an “idealized” reforming reaction to convert CH₄ to H₂. The anode reaction was modeled to also operate to perform further reforming during anode operation. It is noted that the empirical model for the anode did not require an initial H₂ concentration in the anode for the reforming in the anode to take place. Both the anode and cathode reactions were modeled to convert expected inputs to expected outputs at a utilization rate that was selected as a model input. The model for the initial reforming zone and the anode/cathode reactions included an expected amount of heat energy needed to perform the reactions. The model also determined the electrical current generated based on the amount of reactants consumed in the fuel cell and the utilization rates for the reactants based on the Nernst equation. For species that were input to either the combustion zone or the anode/cathode fuel cell that did not directly participate in a reaction within the modeled component, the species were passed through the modeled zone as part of the exhaust or output.

[00252] In addition to the chemical reactions, the components of the system had expected heat input/output values and efficiencies. For example, the cryogenic separator had an energy that was required based on the volume of CO₂ and H₂O separated out, as well as an energy that was required based on the volume of gas that was compressed and that remained in the anode output flow. Expected energy consumption was also determined for a water gas shift reaction zone, if present, and for compression of recycled exhaust gas. An expected efficiency for electric generation based on steam generated from heat exchange was also used in the model.

[00253] The basic configuration used for the simulations included a combustion turbine combine including a compressor, a combustion zone, and an expander, similar to the arrangement in FIG. 8. In the base configuration, a natural gas fuel input 812 was provided

to the combustion zone 815. The natural gas input included ~93% CH₄, ~2% C₂H₆, ~2% CO₂, and ~3% N₂. The oxidant feed 811 to the compressor 802 had a composition representative of air, including about 70% N₂ and about 18% O₂. After passing through the expander 806, a portion 892 of the combustion exhaust gas was passed through a heat recovery steam generation system 890 and then recycled to the compressor 802. The remainder of the combustion exhaust 822 was passed into the fuel cell cathode. After passing through the fuel cell cathode, the cathode exhaust 824 exited the system. Unless otherwise specified, the portion of the combustion exhaust 892 recycled back to the combustion zone was ~35%. This recycled portion of the combustion exhaust served to increase the CO₂ content of the output from the combustion zone. Because the fuel cell area was selected to reduce the CO₂ concentration in the cathode output to a fixed value of ~1.45%, recycling the combustion exhaust was found to improve the CO₂ capture efficiency.

[00254] In the base configuration, the fuel cell was modeled as a single fuel cell of an appropriate size to process the combustion exhaust. This was done to represent use of a corresponding plurality of fuel cells (fuel cell stacks) arranged in parallel having the same active area as the modeled cell. Unless otherwise specified, the fuel utilization in the anode of the fuel cell was set to ~75%. The fuel cell area was allowed to vary, so that the selected fuel utilization results in the fuel cell operating at a constant fuel cell voltage of ~0.7 volts and a constant CO₂ cathode output/exhaust concentration of ~1.45 vol%.

[00255] In addition to the chemical reactions, the components of the system had expected heat input/output values and efficiencies. For example, the cryogenic separator had an energy that was required based on the volume of CO₂ and H₂O separated out, as well as an energy that was required based on the volume of gas that was compressed and that remained in the anode output flow. Expected energy consumption was also determined for a water gas shift reaction zone, if present, and for compression of recycled exhaust gas. An expected efficiency for electric generation based on steam generated from heat exchange was also used in the model.

[00256] The basic configuration used for the simulations included a combustion turbine combine including a compressor, a combustion zone, and an expander. In the base

configuration, a natural gas fuel input was provided to the combustion zone. The natural gas input included ~93% CH₄, ~2% C₂H₆, ~2% CO₂, and ~3% N₂. The oxidant feed to the compressor had a composition representative of air, including about 70% N₂ and about 18% O₂. After passing through the expander, a portion of the combustion exhaust gas was passed through a heat recovery steam generation system and then recycled to the compressor. The remainder of the combustion exhaust was passed into the fuel cell cathode. After passing through the fuel cell cathode, the cathode exhaust exited the system. Unless otherwise specified, the portion of the combustion exhaust recycled back to the combustion zone was ~35%. This recycled portion of the combustion exhaust served to increase the CO₂ content of the output from the combustion zone. Because the fuel cell area was selected to reduce the CO₂ concentration in the cathode output to a fixed value of ~1.45%, recycling the combustion exhaust was found to improve the CO₂ capture efficiency.

[00257] In the base configuration, the fuel cell was modeled as a single fuel cell of an appropriate size to process the combustion exhaust. This was done to represent use of a corresponding plurality of fuel cells (fuel cell stacks) arranged in parallel having the same active area as the modeled cell. Unless otherwise specified, the fuel utilization in the anode of the fuel cell was set to ~75%. The fuel cell area was allowed to vary, so that the selected fuel utilization results in the fuel cell operating at a constant fuel cell voltage of ~0.7 volts and a constant CO₂ cathode output/exhaust concentration of ~1.45 vol%.

[00258] In the base configuration, an anode fuel input flow provided the natural gas composition described above as a feed to the anode. Steam was also present to provide a steam to carbon ratio in the input fuel of ~2:1. Optionally, the natural gas input can undergo reforming to convert a portion of the CH₄ in the natural gas to H₂ prior to entering the anode. When a prior reforming stage is present, ~20% of the CH₄ could be reformed to generate H₂ prior to entering the anode. The anode output was passed through a cryogenic separator for removal of H₂O and CO₂. The remaining portion of the anode output after separation was processed depending on the configuration for each Example.

[00259] For a given configuration, a variety of values could be calculated at steady state. For the fuel cell, the amount of CO₂ in the anode exhaust and the amount of O₂ in the cathode exhaust was determined. The voltage for the fuel cell was fixed at ~0.7 V within

each calculation. For conditions that could result in a higher maximum voltage, the voltage was stepped down in exchange for additional current, in order to facilitate comparison between simulations. The area of fuel cell required to achieve a final cathode exhaust CO₂ concentration of ~1.45 vol% was also determined to allow for determination of a current density per fuel cell area.

[00260] Another set of values were related to CO₂ emissions. The percentage of CO₂ captured by the system was determined based on the total CO₂ generated versus the amount of CO₂ (in Mtons/year) captured and removed via the cryogenic separator. The CO₂ not captured corresponded to CO₂ "lost" as part of the cathode exhaust. Based on the amount of CO₂ captured, the area of fuel cell required per ton of CO₂ captured could also be determined.

[00261] Other values determined in the simulation included the amount of H₂ in the anode feed relative to the amount of carbon and the amount of N₂ in the anode feed. It is noted that the natural gas used for both the combustion zone and the anode feed included a portion of N₂, as would be expected for a typical real natural gas feed. As a result, N₂ was present in the anode feed. The amount of heat (or equivalently steam) required for heating the anode feed for reforming was also determined. A similar power penalty was determined based on the power required for compression and separation in the cryogenic separation stages. For configurations where a portion of the anode exhaust was recycled to the combustion turbine, the percentage of the turbine fuel corresponding to H₂ was also determined. Based on the operation of the turbine, the fuel cell, and the excess steam generated, as well as any power consumed for heating the reforming zone, compression, and/or separation, a total net power was determined for the system to allow for a net electrical efficiency to be determined based on the amount of natural gas (or other fuel) used as an input for the turbine and the anode.

[00262] FIGS. 10, 11, and 12 show results from simulations performed based on several configuration variants. FIG. 10 shows configurations corresponding to a base configuration as well as several configurations where a portion of the anode output was recycled to the anode input. In FIG. 10, a first configuration (1a) was based on passing the remaining anode output after the carbon dioxide and water separation stage(s) into a combustor located after

the turbine combustion zone. This provided heat for the reforming reaction and also provided additional carbon dioxide for the cathode input. Configuration 1a was representative of a conventional system, such as the aforementioned Manzolini reference, with the exception that the Manzolini reference did not describe recycle of exhaust gas. Use of the anode output as a feed for the combustor resulted in a predicted fuel cell area of ~208 km² in order to reduce the CO₂ content of the cathode output to ~1.45 vol%. The amount of CO₂ lost as part of the cathode exhaust was ~111 lbs CO₂/MWhr. Due to the large fuel cell area required for capturing the CO₂, the net power generated was ~724 MW per hour. Based on these values, the amount of fuel cell area needed to capture a fixed amount of CO₂ could be calculated, such as an area of fuel cell needed to capture a megaton of CO₂ during a year of operation. For Configuration 1a, the area of fuel cell required was ~101.4 km²*year/Mton-CO₂. The efficiency for generation of electrical power relative to the energy content of all fuel used in the power generation system was ~58.9%. By comparison, the electrical efficiency for the turbine without any form of carbon capture was ~61.1%.

[00263] In a second set of configurations (2a – 2e), the anode output was recycled to the anode input. Configuration 2a represented a basic recycle of the anode output after separation to the anode input. Configuration 2b included a water gas shift reaction zone prior to the carbon dioxide separation stages. Configuration 2c did not include a reforming stage prior to the anode input. Configuration 2d included a reforming stage, but was operated with a fuel utilization of ~50% instead of ~75%. Configuration 2e was operated with a fuel utilization of ~50% and did not have a reforming stage prior to the anode.

[00264] Recycling the anode output back to the anode input, as shown in Configuration 2a, resulted in a reduction of the required fuel cell area to ~161 km². However, the CO₂ loss from the cathode exhaust was increased to ~123 lbs CO₂/MWhr. This was due to the fact that additional CO₂ was not being added to the cathode input by the combustion of anode exhaust in a combustor after the turbine. Instead, the CO₂ content of the cathode input was based only on the CO₂ output of the combustion zone. The net result in Configuration 2a was a lower area of fuel cell per ton of CO₂ captured of ~87.5 km²*year/Mton-CO₂, but a modestly higher amount of CO₂ emissions. Due to the reduced fuel cell area, the total power generated was ~661 MW. Although the net power generated

in Configuration 2a was about 10% less than the net power in Configuration 1a, the fuel cell area was reduced by more than 20%. The electrical efficiency was ~58.9%.

[00265] In Configuration 2b, the additional water gas shift reaction zone increased the hydrogen content delivered to the anode, which reduced the amount of fuel needed for the anode reaction. Including the water gas shift reaction zone in Configuration 2b resulted in a reduction of the required fuel cell area to ~152 km². The CO₂ loss from the cathode exhaust was ~123 lbs CO₂/MWhr. The area of fuel cell per megaton of CO₂ captured was ~82.4 km²*year/Mton-CO₂. The total power generated was ~664 MW. The electrical efficiency was ~59.1%.

[00266] Configuration 2c can take further advantage of the hydrogen content in the anode recycle by eliminating the reforming of fuel occurring prior to entering the anode. In Configuration 2c, reforming can still occur within the anode itself. However, in contrast to a conventional system incorporating a separate reforming stage prior to entry into the fuel cell anode, Configuration 2c relied on the hydrogen content of the recycled anode gas to provide the minimum hydrogen content for sustaining the anode reaction. Because a separate reforming stage was not required, the heat energy was not consumed to maintain the temperature of the reforming stage. Configuration 2c resulted in a reduction of the required fuel cell area to ~149 km². The CO₂ loss from the cathode exhaust was ~122 lbs CO₂/MWhr. The area of fuel cell per ton of CO₂ captured was ~80.8 km²*year/Mton-CO₂. The total power generated was ~676 MW. The electrical efficiency was ~60.2%. Based on the simulation results, eliminating the reforming step seemed to have only a modest impact on the required fuel cell area, but the electrical efficiency appeared to be improved by about 1% relative to Configuration 2b. For an industrial scale power generation plant, an efficiency improvement of even only 1% is believed to represent an enormous advantage over the course of a year in power generation.

[00267] In Configuration 2d, reforming was still performed to convert ~20% of the methane input to the anode into H₂ prior to entering the anode. Instead, the fuel utilization within the anode was reduced from ~75% to ~50%. This resulted in a substantial reduction of the required fuel cell area to ~113 km². The CO₂ loss from the cathode exhaust was ~123 lbs CO₂/MWhr. The area of fuel cell per ton of CO₂ captured was ~61.3 km²*year/Mton-

CO₂. The total power generated was ~660 MW. The electrical efficiency was ~58.8%. Based on the simulation results, reducing the fuel utilization provided a substantial reduction in fuel cell area. Additionally, in comparison with Configurations 2b and 2e, Configuration 2d unexpectedly provided the lowest fuel cell area for achieving the desired level of CO₂ removal.

[00268] Configuration 2e incorporated both the reduced fuel utilization of ~50% as well as elimination of the reforming stage prior to the anode inlet. This configuration provided a combination of improved electrical efficiency and reduced fuel cell area. However, the fuel cell area was slightly larger than the fuel cell area required in Configuration 2d. This was surprising, as eliminating the reforming stage prior to the anode inlet in Configuration 2c reduced the fuel cell area in comparison with Configuration 2b. Based on this, it would have been expected that Configuration 2e would provide a further reduction in fuel cell area relative to Configuration 2d. In Configuration 2e, the CO₂ loss from the cathode exhaust was ~124 lbs CO₂/MWhr. The area of fuel cell per ton of CO₂ captured of ~65.0 km²*year/Mton-CO₂. The total power generated was ~672 MW. The electrical efficiency was ~59.8%. It is noted that Configuration 2d generated only 2% less power than Configuration 2e, while the fuel cell area of Configuration 2d was at least 6% lower than Configuration 2e.

[00269] The simulation results for Configurations 2b-2e provide a comparison of how reducing the anode fuel utilization can impact the total electrical efficiency in a power generation system. Even though reducing the fuel utilization to ~50% in Configuration 2d led to a reduction in fuel cell area relative to Configuration 2b, the reduced anode fuel utilization also appeared to result in a reduction in electrical efficiency from ~59.1% to ~58.8%. This was in general agreement with conventional views on fuel utilization for molten carbonate fuel cells, where high fuel utilization values can be used to allow for efficient use of fuel delivered to the system. In the simulations for Configurations 2b-2e, in order to achieve an improvement in total electrical efficiency, the low fuel utilization can be combined with reducing and/or eliminating the amount of reforming, as shown in Configuration 2e.

[00270] FIG. 11 shows simulation results for additional configurations that included recycle of at least a portion of the anode exhaust to the combustion zone for the turbine. In FIG. 11, Configuration 1b was similar to Configuration 1a (shown in FIG. 10), but also included a water-gas shift reaction stage prior to the CO₂ separation stages. Thus, Configuration 1b was representative of a conventional system, such as the aforementioned Manzolini reference, with the exceptions that the Manzolini reference did not describe a water-gas shift reaction stage or recycle of exhaust gas. The required fuel cell area to achieve a CO₂ concentration in the cathode exhaust of ~1.45% was ~190 km². The amount of CO₂ lost as part of the cathode exhaust was ~117 lbs CO₂/MWhr. The area of fuel cell per ton of CO₂ captured was ~97.6 km²*year/Mton-CO₂. The total power generated was ~702 MW. The electrical efficiency was ~59.1%.

[00271] Configurations 3a, 3b, and 3d correspond to configurations where the anode output was used as an input for the combustion zone of the turbine. In these configurations, the H₂ content of the anode output was available for use as a fuel in the turbine combustion zone. This appeared to be advantageous, as the carbon-containing fuel used to generate the H₂ was generated in the anode recycle loop, where the majority of the resulting CO₂ can be removed via the cryogenic separation stages. This could also result in a reduction of the amount of carbon containing fuel delivered to the combustion zone, but the reduction in carbon-containing fuel in the combustion zone could also result in the reduction of the CO₂ concentration in the input to the cathode.

[00272] Configuration 3a was a configuration similar to Configuration 1a, but with recycle of the anode exhaust to the combustion zone. The required fuel cell area to achieve a CO₂ concentration in the cathode exhaust of ~1.45% was ~186 km². The amount of CO₂ lost as part of the cathode exhaust was ~114 lbs CO₂/MWhr. The area of fuel cell per ton of CO₂ captured was ~100.3 km²*year/Mton-CO₂. The total power generated was ~668 MW. The electrical efficiency was ~59.7%. Relative to Configuration 1a, Configuration 3a had a lower total amount of CO₂ generated (~2.05 Mtons/year for Configuration 1a vs. ~1.85 Mtons/year for Configuration 3a). This was believed to be due to the reduced amount of carbon-containing fuel delivered to the combustion zone. However, this also appeared to result in a reduced CO₂ concentration delivered to the cathode input, which caused the

model to show a reduced efficiency of CO₂ removal for Configuration 3a. As a result, the net amount of CO₂ exiting in the cathode exhaust was comparable for Configuration 1a and Configuration 3a. However, Configuration 3a appeared to have several advantages relative to Configuration 1a. First, Configuration 3a required a lower fuel cell area, so that the system in Configuration 3a would likely have a reduced cost. Additionally, the system in Configuration 3a appeared to have improved electrical efficiency, which can indicate lower fuel usage, even after adjusting for the different power output of the configurations.

[00273] Configuration 3b was similar to Configuration 3a, but also included a water gas shift reaction zone prior to the cryogenic separation stages. The required fuel cell area to achieve a CO₂ concentration in the cathode exhaust of ~1.45% was ~173 km². The amount of CO₂ lost as part of the cathode exhaust was ~124 lbs CO₂/MWhr. The area of fuel cell per ton of CO₂ captured was ~96.1 km²*year/Mton-CO₂. The total power generated was ~658 MW. The electrical efficiency was ~59.8%. Configuration 3b appeared to have increased CO₂ emission via the cathode exhaust. This was believed to be due to the additional hydrogen delivered to the combustion zone, which can result in a corresponding reduction in the amount of CO₂ the combustion exhaust used for the cathode input. However, the fuel cell area was further reduced.

[00274] Configuration 3d was similar to Configuration 3b, but the anode fuel utilization was reduced from ~75% to ~50%. The required fuel cell area to achieve a CO₂ concentration in the cathode exhaust of ~1.45% was ~132 km². The amount of CO₂ lost as part of the cathode exhaust was ~128 lbs CO₂/MWhr. The area of fuel cell per ton of CO₂ captured was ~77.4 km²*year/Mton-CO₂. The total power generated was ~638 MW. The electrical efficiency was ~60.7%. Based on the simulation results, reducing the fuel utilization in the anode appeared to result in a substantial improvement in electrical efficiency relative to Configuration 3b. This was believed to be due to the additional hydrogen delivered to the combustion zone for the turbine. For comparison, the electrical efficiency of the turbine without any carbon capture was ~61.1%. Thus, the combination of recycling anode exhaust to the combustion zone and lower fuel utilization appeared to allow an electrical efficiency to be achieved approaching the efficiency without a carbon capture system.

[00275] FIG. 12 shows simulation results for additional configurations including recycle of at least a portion of the anode exhaust to both the combustion zone for the turbine and to the anode inlet. Configurations 4d, 4e, and 4f represent configurations where the remaining anode exhaust after separation (removal) of CO₂ and H₂O was divided evenly between recycle to the anode input and recycle to the combustion zone for the turbine. In order to provide sufficient hydrogen for both the anode input and the combustion zone, the anode fuel utilization in Configurations 4d and 4e was set to ~50%. Configurations 4d and 4e both included a water gas shift reaction zone prior to the separation stages. Configuration 4d included a separate reforming stage for reforming ~20% of the additional fuel input to the anode prior to the fuel entering the anode. Configuration 4e did not include a reforming stage prior to the fuel entering the anode input. Configuration 4f was similar to Configuration 4e, with the exception that the anode fuel utilization in Configuration 4f was ~33%, as opposed to the ~50% in Configuration 4e.

[00276] Configuration 4d appeared to show the benefits of recycling the anode exhaust to both the anode input and the combustion zone. Relative to Configuration 2d, Configuration 4d appeared to provide an electrical efficiency about a full percentage point greater. Relative to Configuration 3d, Configuration 4d provided a reduced fuel cell area. In Configuration 4d, the required fuel cell area to achieve a CO₂ concentration in the cathode exhaust of ~1.45% was ~122 km². The amount of CO₂ lost as part of the cathode exhaust was ~126 lbs CO₂/MWhr. The area of fuel cell per ton of CO₂ captured was ~63.4 km²*year/Mton-CO₂. The total power generated was ~650 MW. The electrical efficiency was ~59.9%.

[00277] Removing the pre-reforming stage in Configuration 4e appeared to provide further benefits. The required fuel cell area to achieve a CO₂ concentration in the cathode exhaust of ~1.45% was ~112 km². The amount of CO₂ lost as part of the cathode exhaust was ~126 lbs CO₂/MWhr. The area of fuel cell per ton of CO₂ captured was ~63.4 km²*year/Mton-CO₂. The total power generated was ~665 MW. The electrical efficiency was ~61.4%. It is noted that the electrical efficiency was actually greater than the efficiency of the turbine without any type of carbon capture (~61.1%).

[00278] Reducing the anode fuel utilization in Configuration 4f appeared to provide still further benefits with regard to both reducing fuel cell area and increasing electrical efficiency. The required fuel cell area to achieve a CO₂ concentration in the cathode exhaust of ~1.45% was ~86 km². The amount of CO₂ lost as part of the cathode exhaust was ~126 lbs CO₂/MWhr. The area of fuel cell per ton of CO₂ captured was ~50.6 km²*year/Mton-CO₂. The total power generated was ~654 MW. The electrical efficiency was ~62.4%. It is noted that the electrical efficiency is actually greater than the efficiency of the turbine without any type of carbon capture (61.1%).

[00279] Configurations 5d, 5e, and 5f were similar to Configurations 4d, 4e, and 4f, with the exception that the exhaust gas recycle rate in Configurations 5d, 5e, and 5f was increased to ~45%. Configurations 5d, 5e, and 5f had similar fuel cell areas and appeared to provide similar electrical efficiency, as compared to Configurations 4d, 4e, and 4f. However, the net amount of CO₂ allowed to leave the system via the cathode exhaust was reduced by about 15% to about 20%, when the exhaust gas recycle rate was increased from about 30% to about 45%.

[00280] FIG. 13 shows results from simulations performed based on several configuration variants and alternative operating conditions. The simulations of FIG. 13 took into account more factors than the simulations explained previously with reference FIG. 10. Otherwise, the simulations shown in FIG. 13 were similar to the simulations shown in FIG. 10, with a few variations added. For example, each case was simulated at about 0.65 volts in addition to the about 0.7 volts used in the FIG. 10 simulations. In addition, a case with 0% EGR was added to each configuration. FIG. 13 shows configurations corresponding to a base configuration as well as several configurations where a portion of the anode output was recycled to the anode input. Unless noted, the exhaust gas recycle was about 35% for the simulated results shown in FIG. 10. In FIG. 13, each configuration was run with either ~35% or 0% EGR as shown.

[00281] In addition to different configurations and alternative operating conditions, FIG. 13 shows additional parameters that were not shown in FIG. 10. For example, FIG. 13 includes the approximate fuel utilization, approximate steam to carbon ratio, EGR recycle %, whether or not water gas shift reactors were present in the configuration to process the

anode exhaust, the approximate internal reforming %, the approximate CO₂ concentration in the cathode inlet, and the approximate O₂ content in the cathode exhaust.

[00282] In FIG. 13, a first configuration (0) shown in column 1304 was based on passing the remaining anode output after the carbon dioxide and water separation stage(s) into a combustor located after the turbine combustion zone. This provided heat for the reforming reaction and also provided additional carbon dioxide for the cathode input. Configuration 0 did not include EGR. Configuration 0 provided a useful base case for comparison with other simulations that did not include EGR. Configuration 0 was representative of a conventional system, such as the aforementioned Manzolini reference. Use of the anode output as a feed for the combustor resulted in a predicted fuel cell area of ~185 km² in order to reduce the CO₂ content of the cathode output to ~1.5 vol%. The amount of CO₂ lost as part of the cathode exhaust was ~212 lbs CO₂/MWhr. Due to the large fuel cell area required for capturing the CO₂, the net power generated was ~679 MW per hour. Based on these values, the amount of fuel cell area needed to capture a fixed amount of CO₂ could be calculated, such as an area of fuel cell needed to capture a megaton of CO₂ during a year of operation. For Configuration 0, the area of fuel cell required to capture a megaton was ~113.9 km²*year/Mton-CO₂. The efficiency for generation of electrical power relative to the energy content of all fuel used in the power generation system was ~57.6%.

[00283] In FIG. 13, a second base configuration (1a) shown in column 1306 was based on passing the remaining anode output after the carbon dioxide and water separation stage(s) into a combustor located after the turbine combustion zone. This provided heat for the reforming reaction and also provided additional carbon dioxide for the cathode input. Configuration 1a was representative of a conventional system, such as the aforementioned Manzolini reference, with the exception that the Manzolini reference did not describe recycle of exhaust gas. Use of the anode output as a feed for the combustor resulted in a predicted fuel cell area of ~215 km² in order to reduce the CO₂ content of the cathode output to ~1.5 vol%. The amount of CO₂ lost as part of the cathode exhaust was ~148 lbs CO₂/MWhr. Due to the large fuel cell area required for capturing the CO₂, the net power generated was ~611 MW per hour. Based on these values, the amount of fuel cell area needed to capture a fixed amount of CO₂ could be calculated, such as an area of fuel cell

needed to capture a megaton of CO₂ during a year of operation. For Configuration 1a, the area of fuel cell required to capture a megaton was ~114.2 km²*year/Mton-CO₂. The efficiency for generation of electrical power relative to the energy content of all fuel used in the power generation system was ~51.2%. Base case 1a may be compared to base case 0 to show a result of adding exhaust gas recycle at ~35%.

[00284] In FIG. 13, a third base configuration (1b) shown in column 1308 was based on passing the remaining anode output after the carbon dioxide and water separation stage(s) into a combustor located after the turbine combustion zone. This provided heat for the reforming reaction and also provided additional carbon dioxide for the cathode input. Base case 1b included water gas shift reactors to process the anode exhaust prior to carbon dioxide and water separation stage(s). Configuration 1b was representative of a conventional system, such as the aforementioned Manzolini reference, with the exceptions that the Manzolini reference did not describe recycle of exhaust gas or water gas shift reactors. Use of the anode output as a feed for the combustor resulted in a predicted fuel cell area of ~197 km² in order to reduce the CO₂ content of the cathode output to ~1.5 vol%. The amount of CO₂ lost as part of the cathode exhaust was ~147.5 lbs CO₂/MWhr. Due to the large fuel cell area required for capturing the CO₂, the net power generated was ~609 MW per hour. Based on these values, the amount of fuel cell area needed to capture a fixed amount of CO₂ could be calculated, such as an area of fuel cell needed to capture a megaton of CO₂ during a year of operation. For Configuration 1b, the area of fuel cell required to capture a megaton was ~107.6 km²*year/Mton-CO₂. The efficiency for generation of electrical power relative to the energy content of all fuel used in the power generation system was ~52.1%. Base case 1b may be compared to base case 1a to show a result of adding water gas shift reactors. Base case 1b may be compared to base case 0 to show a result of adding water gas shift reactors and ~35% exhaust gas recycle.

[00285] In a second set of configurations (2a – 2e), the anode output was recycled to the anode input. Configuration 2a represented a basic recycle of the anode output after water and carbon dioxide separation to the anode input. Configuration 2b included a water gas shift reaction zone prior to the carbon dioxide separation stages. Configuration 2c did not include a reforming stage prior to the anode input. Configuration 2d included a reforming

stage, but was operated with a fuel utilization of ~50% instead of ~75%. Configuration 2e was operated with a fuel utilization of ~50% and did not have a reforming stage prior to the anode. Configuration 2g included a reforming stage and was similar to configuration 2b and 2d, but operated with a fuel utilization of ~30%.

[00286] Three variations on the 2a configuration were simulated. The 2a simulation results shown in column 1310 were based on a configuration that included EGR, while the simulation results shown in column 1312 were based on a configuration that did not include EGR. The simulation results shown in column 1312 were based on a configuration that did not include EGR and an operating voltage of about 0.65 was maintained. In the simulations of column 1310 and 1312 an operating voltage of about 0.65 was maintained.

[00287] Recycling the anode output back to the anode input, as shown in Configuration 2a, resulted in a reduction of the required fuel cell area as compared to the relevant base case. In column 1310 the required fuel cell area was ~174 km², in column 1312 the required fuel cell area was ~169 km², and in column 1310 the required fuel cell area was ~131 km². As can be seen, the lowered voltage resulted in a lower fuel cell area.

[00288] The 2a configuration changed the CO₂ emissions from the cathode exhaust. In column 1310 the CO₂ emissions were ~141 lbs CO₂/MWhr, in column 1312 the CO₂ emissions were ~217.9 lbs CO₂/MWhr, and in column 1314, the CO₂ emissions were ~141 lbs CO₂/MWhr.

[00289] In Configuration 2b, a water gas shift reaction zone was included to process that anode outlet flow prior to water and carbon dioxide removal. Three variations on the 2b configuration were simulated. The 2b simulation results shown in column 1316 were based on a configuration that included EGR, while the simulation results shown in column 1318 were based on a configuration that did not include EGR. The simulation results shown in column 1320 were based on a configuration that did not include EGR and an operating voltage of about 0.65 was maintained. In the simulations of column 1316 and 1318 an operating voltage of about 0.65 was maintained.

[00290] In Configuration 2b, the additional water gas shift reaction zone increased the hydrogen content delivered to the anode, which reduced the amount of fuel needed for the anode reaction. Including the water gas shift reaction zone in Configuration 2b resulted in

a required fuel cell area of ~168 km² in column 1316, ~164 km² in column 1318, and ~129 km² in column 1320. The CO₂ loss from the cathode exhaust was ~143 lbs CO₂/MWhr in column 1316, was ~217.5 lbs CO₂/MWhr in column 1318, and was ~218.7 lbs CO₂/MWhr in column 1320. The area of fuel cell per megaton of CO₂ captured was ~101.1 km²*year/Mton-CO₂ in column 1316, was ~114.9 km²*year/Mton-CO₂ in column 1318, and was ~90.1 km²*year/Mton-CO₂ in column 1320.

[00291] Configuration 2c can take further advantage of the hydrogen content in the anode recycle by eliminating the reforming of fuel occurring prior to entering the anode. In Configuration 2c, reforming can still occur within the anode itself. However, in contrast to a conventional system incorporating a separate reforming stage prior to entry into the fuel cell anode, Configuration 2c relied on the hydrogen content of the recycled anode gas to provide the minimum hydrogen content for sustaining the anode reaction. Because a separate reforming stage was not required, the heat energy was not consumed to maintain the temperature of the reforming stage.

[00292] Four variations on the 2c configuration were simulated. The 2c simulation results shown in columns 1322 and 1324 were based on a configuration that included EGR, while the simulation results shown in columns 1326 and 1328 were based on a configuration that did not include EGR. The simulation results shown in columns 1322 and 1326 were based on a simulation where an operating voltage of about 0.70 was maintained. The simulation results shown in columns 1324 and 1328 were based on a simulation where an operating voltage of about 0.65 was maintained.

[00293] Configuration 2c resulted in a required fuel cell area of ~161 km² for column 1322, ~126 km² for column 1324, ~157 km² for column 1326, and ~126 km² for column 1328. The CO₂ loss from the cathode exhaust was ~142.5 lbs CO₂/MWhr for column 1322, ~143.5 lbs CO₂/MWhr for column 1324, ~223.7 lbs CO₂/MWhr for column 1326, and ~225.5 lbs CO₂/MWhr for column 1328.

[00294] In Configuration 2d, reforming was still performed to convert ~20% of the methane input to the anode into H₂ prior to entering the anode in similar arraignment to configuration 2b. In contrast with 2b, the fuel utilization within the anode was reduced from ~75% to ~50%.

[00295] Four variations on the 2d configuration were simulated. The 2d simulation results shown in columns 1330 and 1332 were based on a configuration that included EGR, while the simulation results shown in columns 1334 and 1336 were based on a configuration that did not include EGR. The simulation results shown in columns 1330 and 1334 were based on a simulation where an operating voltage of about 0.70 was maintained. The simulation results shown in columns 1332 and 1336 were based on a simulation where an operating voltage of about 0.65 was maintained.

[00296] Configuration 2e incorporated both the reduced fuel utilization of ~50% of 2d as well as elimination of the reforming stage prior to the anode inlet of 2c. Four variations on the 2e configuration were simulated. The 2e simulation results shown in columns 1338 and 1340 were based on a configuration that included EGR, while the simulation results shown in columns 1342 and 1344 were based on a configuration that did not include EGR. The simulation results shown in columns 1338 and 1342 were based on a simulation where an operating voltage of about 0.70 was maintained. The simulation results shown in columns 1340 and 1344 were based on a simulation where an operating voltage of about 0.65 was maintained.

[00297] In Configuration 2g (columns 1346, 1348), reforming was still performed to convert ~20% of the methane input to the anode into H₂ prior to entering the anode in similar arrangement to configuration 2b and 2d. In contrast with 2b and 2d, the fuel utilization within the anode was reduced from ~75% or ~50% to ~30%.

[00298] Column 1350 describes results of a simulation performed with a configuration similar to the configuration shown in FIG. 9. In FIG. 9, the EGR 998 first goes through the cathode and then HRSG 854. A base case simulation for this configuration was performed. The simulated results from the base case are shown in column 1309. In contrast to the base case, the simulated results of column 1350 were based on a fuel utilization of ~50% rather than ~75%. In addition, the simulated results of column 1350 were based on a configuration where reforming was still performed to convert ~20% of the methane input to the anode into H₂ prior to entering the anode in a similar arrangement to configuration 2b and 2d.

[00299] FIG. 14 shows results from simulations performed based on several configuration variants and alternative operating conditions. The simulations of FIG. 14 took into account

more factors than the simulations explained previously with reference FIG. 11. Otherwise, the simulations shown in FIG. 14 were similar to the simulations shown in FIG. 11, with a few variations added. For example, each case was simulated at about 0.65 volts in addition to the about 0.7 volts used in the FIG. 11 simulations. In addition, a case with 0% EGR was added to each configuration. FIG. 14 shows configurations corresponding to a base configuration (columns 1404, 1406, 1408) as well as several configurations where a portion of the anode output was recycled to the combustion zone for the turbine. Unless noted, the exhaust gas recycle was ~35% for the simulated results shown in FIG. 11. In FIG. 14, each configuration was run with either ~35% or 0% EGR as shown.

[00300] In addition to different configurations and alternative operating conditions, FIG. 14 shows additional parameters that were not shown in FIG. 11. For example, FIG. 14 includes the approximate fuel utilization, approximate steam to carbon ratio, EGR %, whether or not water gas shift reactors were present in the configuration to process the anode exhaust, the approximate internal reforming %, the approximate CO₂ concentration in the cathode inlet, and the approximate O₂ content in the cathode exhaust.

[00301] FIG. 14 shows simulation results for additional configurations that included recycle of at least a portion of the anode exhaust to the combustion zone for the turbine. In FIG. 14, Configuration 1b (column 1408) was similar to Configuration 1a (column 1406), but also included a water-gas shift reaction stage prior to the CO₂ separation stages. Thus, Configuration 1b was representative of a conventional system, such as the aforementioned Manzolini reference, with the exceptions that the Manzolini reference did not describe a water-gas shift reaction stage or recycle of exhaust gas. For the 1b configuration, the required fuel cell area to achieve a CO₂ concentration in the cathode exhaust of ~1.45% was ~197 km². The amount of CO₂ lost as part of the cathode exhaust was ~147 lbs CO₂/MWhr. The area of fuel cell per ton of CO₂ captured was ~107.6 km²*year/Mton-CO₂. The total power generated was ~609 MW. The electrical efficiency was ~52.1%.

[00302] Configurations 3a, 3b, and 3d correspond to configurations where the anode output was used as an input for the combustion zone of the turbine. In these configurations, the H₂ content of the anode output was available for use as a fuel in the turbine combustion zone. This appeared to be advantageous, as the carbon-containing fuel used to generate the

H₂ was generated in the anode recycle loop, where the majority of the resulting CO₂ can be removed via the cryogenic separation stages. This could also result in a reduction of the amount of carbon containing fuel delivered to the combustion zone, but the reduction in carbon-containing fuel in the combustion zone could also result in the reduction of the CO₂ concentration in the input to the cathode.

[00303] Configuration 3a was a configuration similar to Configuration 1a, but with recycle of the anode exhaust to the combustion zone. Four variations on the 3a configuration were simulated. The 3a simulation results shown in columns 1410 and 1412 were based on a configuration that included EGR, while the simulation results shown in columns 1414 and 1416 were based on a configuration that did not include EGR. The simulation results shown in columns 1410 and 1414 were based on a simulation where an operating voltage of about 0.70 was maintained. The simulation results shown in columns 1412 and 1416 were based on a simulation where an operating voltage of about 0.65 was maintained.

[00304] Column 1410 shows the simulated results produced from a configuration most similar to the 1a base case shown in column 1406. The required fuel cell area to achieve a CO₂ concentration in the cathode exhaust of ~1.45% was ~179 km². The amount of CO₂ lost as part of the cathode exhaust was ~150.4 lbs CO₂/MWhr. The area of fuel cell per ton of CO₂ captured was ~116.3 km²*year/Mton-CO₂. The total power generated was ~599 MW. The electrical efficiency was ~55.5%. Relative to Configuration 1a, Configuration 3a had a lower total amount of CO₂ captured (~1.88 Mtons/year for Configuration 1a vs. ~1.54 Mtons/year for Configuration 3a). This was believed to be due to the reduced amount of carbon-containing fuel delivered to the combustion zone. However, this also appeared to result in a reduced CO₂ concentration delivered to the cathode input, which caused the model to show a reduced efficiency of CO₂ removal for Configuration 3a. Configuration 3a appeared to have several advantages relative to Configuration 1a. First, Configuration 3a required a lower fuel cell area, so that the system in Configuration 3a would likely have a reduced cost. Additionally, the system in Configuration 3a appeared to have improved electrical efficiency, which can indicate lower fuel usage, even after adjusting for the different power output of the configurations.

[00305] Configuration 3b was similar to Configuration 3a, but also included a water gas shift reaction zone prior to the cryogenic separation stages. Four variations on the 3b configuration were simulated. The 3b simulation results shown in columns 1418 and 1420 were based on a configuration that included EGR, while the simulation results shown in columns 1422 and 1424 were based on a configuration that did not include EGR. The simulation results shown in columns 1418 and 1422 were based on a simulation where an operating voltage of about 0.70 was maintained. The simulation results shown in columns 1420 and 1424 were based on a simulation where an operating voltage of about 0.65 was maintained.

[00306] As with the simulations shown in FIG.11, configuration 3b appeared to have increased CO₂ emission via the cathode exhaust. This was believed to be due to the additional hydrogen delivered to the combustion zone, which can result in a corresponding reduction in the amount of CO₂ the combustion exhaust used for the cathode input. However, the fuel cell area was further reduced.

[00307] Configuration 3d was similar to Configuration 3b, but the anode fuel utilization was reduced from ~75% to ~50%. Four variations on the 3d configuration were simulated. The 3d simulation results shown in columns 1426 and 1428 were based on a configuration that included EGR, while the simulation results shown in columns 1430 and 1432 were based on a configuration that did not include EGR. The simulation results shown in columns 1426 and 1430 were based on a simulation where an operating voltage of about 0.70 was maintained. The simulation results shown in columns 1428 and 1432 were based on a simulation where an operating voltage of about 0.65 was maintained.

[00308] Configuration 3g (column 1434) was similar to Configuration 3b, but the anode fuel utilization was reduced from ~75% to ~30%.

[00309] Column 1436 describes results of a simulation performed with a configuration similar to the configuration shown in FIG. 9. In FIG. 9, the EGR 998 first goes through the cathode and then HRSG 854. A base case 1a' simulation for this configuration was performed. The simulated results from the base case 1a' are shown in column 1309 in FIG. 13. In contrast to the base case, the simulated results of column 1436 were based on a fuel utilization of ~50% rather than ~75%. In addition, the simulated results of column 1436

were based on a configuration where reforming was still performed to convert ~20% of the methane input to the anode into H₂ prior to entering the anode in a similar arrangement to configuration 3b and 3d.

[00310] FIG. 15 shows results from simulations performed based on several configuration variants and alternative operating conditions (base configuration (columns 1504, 1506, 1508); Configuration 4d (columns 1510, 1512, 1514, 1516, 1518); Configuration 4e columns (1520, 1522, 1524, 1526, 1528); and Configuration 4f (columns 1530, 1532, 1534, 1536)). The simulations of FIG. 15 took into account more factors than the simulations explained previously with reference FIG. 12. Configurations 4d and 4e represent configurations where the remaining anode exhaust after separation (removal) of CO₂ and H₂O was divided evenly between recycle to the anode input and recycle to the combustion zone for the turbine. In order to provide sufficient hydrogen for both the anode input and the combustion zone, the anode fuel utilization in Configurations 4d and 4e was set to ~50%. Configurations 4d and 4e both included a water gas shift reaction zone prior to the separation stages. Configuration 4d included a separate reforming stage for reforming ~20% of the additional fuel input to the anode prior to the fuel entering the anode. Configuration 4e did not include a reforming stage prior to the fuel entering the anode input.

[00311] Four variations on the 4d configuration were simulated. The 4d simulation results shown in columns 1510 and 1512 were based on a configuration that included EGR, while the simulation results shown in columns 1514 and 1516 were based on a configuration that did not include EGR. The simulation results shown in columns 1510 and 1514 were based on a simulation where an operating voltage of about 0.70 was maintained. The simulation results shown in columns 1512 and 1516 were based on a simulation where an operating voltage of about 0.65 was maintained.

[00312] Five variations on the 4e configuration were simulated. The 4e simulation results shown in columns 1520 and 1522 were based on a configuration that included about a 35% EGR, while the simulation results shown in columns 1524 and 1526 were based on a configuration that did not include EGR. The 4e simulation of column 1528 was a configuration that included about a 45% EGR. The simulation results shown in columns 1520, 1524, and 1528 were based on a simulation where an operating voltage of about 0.70

was maintained. The simulation results shown in columns 1522 and 1526 were based on a simulation where an operating voltage of about 0.65 was maintained.

[00313] Configuration 4f was similar to Configuration 4e, with the exception that the anode fuel utilization in Configuration 4f was ~33%, as opposed to the ~50% in Configuration 4e. Four variations on the 4e configuration were simulated. The 4f simulation results shown in columns 1530 and 1532 were based on a configuration that included about a 35% EGR, while the simulation results shown in columns 1534 and 1536 were based on a configuration that did not include EGR. The simulation results shown in columns 1530 and 1534 were based on a simulation where an operating voltage of about 0.70 was maintained. The simulation results shown in columns 1532 and 1536 were based on a simulation where an operating voltage of about 0.65 was maintained.

[00314] Column 1538 describes results of a simulation performed with a configuration similar to the configuration shown in FIG. 9. In FIG. 9, the EGR 998 first goes through the cathode and then HRSG 854. A base case 1a' simulation for this configuration was performed. The simulated results from the base case 1a' are shown in column 1309 in FIG. 13. In contrast to the base case, the simulated results of column 1538 were based on a fuel utilization of ~50% rather than ~75%. In addition, the simulated results of column 1538 were based on a configuration where reforming was still performed to convert ~20% of the methane input to the anode into H₂ prior to entering the anode in a similar arrangement to configuration 4b and 4d.

[00315] Although the present invention has been described in terms of specific embodiments, it is not so limited. Suitable alterations/modifications for operation under specific conditions should be apparent to those skilled in the art. It is therefore intended that the following claims be interpreted as covering all such alterations/modifications as fall within the true spirit/scope of the invention.

CLAIMS:

1. A method for capturing carbon dioxide from a combustion source, the method comprising:

introducing a fuel stream and an O₂-containing stream into a combustion zone;

performing a combustion reaction in the combustion zone to generate a combustion exhaust, the combustion exhaust comprising CO₂;

processing a cathode inlet stream, the cathode inlet stream comprising at least a first portion of the combustion exhaust, with a fuel cell array of one or more molten carbonate fuel cells to form a cathode exhaust stream from at least one cathode outlet of the fuel cell array, the one or more molten carbonate fuel cells comprising one or more fuel cell anodes and one or more fuel cell cathodes, the one or more molten carbonate fuel cells being operatively connected to the combustion zone through at least one cathode inlet;

reacting carbonate from the one or more fuel cell cathodes with H₂ within the one or more fuel cell anodes to produce electricity and an anode exhaust stream from at least one anode outlet of the fuel cell array, the anode exhaust stream comprising CO₂ and H₂;

separating CO₂ from the anode exhaust stream in one or more separation stages to form a CO₂-depleted anode exhaust stream;

passing at least a combustion-recycle portion of the CO₂-depleted anode exhaust stream to the combustion zone; and

recycling at least an anode-recycle portion of the CO₂-depleted anode exhaust stream to the one or more fuel cell anodes;

wherein a fuel utilization in the one or more fuel cell anodes is 65% or less, and

wherein the fuel utilization is the ratio of the amount of hydrogen oxidized in the anode for production of electricity versus a reformable hydrogen content of an anode input, wherein reformable hydrogen content of a fuel is the number of H₂ molecules that can be derived from a fuel by reforming the fuel and then driving a water gas shift reaction to completion to maximize H₂ production.

2. The method of claim 1, wherein the fuel utilization in the one or more fuel cell anodes is 60% or less.
3. The method of claim 2, wherein the fuel utilization in the one or more fuel cell anodes is 30% to 50%.
4. The method of claim 2, wherein the one or more fuel cell anodes comprise a plurality of anode stages and the one or more fuel cell cathodes comprise a plurality of cathode stages, wherein a low utilization anode stage in the plurality of anode stages has an anode fuel utilization of 65% or less, the low utilization anode stage corresponding to high utilization cathode stage of the plurality of cathode stages, the high utilization cathode stage having a CO₂ content at a cathode inlet as high as or higher than a CO₂ at a cathode inlet of any other cathode stage of the plurality of cathode stages.
5. The method of claim 4, wherein the fuel utilization in the low utilization anode stage is at least 40%.
6. The method of claim 4, wherein the fuel utilization in each anode stage of the plurality of anode stages is 60% or less.
7. The method of any one of claims 1 to 6, wherein the combustion-recycle portion of the CO₂-depleted anode exhaust stream comprises at least 25% of the CO₂-depleted anode exhaust stream, and wherein the anode-recycle portion of the CO₂-depleted anode exhaust stream comprises at least 25% of the CO₂-depleted anode exhaust stream.
8. The method of claim 7, further comprising passing carbon-containing fuel into the one or more fuel cell anodes, the carbon-containing fuel optionally comprising CH₄.

9. The method of claim 8, further comprising:
reforming at least a portion of the carbon-containing fuel to generate H₂; and
passing at least a portion of the generated H₂ into the one or more fuel cell anodes.
10. The method of claim 8, wherein the carbon-containing fuel is passed into the one or more fuel cell anodes without passing the carbon-containing fuel into a reforming stage prior to entering the one or more fuel cell anodes.
11. The method of any one of claims 1 to 10, wherein the combustion exhaust comprises 10 vol% or less of CO₂, the combustion exhaust optionally comprising at least 4 vol% of CO₂.
12. The method of any one of claims 1 to 11, further comprising recycling a second portion of the combustion exhaust to the combustion zone, the second portion of the combustion exhaust optionally comprising at least 6 vol% CO₂.
13. The method of claim 12, wherein recycling the second portion of the combustion exhaust to the combustion zone comprises:
exchanging heat between the second portion of the combustion exhaust and an H₂O-containing stream to form steam;
separating water from the second portion of the combustion exhaust to form an H₂O-depleted combustion exhaust stream; and
passing at least a portion of the H₂O-depleted combustion exhaust into the combustion zone.
14. The method of any one of claims 1 to 13, wherein the anode exhaust stream, prior to the separating CO₂ from the anode exhaust stream in one or more separation stages, comprises at least 5.0 vol% of H₂.

15. The method of any one of claims 1 to 14, further comprising exposing the anode exhaust stream to a water gas shift catalyst to form a shifted anode exhaust stream prior to the separating CO₂ from the anode exhaust stream in one or more separation stages, a H₂ content of the shifted anode exhaust stream after exposure to the water gas shift catalyst being greater than a H₂ content of the anode exhaust stream prior to exposure to the water gas shift catalyst.

16. The method of any one of claims 1 to 15, wherein the combustion-recycle portion of the CO₂-depleted anode exhaust stream is combined with the fuel stream prior to passing the combustion-recycle portion of the CO₂-depleted anode exhaust stream to the combustion zone.

17. The method of any one of claims 1 to 16, wherein the cathode exhaust stream has a CO₂ content of 2.0 vol% or less.

18. The method of any one of claims 1 to 17, wherein separating CO₂ from the anode exhaust stream in one or more separation stages comprises:

optionally separating water from the anode exhaust stream to form an optionally H₂O-depleted anode exhaust stream; and

cooling the optionally H₂O-depleted anode exhaust stream to form a condensed phase of CO₂.

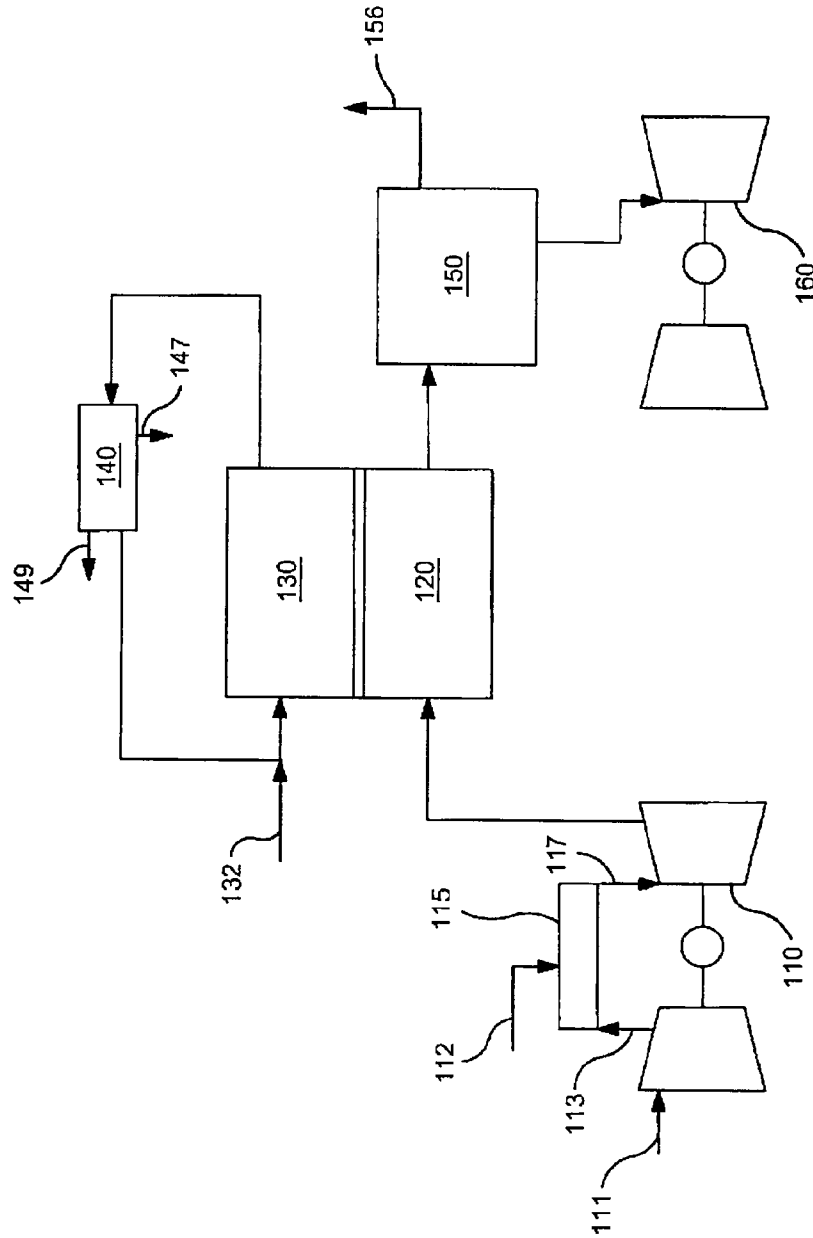

FIG. 1

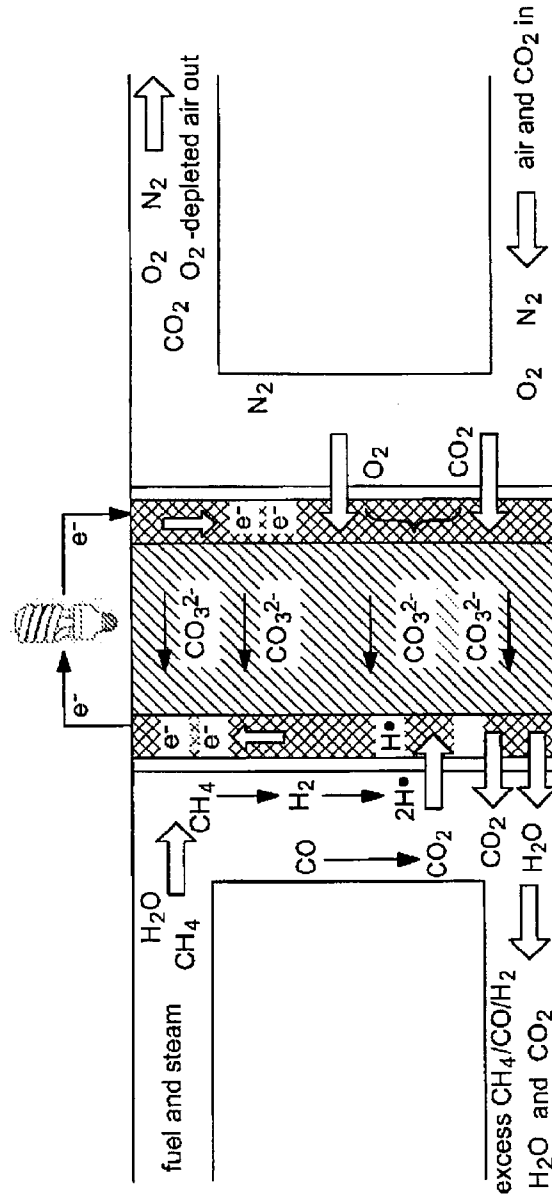

FIG. 2

3/20

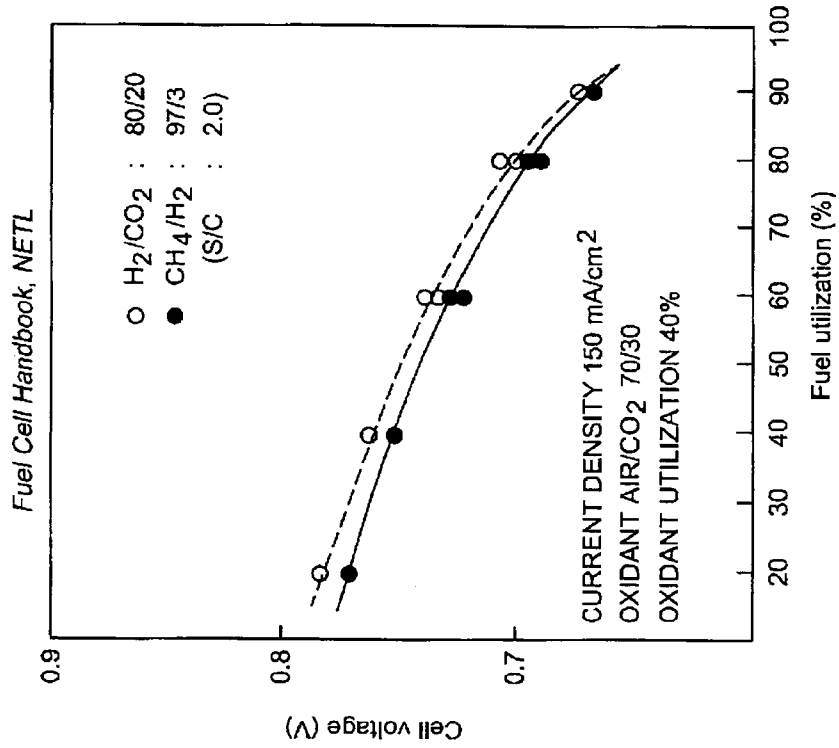

FIG. 3

4/20

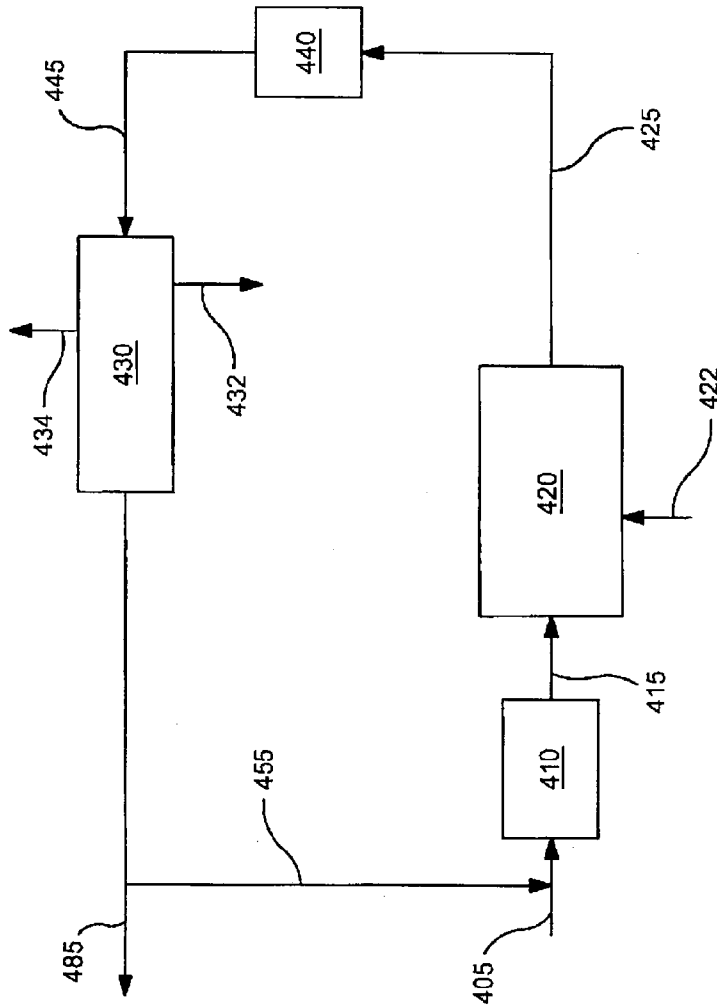

FIG. 4

5/20

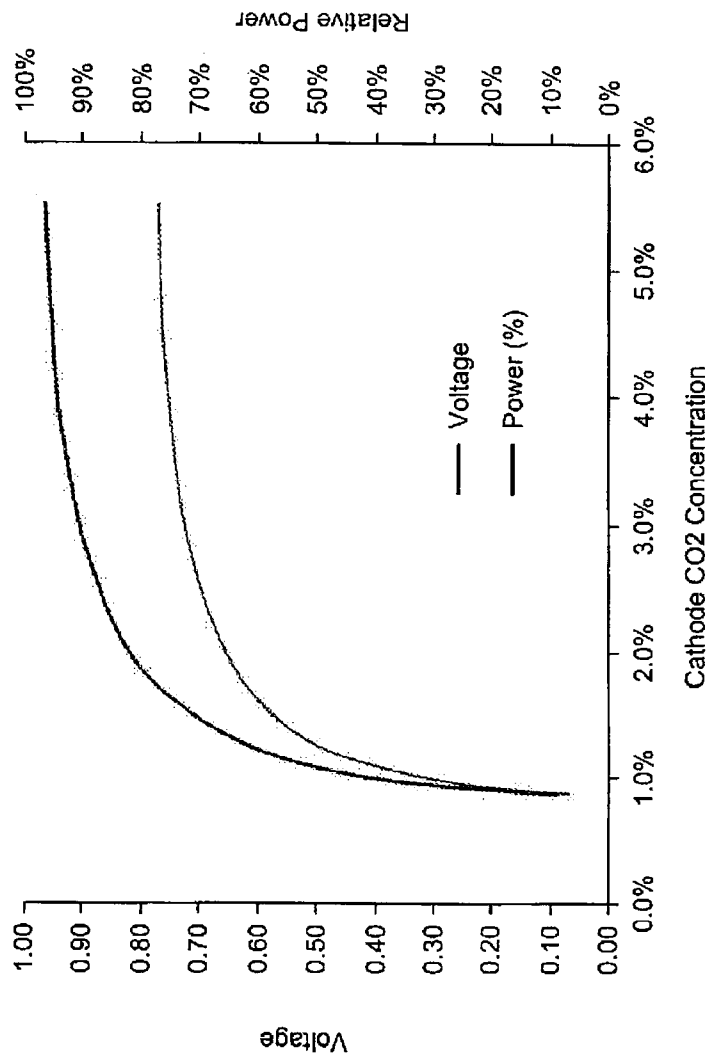

FIG. 5

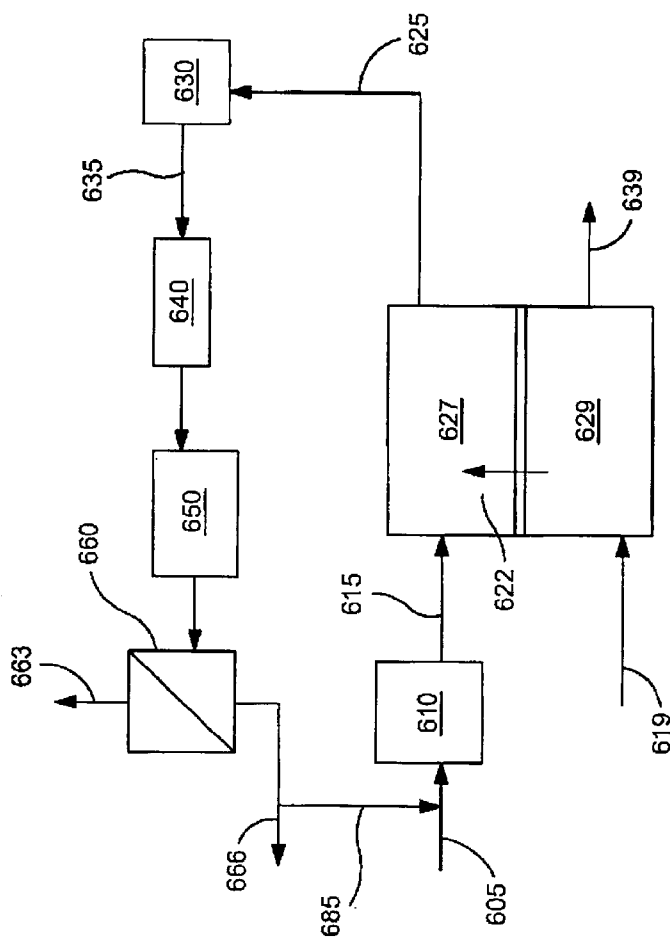

FIG. 6

7/20

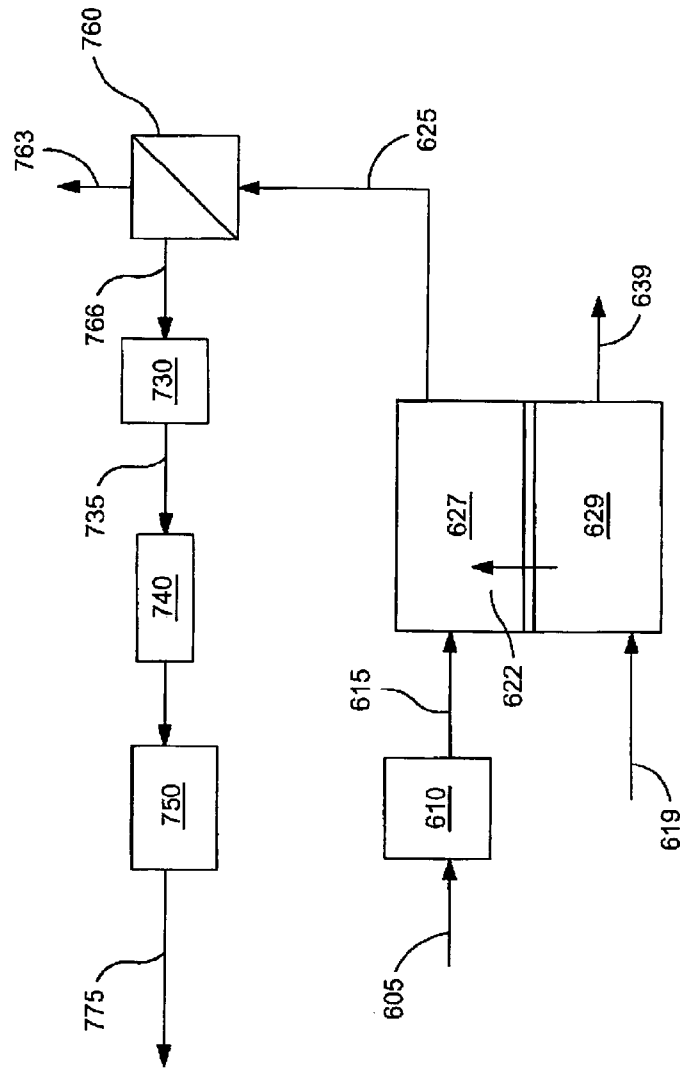

FIG. 7

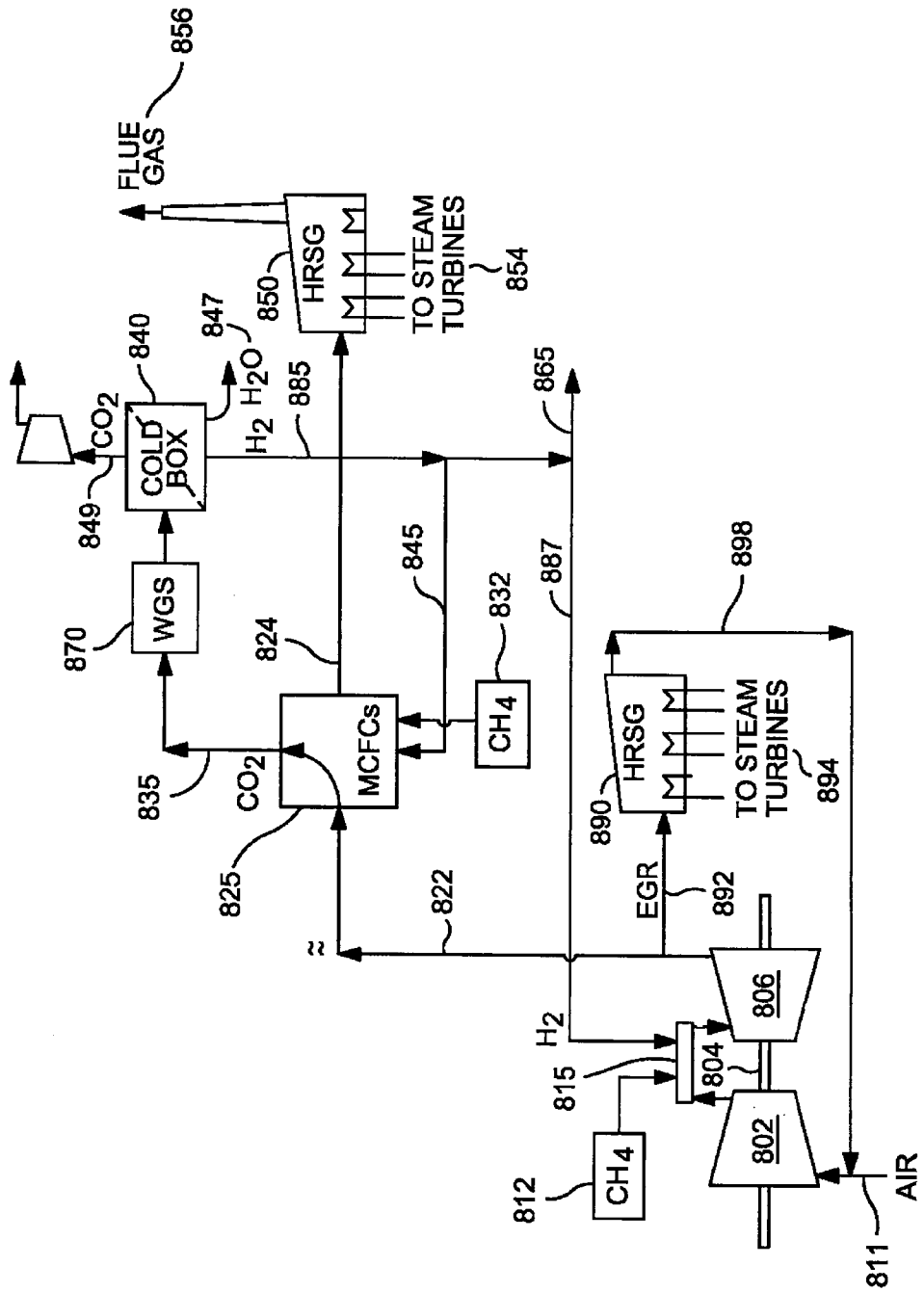

FIG. 8

13/20

Case	BASE CASES				CONCEPT 1: ANODE RECYCLE ...								
	0	1a	1b	1a'	2a	2a	2a	2a	2a	2b	2b	2b	2b
Fuel Utilization (%)	75%	75%	75%	75%	75%	75%	75%	75%	75%	75%	75%	75%	75%
Steam to Carbon Ratio	3.6	3.6	3.6	3.6	2.0	2.0	2.0	2.0	2.0	2.0	2.0	2.0	2.0
Exhaust Gas Recycle (%)	0%	35%	35%	35%	35%	0%	0%	0%	0%	35%	0%	0%	0%
Water Gas Shift Reactors	No	No	Yes	No	No	No	No	No	No	Yes	Yes	Yes	Yes
Internal Reforming (%)	99%	99%	99%	99%	20%	20%	20%	20%	20%	20%	20%	20%	20%
MCFC CO2 Cathode Inlet Conc. (%)	4.80%	7.36%	6.87%	5.31%	6.11%	4.05%	4.05%	4.05%	4.05%	6.13%	4.07%	4.07%	4.07%
MCFC CO2 Cathode Exhaust Conc. (%)	1.5%	1.5%	1.5%	1.5%	1.5%	1.5%	1.5%	1.5%	1.5%	1.5%	1.5%	1.5%	1.5%
MCFC O2 Cathode Exhaust Conc. (%)	10.0%	4.2%	4.5%	4.8%	5.9%	10.9%	10.9%	10.9%	10.9%	5.8%	10.9%	10.9%	10.9%
MCFC Voltage (V)	0.70	0.70	0.70	0.70	0.70	0.70	0.70	0.65	0.70	0.70	0.70	0.70	0.65
MCFC Current Density (A/m2)	1015	1007	1000	915	961	847	1089	999	878	168	164	129	1120
MCFC Area (k-m2)	184	215	197	236	174	169	131	1089	999	878	164	129	1120
CO2 Capture (%)	72.5%	83.2%	82.6%	82.6%	71.0%	60.7%	60.5%	81.2%	70.2%	70.2%	70.2%	70.1%	70.1%
CO2 Capture (Mtons/year)	1.62	1.88	1.84	1.88	1.64	1.41	1.40	1.67	1.43	1.43	1.43	1.43	1.43
Area/Tons captured (k-m2*year/Mtons)	113.9	114.2	107.6	126.0	106.0	119.9	93.6	101.1	114.9	90.1	90.1	90.1	90.1
CO2 emissions (from cathode exhaust, lbs CO2/MW/hr)	212.0	145.7	147.5	134.8	141.9	217.9	218.8	143.4	217.5	218.7	218.7	218.7	218.7
Ratio H2:Reformable C (molar) in anode feed	0.00	0.00	0.00	0.00	0.80	0.81	0.80	1.30	1.30	1.30	1.30	1.30	1.30
N2 in anode feed (%)	0%	0%	0%	0%	0%	0%	0%	0%	0%	0%	0%	0%	0%
Anode steam penalty (MW)	10.4	12.0	11.0	12.0	4.0	3.4	3.4	3.9	3.4	3.4	3.4	3.4	3.4
% turbine fuel that is H2 or CO (LHV basis)	0.0%	0.0%	0.0%	0.0%	0.0%	0.0%	0.0%	0.0%	0.0%	0.0%	0.0%	0.0%	0.0%
Total net power (MW)	679	611	609	688	630	654	652	624	651	648	648	648	648
Electrical efficiency (%)	57.6%	51.2%	52.1%	57.3%	58.6%	61.3%	61.1%	57.9%	60.8%	60.5%	60.5%	60.5%	60.5%

FIG. 13

14/20

... CONCEPT 1: ANODE RECYCLE												EGR		
2c	2c	2c	2d	2d	2e	2e	2e	2e	2e	2g	2g	2g	EGR	
75%	75%	75%	50%	50%	50%	50%	50%	50%	50%	30%	30%	30%	50%	
0.0	0.0	0.0	2.0	2.0	0.0	0.0	0.0	0.0	0.0	2.0	2.0	2.0	2.0	
35%	0%	0%	35%	0%	35%	0%	35%	0%	0%	35%	35%	35%	35%	
Yes	Yes	Yes	Yes	Yes	Yes	Yes	Yes	Yes	Yes	Yes	Yes	Yes	Yes	
0%	0%	0%	20%	20%	0%	0%	0%	0%	0%	20%	20%	20%	20%	
6.13%	4.07%	4.07%	6.13%	4.07%	6.13%	4.07%	6.13%	4.07%	4.07%	6.53%	6.47%	6.47%	4.48%	
1.5%	1.5%	1.5%	1.5%	1.5%	1.5%	1.5%	1.5%	1.5%	1.5%	1.5%	1.5%	1.5%	1.5%	
5.8%	10.9%	10.9%	5.8%	10.9%	5.8%	10.9%	5.8%	10.9%	10.9%	4.8%	4.9%	4.9%	6.2%	
0.70	0.65	0.70	0.65	0.70	0.65	0.70	0.65	0.70	0.65	0.70	0.65	0.70	0.70	
1045	1329	919	1147	1093	1376	984	1218	1138	1414	1020	1246	1318	1603	
161	126	157	126	154	122	147	118	148	119	141	115	140	114	
81.1%	70.2%	70.1%	81.3%	81.3%	81.3%	70.1%	70.0%	80.9%	81.1%	69.8%	69.8%	82.6%	80.7%	
1.66	1.43	1.43	1.67	1.67	1.67	1.43	1.43	1.66	1.66	1.42	1.42	1.82	1.80	
96.6	76.0	109.6	88.0	92.5	73.4	102.7	82.9	89.0	71.6	99.1	81.2	77.0	63.3	
142.5	143.5	223.7	225.5	146.0	146.5	230.6	231.7	147.0	146.6	213.2	232.3	144.0	145.0	
1.28	1.28	1.28	3.80	3.80	3.80	3.80	3.80	3.62	3.64	3.64	3.64	8.58	8.59	
0%	0%	0%	0%	0%	0%	0%	0%	0%	0%	0%	0%	0%	0%	
0.0	0.0	0.0	3.9	3.9	3.4	3.4	3.4	0.0	0.0	0.0	0.0	4.3	4.2	
0.0%	0.0%	0.0%	0.0%	0.0%	0.0%	0.0%	0.0%	0.0%	0.0%	0.0%	0.0%	0.0%	0.0%	
630	627	633	630	611	607	617	614	615	612	621	617	617	609	
58.5%	58.2%	59.1%	58.8%	56.7%	56.4%	57.6%	57.3%	57.1%	56.8%	58.0%	57.6%	53.3%	53.1%	
1322	1324	1326	1328	1330	1332	1334	1336	1338	1340	1342	1344	1346	1348	
													1350	

FIG. 13
CONTINUED

15/20

Case	BASE CASES			CONCEPT 2: RECYCLE					
	0	1a	1b	3a	3a	3a	3a	3a	3a
Fuel Utilization (%)	75%	75%	75%	75%	75%	75%	75%	75%	75%
Steam to Carbon Ratio	3.6	3.6	3.6	2.0	2.0	2.0	2.0	2.0	2.0
Exhaust Gas Recycle (%)	0%	35%	35%	35%	35%	35%	35%	0%	0%
Water Gas Shift Reactors	No	No	Yes	No	No	No	No	No	No
Internal Reforming (%)	99%	99%	99%	99%	99%	20%	20%	20%	20%
MCFC CO2 Cathode Inlet Conc. (%)	4.80%	7.36%	6.87%	5.87%	5.87%	5.87%	3.92%	3.92%	3.92%
MCFC CO2 Cathode Exhaust Conc. (%)	1.5%	1.5%	1.5%	1.5%	1.5%	1.5%	1.5%	1.5%	1.5%
MCFC O2 Cathode Exhaust Conc. (%)	10.0%	4.2%	4.5%	6.1%	6.1%	6.1%	11.0%	11.0%	11.0%
MCFC Voltage (V)	0.70	0.70	0.70	0.70	0.70	0.65	0.70	0.65	0.65
MCFC Current Density (A/m2)	1015	1007	1000	889	1176	793	1029	1029	1029
MCFC Area (k-m2)	184	215	197	179	135	171	132	132	132
CO2 Capture (%)	72.5%	83.2%	82.6%	80.9%	80.9%	80.9%	70.3%	70.3%	70.3%
CO2 Capture (Mtons/year)	1.62	1.88	1.84	1.54	1.54	1.54	1.32	1.32	1.32
Area/Tons captured (k-m2*year/Mtons)	113.9	114.2	107.6	116.3	87.9	129.5	99.7	99.7	99.7
CO2 emissions (from cathode exhaust, lbs CO2/MWhr)	212.0	145.7	147.5	150.4	151.4	236.9	238.1	238.1	238.1
Ratio H2:Reformable C (molar) in anode feed	0.00	0.00	0.00	0.00	0.00	0.80	0.81	0.80	0.80
N2 in anode feed (%)	0%	0%	0%	0%	0%	0%	0%	0%	0%
Anode steam penalty (MW)	10.4	12.0	11.0	5.0	5.0	4.2	4.2	4.2	4.2
% turbine fuel that is H2 or CO (LHV basis)	0.0%	0.0%	0.0%	0.0%	0.0%	0.0%	0.0%	0.0%	0.0%
Total net power (MW)	679	611	609	599	599	596	603	601	601
Electrical efficiency (%)	57.6%	51.2%	52.1%	55.5%	55.2%	56.5%	56.2%	56.2%	56.2%

FIG. 14

16/20

CONCEPT 2: RECYCLE TO CTG												EGR
3b	3b	3b	3b	3d	3d	3d	3d	3d	3d	3d	3g	EGR
75%	75%	75%	75%	50%	50%	50%	50%	50%	50%	50%	30%	50%
2.0	2.0	2.0	2.0	2.0	2.0	2.0	2.0	2.0	2.0	2.0	2.0	2.0
35%	0%	0%	0%	35%	35%	0%	0%	0%	0%	0%	35%	35%
Yes	Yes	Yes	Yes	Yes	Yes	Yes	Yes	Yes	Yes	Yes	Yes	Yes
20%	20%	20%	20%	20%	20%	20%	20%	20%	20%	20%	20%	20%
5.72%	3.83%	3.83%	5.12%	5.12%	5.12%	3.50%	3.50%	3.50%	3.50%	4.53%	3.83%	3.83%
1.5%	1.5%	1.5%	1.5%	1.5%	1.5%	1.5%	1.5%	1.5%	1.5%	1.5%	1.5%	1.5%
6.2%	11.1%	11.1%	6.6%	6.6%	6.6%	11.2%	11.2%	11.2%	11.2%	6.5%	6.9%	6.9%
0.70	0.65	0.70	0.65	0.70	0.65	0.70	0.65	0.70	0.65	0.70	0.70	0.70
878	1161	784	1018	916	1164	846	1053	1050	1050	800	800	800
175	132	167	128	144	113	133	107	106	106	165	165	165
80.7%	80.7%	69.0%	69.0%	80.0%	79.5%	68.5%	68.5%	80.2%	80.2%	79.8%	79.8%	79.8%
1.62	1.62	1.38	1.38	1.55	1.54	1.32	1.32	1.32	1.32	1.57	1.55	1.55
108.0	81.7	121.0	93.2	93.1	73.5	100.8	80.8	67.8	67.8	106.3	106.3	106.3
147.8	148.6	234.9	235.8	160.2	162.5	247.2	248.2	186.1	186.1	165.0	165.0	165.0
0.00	0.00	0.00	0.00	0.00	0.00	0.00	0.00	0.00	0.00	0.00	0.00	0.00
0%	0%	0%	0%	0%	0%	0%	0%	0%	0%	0%	0%	0%
4.8	4.8	4.1	4.1	6.2	6.1	5.3	5.3	8.7	8.7	6.2	6.2	6.2
6.6%	6.6%	5.5%	5.5%	16.4%	16.5%	13.9%	13.9%	32.1%	32.1%	16.5%	16.5%	16.5%
610	607	613	610	571	570	581	580	501	501	568	568	568
57.7%	57.4%	58.3%	58.1%	55.4%	55.4%	56.5%	56.4%	47.2%	47.2%	54.8%	54.8%	54.8%

FIG. 14
CONTINUED

17/20

Case	BASE CASES				CONCEPT 4B: HIGH INERTS CASES ...			
	0	1a	1b	4d	4d	4d	4d	4d
Fuel Utilization (%)	75%	75%	75%	50%	50%	50%	50%	50%
Steam to Carbon Ratio	3.6	3.6	3.6	2.0	2.0	2.0	2.0	2.0
Exhaust Gas Recycle (%)	0%	35%	35%	35%	35%	0%	0%	45%
Water Gas Shift Reactors	No	No	Yes	Yes	Yes	Yes	Yes	Yes
Internal Reforming (%)	99%	99%	99%	20%	20%	20%	20%	20%
MCFC CO2 Cathode Inlet Conc. (%)	4.80%	7.36%	6.87%	5.56%	5.56%	3.75%	3.76%	6.50%
MCFC CO2 Cathode Exhaust Conc. (%)	1.5%	1.5%	1.5%	1.5%	1.5%	1.5%	1.5%	1.5%
MCFC O2 Cathode Exhaust Conc. (%)	10.0%	4.2%	4.5%	6.3%	6.3%	11.1%	11.1%	3.8%
MCFC Voltage (V)	0.70	0.70	0.70	0.70	0.65	0.70	0.65	0.70
MCFC Current Density (A/m2)	1015	1007	1000	1096	1364	990	1211	1080
MCFC Area (k-m2)	184	215	197	135	108	128	104	142
CO2 Capture (%)	72.5%	83.2%	82.6%	80.5%	80.4%	69.7%	69.2%	83.9%
CO2 Capture (Mtons/year)	1.62	1.88	1.84	1.60	1.60	1.38	1.37	1.66
Area/Tons captured (k-m2*year/Mtons)	113.9	114.2	107.6	84.1	67.7	92.8	76.1	85.3
CO2 emissions (from cathode exhaust, lbs CO2/MW*hr)	212.0	145.7	147.5	154.7	156.3	229.6	233.3	128.6
Ratio H2:Reformable C (molar) in anode feed	0.00	0.00	0.00	1.18	1.19	1.20	1.19	1.18
N2 in anode feed (%)	0%	0%	0%	0%	0%	0%	0%	0%
Anode steam penalty (MW)	10.4	12.0	11.0	5.3	5.3	4.6	4.6	5.5
% turbine fuel that is H2 or CO (LHV basis)	0.0%	0.0%	0.0%	9.3%	9.3%	7.9%	7.8%	9.8%
Total net power (MW)	679	611	609	587	584	618	616	580
Electrical efficiency (%)	57.6%	51.2%	52.1%	55.5%	55.3%	58.6%	58.4%	55.1%

1504 1506 1508 1510 1512 1514 1516 1518

FIG. 15

18/20

... CONCEPT 4B: HIGH INERTS CASES											EGR	
4e	4e	4e	4e	4e	4e	4f	4f	4f	4f	4f	4f	4f
50%	50%	50%	50%	50%	50%	33%	33%	33%	33%	33%	33%	50%
1.0	1.0	1.0	1.0	1.0	1.0	1.0	1.0	1.0	1.0	1.0	1.0	2.0
35%	0%	0%	0%	45%	35%	35%	35%	0%	0%	0%	0%	35%
Yes	Yes	Yes	Yes	Yes	Yes	Yes	Yes	Yes	Yes	Yes	Yes	Yes
0%	0%	0%	0%	0%	0%	0%	0%	0%	0%	0%	0%	0%
5.57%	5.57%	3.76%	3.76%	6.51%	6.46%	6.47%	6.47%	4.99%	4.99%	4.99%	4.99%	4.13%
1.5%	1.5%	1.5%	1.5%	1.5%	1.5%	1.5%	1.5%	1.5%	1.5%	1.5%	1.5%	1.5%
6.3%	6.3%	11.1%	11.1%	3.8%	4.8%	4.8%	4.8%	4.8%	4.8%	4.8%	4.8%	6.6%
0.70	0.65	0.70	0.65	0.70	0.70	0.70	0.65	0.65	0.70	0.65	0.70	0.70
1104	1372	999	1214	1094	1362	1682	1682	1227	1509	1509	950	950
134	108	127	105	141	133	108	160	130	156	130	156	156
80.8%	80.8%	69.3%	69.3%	83.9%	82.3%	82.2%	82.2%	73.1%	73.0%	73.0%	79.9%	79.9%
1.60	1.60	1.37	1.37	1.65	1.74	1.75	1.63	1.63	1.63	1.63	1.60	1.60
84.1	67.7	93.1	76.6	85.0	76.0	61.6	97.6	79.7	79.7	79.7	97.2	97.2
152.8	153.8	232.0	231.9	128.8	148.3	150.1	217.5	217.3	158.1	217.3	158.1	158.1
1.17	1.17	1.17	1.17	1.17	1.79	1.81	1.80	1.81	1.81	1.80	1.81	1.18
0%	0%	0%	0%	0%	0%	0%	0%	0%	0%	0%	0%	0%
2.7	2.7	2.3	2.3	2.8	4.3	4.3	4.7	4.7	4.7	4.7	5.3	5.3
9.3%	9.3%	7.7%	7.8%	9.7%	24.0%	24.2%	25.6%	25.7%	25.7%	25.7%	9.2%	9.2%
589	586	620	618	584	602	598	654	654	652	652	595	595
55.6%	55.3%	58.7%	58.5%	55.2%	53.1%	56.2%	54.9%	54.6%	54.6%	54.6%	55.9%	55.9%
1520	1522	1524	1526	1528	1530	1532	1534	1536	1538	1538	1538	1538

FIG. 15
CONTINUED

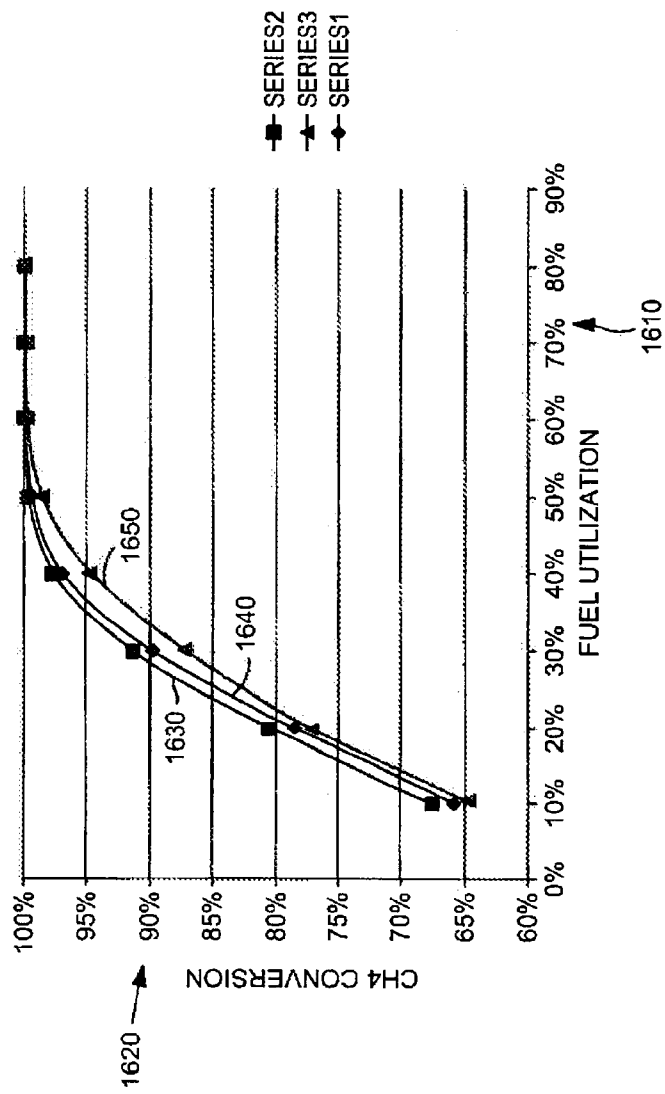

FIG. 16

20/20

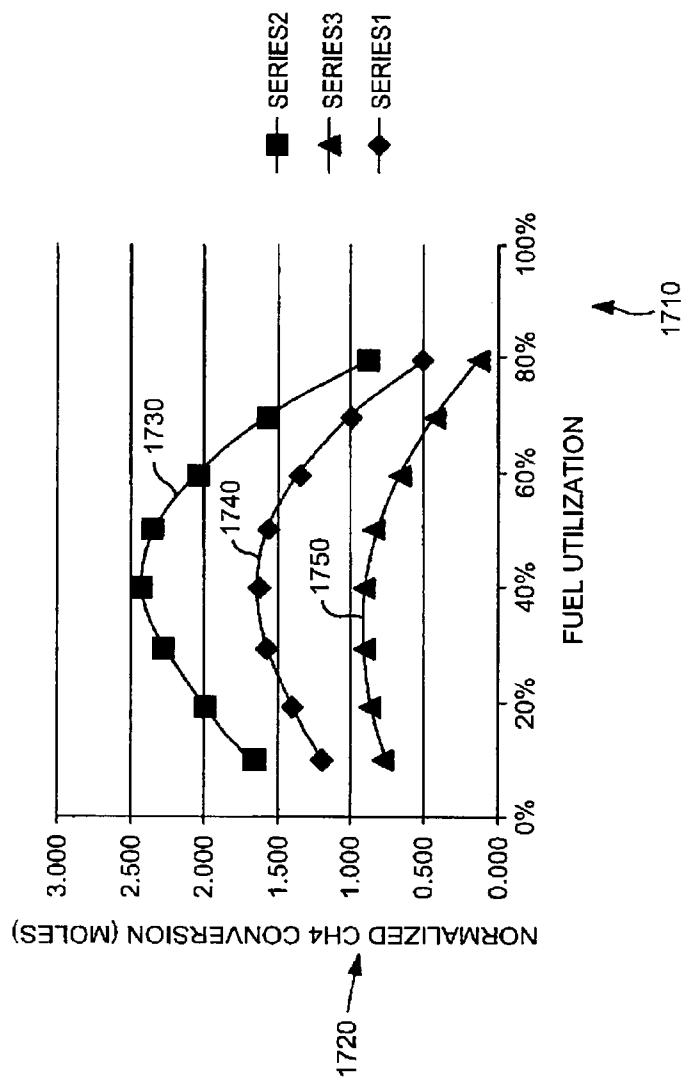

FIG. 17

