

(19) World Intellectual Property Organization
International Bureau



(43) International Publication Date
9 April 2009 (09.04.2009)

PCT

(10) International Publication Number
WO 2009/043872 A1

(51) International Patent Classification:

A61L 29/14 (2006.01) A61M 25/00 (2006.01)
A61L 29/16 (2006.01)

(21) International Application Number:

PCT/EP2008/063143

(22) International Filing Date: 1 October 2008 (01.10.2008)

(25) Filing Language: English

(26) Publication Language: English

(30) Priority Data:

07117801.6 3 October 2007 (03.10.2007) EP
60/960,556 3 October 2007 (03.10.2007) US

(71) Applicant (for all designated States except US): **ASTRA
TECH AB** [SE/SE]; Aminogatan 1, S-431 21 Mölndal
(SE).

(72) Inventors; and

(75) Inventors/Applicants (for US only): **NORDHOLM, Ag-
neta** [SE/SE]; Lindsvägen 1, S-433 51 Öjersjö (SE). **NY-
MAN, Martin** [SE/SE]; Heljereds Byväg 57, S-428 36

Källered (SE). **HOLM, Daniel** [SE/SE]; Öjersjövägen 3,
S-433 50 Öjersjö (SE).

(74) Agent: **LIND, Urban**; Awapatent AB, P.O. Box 11394,
S-404 28 Göteborg (SE).

(81) Designated States (unless otherwise indicated, for every
kind of national protection available): AE, AG, AL, AM,
AO, AT, AU, AZ, BA, BB, BG, BH, BR, BW, BY, BZ, CA,
CH, CN, CO, CR, CU, CZ, DE, DK, DM, DO, DZ, EC, EE,
EG, ES, FI, GB, GD, GE, GH, GM, GT, HN, HR, HU, ID,
IL, IN, IS, JP, KE, KG, KM, KN, KP, KR, KZ, LA, LC, LK,
LR, LS, LT, LU, LY, MA, MD, ME, MG, MK, MN, MW,
MX, MY, MZ, NA, NG, NI, NO, NZ, OM, PG, PH, PL, PT,
RO, RS, RU, SC, SD, SE, SG, SK, SL, SM, ST, SV, SY, TJ,
TM, TN, TR, TT, TZ, UA, UG, US, UZ, VC, VN, ZA, ZM,
ZW.

(84) Designated States (unless otherwise indicated, for every
kind of regional protection available): ARIPO (BW, GH,
GM, KE, LS, MW, MZ, NA, SD, SL, SZ, TZ, UG, ZM,
ZW), Eurasian (AM, AZ, BY, KG, KZ, MD, RU, TJ, TM),
European (AT, BE, BG, CH, CY, CZ, DE, DK, EE, ES, FI,

[Continued on next page]

(54) Title: CATHETER RECEPTACLE PROVIDED WITH AN ANTIMICROBIAL COMPOUND

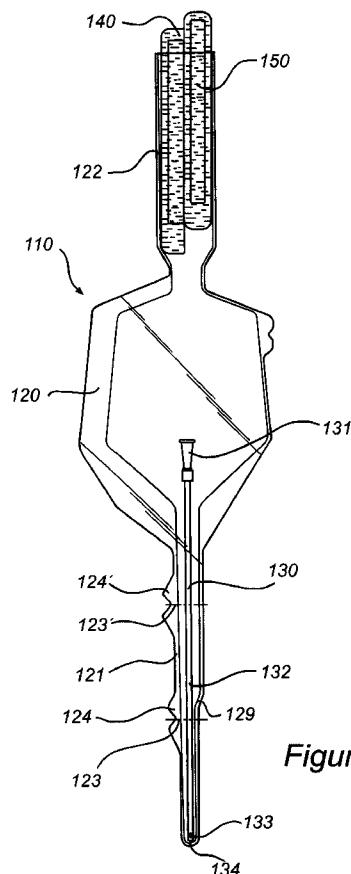

Figure 1

(57) Abstract: A catheter assembly (110, 210) comprising a catheter (130, 230) and a receptacle (120, 220) is disclosed. The receptacle is arranged to accommodate at least part of said catheter and having at least one opening (123) for withdrawal of said catheter. Further, the receptacle is provided with an antimicrobial compound (301) at least in the vicinity of the opening and at least on the outer surface of the receptacle, said antimicrobial compound inhibiting microbes from being transferred to said catheter while being withdrawn through said at least one opening.

WO 2009/043872 A1



FR, GB, GR, HR, HU, IE, IS, IT, LT, LU, LV, MC, MT, NL,
NO, PL, PT, RO, SE, SI, SK, TR), OAPI (BF, BJ, CF, CG,
CI, CM, GA, GN, GQ, GW, ML, MR, NE, SN, TD, TG).

Published:

— *with international search report*

Declaration under Rule 4.17:

— *as to applicant's entitlement to apply for and be granted a
patent (Rule 4.17(ii))*

CATHETER RECEPTACLE PROVIDED WITH AN ANTIMICROBIAL COMPOUND

Technical Field of the Invention

The present invention relates to a catheter assembly comprising a catheter and a receptacle, the receptacle accommodating at least part of the catheter and having at least one opening for withdrawal of the catheter. The present invention also relates to a method for manufacturing of such a catheter assembly.

Background Art

Catheters find their use in many different medical applications, such as urinary catheters for bladder drainage.

These urinary catheters are used in a variety of populations, including the elderly, stroke victims, spinal cord-injured patients, post-operative patients and those with obstructive uropathy. Despite adherence to sterile guidelines for the insertion and maintenance of urinary catheters, catheter-associated infections continues to pose a major problem. When medical devices such as a catheter is introduced into the human cavity, the normal human defense barrier may be penetrated, which can result in introduction of bacteria, fungi, vira, or tissue-like or multiple organized cells. Urinary tract infection (UTI), for instance, is a problem associated with the use of urinary catheters, including hydrophilic catheters with hydrophilic coatings for intermittent use. It is estimated that almost one-quarter of hospitalized spinal cord-injured patients develop symptomatic UTI during their hospital course. Gram-negative *bacilli* account for almost 60-70%, *enterococci* for about 25% and *Candida* species for about 10% of cases of UTI. It is well known that persons practicing intermittent urethral catheterization as a daily routine often have problems with symptomatic UTI.

In order to maintain the catheter in a clean and preferably sterile condition, each catheter is normally pre-packed in a receptacle by the manufacturer.

Additionally, in order to facilitate the use and to improve cleanliness of the catheter, the assemblies have in recent years developed to comprise a rupturable wetting fluid pouch or container as well, where wetting of the

catheter may be performed without the use of externally supplied water, and without breaking the sealed condition of it until intended use of the catheter. Such assemblies are disclosed in for instance WO 97/26937, WO 01/43807 and WO 98/11932. Further, so called "ready-to-use" catheters have been proposed, where the catheter is arranged in the receptacle together with a wetting fluid in such a way that the catheter is maintained in a wetted, activated condition by said fluid. Such ready-to-use catheter assemblies are disclosed in for instance WO 00/47494 and WO 98/19729.

Further, in order to maintain sterility and cleanness of the catheter, the catheter may be coated with an antimicrobial compound for prevention of bacterial infection. US 2006/0240069, for instance, discloses a use of at least one salt of organic acid(s), and preferably a benzoate or a sorbate, as an antimicrobial agent. The compound described can also be incorporated in a wetting fluid, usable for providing low-friction surface character of a hydrophilic coating of a catheter by treatment with the wetting fluid, for making the hydrophilic coating antimicrobial when activated by the wetting fluid. Further, WO 00/09173 discloses a stabilized composition having antibacterial, antiviral and/or antifungal activity characterized in that it comprises a silver compound. Light stabilized silver composition can be introduced into catheters or similar medical devices.

However, although antimicrobial coating as well as the maintenance of the catheter in a sterile condition serve to inhibit bacterial growth and prevent bacterial infections, insertion of the catheter into the urethra continues to constitute a risk for introduction of bacteria into the human body. One of the causes for this is that bacteria may still be transferred to the catheter during withdrawal of the catheter from its receptacle. Specifically, the withdrawal from the receptacle pose a problem when the outer surface of the receptacle is prone to come into contact with the catheter as the catheter is withdrawn, thus enabling bacteria from the receptacle to come into contact with the catheter.

Therefore, there is still a need for improved means for inhibiting bacterial infections and similar diseases related to growth and transfer of microbes in the use of catheters.

Summary of the Invention

It is therefore an object of the present invention to provide a catheter assembly of the type mentioned by way of introduction and a method for

manufacturing the same, in which the above related drawbacks are eliminated wholly or at least partly.

According to a first aspect of the invention, a catheter assembly comprising a catheter and a receptacle is provided, the receptacle accommodating at least part of the catheter and having at least one opening for withdrawal of the catheter. The receptacle is provided with an antimicrobial compound at least in the vicinity of the one opening and at least on the outer surface of the receptacle, the antimicrobial compound inhibiting microbes from being transferred to the catheter while it is being withdrawn through the at least one opening.

The invention likewise concerns a method of manufacturing a catheter assembly of the kind defined above. Thus, according to a second aspect of the invention, there is provided a method of manufacturing a catheter assembly comprising a catheter and a receptacle, comprising the steps of:

accommodating at least part of the catheter in the receptacle,
providing the receptacle with at least one opening for withdrawal of the catheter, and

providing the receptacle with an antimicrobial compound at least in the vicinity of the one opening and at least on the outer surface of the receptacle, the antimicrobial compound inhibiting microbes from being transferred to the catheter while it is being withdrawn through the at least one opening.

Incorporating an antimicrobial compound in a polymer is known in the art, and for instance US 6,716,200 discloses an antimicrobial urine collection system, in which the urine collection bag is made from a polymer comprising an antimicrobial agent. However, according to the teaching of this document, the antimicrobial compound is solely to be incorporated in a urine collection bag and the catheter itself, not the receptacle in which the catheter is accommodated, which is the case for the present invention. The purpose of adding the antimicrobial agent to the material also differs, as the described invention aims to prevent pathogens from migrating from a urine collection bag up through a catheter and into the urethra. The purpose of the present invention on the other hand, is to inhibit bacteria to be transferred from the receptacle to the catheter as the catheter is withdrawn through the receptacle opening or openings.

The term "opening" is in this application used to indicate any part of the receptacle which is intended to be brought from a closed disposition to an open disposition when the catheter is to be released and/or activated for use.

The transfer of microbes is avoided by adding to or incorporating in the receptacle, at least in the vicinity of the openings and at least on the outer surface of the receptacle, add an antimicrobial compound. The compound functions to inhibit growth of bacteria on the receptacle, for instance colonization on the surface. Consequently, the risk of contaminating the catheter as it comes into contact with the outer surface of the receptacle during withdrawal through the receptacle opening or openings is reduced, and consequently the risk of bacterial infections and similar diseases is alleviated.

A catheter in accordance with the present invention is particularly useful for urinary catheters, and especially for single-use urinary catheters intended for intermittent use. Consequently, the risk of being infected by UTI decreases for, for instance, patients practicing intermittent urethral catheterization as a daily routine.

Furthermore the catheter preferably has, on at least part of its surface, a hydrophilic surface layer providing low-friction surface character of the device by treatment with a wetting fluid.

It is known in the art that by applying a hydrophilic coating to the catheter, a low-friction effect is activated as wetting fluid comes into contact with the hydrophilic surface. Consequently, the coating facilitates insertion of the catheter into a human cavity, for instance the urethra.

Preferably, the catheter assembly further comprises a wetting fluid.

By allowing a wetting fluid forming part of the catheter assembly, no additional wetting fluid is needed for activation of the catheter, which entails many advantages. For example, activation of the catheter could easily be accomplished in places where it is normally difficult to find an appropriate wetting fluid for this specific use. Further, it could be ensured that only a sufficiently clean and sterile fluid is used, thereby decreasing the risk for unwanted contamination of the catheter. Still further, the wetting of the catheter may be accomplished in a simpler and more convenient manner.

A suitable wetting fluid could typically be sterile water or saline.

The amount of wetting fluid provided is preferably sufficient for filling the receptacle to a certain degree and to ensure that an adequate wetting of the catheter is maintained.

The wetting fluid may furthermore be arranged in wetting contact with the hydrophilic surface layer of the catheter in the receptacle, for preservation of the hydrophilic surface layer in a wetted state during accommodation in the receptacle and provision of a ready-to-use catheter assembly.

The catheter assembly may also present a storage state in which the wetting fluid is kept separated from the hydrophilic surface layer of the catheter, and an activation state in which the wetting fluid is brought into contact with the hydrophilic surface layer before an intended use of the catheter.

The catheter is thus according to the former embodiment activated already during production, and is then maintained in an activated ready-to-use condition, whereas the wetting fluid of the catheter assembly according to the latter embodiment, initially is kept separated from the hydrophilic surface layer of the catheter during storage of the assembly, and is brought into contact with the hydrophilic surface layer upon activation prior to use.

After the receptacle is opened, the receptacle could either be ripped off and then disposed of, or, according to one embodiment, be maintained connected to the catheter and used as a urine collection bag. Utilizing the receptacle as a container for receiving the drained urine from the bladder may contribute to less spillage, as the catheter maintains connected to the receptacle during, as well as after, the drainage.

At least part of the receptacle may form an elongate pocket of length sufficient to accommodate at least the insertable length of the catheter.

Additionally, at least one opening is preferably arranged on the elongate pocket.

Even more preferred is for the receptacle to have at least two openings positioned such that an intermediate part of the elongate pocket may be used as an insertion aid for guiding and holding the wetted catheter during insertion into the human cavity, for instance the urethra.

To facilitate the removal of the catheter from the receptacle and the insertion into, for instance, the urethra of a patient, at least one area of weakness is preferably arranged on the receptacle in the area of the elongate pocket, in which the catheter is placed. The area of weakness provides, through for instance tearing or twisting, an opening in the receptacle, and positioning of this opening on the elongate pocket serves to facilitate unpacking of the catheter before intended use.

Most preferably, two such areas of weakness are provided and separated in the lengthwise direction of the receptacle. The intermediate part of the elongate pocket may be used as an insertion aid for guiding and holding the wetted catheter when it is inserted into, for instance, the urethra. There is therefore no need to directly handle the catheter for insertion thereof

into the human cavity, which is an advantage as the outer surface of the catheter will be slippery due to the wetting procedure and therefore difficult to grip and furthermore because the possibility of contamination of the catheter at this stage is avoided, whereby the cleanness and sterility of the catheter may be maintained.

The at least one opening is preferably a tear opening.

The term "tear opening" is, in the context of this application, to be understood in a broad sense, meaning an opening which is torn open by pulling parts of the receptacle material in essentially opposite directions. This type of openings are well known in the art, and are often advantageous for many different reasons. However, these openings provide a risk of contamination of the catheter, since the contact may come into contact with the non-sterile outer surface of the receptacle during withdrawal. However, the present invention is also applicable and useful for receptacles having other types of openings, such as peel-openings.

The receptacle preferably comprises opening means for facilitating opening of the receptacle in order to expose the catheter prior to use. The opening means could comprise one or several areas of weakness as discussed in the foregoing, and preferably tear lines connected to one or several gripping handles, for instance pulling tabs. Pulling tabs may be arranged on one or both sides of the area of weakness, in order to facilitate tearing open the receptacle.

Preferably the receptacle is formed of a flexible plastics material, for which the advantage of a bendable receptacle arises, contributing to the catheter assembly being easy to stow.

Arranging the antimicrobial compound as a coating on the outer surface of the receptacle material, or even incorporate therein, are preferred manners in which the antimicrobial compound is added to the receptacle for prevention of bacterial growth. The presence of the compound is, in order to inhibit transfer of microbes from the receptacle to the catheter as the catheter is being withdrawn from the receptacle through one or several openings, most critical in the vicinity of the openings.

The amount of the antimicrobial compound in the receptacle material may be in the range 0.1 to 20 phr (parts per hundred resin), and preferably in the range 0.5 to 7.5 phr, and most preferably about 4.5 phr.

The antimicrobial compound is preferably an organic acid metal salt, and may further comprise phosphoric acid esters and zinc metal.

Furthermore, the antimicrobial compound may comprise one or several of silver nitrate, silver acetate or silver lactate.

The above stated antimicrobial compounds and their concentrations in the receptacle material have proven to provide suitable antimicrobial effectiveness. Thus, by usage of a catheter assembly in accordance with the present invention comprising either of these compounds, within the given ranges, the transfer of microbes from the receptacle to the catheter as the catheter is being withdrawn from the receptacle, is avoided.

Other aspects, benefits and advantageous features of the invention will be apparent from the following description and claims.

Brief Description of the Drawings

For exemplary purpose, the invention will in the following be described in more detail by means of the specific embodiments, and with reference to the accompanying drawings, which illustrate:

Figure 1 shows a catheter according to a first embodiment of the present invention, with the receptacle forming a urine collection bag.

Figure 2 shows a catheter assembly according to a second embodiment.

Figure 3a shows a cross-section of the receptacle, wherein the antimicrobial compound constituting a layer on the outer surface of the receptacle material.

Figure 3b shows a cross-section of the receptacle, wherein the antimicrobial compound incorporated in the receptacle material.

Detailed Description of Preferred Embodiments of the Invention

In the following detailed description, preferred embodiments of the present invention will be described. However, it is to be understood that features of the different embodiments are exchangeable between the embodiments and may be combined in different ways, unless anything else is specifically indicated. It may also be noted that, for the sake of clarity, the dimensions of certain components illustrated in the drawings may differ from the corresponding dimensions in real-life implementations of the invention, for instance the length of the catheter, the dimensions of the fluid compartments etc.

A catheter 130 as illustrated in Figure 1, comprises a flared rearward portion 131 and an elongate shaft or tube 132 projecting forwardly from the rearward portion 131. An open-ended internal lumen (not shown) extends

from the rear end of the rearward portion 131 to a drainage aperture 133 in a rounded tip 134 of the elongate tube 132. The rearward portion 131 may function as a connector of the catheter 130, being connectable to other devices, such as a urine collection bag, a drainage tube or the like.

At least a part of the elongate tube 132 forms an insertable length to be inserted through a body opening of the user, such as the urethra in case of a urinary catheter. By "insertable length" is normally, in the context of a hydrophilic catheter, meant the length of the elongate tube 132 which is coated with a hydrophilic material, for example PVP, and which is insertable into the urethra of the patient. Typically, this will be 80-140 mm for a female patient and 200-350 mm for a male patient.

According to the invention, and applicable for the embodiments disclosed herein, many different types of well-known hydrophilic materials can be used. For example, the catheter may be provided with a hydrophilic coating wherein the hydrophilic polymer coating comprises material selected from polyvinyl compounds, polysaccharides, polyurethanes, polyacrylates or copolymers of vinyl compounds and acrylates or anhydrides, especially polyethyleneoxide, polyvinyl-pyrrolidone, heparin, dextran, xanthan gum, polyvinyl alcohol, hydroxy propyl cellulose, methyl cellulose, copolymer of vinylpyrrolidone and hydroxy ethylmethyl acrylate or copolymer of polymethylvinyl ether and maleinic acid anyhydride. The preferred hydrophilic polymer is polyvinylpyrrolidone.

Upon use, the catheter 130 is wetted by a wetting fluid 150. The wetting fluid 150 serves the primary purpose of wetting the hydrophilic surface coating, whereby a low-friction character of the surface is produced and the catheter 130 becomes slippery and easy to insert into, for instance, the urethra of the patient. The wetting fluid 150 is preferably a water-based liquid, that is, using water as a solvent. Further, it is also possible to provide a dissolved antimicrobial compound in the fluid. Still further, the wetting fluid 150 could also comprise a dissolved hydrophilic polymer, and preferably the same type of hydrophilic polymer as in the hydrophilic coating of the catheter for which the wetting fluid 150 is intended. In this case, the amount of hydrophilic polymer in the wetting fluid is preferably in the range 0-20% of weight, and most preferably in the range 5-15%, and typically about 10%.

With reference to Figure 1, a first embodiment of a catheter assembly 110 will now be described, the structure of which generally resembles

embodiments previously disclosed in US 6 409 717, said document hereby incorporated by reference.

The catheter assembly 110 comprises a wetting receptacle or bag 120, preferably of a transparent flexible plastics material. The receptacle 120 has an elongate pocket 121 at its forward end. At its rearward end 122 the receptacle presents an opening. The wetting receptacle 120 is adapted for accommodation of at least the insertable length of the catheter tube 132 in the elongate pocket 121.

The catheter assembly 110 further comprises a hydrophilic urinary catheter 130, of the type discussed in more detail in the foregoing.

The catheter 130 may be arranged in a package without any wetting fluid, wherein a wetting fluid is provided externally. However, preferably the catheter 130 is arranged in an assembly additionally comprising a wetting fluid 150, such as in the embodiment of fig 1. In this embodiment, the catheter assembly 110 comprises a wetting fluid 150 arranged in a separate compartment of the receptacle, and forming part of the assembly 110. More specifically, in the embodiment in Figure 1, the catheter assembly 110 further comprises a wetting fluid container 140, in which the wetting fluid 150 is kept separated from the hydrophilic surface of the catheter 130 during storage.

The wetting fluid container 140 is openable, in order to enable activation of the catheter assembly 110. Thus, the activation is performed by opening the container 140 and releasing the wetting fluid 150 into the wetting receptacle 120 so that it comes into contact with the hydrophilic coating of the catheter. The wetting fluid container 140 may be openable by means of pressing, tearing, piercing, twisting, etc, which is per se well known in the art.

The wetting receptacle 120 preferably forms a sealed compartment around the catheter 130 and at least part of the wetting fluid container 140.

Furthermore, the wetting receptacle 120 preferably comprises opening means for facilitating opening of the receptacle in order to expose the catheter 130 for use. The opening means may comprise a tear line 123 connected to a gripping handle 124, such as a pulling tab, forming a tear opening. Hereby, the user may pull the gripping handle 124 and, thereby, tearing open the side wall of the wetting receptacle 120. Additionally, or alternatively, a gripping handle may be arranged in the opposite end of the tear line 123. However, alternative opening means are also feasible, such as tear-lines arranged in different fashions and locations, peel-off joints, etc.

Most preferably, at least two openings 123, 123' are positioned such that an intermediate part of the elongate pocket 121 may be used as an insertion aid for guiding and holding the wetted catheter 130 during insertion into the human cavity, for instance the urethra. In the exemplifying embodiment in Figure 1, an additional tear line 123' is provided on the elongate pocket, along with a gripping handle 124'. The areas of weakness 123, 123' should if the receptacle 120 also serves as a urinary collection bag, which is the case in Figure 1, preferably be placed beneath the restriction 129.

In a method of wetting the catheter 130 according to the embodiment in Figure 1, the user first activates the catheter 130 by opening the wetting fluid container 140 within the bounds of the wetting receptacle 120, thereby releasing the wetting fluid 150 from the container 140 into the wetting receptacle 120. After a sufficient wetting period, the wetting receptacle 120 is opened, in order to expose the catheter 130 for insertion into a patient.

In the embodiment in Figure 1, the wetting receptacle 120 also serves as a urine collection bag. In this case, after wetting of the catheter 130 for the predetermined duration in the same manner as described above, the bag 120 is turned upside down and the forwardmost portion of the elongate pocket 121 is torn off. The elongate shaft 132 of the catheter is then maneuvered through the opening in the forward end of the elongate pocket 121 and pulled out until the flared rearward portion 131 forms a mechanical seal connection with the opening at a restriction 129 of the receptacle. Thereafter, the catheter 130 is inserted into the urethra of the patient. Thus, being opened, the receptacle 120 maintains connected to the catheter 130 for receiving the drained urine from the bladder. However, this is merely optional, and a package not serving as a urine collection bag is equally feasible. Such an embodiment is illustrated in Figure 2, which resembles the structure of some embodiments discussed in US 2005/043715, said document hereby incorporated by reference.

Alternatively, the catheter assembly 110 may comprise a package only partly enclosing the catheter 130, as is also disclosed in US 2005/043715, said document hereby incorporated by reference. It is also possible to arrange the wetting fluid container 140 not in a separate compartment of the receptacle 120, but integrated with the compartment holding the catheter 130. Hereby, the catheter 130 is activated already during production, and is then maintained in an activated, ready-to-use condition. Thus, in this embodiment,

the hydrophilic surface layer is preserved in a wetted state during accommodation in the receptacle 120 and a ready-to-use catheter 130 is provided. In order to preserve this wetted condition, the compartment formed by the receptacle 120 and the catheter 130 is preferably gas sealed, and further, the receptacle 120 is preferably gas impermeable. In use, the receptacle 120 is simply opened, and the catheter 130 could immediately be introduced into the patient. Such an assembly 110 is for instance disclosed in US 6 848 574, said document hereby incorporated by reference.

Figure 2 shows a catheter assembly 210 which comprises a wetting receptacle or bag 220 and a catheter 230 comprising a flared rearward portion and an elongate shaft or tube projecting forwardly from the rearward portion 231. The receptacle 220 has an elongate pocket 221 at its forward end. Upon use, the catheter 230 is wetted by a wetting fluid 250.

In the embodiment of Figure 2, the catheter is removed from the receptacle before or during insertion into the urethra, since the receptacle 220, as discussed in the foregoing, after opening should be disposed, that is, the receptacle 220 is in contrast to the catheter assembly 110 in Figure 1 not serving as a urine collection bag. Other features, however, resemble features described in the foregoing in association to the embodiment in Figure 1, why further description is omitted.

Figure 3a and 3b illustrate the antimicrobial compound 301 constituting a layer 302 on the outer surface of the receptacle material 303, and the antimicrobial compound 301 incorporated in the receptacle material 303, respectively.

Utilizing these exemplifying, preferred manners for providing the receptacle material 303 with the antimicrobial compound 301, enable the receptacle material 303 to inhibit bacterial growth. By adding the compound 301 particularly in the vicinity of the receptacle openings 123, 123', bacterial transfer from the receptacle 110, 210 to the catheter 120, 220, as the catheter 120, 220 is withdrawn from the receptacle 110, 210, is avoided.

The antimicrobial compound 301 in the receptacle material 303 could be in the range 0.1 to 20 phr (parts per hundred resin), and preferably in the range 0.5 to 7.5 phr, and most preferably about 4.5 phr.

Furthermore, the antimicrobial compound 301 is preferably an organic acid metal salt and comprises, according to one embodiment, phosphoric acid esters and zinc metal. According to another embodiment, the antimicrobial compound 301 is one of silver nitrate, silver acetate or silver lactate.

The invention has now been discussed in relation to different embodiments. However, it should be appreciated by those skilled in the art that several further alternatives are possible. For example, the features of the different embodiments discussed above may naturally be combined in many other ways.

It is further possible to use the invention for other types of catheters than urinary catheters, such as vascular catheters or the like.

Still further, it is possible to arrange the wetting fluid container in many different ways. For example, the container may be a separate container, but forming part of the assembly. Such a wetting fluid container may be arranged completely inside the receptacle, partly inside the receptacle, or completely outside the receptacle. Alternatively, the wetting fluid container may be an integrated compartment of the receptacle. This compartment may be separated from the compartment housing the insertable part of the catheter, or be integrated with such a compartment. In the latter case, the catheter may be maintained in a wetted, activated state.

Further, the wetting fluid container may be arranged close to the distal part of the catheter, close to the proximal part of the catheter, or in any other suitable location in the assembly. In case the wetting fluid is arranged separately from the insertable part of the catheter, the separation wall or joint could e.g. be a breakable or peelable membrane wall, but alternative embodiments are naturally feasible, such as various types of detachable or openable caps or closings. The wetting fluid container may be arranged to be discharged upon application of a twist, a compression, a pull or the like on the fluid container. Preferably the wetting fluid may be discharged without breaking or rupturing the receptacle, even though this may not be necessary, depending on the intended use, etc.

Many different materials could also be used for the different parts of the catheter assembly.

It will be appreciated by those skilled in the art that several such alternatives similar to those described above could be used without departing from the spirit of the invention, and all such modifications should be regarded as a part of the present invention, as defined in the appended claims.

Claims

1. Catheter assembly (110, 210) comprising a catheter (130, 230) and a receptacle (120, 220) said receptacle accommodating at least part of said catheter and having at least one opening (123) for withdrawal of said catheter, wherein said receptacle is provided with an antimicrobial compound (301) at least in the vicinity of said one opening and at least on the outer surface of the receptacle, said antimicrobial compound inhibiting microbes from being transferred to said catheter while being withdrawn through said at least one opening.
2. Catheter assembly according to claim 1, wherein said catheter is a urinary catheter, and preferably intended for intermittent use.
3. Catheter assembly according to claim 2, further comprising a wetting fluid (150, 250).
4. Catheter assembly according to any one of the preceding claims, wherein said catheter has on at least part of its surface a hydrophilic surface layer providing low-friction surface character of the device by treatment with a wetting fluid.
5. Catheter assembly according to claim 4, wherein said wetting fluid is arranged in wetting contact with said hydrophilic surface layer of said catheter in said receptacle, for preservation of said hydrophilic surface layer in a wetted state during accommodation in said receptacle and provision of a ready-to-use catheter assembly.
6. Catheter assembly according to claim 4, wherein said catheter assembly presents a storage state in which said wetting fluid is kept separated from said hydrophilic surface layer of said catheter, and an activation state in which said wetting fluid is brought into contact with said hydrophilic surface layer before an intended use of said catheter.
7. Catheter assembly according to any one of the preceding claims, wherein said receptacle forms a urine collection bag.

8. Catheter assembly according to any one of the preceding claims, wherein at least a part of said receptacle forms an elongate pocket (121, 221) of length sufficient to accommodate at least the insertable length of said catheter.

9. Catheter assembly according to claim 8, wherein said at least one opening is arranged on said elongate pocket.

10. Catheter assembly according to claim 9, wherein said receptacle has at least two openings (123,123') positioned such that an intermediate part of said elongate pocket may be used as an insertion aid for guiding and holding the wetted catheter during insertion into the human cavity, for instance the urethra.

11. Catheter assembly according to any one of the preceding claims, wherein said at least one opening is a tear opening.

12. Catheter assembly according to any one of the preceding claims, wherein said receptacle is formed of a flexible plastics material.

13. Catheter assembly according to any one of the preceding claims, wherein said antimicrobial compound constitutes a layer (302) on the outer surface of said receptacle material 303.

14. Catheter assembly according to any one of the preceding claims, wherein said antimicrobial compound is incorporated in said receptacle material.

15. Catheter assembly according to any one of the preceding claims, wherein the amount of said antimicrobial compound in said receptacle material is in the range 0.1 to 20 phr (parts per hundred resin), and preferably in the range 0.5 to 7.5 phr, and most preferably about 4.5 phr.

16. Catheter assembly according to any one of the preceding claims, wherein said antimicrobial compound is an organic acid metal salt.

17. Catheter assembly according to claim 16, wherein said organic acid metal salt comprises phosphoric acid esters and zinc metal.

18. Catheter assembly according to any one of the preceding claims, wherein said antimicrobial compound is one of silver nitrate, silver acetate or silver lactate.

19. Method of manufacturing a catheter assembly comprising a catheter and a receptacle, comprising the steps of:
accommodating at least part of said catheter in said receptacle,
providing said receptacle with at least one opening for withdrawal of said catheter, and
providing said receptacle with an antimicrobial compound at least in the vicinity of said one opening and at least on the outer surface of the receptacle, said antimicrobial compound inhibiting microbes from being transferred to said catheter during withdrawal through said at least one opening.

20. Method according to claim 19, further comprising the step of:
providing said catheter, on at least part of its surface, with a hydrophilic surface layer providing low-friction surface character of the device by treatment with a wetting fluid.

21. Method according to claim 20, further comprising the step of:
arranging said wetting fluid in wetting contact with said hydrophilic surface layer of said catheter in said receptacle, for preservation of said hydrophilic surface layer in a wetted state during accommodation in said receptacle and provision of a ready-to-use catheter assembly.

22. Method according to claim 20, further comprising the step of:
arranging said catheter assembly such that it presents a storage state in which said wetting fluid is kept separated from said hydrophilic surface layer of said catheter, and an activation state in which said wetting fluid is brought into contact with said hydrophilic surface layer before an intended use of said catheter.

23. Method according to any one of claims 19 to 22, wherein the step of accommodating at least part of said catheter in said receptacle, at least a part of said receptacle forms an elongate pocket of length sufficient to accommodate at least the insertable length of said catheter.

24. Method according to claim 23, wherein the step of providing said receptacle with at least one opening for withdrawal of said catheter, said at least one opening is arranged on said elongate pocket.

25. Method according to claim 24, wherein at least two openings are positioned such that an intermediate part of said elongate pocket may be used as an insertion aid for guiding and holding the wetted catheter during insertion into the urethra.

1/3

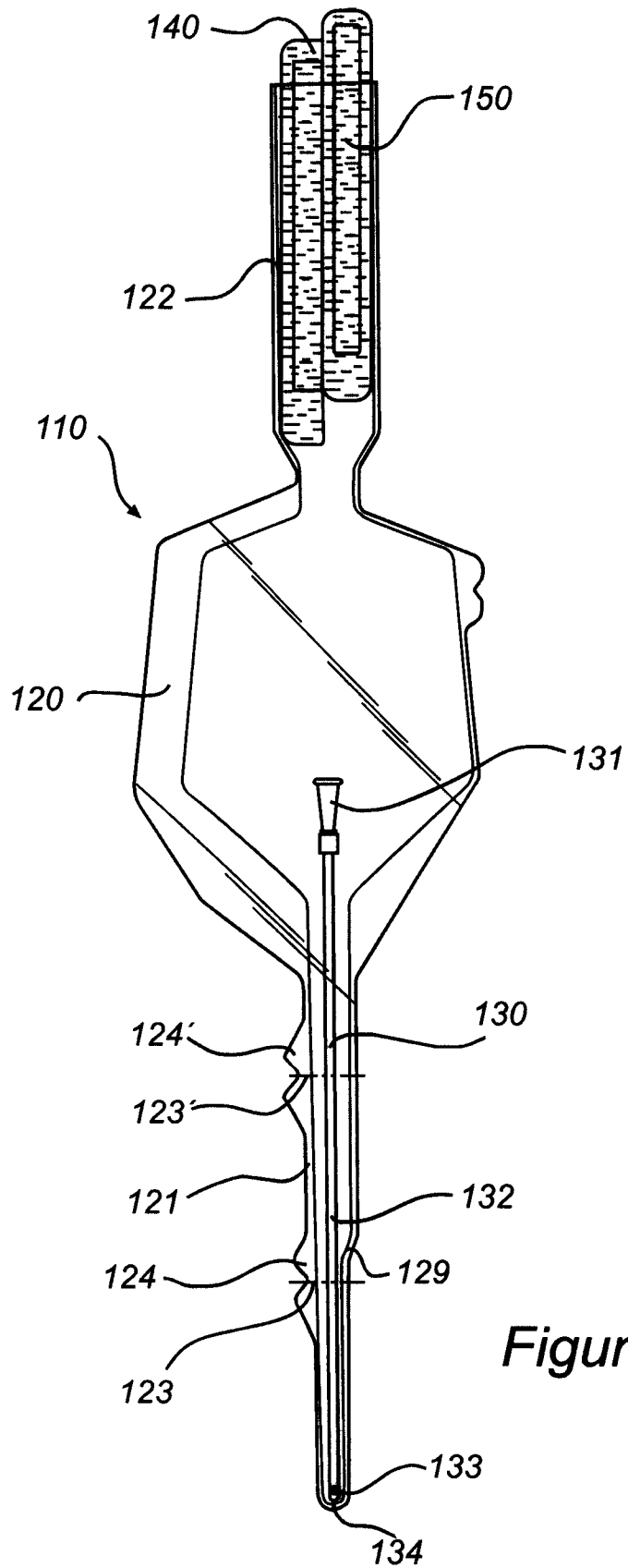

Figure 1

2/3

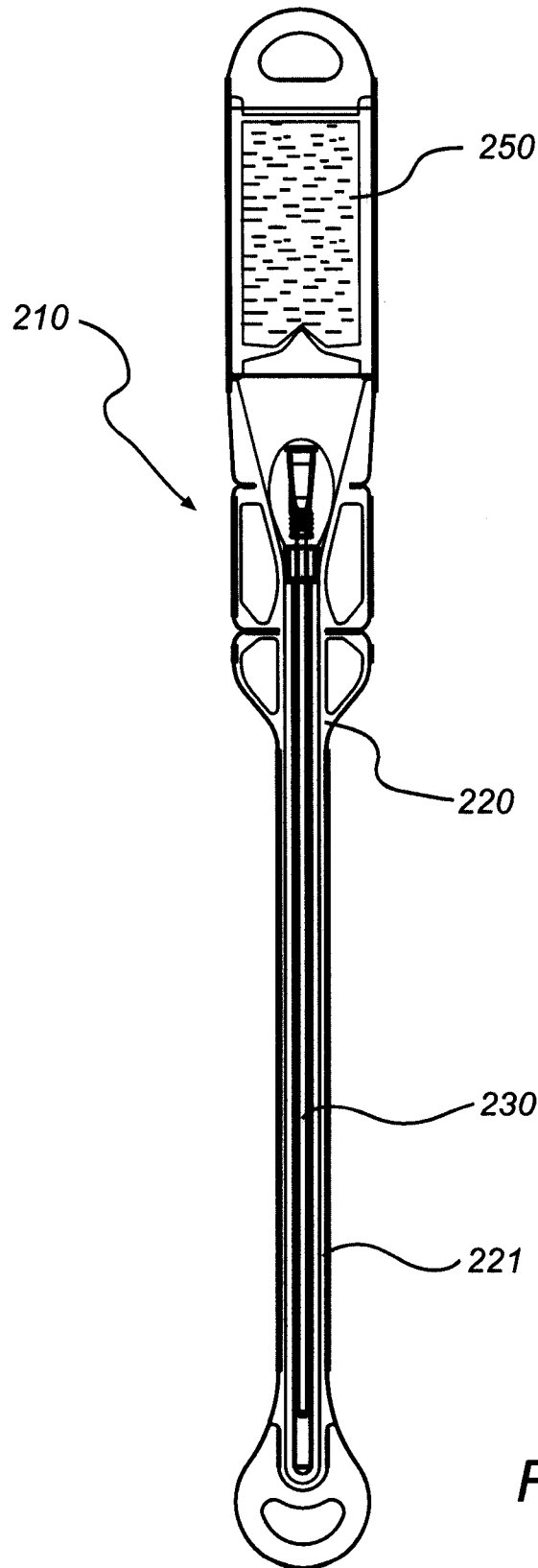

Figure 2

3/3

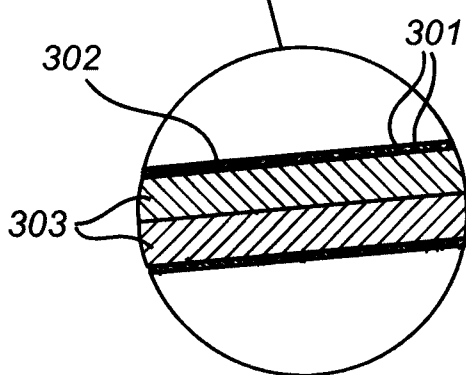
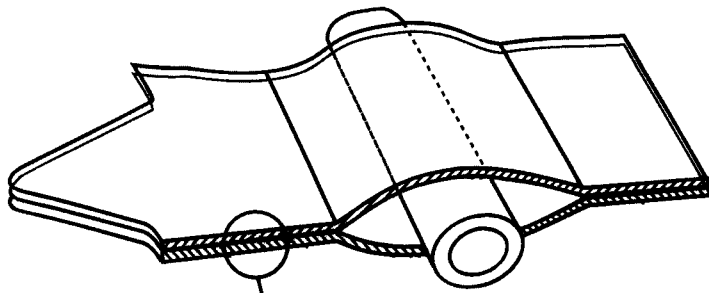

Figure 3a

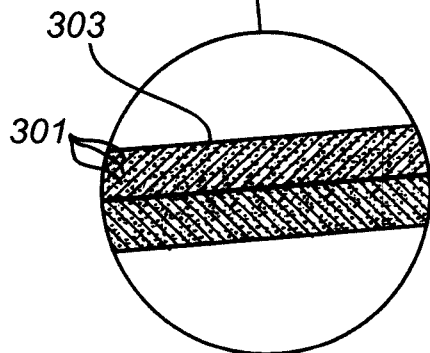
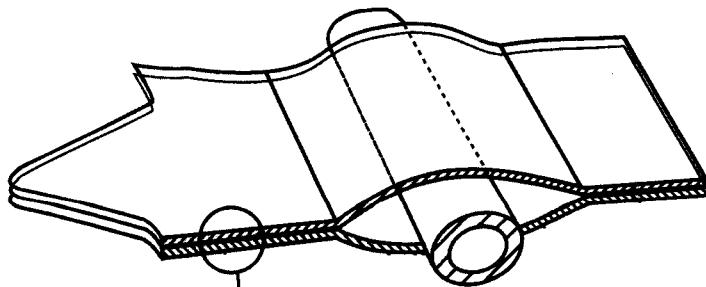

Figure 3b

INTERNATIONAL SEARCH REPORT

International application No
PCT/EP2008/063143

A. CLASSIFICATION OF SUBJECT MATTER
INV. A61L29/14 A61L29/16 A61M25/00

According to International Patent Classification (IPC) or to both national classification and IPC

B. FIELDS SEARCHED

Minimum documentation searched (classification system followed by classification symbols)
A61M A61L

Documentation searched other than minimum documentation to the extent that such documents are included in the fields searched

Electronic data base consulted during the international search (name of data base and, where practical, search terms used)

EPO-Internal, WPI Data

C. DOCUMENTS CONSIDERED TO BE RELEVANT

Category*	Citation of document, with indication, where appropriate, of the relevant passages	Relevant to claim No.
X	US 2006/240069 A1 (UTAS JAN [SE] ET AL) 26 October 2006 (2006-10-26) cited in the application	1-9, 12, 14-23
Y	page 1, paragraph 9 - page 2, paragraph 19 page 2, paragraph 23 - paragraph 24 page 2, paragraph 27 - page 3, paragraph 33 page 3, paragraph 36 - paragraph 41 claims 1-36 figures 1,2	1-25
	----- -/--	

Further documents are listed in the continuation of Box C.

See patent family annex.

* Special categories of cited documents :

- *A* document defining the general state of the art which is not considered to be of particular relevance
- *E* earlier document but published on or after the international filing date
- *L* document which may throw doubts on priority claim(s) or which is cited to establish the publication date of another citation or other special reason (as specified)
- *O* document referring to an oral disclosure, use, exhibition or other means
- *P* document published prior to the international filing date but later than the priority date claimed

- *T* later document published after the international filing date or priority date and not in conflict with the application but cited to understand the principle or theory underlying the invention
- *X* document of particular relevance; the claimed invention cannot be considered novel or cannot be considered to involve an inventive step when the document is taken alone
- *Y* document of particular relevance; the claimed invention cannot be considered to involve an inventive step when the document is combined with one or more other such documents, such combination being obvious to a person skilled in the art.
- *&* document member of the same patent family

Date of the actual completion of the international search

20 November 2008

Date of mailing of the international search report

28/11/2008

Name and mailing address of the ISA/

European Patent Office, P.B. 5818 Patentlaan 2
NL - 2280 HV Rijswijk
Tel. (+31-70) 340-2040.
Fax: (+31-70) 340-3016

Authorized officer

Menidjel, Razik

INTERNATIONAL SEARCH REPORT

International application No

PCT/EP2008/063143

C(Continuation). DOCUMENTS CONSIDERED TO BE RELEVANT

Category*	Citation of document, with indication, where appropriate, of the relevant passages	Relevant to claim No.
Y	US 2003/139730 A1 (BRACKEN RONALD L [US] ET AL) 24 July 2003 (2003-07-24) cited in the application page 1, paragraph 10 - page 2, paragraph 13 page 2, paragraph 21 - page 3, paragraph 24 page 3, paragraph 29 - paragraph 30 claims 1-24	1-25
X	US 5 779 687 A (BELL CRAIG J [US] ET AL) 14 July 1998 (1998-07-14) column 2, line 8 - line 40 column 2, line 58 - line 63 column 3, line 66 - column 4, line 15 claims 1-8	1-9,12, 14-23
Y	WO 00/09173 A (COLOPLAST AS [DK]; PEDERSEN LARS HAASTRUP [DK]; SAMUELSEN PETER BOMAN) 24 February 2000 (2000-02-24) cited in the application page 1, line 4 - line 8 page 3, line 18 - line 28 page 4, line 2 - line 11 page 8, line 15 - page 9, line 6 claims 1-10	1-25
Y	WO 01/43807 A (ASTRA TECH AB [SE]; NESTENBORG DANIEL [SE]; UTAS JAN [SE]; PETTERSSON) 21 June 2001 (2001-06-21) cited in the application page 3, line 5 - line 17 page 4, line 2 - line 5 page 4, line 23 - line 31 page 5, line 18 - line 29 page 6, line 14 - line 20 page 8, line 16 - line 28	1-25
A	WO 97/26937 A (ASTRA AB [SE]; ISRAELSSON ANETTE [SE]; PETTERSSON AGNETA [SE]; UTAS JA) 31 July 1997 (1997-07-31) cited in the application page 3, line 16 - page 4, line 28 page 5, line 5 - line 23 page 6, line 16 - line 26 claims 1-36 figures 1-4	1-25

INTERNATIONAL SEARCH REPORT

Information on patent family members

International application No

PCT/EP2008/063143

Patent document cited in search report	Publication date	Patent family member(s)	Publication date	
US 2006240069	A1	26-10-2006	AU 2006237662 A1	26-10-2006
			CA 2601031 A1	26-10-2006
			CN 101160145 A	09-04-2008
			EP 1714665 A2	25-10-2006
			WO 2006112782 A1	26-10-2006
US 2003139730	A1	24-07-2003	CA 2473542 A1	31-07-2003
			EP 1471959 A2	03-11-2004
			JP 2005526543 T	08-09-2005
			MX PA04006967 A	26-11-2004
			WO 03061732 A2	31-07-2003
US 5779687	A	14-07-1998	NONE	
WO 0009173	A	24-02-2000	AT 266429 T	15-05-2004
			AU 5153399 A	06-03-2000
			DE 69917285 D1	17-06-2004
			DE 69917285 T2	19-05-2005
			EP 1104311 A1	06-06-2001
			US 6468521 B1	22-10-2002
WO 0143807	A	21-06-2001	AT 353022 T	15-02-2007
			AU 782167 B2	07-07-2005
			AU 2418701 A	25-06-2001
			BR 0016453 A	10-09-2002
			CA 2394282 A1	21-06-2001
			CN 1409647 A	09-04-2003
			DE 60033237 T2	19-07-2007
			DK 1237615 T3	04-06-2007
			EP 1237615 A1	11-09-2002
			ES 2276712 T3	01-07-2007
			JP 2003516826 T	20-05-2003
			WO 9726937	A
AU 706432 B2	17-06-1999			
AU 1562697 A	20-08-1997			
BR 9707194 A	25-05-1999			
CA 2241989 A1	31-07-1997			
CN 1213976 A	14-04-1999			
CZ 9802328 A3	16-12-1998			
DE 69717860 D1	23-01-2003			
DE 69717860 T2	28-08-2003			
DK 959930 T3	31-03-2003			
EP 0959930 A1	01-12-1999			
ES 2188889 T3	01-07-2003			
HU 9901019 A2	30-08-1999			
IL 125427 A	01-12-2002			
IS 4796 A	13-07-1998			
JP 3320425 B2	03-09-2002			
JP 11504249 T	20-04-1999			
NO 983406 A	24-09-1998			
NZ 326930 A	23-12-1998			
PL 327859 A1	04-01-1999			
PT 959930 T	30-04-2003			
RU 2177338 C2	27-12-2001			
TR 9801397 T2	21-10-1998			
US 6409717 B1	25-06-2002			
ZA 9700535 A	30-07-1997			