

D. B. CAUDY & E. K. CUTLIP.
RAILWAY SWITCH.
APPLICATION FILED JUNE 15, 1910.

1,001,618.

Patented Aug. 29, 1911.

2 SHEETS—SHEET 2.

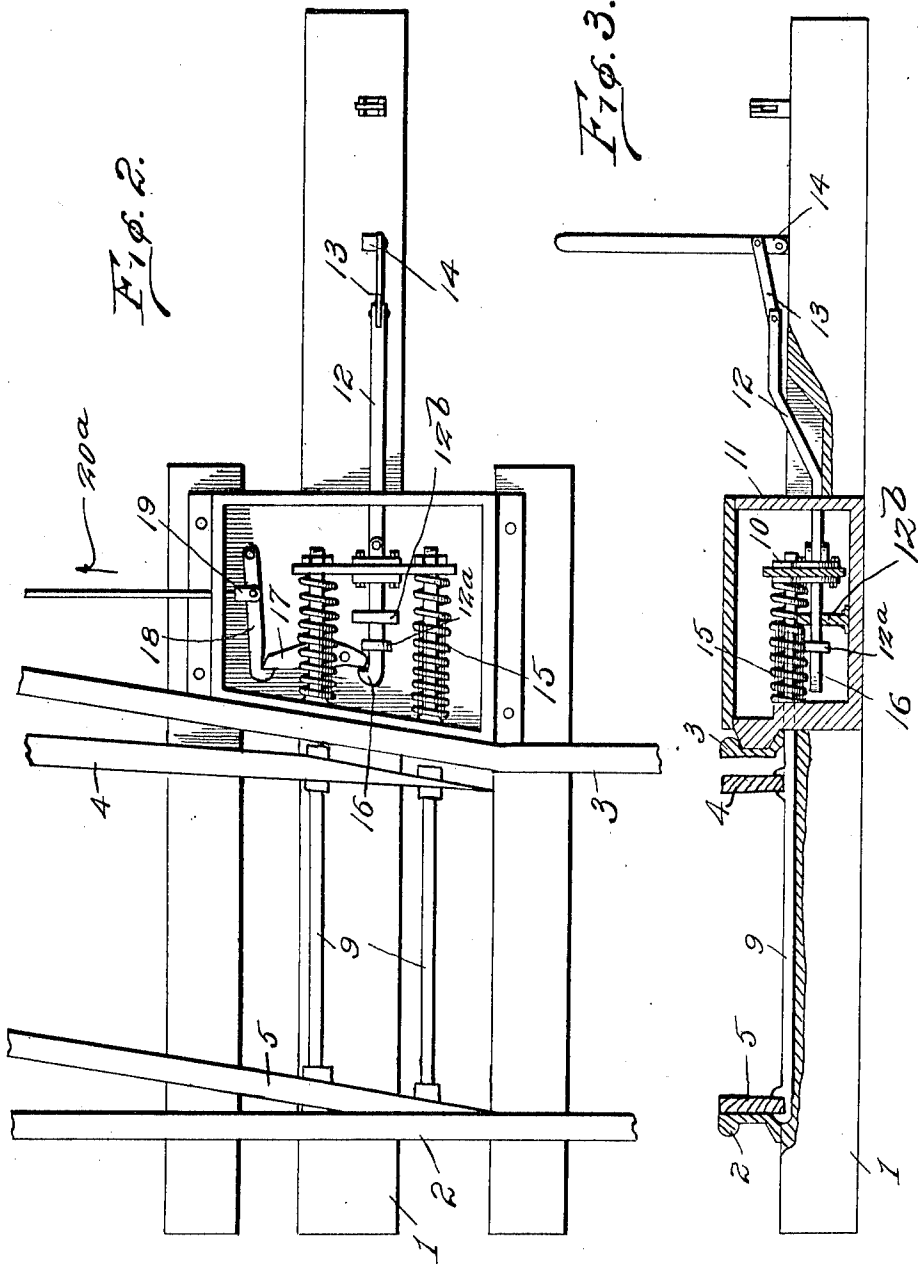

Witnesses

W. Moore

E. G. Duffy

Inventors
D. B. Caudy
E. K. Cutlip
By *D. Swift & Co.*

Attorneys

UNITED STATES PATENT OFFICE.

DANIEL B. CAUDY AND EDWARD K. CUTLIP, OF HOLCOMB, WEST VIRGINIA.

RAILWAY-SWITCH.

1,001,618.

Specification of Letters Patent. **Patented Aug. 29, 1911.**

Application filed June 15, 1910. Serial No. 567,663.

To all whom it may concern:

Be it known that we, DANIEL B. CAUDY and EDWARD K. CUTLIP, citizens of the United States, residing at Holcomb, in the county of Nicholas and State of West Virginia, have invented a new and useful Railway-Switch; and we do hereby declare the following to be a full, clear, and exact description of the invention, such as will enable others skilled in the art to which it appertains to make and use the same.

This invention relates to improvements in switches and its leading object is the construction of a switch operating mechanism whereby a main line will be held normally open.

Another object of the invention is the provision of an operating mechanism actuated by the car wheels, for releasing a member of the switch mechanism whereby the switch points may be restored from their abnormal positions to their normal positions.

With the above and other objects in view the invention relates to improved constructions, combinations and arrangements of parts, clearly described in the following specification and clearly illustrated in the accompanying drawings, in which,

Figure 1 is a plan view showing the main line open, Fig. 2 is a detail plan view showing the principal mechanism exposed to view, Fig. 3 is a detail vertical sectional view thereof, and Fig. 4 is a detail sectional view on line 4-4 of Fig. 1, looking in the direction of the arrow showing the weight operated device for actuating the switch holding mechanism.

Referring to the accompanying drawings illustrating the invention 1 denotes the ties, 2 the unbroken main line rail, 3 the siding rail which is turned to form connection with the other main line rail, 4 a movable main line rail section, which abuts against the rail 3, and 5 a movable switch rail section, which abuts against the main line rail 2. The rails 4 and 5 meet at 6 and near their meeting ends the point 7 of the frog 8 is placed.

The abutting ends of the rail sections 4 and 5 are connected to transversely moving rods, a part of the ends of which are passed through openings in the rails 3 and 4 and are connected to the bar or plate 10, in the housing or metal box 11. The bar or plate 10 is connected to an operating link or rod

12, one end of which is pivoted to the link 13 of the switch lever 14.

Coil springs 15 are mounted on the rods 9 so as to bear against the wall of the box 11 or the rail 3, and against the bar or plate 10, thereby normally holding the rail 4 against the main line rail 3 and the rail 5 away from the main line 1, and the main line open.

In order to operate the switch rails 4 and 5 the lever is rocked on its bearing and the rods 9 are moved transversely of the rails so that the rail 5 will abut against the rail 2 and the rail 4 will be moved away from the rail 3, thereby opening the switch.

In order to hold the switch rail 5 against the rail 2 and keep the switch or siding open the inner end of the link rod 12 is formed with a hook 16 which is engaged by the pivoted catch dog 17, one end of which engages the lever 18, pivoted to the bearing bracket 19, which is mounted on the end of the reciprocating link 20. The reciprocating link 20 extends substantially parallel with one of the main line rails and into the box 21, in which the track engaging abutment 22 is supported on the vertical sliding member 23, the lower end of which is connected to the lever 24, pivoted at 25 to the base plate of the standard 26. On the standard 26, which forms a guide for the sliding member or sleeve 23, a coil spring 27 is disposed, which bears at its upper end against the rail abutment 22. The lever 24 is formed with a long arm and a short arm, the short arm being disposed angularly to the long arm and pivoted to the reciprocating link 20 and the long arm being pivoted by a slotted plate 28 to the standard 26, so that the downward movement of the sleeve 23 will depress the longer arm of the lever and tilt the shorter arm, thereby moving the catch lever 18 away from the hook engaging dog 17, which holds the switch rails 4 and 5 in such position that the main line will be closed and the siding will be open. After the train or car has passed over the member 22 the lever catch 18 will be released from the dog 17 and the springs 15 will return the rails 4 and 5 to their normal positions. Carried by the rod 12 is an abutment 12^a, between which and the hook 16, one end of the dog 17 is arranged. By this connection the dog 17 may again be engaged by the latch 18, subsequently to the tripping of the latch, that is when the rod 12 is moved

in the direction of the rail 3, the dog 17 may be oscillated so that it will be engaged by the latch 18. The bar 12 moves through a guide 12^b as shown in Figs. 2 and 3, which
 5 guide acts as a stop to be engaged by the abutment 12^a, to limit the rod 12 in its movement in one direction.

As will be observed in Fig. 1 of the drawings the normal position of the switch points is as shown, thus leaving the main line open for traffic. When it is desired to switch a train on the siding or on another main line, the operating lever shown in Fig. 3 is manipulated, so as to throw the switch points
 10 or rails 4 and 5 in the direction of the main line rail 2. When the switch points or rails 4 and 5 are so thrown the hook 16 engages one end of the catch dog 17, while the other end of the catch dog 17 engages the notch
 15 in the lever 18, which holds the switch points or rails 4 and 5 in their abnormal positions, thus permitting the oncoming train to be switched on the siding or the other main line. As the train passes over the rails of the siding or the other main line the section of rail 21^a of the siding is depressed, and when so depressed, the lever 24
 20 is oscillated upon its pivot 25, which will reciprocate the link 20 in the direction of the arrow 20^a, which will release the lever 18 from engagement with the end of the catch dog 17, thus permitting the springs
 25 15 to restore the switch points or rails 4 and 5 to their normal positions, so that the main line will be again open, whereby the next train may pass on without taking the siding. It is to be understood, however,
 30 that the distance between the section of rail 21^a (which is depressed by the car wheels) and the switch mechanism is sufficient to admit of substantially the longest train,
 35 40

thus avoiding the possibility of the sectional rail 21^a being depressed, before the entire train has taken the siding.

Having described our invention we 45 claim:—

In combination, the main line rails, the siding rails and a pair of switch points or rails coöperating between the main line rails and the siding rails, spring tension
 50 means for holding the switch points or rails so that the main line remains normally open, a manually operated lever having a reciprocating rod connection for actuating spring
 55 tension means for throwing the switch points or rails to close the main line and open the siding, a catch dog engageable by the reciprocating rod for holding the switch
 60 points thrown, a pivoted lever to engage the catch-dog for holding the catch-dog whereby the switch points are held as thrown to close the main line, a reciprocating link
 65 connected to the pivoted lever, and a spring tension depressible member disposed beneath a section of rail of the siding, and
 70 having connection with the reciprocating link whereby the pivoted lever may be released from engagement with the catch dog, thus permitting the switch points to be restored
 75 to their normal positions by the spring tension means, said depressible spring tension member being actuated by the weight of a train when passing over the section of rail of the siding.

In testimony whereof we have signed our names to this specification in the presence of two subscribing witnesses.

DANIEL B. CAUDY.
 EDWARD K. CUTLIP.

Witnesses:

G. C. ALDERSON,
 F. N. ALDERSON.