

Sept. 14, 1965

L. W. MARTIN

3,205,617

GRAVITY TOY TRAIN

Filed Oct. 17, 1962

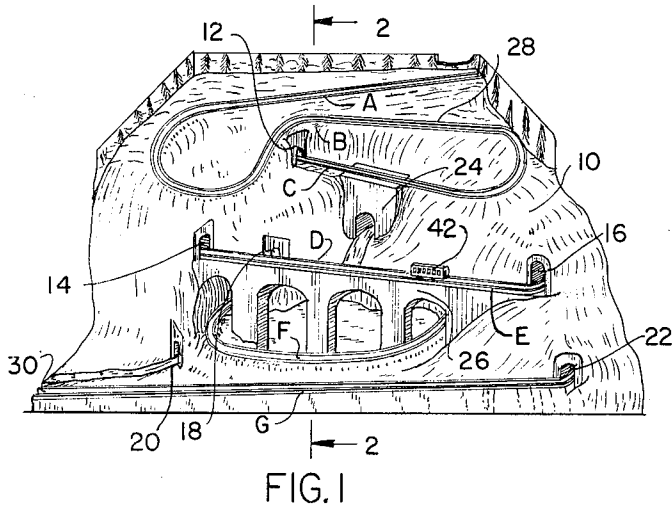

FIG. 1

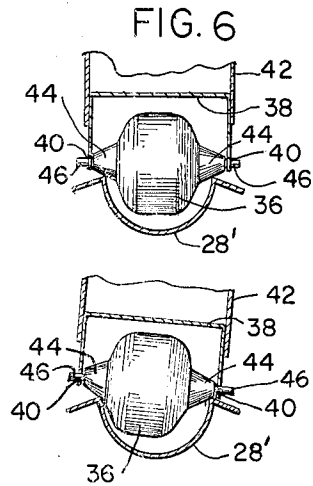

FIG. 7

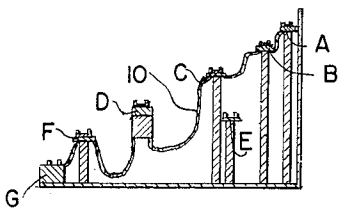

FIG. 2

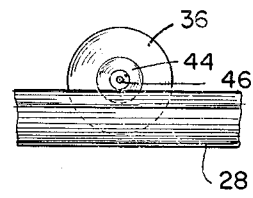

FIG. 5

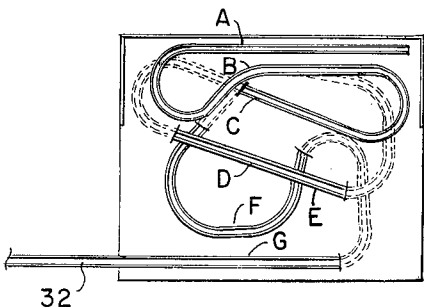

FIG. 3

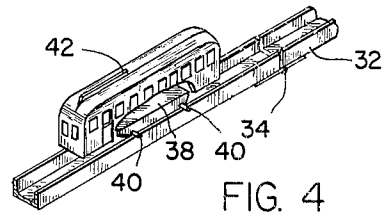

FIG. 4

INVENTOR  
LEWIS W. MARTIN

BY *Walter S. Paul*  
ATTORNEY

1

3,205,617

## GRAVITY TOY TRAIN

Lewis W. Martin, Rte. 3, Box 288B, Manheim, Pa.

Filed Oct. 17, 1962, Ser. No. 231,065

1 Claim. (Cl. 46-218)

This invention relates to gravity propelled toy trains and inclined winding tracks therefor, laid in and through a mountainous landscape.

The object of this invention is to provide a low price miniature landscape having a mildly inclined circuitous track weaving in and out of tunnels for a toy train propelled by gravity for the amusement of children and grown-ups who might be interested in model railroading.

A further object is to provide a novel inertia traction means for said train which will carry the train around the curved portions of the track without losing any significant portion of the speed gained on the straightaways between the curved portions.

A further object is to construct a toy car having high mass wheels and a light car shell to minimize bearing friction due to loading, and to maximize the inertia of rotation of the traction means.

A further object is to provide substantially spherical mass axles between comparatively small conical wheels extending from opposite sides of the spherical or ellipsoidal or other ball-shaped mass and having spindles at their apexes freely mounted in loose bearings in the lower edge of the sides of the car shell, so that the car banks properly in going around the curved portions, where the wheels are shifted on the tracks to the outside of the curve, the outer track engaging a larger diameter of the outer wheels and the inner track, a smaller diameter of the inner wheels; thus also reducing wheel slippage, by compensating for the longer outer track with a larger wheel diameter.

A further object is to form a continuous winding channel having level edges to serve as tracks of minimum width for said conical wheels, said tracks being spaced a distance substantially equal to the length of the mass axle between the bases of the conical wheels, said tracks being spaced a distance substantially equal to the length of the mass axle between the bases of the conical wheels plus the width of one of said wheels, and to support said channel on and through a paper-mache landscape with mountains and tunnels arranged so that the tracks going down the mountain slopes and through said tunnels will have a mild incline throughout their entire length.

A further object is to construct a straight extension channel for use between two landscapes of the above type to guide a toy train for continuous operation through both landscapes.

Other and more specific objects will appear in the following detailed description of one form of this invention, as illustrated in the accompanying drawing, wherein:

FIG. 1 is a front perspective view of a landscape and track made in accordance with the present invention,

FIG. 2 is a sectional elevational view taken on the line 2-2 of FIG. 1,

FIG. 3 is a plan view of the track by itself, showing its hidden portions in dotted lines,

FIG. 4 shows a toy car with one side broken away to show a wheel truck structure on which the car shell is mounted, and a portion of a foldable track extension,

FIG. 5 is a side view of a wheel mass by itself on a portion of a track,

FIG. 6 is an enlarged vertical sectional view taken through a portion of the car and tracks at one of the wheel bearings, and

FIG. 7 is a similar sectional view showing the wheels shifted to one side producing a banking of the car.

2

The invention combines three main parts or combination of parts.

(1) A vehicle with especially designed rollers or wheels in pairs to run over a track like the wheels and axles of railroad cars, with the exception that in this case the axle is larger in diameter than the wheels, said axle acting as a flywheel providing a momentum to the rolling wheels to carry said vehicle over the track, whether straight or curved, with a minimum of incline and speed. The shape of said axle provides easy mounting of the vehicle on the track, and also provides a low center of gravity so that there is little chance of the vehicle jumping the track.

(2) A track, especially designed for said wheel and axle assemblies with enough depth to accommodate the large flywheel type axle, said track and wheel assemblies being designed to create a minimum of friction.

(3) A base for said track, in the shape of landscape scenery, said base being laid in different parts so that one track may cross above another track, said base forming hills and valleys so that tunnels and bridges can be used to form a long, intricate and interesting track system in a small space.

The aforesaid track could be made in sections, straight and curved, with suitable connecting contrivances, to make or connect different bases so as to join a variety of systems together in series, so that a train could be made to traverse several bases successively.

One form of mountainous landscape base is illustrated in FIG. 1, wherein a paper-mache landscape surface 10 is formed to represent hills and valleys, with tunnel openings at 12, 14, 16, 18, 20 and 22, and bridges at 24 and 26.

A continuous inclined track 28 extends from the top, over the surface through points A, B and over a bridge 24 through C into a tunnel at 12, out at 14, through the point D over bridge 26, into a tunnel at 16, through the point E, out at 18, under bridge 26 twice through point F, into another tunnel at 20, out at 22 and over the surface through point G to the lower end of the track at 30, which is open and is adapted to receive an extension channel 32 for guiding a train to the top of another landscape base, if desired. Long extension channels may be made hinged as shown at 34 in FIG. 4, so that they may be folded for easier handling.

The sectional view of FIG. 2 shows the successively lower levels at which the track is supported at points A, B, C, D, E, F and G, to provide the continuous incline of the track, the plan view of which may be seen in FIG. 3.

The novel traction means for the car shown comprise a pair of mass axles 36 mounted in a truck frame 38 in loose bearings 40. The car shell 42 is a light weight sheet formed like a car body, and may be made integral with the truck frame or may be fixed thereto by a friction fit or otherwise as shown in FIGS. 6 and 7. The conical wheels 44 extend from opposite ends of the mass axles 36 and have spindle journals 46 at their apexes mounted loosely in the bearings 40.

The channels 32 are rectangular in section. However, they may be made in any other suitably deep channel form to accommodate the mass axles, as e.g. the form 28' shown in FIGS. 6 and 7.

It will be noted that in going around the curved portions of the tracks, the inertia of the car as a whole will cause the wheels to shift to one side of the tracks as shown in FIG. 7, but the mass axle will serve as a wheel flange and will prevent the wheels from jumping the track, but will not cause any additional flange friction, because the narrow track makes substantially only a point contact with the round groove at the base of the outer wheel just as it does normally with other parts of the conical surface of

3

the wheel. The shifting of the wheels toward the outer side of the curved portions raises that side of the car while lowering the other side, thus shifting the low center of gravity toward the inside track to bank the car properly in going around the curve, preventing its tipping over the outside track at high speeds. The greater diameter in contact with the outer track, furthermore, compensates for the longer track and reduces slippage friction to a great extent. Thus, a very efficient traction operation is obtained, permitting gravity to provide the necessary motive power using a very small incline gradient, and thus a longer and more winding track in a smaller area of landscaping and having less overall drop in level.

Many obvious modifications in the details and arrangement of parts may be made without departing from the spirit and scope of the present invention, as defined in the appended claim.

What is claimed is:

A toy car and track device comprising a backing frame having a flat bottom and a back forming a recess, an artificial landscape built over said recess representing a mountainous region in miniature generally sloping from the top of said back to the front of said bottom, a long track having a substantially continuous small gradient and winding back and forth across said landscape with straightaways between curved portions, from an upper level on the surface of said landscape, through tunnels in the sides of the mountains and

4

over bridges spanning valleys therein, to the side of said frame at the bottom of said landscape, and an efficient gravity operated toy car having ball-shaped rolling inertia mass with small diameter wheels to counteract deceleration around curved portions and roll it down the entire length of said track without additional power at a substantially even speed,

said wheels comprising outwardly tapering conical portions formed on a common massive axle portion comprising said ball-shaped mass between each pair of wheels and having journals extending outwardly of said wheels for mounting in bearings at the sides of the car,

said car having a frame, bearings mounted in the sides of said frame, said journals mounted in said bearings, said track having sharp and uniformly spaced rail edges for substantially point contacts with the conical wheels at the same level at the opposite ends of each massive axle portion.

**References Cited by the Examiner**

**UNITED STATES PATENTS**

789,946	5/05	Turpin	104—63
837,040	11/06	Clark	46—209
1,776,262	9/30	Le Noir et al.	238—10
3,074,206	1/63	Fischl-Bernfi	273—109

RICHARD C. PINKHAM, *Primary Examiner.*