

(19) World Intellectual Property  
Organization  
International Bureau



(43) International Publication Date  
3 February 2005 (03.02.2005)

PCT

(10) International Publication Number  
**WO 2005/009125 A1**

(51) International Patent Classification<sup>7</sup>: **A01N 1/02**

(21) International Application Number:  
PCT/NL2004/000539

(22) International Filing Date: 27 July 2004 (27.07.2004)

(25) Filing Language: Dutch

(26) Publication Language: English

(30) Priority Data:  
1024022 30 July 2003 (30.07.2003) NL

(71) Applicant (for all designated States except US): **TECHNOLOGIESTICHTING STW** [NL/NL]; Van Vollenhovenlaan 661, NL-3527 JP Utrecht (NL).

(72) Inventors; and

(75) Inventors/Applicants (for US only): **VAN DER**

**PLAATS, Arjan** [NL/NL]; Kortenaerstraat 10, NL-9726 HK Groningen (NL). **VERKERKE, Gijsbertus, Jacobus** [NL/NL]; Hoge Hereweg 13, NL-9756 TG Glimmen (NL). **RAKHORST, Gerhard** [NL/NL]; Esserweg 2, NL-9722 SN Groningen (NL). **PLOEG, Rutger, Jan** [NL/NL]; Wilhelminalaan 1, NL-9752 LL Haren (NL). **T HART, Nils, Arnaud** [NL/NL]; Wachtel 7, NL-9247 GL Ureterp (NL). **LEUVENINK, Hendrik, Gerrit, Derk** [NL/NL]; Volmachten 28, NL-9481 HN Vries (NL).

(74) Agent: **WINCKELS, J., H., F.**; Nieuwe Parklaan 97, NL-2587 BN Den Haag (NL).

(81) Designated States (unless otherwise indicated, for every kind of national protection available): AE, AG, AL, AM, AT, AU, AZ, BA, BB, BG, BR, BW, BY, BZ, CA, CH, CN, CO, CR, CU, CZ, DE, DK, DM, DZ, EC, EE, EG, ES, FI, GB, GD, GE, GH, GM, HR, HU, ID, IL, IN, IS, JP, KE, KG, KP, KR, KZ, LC, LK, LR, LS, LT, LU, LV, MA, MD, MG, MK, MN, MW, MX, MZ, NA, NI, NO, NZ, OM, PG, PH, PL, PT, RO, RU, SC, SD, SE, SG, SK, SL, SY, TJ, TM,

[Continued on next page]

(54) Title: PORTABLE PRESERVATION APPARATUS FOR A DONOR ORGAN

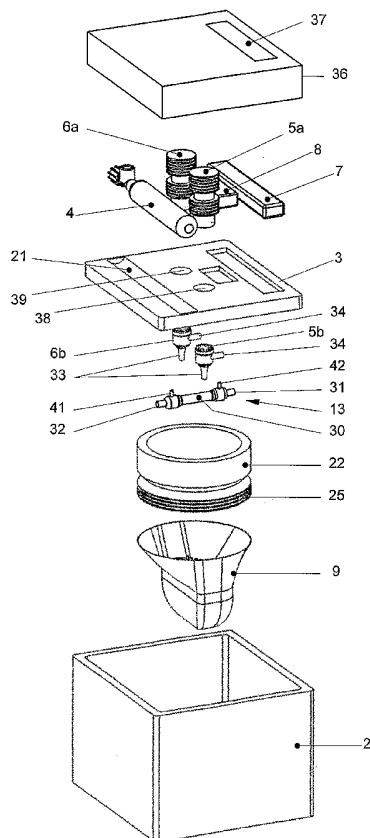

(57) Abstract: A portable preservation apparatus of the cold storage type for a donor organ, comprising a cooling box provided with an organ chamber for receiving a donor organ in preservative fluid and a lid, wherein, on the side which operatively faces the organ chamber, the lid is provided with a connector which is detachably connected to the lid, which connector is provided with passages for one or more connecting pieces connected with the donor organ and one or more pipes connected with at least one perfusion pump, wherein the at least one perfusion pump is a miniature pump mounted at least partly in the lid and wherein the apparatus further comprises at least one oxygenator, an oxygen container, one or more electronic modules and a power supply module.

WO 2005/009125 A1



TN, TR, TT, TZ, UA, UG, US, UZ, VC, VN, YU, ZA, ZM, ZW.

**(84) Designated States** (unless otherwise indicated, for every kind of regional protection available): ARIPO (BW, GH, GM, KE, LS, MW, MZ, NA, SD, SL, SZ, TZ, UG, ZM, ZW), Eurasian (AM, AZ, BY, KG, KZ, MD, RU, TJ, TM), European (AT, BE, BG, CH, CY, CZ, DE, DK, EE, ES, FI, FR, GB, GR, HU, IE, IT, LU, MC, NL, PL, PT, RO, SE, SI, SK, TR), OAPI (BF, BJ, CF, CG, CI, CM, GA, GN, GQ, GW, ML, MR, NE, SN, TD, TG).

**Published:**

— with international search report

— before the expiration of the time limit for amending the claims and to be republished in the event of receipt of amendments

*For two-letter codes and other abbreviations, refer to the "Guidance Notes on Codes and Abbreviations" appearing at the beginning of each regular issue of the PCT Gazette.*

Title: Portable preservation apparatus for a donor organ

The invention relates to a portable preservation apparatus for a donor organ, comprising a cooling box provided with an organ chamber for receiving a donor organ in preservative fluid and a lid.

The invention is particularly but not exclusively suitable for  
5 preservation of a donor liver or a donor kidney. The following will focus on use for a donor liver. For other organs, an adjustment to the specific structure of these organs is needed.

The transplantation procedure of a liver comprises three stages, viz.  
1) the donor operation, 2) the organ preservation and the transport and  
10 3) the implantation in the recipient. The donor operation consists of cannulating the arteria hepatica (HA) and the portal vein (PV), via which the liver is then washed with the aid of a cold (4°C) fluid, such as for instance the University of Wisconsin preservation (UW fluid). After washing, the cold UW fluid remains in the liver and the liver is packaged in  
15 a plastic bag filled with extra UW fluid and tied up. Around this, a second bag is provided which has been filled with cold physiological salt and then a third bag for extra strength and sterility. This whole is then placed in a portable cooling box which has been filled with melting ice and is then closed. This manner of preservation is called the 'static cold storage' (CS)  
20 and is the current standard method for liver preservation. After maximally approx 12 hours, the liver is to be implanted in the receiving patient. This is done by connecting the blood vessels of the donor liver with the vessels of the recipient and then washing the donor liver clean with a special fluid or the blood of the patient. After this, complete reperfusion of the liver takes  
25 place.

Drawbacks of this procedure are that the period of time of 12 hours is not very long, and that intermediate analysis of the viability and the condition which the liver is in is not possible.

The invention contemplates providing an improved preservation apparatus which is based on the known cold storage method, but reduces the drawbacks associated therewith. For this purpose, according to the invention, a portable preservation apparatus of the above-described type is characterized in that, on the side which operatively faces the organ chamber, the lid is provided with a connector detachably connected to the lid, which connector is provided with passages for one or more connecting pieces connected with the donor organ and one or more pipes connected with at least one perfusion pump, where the at least one perfusion pump is a miniature pump mounted at least partly in the lid and where the apparatus further comprises at least one oxygenator, an oxygen container, one or more electronic modules and a power supply module.

An advantage of the apparatus according to the invention is that the actions to be performed by the surgeon who performs the donor operation conveniently fit the already established CS routine, so that the risk of errors is small. Also, the apparatus according to the invention can be designed as a really portable apparatus, which simplifies the practical application of the apparatus. It is further possible to intermediately take samples to determine the quality of the donor organ present in the apparatus according to the invention.

It is noted that research concerning kidney transplantations has shown that, when a kidney is continuously perfused by means of a pump system during the cold preservation stage, the preservation period can be considerably extended. Continuous perfusion also makes it possible to take intermediate samples of the fluid and to monitor perfusion characteristics. It has further been found that the quality of continuously perfused kidneys is considerably better than that of statically stored kidneys, so that it

appears possible to use kidneys of poorer quality for transplantation as well, such as for instance kidneys of donors who had a cardiac arrest. This would considerably increase the 'donor pool'.

A preservation apparatus provided with a pump system for  
5 continuous perfusion of kidneys or livers is described in WO 0133959. The pump system used in this known apparatus comprises a compressed air-driven membrane pump apparatus, which comprises a first fluid tank with supply and discharge pipes and which, in turn, has been placed in a second fluid tank. The second fluid tank is located below the reception space  
10 for an organ to be preserved. The membrane pump apparatus is arranged such that compressed air used for the drive is also utilized to aerate the fluid in the second fluid tank. Although this known preservation apparatus has a relatively simple construction, it is fairly sizeable and therefore difficult to transport.

15 Further, from US-A-6046046 and US-A-6100082, a perfusion apparatus is known for preserving a donor organ in functioning condition during a preservation period. For this purpose, the donor organ is placed in a container filled with a preservative fluid, while, further, via one or more main arteries and/or veins, preservative fluid is passed through the organ.  
20 This known apparatus is also fairly sizeable and has been mounted in a mobile cart. The known apparatus is not portable. Also, in the known apparatus, the donor organ is not cooled. Further, the known apparatus has in the first instance been designed for preserving a donor heart, but in US-A-6046046, applications for other organs, such as kidneys and livers, are  
25 also mentioned. Also, the use of this known apparatus demands relatively much adaptation of the surgical team, which stands in the way of an application on a larger scale.

In the following, the invention will be further described with reference to the appended drawing of an exemplary embodiment, in which:

Fig. 1 diagrammatically shows, in perspective view, an example of a portable preservation apparatus according to the invention in closed condition;

Fig. 2 shows a block diagram of an example of a portable preservation  
5 apparatus according to the invention;

Fig. 3 shows a similar diagram to Fig. 2, in which the single-use and multiple-use parts, respectively, are shown;

Fig. 4 diagrammatically shows, in perspective view, the lid of the apparatus of Fig. 1 with the parts of the preservation apparatus fastened  
10 thereto;

Fig. 5 shows a similar view to Fig. 5 but without the lid;

Fig. 6 diagrammatically shows, in perspective view, a connector of a preservation apparatus according to the invention; and

Fig. 7 diagrammatically shows, in perspective view, the preservation  
15 apparatus of Fig. 1 in exploded view.

Fig. 1 diagrammatically shows, in perspective view, an example of a preservation apparatus 1 according to the invention. The apparatus shown comprises a cooling box 2 with a lid 3 drawn in the closing position in Fig. 1. On and in the lid 3, a number of components of the apparatus has been  
20 mounted, such as an oxygen container in the form of an oxygen cylinder 4, two small perfusion pumps 5,6 and modules 7,8 with control electronics, a power supply, etc. The power supply preferably comprises at least one battery, but may also comprise means such as for instance a transformer, a rectifier, a DC-DC converter etc., which are arranged to be able to offer  
25 electric energy in the suitable form, optionally from the electricity grid, to the control electronics and the pumps etc.

Fig. 2 shows a block diagram of an example of a portable preservation apparatus according to the invention. In an organ chamber 10 formed in the cooling box 2, an organ L to be transplanted is present during use. This  
30 specification focuses on a liver to be transplanted, but the portable

preservation apparatus according to the invention is also suitable for other organs such as for instance a kidney. During the donor operation, the liver is placed in a plastic bag 9 filled with preservative fluid. This bag has been placed in a second bag filled with physiological salt to prevent freezing  
5 damage. For safety reasons, usually a third bag is provided around the second bag. The thus packaged liver is placed in the organ chamber 10. During the donor operation, the portal vein (vena portae) and the arteria hepatica of the liver are provided with cannulas which are, in this example, each connected with the pumps 5,6 of Fig. 1 via an oxygenator 13,14. The  
10 hepatic vein ends in the bag 9 from which the pumps 5,6 suck in the perfusion fluid via one or more pipes 18 so that it can be recirculated. In Fig. 2, the pump 5 connected either directly or via a connecting tube 11 with the cannula of the arteria hepatica is designated by AH and the pump 6 connected either directly or via a connecting tube 12 with the vena portae is  
15 designated by VP. The pump 6 is connected with the vena portae via an oxygenator 13 (VP oxy). If desired, the pump 5 can also be connected either directly or via a second oxygenator (AH oxy), designated by 14, with the arteria hepatica. The pumps are preferably designed such that, selectively, either a continuous working mode or a pulsatile working mode is possible,  
20 so that, physiologically optimal perfusion conditions can be achieved. The connections which would be required for a different organ depend on the specific organ. For a kidney, for instance, only one connection with only one pump to the organ is required.

Fig. 2 also shows a control device 15, which controls the pumps 5  
25 and 6 in response to the pressure P detected by means of pressure sensors 16,17 after the VP oxygenator 13, and after the pump 5, or, if present, the second oxygenator 14. The control device 15 is also connected with a microprocessor or a minicomputer, for instance a so-called palmtop computer 19, which is provided with a display screen and which is arranged

to display relevant information, such as pressure in the cannulas, flow velocity and/or flow rate, temperature, time, alarm condition etc.

The display screen, any operating buttons or switches, indicator lamps and the like may, if desired, have been provided in a cover placed on  
5 the lid, which is diagrammatically shown in Fig. 7, designated by 36. Such a cover may of course also have a window 37 and/or flaps, behind which a display screen, buttons and the like are found.

Fig. 3 shows a similar diagram to Fig. 2, in which the single-use parts are designated by D and the parts which are reusable after use by H.

10 The reusable parts comprise the driving motors 5a (AHa) and 6a (VPa) of the pumps 5 and 6, respectively, for the arteria hepatica and the vena portae, respectively. The reusable parts further comprise the electronics E, the minicomputer 19 or the like and the oxygen cylinder 4, which is, via pipes 20,21,22, connected with the oxygenator VP oxy and, if  
15 present, with the oxygenator AH oxy.

The single-use parts D comprise the parts of the pumps 5 and 6 which come into contact with the perfusion fluid. These are the parts 5b (AHb) and 6b (VPb) of the pumps. The oxygenator 13 for the vena portae and, if present, the oxygenator 14 for the arteria hepatica are also used only once.  
20 The same holds true for the pipes 18 between the organ bag 9 and the pump parts 5,6.

Fig. 4 diagrammatically shows the lid 3 of the cooling box 2 with the parts fastened to the lid and Fig. 5 shows these parts without the lid 3. As Fig. 4 shows, an oxygen cylinder 4 has been mounted on the lid 3. In this  
25 example, the oxygen cylinder is located in a recess 21 in the lid. The pipe(s) connected with the oxygen container which lead to the oxygenator(s) are not shown. On the lid, further, the reusable parts 5a and 6a of the pumps 5 and 6 have been mounted. Under the lid, a connector 22 has been mounted. The connector is detachably connected with the lid via a snap connection, a  
30 bayonet catch, a magnetic connection or the like. In the example shown, the



connector has the shape of a short cylinder 23 closed at one end, as Fig. 6 shows best. The closed side or bottom of the connector faces the organ chamber. The bottom 24 is provided with passages and/or connecting pieces 11,12 for the cannulas and for the pipes coming from the oxygenator(s) and for the suction pipe(s) 18 of the pumps 5 and 6. In the connector, so-called disposable pump heads 5b,6b, intended for single use and the oxygenator(s) 13, 14 are mounted. In the example of Fig. 6, only one oxygenator 13 is used for the vena portae. In use, under the connector, an organ bag 9 or a system of bags, as described hereinabove, has been fastened. In one of the manners known for this purpose, the organ bag 9 has been fixed on the connector 22, for instance with a so-called purse-string closure. Around this, an extra fastening, for instance a so-called tie-wrap, may be used. In the example shown, for obtaining a good closure, the connector is provided with a number of circular circumferential grooves 24 or ribs, respectively. A suitable organ bag is the Vi-Drape organ bag of Medical Concepts Development in St. Paul MN (USA). In a test arrangement, further, for the vena portae and the arteria hepatica, cannulas were used of Sherwood Medical in Tullamore (Ireland) and pumps with a motor of the type Deltastream DP2 and a pump head for single use of MEDOS Medizintechnik AG, in Stolberg (Germany).

The pump motor can be snapped on the pump head via an opening in the lid 3, for instance by using a magnetic coupling or the like. Alternatively, other commercially available miniature pumps, such as for instance the impella pump of Impella Cardiotechnik AG, in Aken (Germany), can be used.

All parts of the preservation apparatus which come into contact with the perfusion fluid have been mounted in the connector, with the exception of the organ bag. Thus, the connector with the parts connected thereto can be treated as a single-use replacement part.

The oxygenator 13 partly visible in Fig. 6 and wholly visible in Fig. 7 comprises a tubular body 30 filled with fibers with, at one end, an inlet connection 31 connected with the pump 6 and, at the other end, an outlet connection 32, connected with the cannula 12 during use. Via the vertical (in the drawing) connection pipes 41,42, oxygen is passed through the tubular body from the oxygen cylinder 4 in counterflow. Optionally, the oxygen supply may take place intermittently.

In this example, the pump heads 5b and 6b have an axial suction inlet 33, which is in connection with the organ chamber, and a radial discharge outlet 34, which is connected with the inlet connection 31 of the oxygenator 13 on the vena portae side. On the arteria hepatica side, the discharge outlet 34 of the pump head 6b can be connected either directly with the corresponding cannula 11 or with the inlet connection 31 of the oxygenator 14, depending on the fact whether a second oxygenator 14 is used.

Fig. 7 diagrammatically shows, in perspective, in exploded view, a portable preservation apparatus according to the invention. Also in Fig. 7, only one oxygenator 13 is shown but, as already noted, two oxygenators can be used. Fig. 7 also shows the openings 38,39 in the lid 3, which make it possible to fasten the pump motors 5a,6a on the pump heads 5b,6b. Further, receiving cavities 39,40 are shown for modules 7 and 9.

It is noted that, after the foregoing, various variants are obvious to a skilled person. As already noted before, a portable preservation apparatus according to the invention is also suitable for transporting and perfusing different organs than a liver. In that case, the number of cannulas, pumps and oxygenators needs to be adjusted.

Further, the connector may also have a different cross-sectional shape than the circular shape shown, for instance an oval shape. Also, in a practical embodiment, the apparatus will be provided with one or more

handgrips, carrying handles, running wheels and the like, which are not shown in the drawings.

For obtaining the desired cooling, the cooling box may be filled with ice and/or passive cooling elements and/or provided with a cooling device  
5 running on electricity or gas. It is further noted that a number of the parts<sup>\*</sup> mounted in or to the lid according to the foregoing specification may also be mounted in one or more fixed walls, or in a detachable part of a fixed wall. It is finally noted that the cooling box may also be used without cooling as a stove for, for instance, storing an organ at 37°C.

## CLAIMS

1. A portable preservation apparatus of the cold storage type for a donor organ, comprising a cooling box provided with an organ chamber for receiving a donor organ in preservative fluid and a lid, characterized in that, on the side which operatively faces the organ chamber, the lid is  
5 provided with a connector detachably connected to the lid, which connector is provided with passages for one or more connecting pieces connected with the donor organ and one or more pipes connected with at least one perfusion pump, wherein the at least one perfusion pump is a miniature pump mounted at least partly in the lid and wherein the apparatus further  
10 comprises at least one oxygenator, an oxygen container, one or more electronic modules and a power supply module.
2. A portable preservation apparatus according to claim 1, characterized in that the connector has the form of a container open on one side, and is provided with fastening elements which can cooperate with fastening  
15 elements provided to the lid for fastening the connector to the lid in such a detachable manner that the open side faces the lid, while the passages are located in an otherwise closed wall facing the organ chamber.
3. A portable preservation apparatus according to claim 1 or 2, characterized in that the at least one oxygenator, at least the part of the at  
20 least one perfusion pump coming into contact with the preservative fluid and the corresponding fluid pipes are mounted in the connector, so that, together with the said parts, the connector forms a single-use replacement part.
4. A portable preservation apparatus according to any one of the  
25 preceding claims, characterized in that the at least one perfusion pump is a pump with a detachable driving motor, which driving motor is, in mounted condition, located on the side of the lid facing away from the connector and

is detachably connected with the remaining part of the pump via an opening in the lid, which remaining part of the pump has been mounted in the connector.

5. A portable preservation apparatus according to any one of the  
5 preceding claims, characterized in that the lid is provided with at least one or more electronic modules and/or an oxygen container.

6. A portable preservation apparatus according to any one of the  
preceding claims, characterized in that the electronic modules comprise a  
minicomputer for controlling the pumping action of the at least one pump  
10 and the displaying of relevant data.

7. A portable preservation apparatus according to any one of the  
preceding claims, characterized by a cover to be placed on the lid, which at  
least partly forms a window for a display screen.

8. A portable preservation apparatus according to any one of the  
15 preceding claims, characterized in that, on the outside, near the wall facing the organ chamber, the connector is provided with a number of circumferential grooves and/or ribs for fastening an organ bag.

9. A portable preservation apparatus according to any one of the  
preceding claims, characterized in that the cooling box is provided with one  
20 or more handgrips and/or carrying handles.

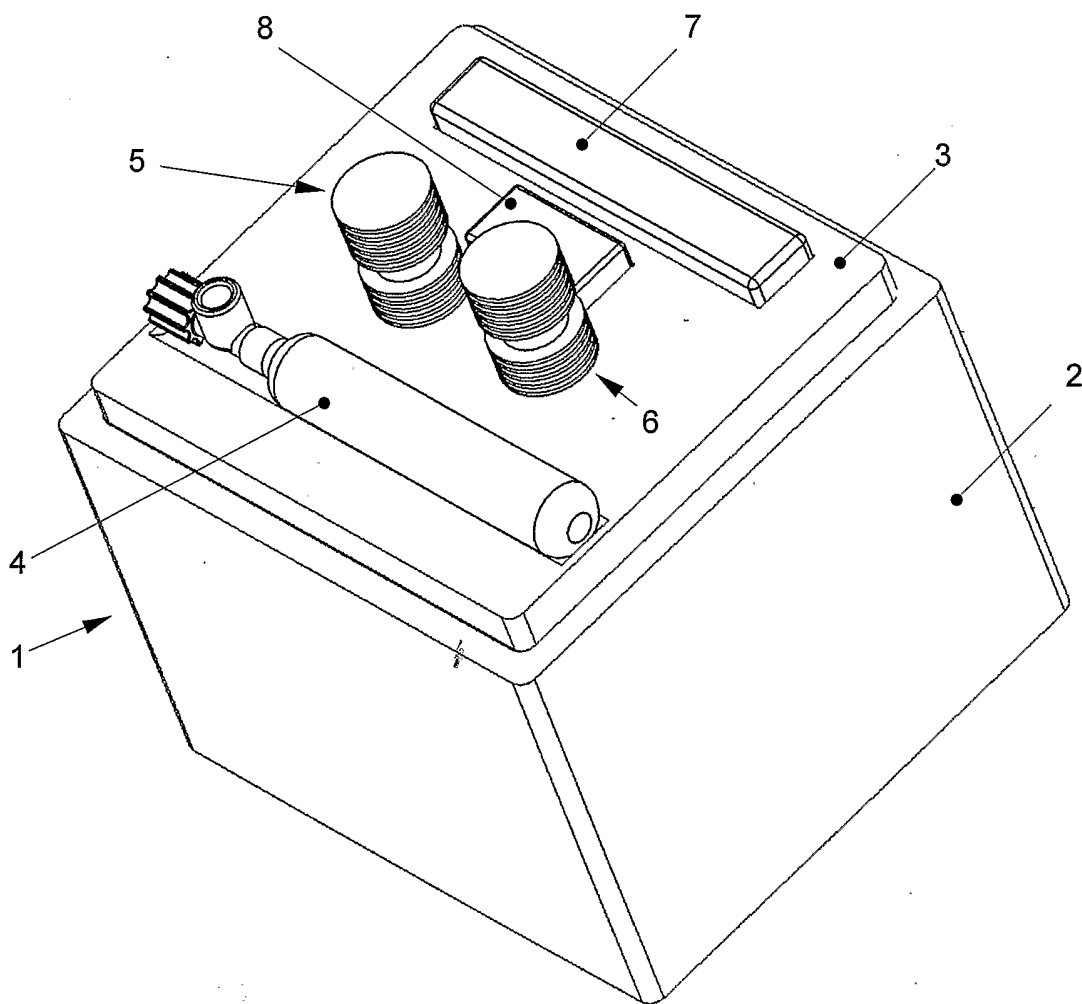

Fig. 1

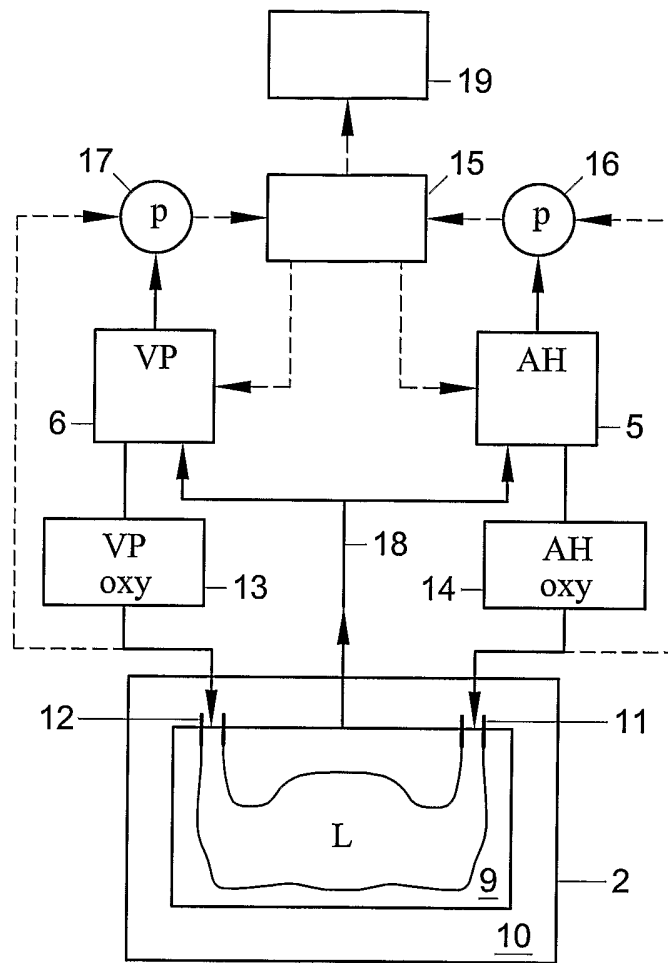

Fig. 2

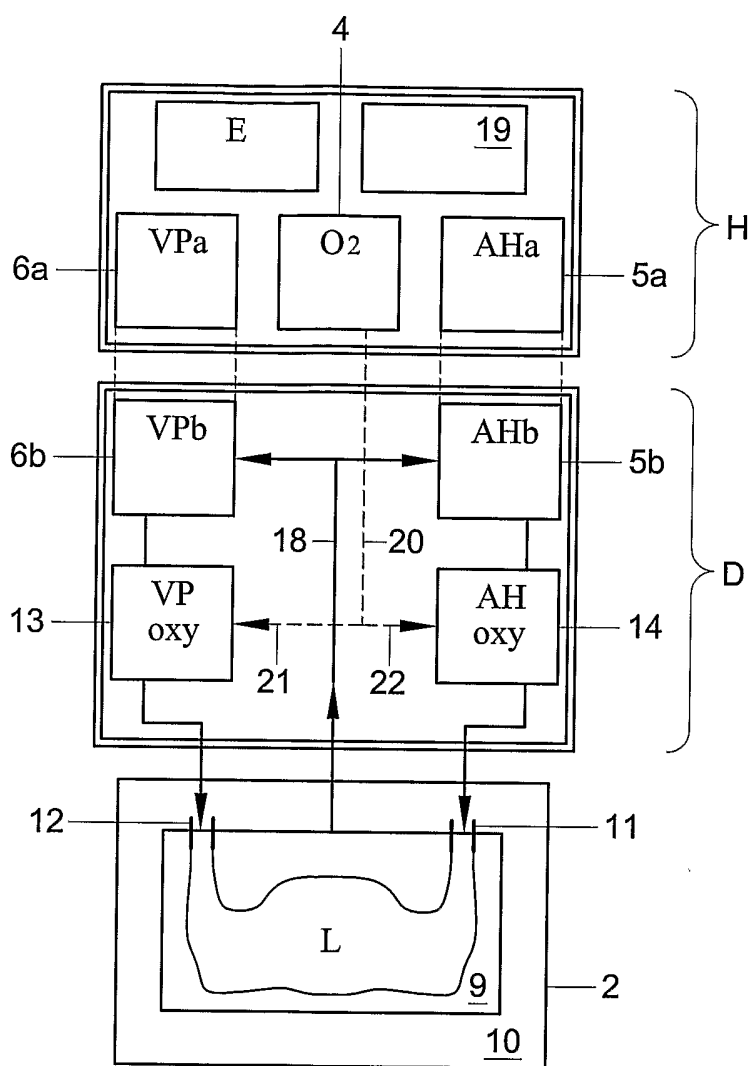

Fig. 3



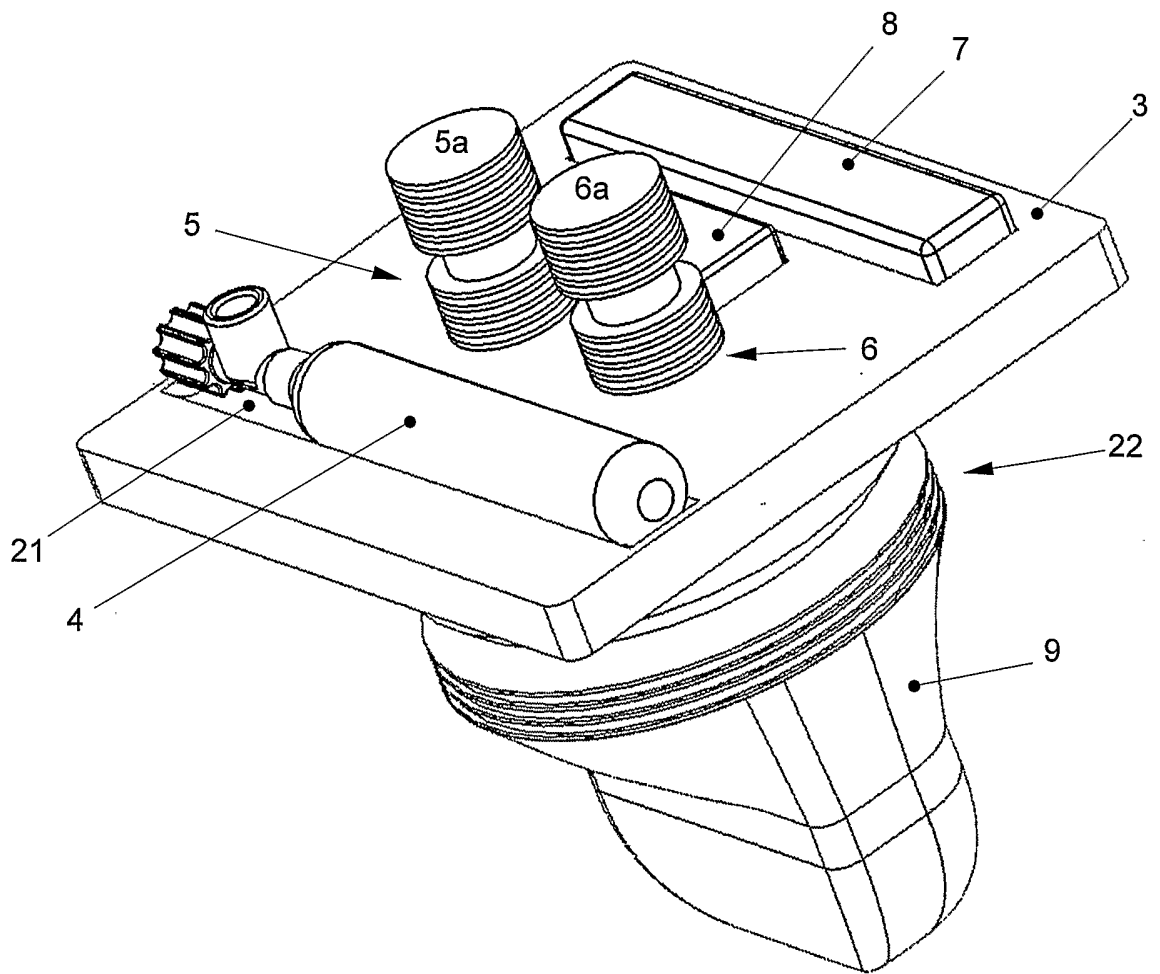

Fig. 4

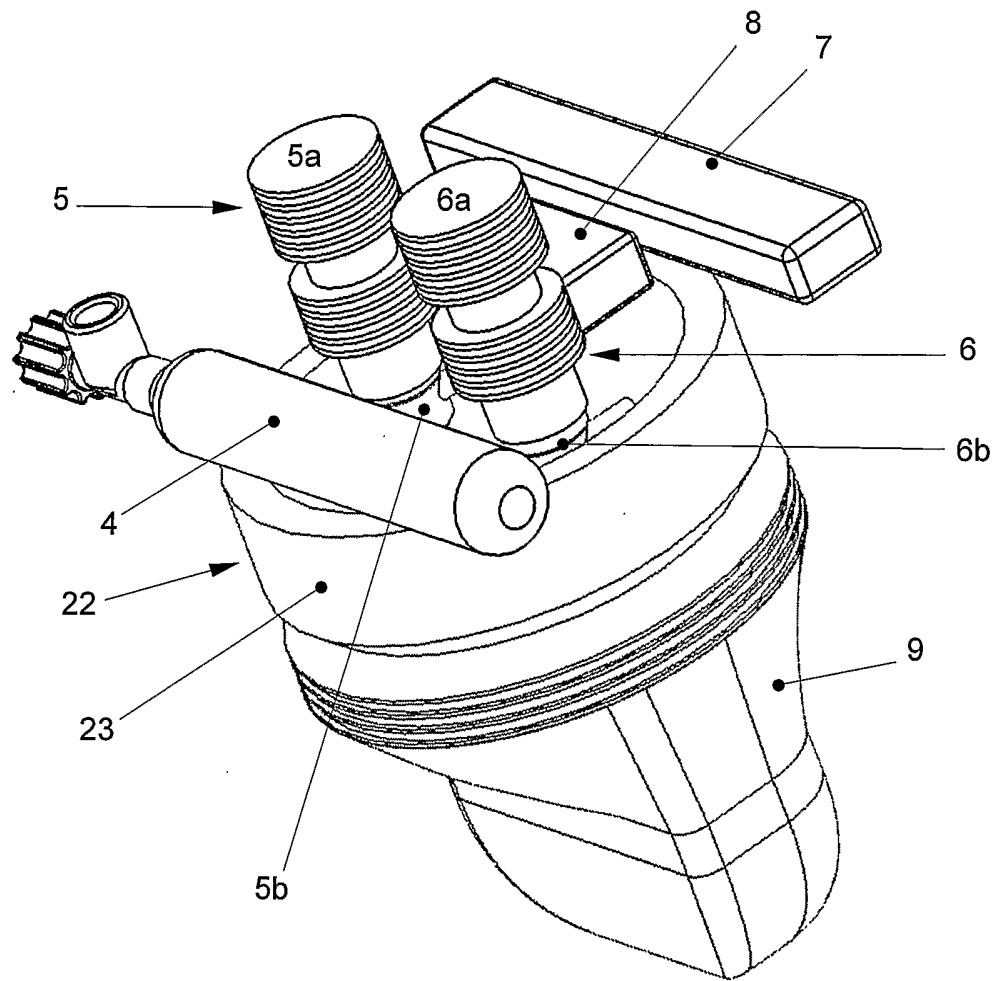

Fig. 5

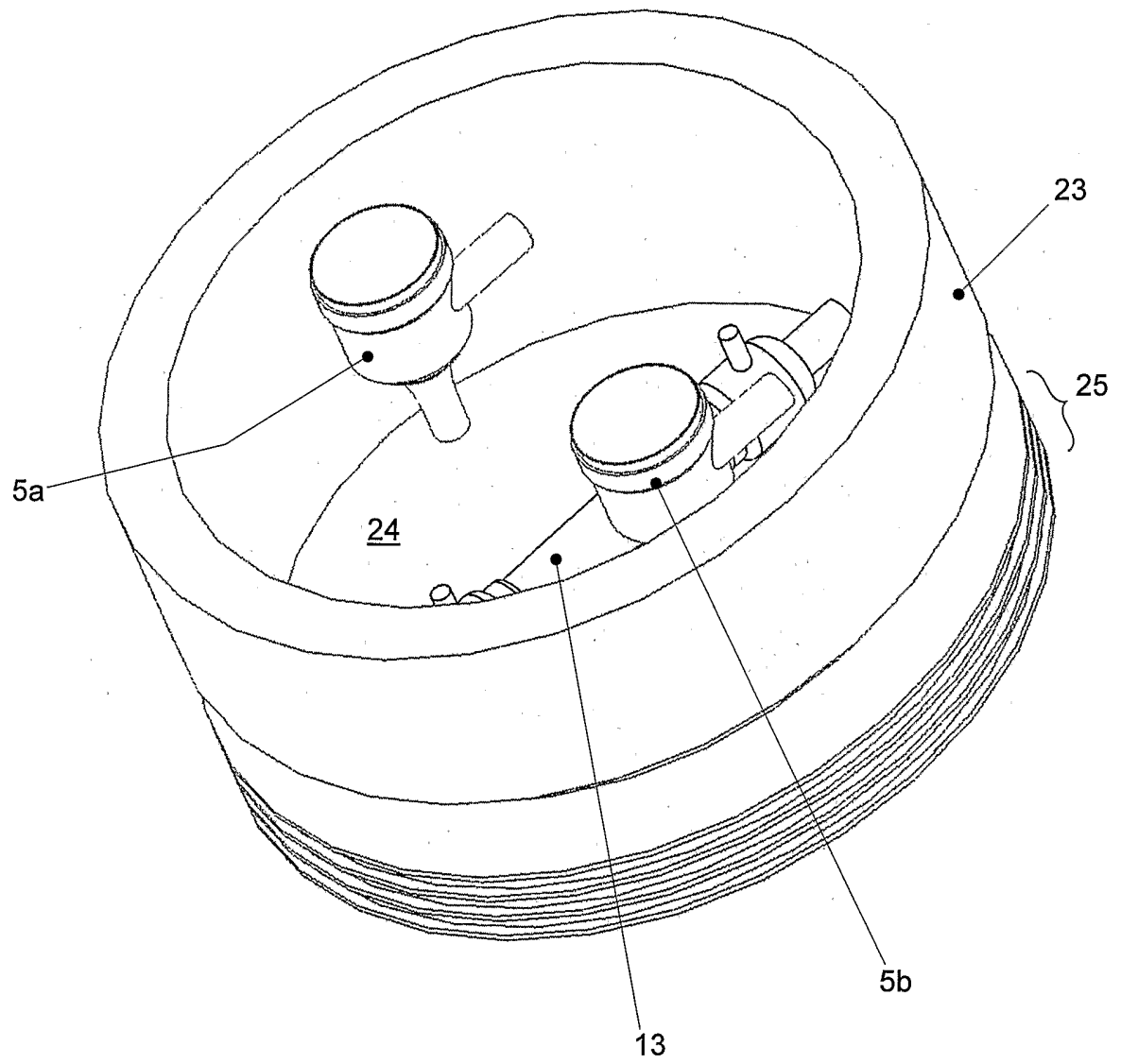

Fig. 6

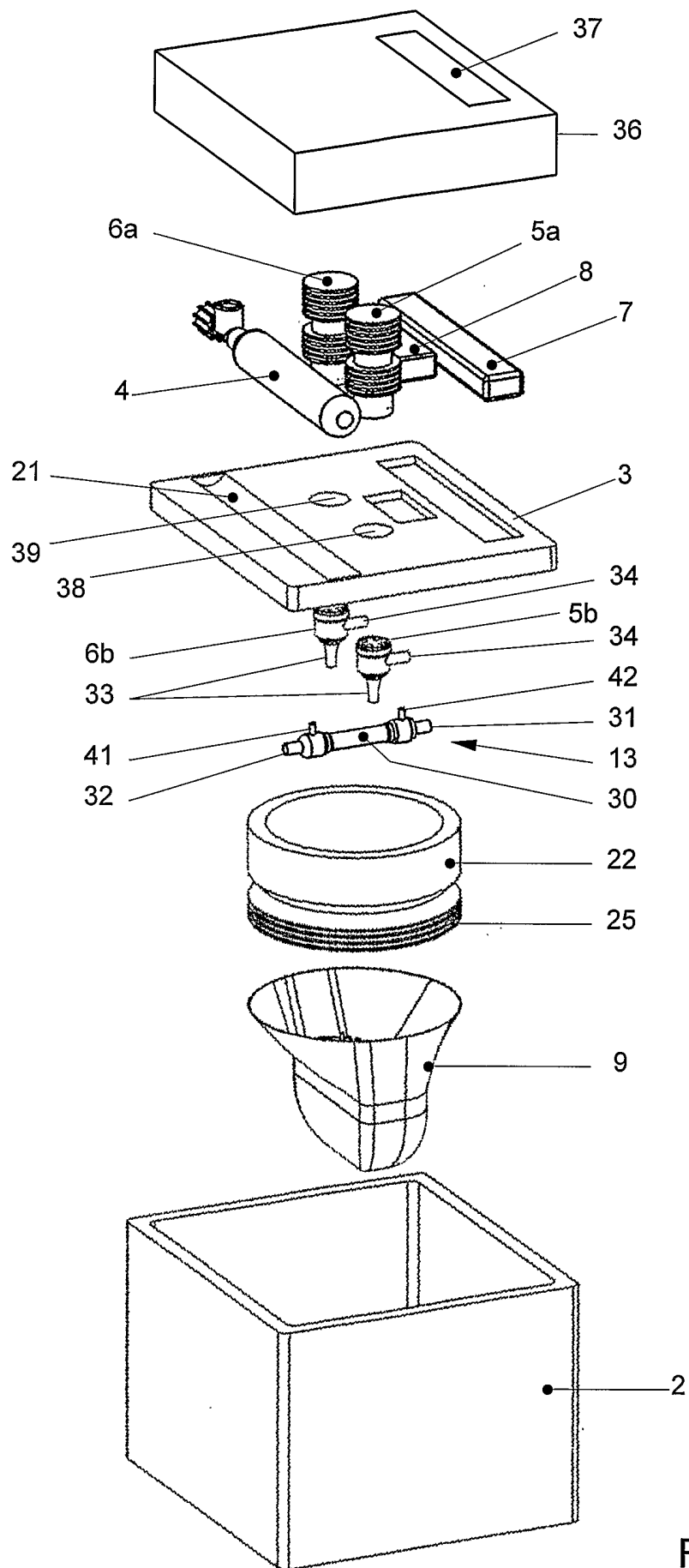

Fig. 7

## INTERNATIONAL SEARCH REPORT

International Application No  
PCT/NL2004/000539

A. CLASSIFICATION OF SUBJECT MATTER  
IPC 7 A01N1/02

According to International Patent Classification (IPC) or to both national classification and IPC

## B. FIELDS SEARCHED

Minimum documentation searched (classification system followed by classification symbols)  
IPC 7 A01N

Documentation searched other than minimum documentation to the extent that such documents are included in the fields searched

Electronic data base consulted during the international search (name of data base and, where practical, search terms used)

EPO-Internal, WPI Data

## C. DOCUMENTS CONSIDERED TO BE RELEVANT

Category °	Citation of document, with indication, where appropriate, of the relevant passages	Relevant to claim No.
A	WO 03/024214 A (ORGAN TRANSP SYSTEMS INC) 27 March 2003 (2003-03-27) page 1 - page 3, line 5 page 7, line 19 - page 10, line 24; figures	1-9
A	US 5 285 657 A (BACCHI BERNARD ET AL) 15 February 1994 (1994-02-15) column 1 - column 3, line 10 column 6, line 3 - column 7, line 2 column 8, line 18 - line 28; claim 1; figures 1,2	1-9
A	US 4 242 883 A (TOLEDO-PEREYRA LUIS H) 6 January 1981 (1981-01-06) the whole document	1-9
	----- -/--	

Further documents are listed in the continuation of box C.

Patent family members are listed in annex.

° Special categories of cited documents :

- \*A\* document defining the general state of the art which is not considered to be of particular relevance
- \*E\* earlier document but published on or after the international filing date
- \*L\* document which may throw doubts on priority claim(s) or which is cited to establish the publication date of another citation or other special reason (as specified)
- \*O\* document referring to an oral disclosure, use, exhibition or other means
- \*P\* document published prior to the international filing date but later than the priority date claimed

- \*T\* later document published after the international filing date or priority date and not in conflict with the application but cited to understand the principle or theory underlying the invention
- \*X\* document of particular relevance; the claimed invention cannot be considered novel or cannot be considered to involve an inventive step when the document is taken alone
- \*Y\* document of particular relevance; the claimed invention cannot be considered to involve an inventive step when the document is combined with one or more other such documents, such combination being obvious to a person skilled in the art.
- \* & \* document member of the same patent family

Date of the actual completion of the international search

18 November 2004

Date of mailing of the international search report

03/12/2004

Name and mailing address of the ISA

European Patent Office, P.B. 5818 Patentlaan 2  
NL - 2280 HV Rijswijk  
Tel. (+31-70) 340-2040, Tx. 31 651 epo nl,  
Fax: (+31-70) 340-3016

Authorized officer

Mue11ners, W

## INTERNATIONAL SEARCH REPORT

International Application No  
PCT/NL2004/000539

C.(Continuation) DOCUMENTS CONSIDERED TO BE RELEVANT		
Category °	Citation of document, with indication, where appropriate, of the relevant passages	Relevant to claim No.
A	WO 01/33959 A (UNIV AMSTERDAM ; DOORSCHOT BENEDICT MARIE (NL); JASPERS JORIS EMANUEL) 17 May 2001 (2001-05-17) cited in the application page 1 - page 4, line 24; figure 1 -----	1-9
A	WO 99/15011 A (HASSANEIN WALEED H) 1 April 1999 (1999-04-01) page 5, line 25 - page 6, line 22 page 23, line 3 - page 24, line 15; figure 4	1-9
A	& US 6 046 046 A (HASSANEIN WALEED H) 4 April 2000 (2000-04-04) cited in the application	
A	& US 6 100 082 A (HASSANEIN WALEED H) 8 August 2000 (2000-08-08) cited in the application -----	

## INTERNATIONAL SEARCH REPORT

Information on patent family members

International Application No

PCT/NL2004/000539

Patent document cited in search report		Publication date	Patent family member(s)	Publication date
WO 03024214	A	27-03-2003	US 2003054540 A1	20-03-2003
			EP 1435777 A1	14-07-2004
			WO 03024214 A1	27-03-2003
			US 2004082057 A1	29-04-2004
US 5285657	A	15-02-1994	FR 2667297 A1	03-04-1992
			AT 126010 T	15-08-1995
			AU 640268 B2	19-08-1993
			AU 8465191 A	18-06-1992
			CA 2052439 A1	29-03-1992
			DE 69111961 D1	14-09-1995
			DE 69111961 T2	23-11-1995
			DK 479635 T3	11-12-1995
			EP 0479635 A1	08-04-1992
			ES 2076489 T3	01-11-1995
			FI 914528 A	29-03-1992
			GR 3017626 T3	31-01-1996
			JP 2607994 B2	07-05-1997
			JP 6080503 A	22-03-1994
			NO 913771 A	30-03-1992
			NZ 239961 A	27-09-1993
			PT 99069 A ,B	29-10-1993
			US 5476763 A	19-12-1995
			ZA 9107746 A	29-03-1993
			US 4242883	A
WO 0133959	A	17-05-2001	NL 1013524 C2	09-05-2001
			AU 1741301 A	06-06-2001
			CA 2390248 A1	17-05-2001
			EP 1229788 A2	14-08-2002
			JP 2004500345 T	08-01-2004
			WO 0133959 A2	17-05-2001
WO 9915011	A	01-04-1999	US 6100082 A	08-08-2000
			US 6046046 A	04-04-2000
			AT 253819 T	15-11-2003
			AU 728233 B2	04-01-2001
			AU 9504298 A	12-04-1999
			CA 2304598 A1	01-04-1999
			DE 69819759 D1	18-12-2003
			DE 69819759 T2	23-09-2004
			DK 1017274 T3	22-03-2004
			EP 1017274 A1	12-07-2000
			ES 2210825 T3	01-07-2004
			JP 2001516768 T	02-10-2001
			PT 1017274 T	30-04-2004
			WO 9915011 A1	01-04-1999
US 6046046	A	04-04-2000	US 6100082 A	08-08-2000
			AT 253819 T	15-11-2003
			AU 728233 B2	04-01-2001
			AU 9504298 A	12-04-1999
			CA 2304598 A1	01-04-1999
			DE 69819759 D1	18-12-2003
			DE 69819759 T2	23-09-2004
			DK 1017274 T3	22-03-2004
			EP 1017274 A1	12-07-2000

## INTERNATIONAL SEARCH REPORT

Information on patent family members

International Application No

PCT/NL2004/000539

Patent document cited in search report		Publication date	Patent family member(s)	Publication date
US 6046046	A		ES 2210825 T3	01-07-2004
			JP 2001516768 T	02-10-2001
			PT 1017274 T	30-04-2004
			WO 9915011 A1	01-04-1999
US 6100082	A	08-08-2000	AT 253819 T	15-11-2003
			AU 728233 B2	04-01-2001
			AU 9504298 A	12-04-1999
			CA 2304598 A1	01-04-1999
			DE 69819759 D1	18-12-2003
			DE 69819759 T2	23-09-2004
			DK 1017274 T3	22-03-2004
			EP 1017274 A1	12-07-2000
			ES 2210825 T3	01-07-2004
			JP 2001516768 T	02-10-2001
			PT 1017274 T	30-04-2004
			US 6046046 A	04-04-2000
			WO 9915011 A1	01-04-1999