

(19) World Intellectual Property Organization
International Bureau



(43) International Publication Date
23 November 2006 (23.11.2006)

PCT

(10) International Publication Number
WO 2006/123333 A2

- (51) International Patent Classification:
A47K 3/024 (2006.01) A47K 3/022 (2006.01)
- (21) International Application Number:
PCT/IL2006/000575
- (22) International Filing Date: 16 May 2006 (16.05.2006)
- (25) Filing Language: English
- (26) Publication Language: English
- (30) Priority Data:
11/130,129 17 May 2005 (17.05.2005) US
11/130,130 17 May 2005 (17.05.2005) US
60/715,147 9 September 2005 (09.09.2005) US
60/715,177 9 September 2005 (09.09.2005) US
60/738,592 22 November 2005 (22.11.2005) US
- (71) Applicants and
(72) Inventors: PAZ, Ohad [IL/IL]; Ofir 12, 69014 Tel Aviv (IL). PAREZKY, Ofer [IL/IL]; Hadvoranit 2, 74205 Ness-ziona (IL).
- (74) Agent: ACTIVE KNOWLEDGE LTD.; P.O.B. 294, 36010 Kiryat Tivon (IL).
- (81) Designated States (unless otherwise indicated, for every kind of national protection available): AE, AG, AL, AM,

AT, AU, AZ, BA, BB, BG, BR, BW, BY, BZ, CA, CH, CN, CO, CR, CU, CZ, DE, DK, DM, DZ, EC, EE, EG, ES, FI, GB, GD, GE, GH, GM, HR, HU, ID, IL, IN, IS, JP, KE, KG, KM, KN, KP, KR, KZ, LC, LK, LR, LS, LT, LU, LV, LY, MA, MD, MG, MK, MN, MW, MX, MZ, NA, NG, NI, NO, NZ, OM, PG, PH, PL, PT, RO, RU, SC, SD, SE, SG, SK, SL, SM, SY, TJ, TM, TN, TR, TT, TZ, UA, UG, US, UZ, VC, VN, YU, ZA, ZM, ZW.

(84) Designated States (unless otherwise indicated, for every kind of regional protection available): ARIPO (BW, GH, GM, KE, LS, MW, MZ, NA, SD, SL, SZ, TZ, UG, ZM, ZW), Eurasian (AM, AZ, BY, KG, KZ, MD, RU, TJ, TM), European (AT, BE, BG, CH, CY, CZ, DE, DK, EE, ES, FI, FR, GB, GR, HU, IE, IS, IT, LT, LU, LV, MC, NL, PL, PT, RO, SE, SI, SK, TR), OAPI (BF, BJ, CF, CG, CI, CM, GA, GN, GQ, GW, ML, MR, NE, SN, TD, TG).

Declarations under Rule 4.17:

- as to the applicant's entitlement to claim the priority of the earlier application (Rule 4.17(iii))
- of inventorship (Rule 4.17(iv))

Published:

- without international search report and to be republished upon receipt of that report

[Continued on next page]

(54) Title: MULTI-POSITION SUPPORT APPARATUS FEATURING A MOTORIZED FOOT SUPPORT

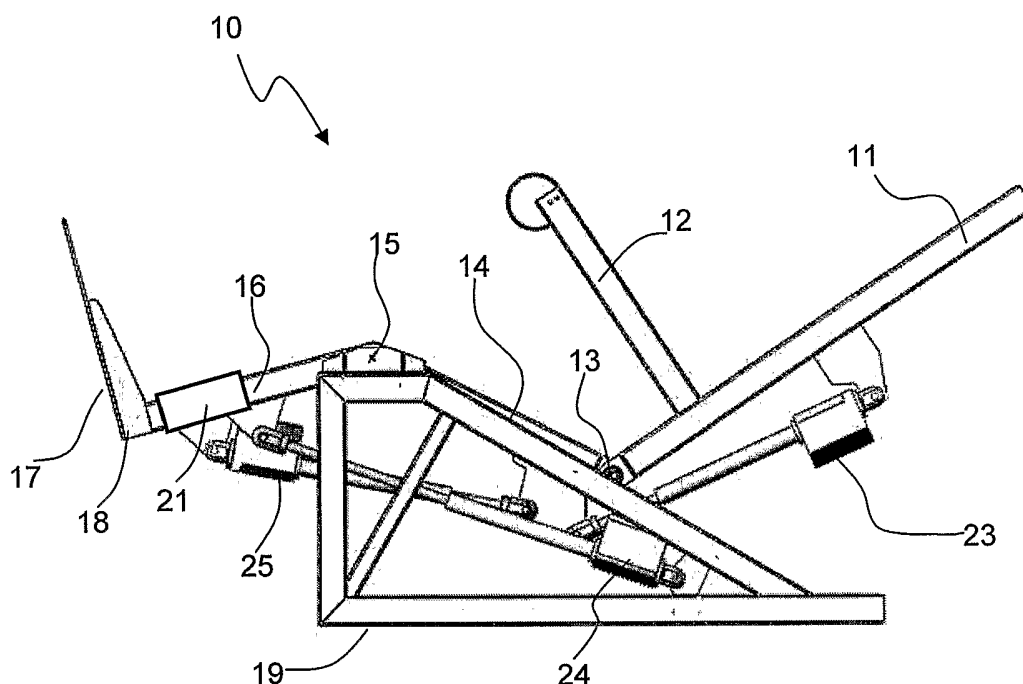

(57) Abstract: A bed featuring a motorized foot support. When the user wishes to stand up from lying down or sitting, the motorized foot support moves toward the head of the bed until it reaches the user's feet. When the user is brought into standing position, motorized foot support starts to come down so that the feet of the user are in close proximity to ground level.

WO 2006/123333 A2



For two-letter codes and other abbreviations, refer to the "Guidance Notes on Codes and Abbreviations" appearing at the beginning of each regular issue of the PCT Gazette.

MULTI-POSITION SUPPORT APPARATUS FEATURING A MOTORIZED FOOT SUPPORT

RELATED APPLICATIONS

5 This application claims priority to US patent application number 11/130129, titled: Massage And Bathing Chair, filed on May 17, 2005, and US Patent Application number 11/130130, titled: Patient Support Apparatus, filed on May 17, 2005, and US Provisional Patent Application number 60/715147, titled: Bathing system and corresponding method, filed on September 9, 2005, and US Provisional Patent Application number 60/715177,
10 titled: Multi-position support apparatus featuring a motorized foot support, filed on September 9, 2005, and US Provisional Patent Application number 60/738592, titled: Bathing system featuring springs elements surface, filed on November 22, 2005, which are incorporated by reference herein in their entirety.

FIELD AND BACKGROUND OF THE INVENTION

15 The present invention relates to supporting apparatus and, more particularly, to multi-position support apparatus featuring a motorized foot support.

Hereinafter, the term "engine" refers to any device that is able to move things, including, but not limited to motor, and actuator.

20 Basic principles and details relating to multi-position support apparatus featuring a motorized foot support needed for properly understanding the present invention are provided herein. Complete theoretical descriptions, details, explanations, examples, and applications of these and related subjects and phenomena are readily available in standard references in the fields of physics, electronics, home care devices, and elderly care.

25 There is prior art regarding elements, systems, and methods based on, or including, multi-position wheelchairs and multi-position beds. However, none of the following indicated prior art refers to multi-position support apparatus featuring the important and novel feature of motorized foot support.

U.S. Patent No. 5638563, issued to Iura Tadashi, discloses a posture change-over device, designed so that the posture of the head supporting frame when the back supporting frame is raised and pivoted can be selected from two postures; a posture where the head supporting frame is kept horizontal and a posture where the head supporting frame and the back supporting frame form one plane. Therefore, in the latter case, the bed can be used in the same manner as previous beds capable of raising the upper body, and in the former case, a user can raise his/her upper body without dropping the pillow or articles even when he/she raises his/her back. However, this device is unable to achieve a standing position and there is no user customization and no preprogrammed operation programs.

European Patent No. 1180352A1, issued to Soejima Noboru et al., discloses an apparatus for moving a body, wherein a phantom axis passing from the head through the center of the legs of the body is defined as a vertical axis, a phantom axis passing through the abdomen in the longitudinal direction is defined as a longitudinal axis, and a phantom axis passing through the abdomen in the lateral direction is defined as a lateral axis, and motions around these three axes are carried out individually or in combination in order to support, twist and vertically move a body suitably for various individual somatotype and posture. However, it is unable to achieve a standing position and there is no user customization and no preprogrammed operation programs.

European Patent No. 1413281A1, issued to Horitani Masao et al., discloses a bed wherein coordinates defined by a back angle and a knee angle, a pattern that connects between a coordinate point at which each of a back bottom and a knee bottom is horizontal and a coordinate point which is a final reaching point for a back lift-up operation and at which the back bottom is lifted up by multiple points is set, and a control section moves the back bottom and the knee bottom. However, it is unable to achieve a standing position. There is also no user customization and no preprogrammed operation programs.

U.S. Patent No. 6912746, issued to Grove Christopher John, discloses a bed for accommodating heavy persons. The bed is particularly for use in hospitals, where heavy patients have to be treated. The invention provides a bed comprising a frame; a central support section mounted on the frame; two opposite end support sections, one being a head section and the other being a foot section, each mounted for pivoting movement relative to the central section; and drive means for driving the end support sections for pivoting

movement relative to the central section; wherein the foot section has a platform which extends at an angle to the plane of the section, and the foot section can pivot to a position where the platform is substantially at ground level. In one embodiment the central section is mounted for pivoting movement about a pivot axis at or near to its edge adjacent the foot section, and further comprises drive means for driving the central support section for pivoting movement about said pivot axis. However, it is unable to achieve a standing position and there is no user customization and no preprogrammed operation programs.

U.S. Patent No. 4685159, discloses Oetiker, Hans, discloses a hospital bed which includes a bed frame consisting of a center bed frame section and of a head bed frame section and foot bed frame section pivotal relative to the center bed frame section; the bed frame is supported relative to a chassis by way of a first intermediate yoke-like frame structure providing pivotal movement in either direction of the bed frame about a single transverse axis; the first intermediate frame structure is pivotally connected with a second intermediate frame structure to provide tilting about a longitudinal axis; the second intermediate frame structure which consists of a parallelogram-linkage system provides for height adjustments of the bed frame and is so constructed and arranged as to permit the bed frame to assume a nearly vertical position with the foot bed frame section at the bottom without interference from the transverse bearer member of the chassis. However, there is no description or suggestion for a motorized foot support and there is no user customization and no preprogrammed operation programs.

U.S. Patent No. 5023967, issued to Ferrand, Robert, discloses a system providing universal support for patients, and includes an articulated platform supported by a universal joint supported by a pair of hydraulic support arms, and by a pair of lesser hydraulic arms spaced from the universal joint. The platform is comprised of multiple relatively hinged panels which are also hydraulically driven. Thus, the platform is capable of assuming a large number of configurations, including full sitting and standing positions. A patient cushion system includes multiple cushions which are individually or severally controlled through a valve and manifold system which is computer controlled for cycling cushion pressures between high and low pressures. The sides of the bed platform have restraining members which may be lowered and hinged in toward the patient to provide access to the patient. These restraining members also provide for supplemental support of such things as a canopy

or tension weight. Further, a pendulum arm is attachable to the side restraint member for supporting auxiliary equipment in an upright position regardless of the orientation of the bed. A sanitary system is incorporated in the cushion system to provide cleansing and removal of bodily wastes. A restraint system, also operable by the cushion system, may be provided over the top of the patient to further restrain a patient. However, there is no description or suggestion for a motorized foot support and the disclosed embodiment is highly complicated and therefore expensive.

U.S. Patent No. 3997926, issued to England, Robert W., discloses a bed including an open supportive framework pivotably mounting an occupant support platform for movement between a horizontal and an upright position. The bed includes a drive mechanism and associated motor with controls to enable selective movement of the platform between the two positions. The drive assembly includes a lead screw operatively connecting the open framework to the platform. A nut pivotably mounted on the framework threadably receives the screw which, when turned, causes pivotal movement of the platform between the two positions. The framework is open at a foot end of the bed to enable an occupant to move freely toward or away from the support platform. The platform includes a foot rest assembly that may be selectively moved longitudinally relative to the platform between an operative and inoperative position. In the operative position, the foot rest may be utilized to receive and support the weight of the occupant, assuring that the platform cannot be pivoted past either position, that the platform cannot fall during a power outage, and that the motor will not operate unless the foot rest is in the operative position. However, this bed is unable to achieve a sitting position. Also, there is no description or suggestion for a motorized foot support and there is no user customization and no preprogrammed operation programs.

U.S. Patent No. 6862762, issued to Johnson, Michael Karl, discloses the patient support apparatus which includes a base frame and a patient support assembly. The patient support assembly is pivotably mounted the base frame and is moved by a first actuator to rotate between a horizontal position and an upright position. The patient support assembly includes an upper body portion, a lower body portion and a leg portion. The upper body portion, the lower body portion and the leg portion are pivotably interconnected with a linkage frame so that they can be moved in unison by a second actuator between a supine

configuration and an upright, chair shaped configuration. Thus, the patient support apparatus is adjustable between a flat, bed-shaped configuration and a seat-shaped configuration, and is also movable between a horizontal position and an upright position. However, there is no description or suggestion for a motorized foot support.

5 U.S. Patent No. 6101646, issued to Son, Chong Eun, discloses a dual-function bed used as a chair, equipped with a patient toilet. The bed is designed to be selectively used as a chair by controlling the folding angle of it with the operation of a reduction motor. Moreover, as attached equipment, the toilet has the capabilities of cleaning itself and discharging excrement. Subsequently, this invention allows a disabled and non-ambulatory
10 patient to relieve oneself and rest by simply operating a control unit without nurse. However, it is unable to achieve a standing position and there is no alternative method for waste disposal via an appropriate sewage system. Also, there is no user customization and no preprogrammed operation programs.

U.S. Patent Application No. 20040210155A1, issued to Takemura Yasuhiro et al.,
15 describes a monitoring device which can detect conditions of a sleeping person. A monitoring device comprising: multiple independent distance sensors installed facing different positions in a monitored target area to be monitored for measuring a distance to a monitored target, a calculating unit for calculating changes over time in the outputs of the distance sensors, and a detection processor for detecting changes in shape of the monitored
20 target based on the calculated changes over time in one or multiple distance sensor among the multiple distance sensors. However, there is no description or suggestion for operating an angular position change and there is no user customization and no preprogrammed operation programs.

U.S. Patent Application No. 20040004559A1, issued to Rast Rodger H, describes a
25 system allowing persons to operate their computer comfortably while lying in bed. The system has a keyboard that provides pre-selection feedback indicating prior to a keystroke being entered, thus allowing the individual to verify the correct key before pressing down the key. Additional aspects of the system include the user of display goggles with panning control, and a see-through mode. In addition, there is a keyboard having multiple keys that
30 upon being pressed past a selection threshold generate a keystroke for entry into the current application, wherein the improvement comprises: means of sensing intermediate key

pressure which is less than that required to generate a selection; and programming in the application for generating feedback as to which key is subject to the intermediate pressure, wherein the user can change hand positioning to find the desired key before entering a keystroke. However, there is no description or suggestion for operating a multi-position support apparatus

5 U.S. Patent No. 6131868, issued to Welling, Jeffrey R describes a communication and control device for attachment to the head end of a hospital bed for positioning a voice activated communication and control module adjacent a patient's head. The device comprises an arm having first, second and third arm segments, with first and second articulating joints connecting the first and second and second and third arm segments respectively. A securing mechanism releasably secures the first arm segment to the bed, and a third articulating joint connects the first arm segment to the securing mechanism. The first articulating joint accommodates electrical transmission wire substantially within the joint. However, there is no description or suggestion for controlling a motorized foot support.

10 U.S. Patent No. 6781517, issued to Moster, Jeffrey A., discloses a communication and control apparatus which includes a control unit having a surface accessible to a person on a bed, the control unit being coupled to a portion of the bed. However, the control unit does not move the bed from a standing position to a lying position through a sitting position and there is no description or suggestion for operating a motorized foot support.

15 It is important to note that all of the aforementioned patents do not disclosed or even mentioned the novel motorized foot support of the present invention and the novel armrest which are unique to the present invention.

To date, the inventor is unaware of prior art teaching of a multi-position support apparatus featuring a motorized foot support.

25 There is thus a need for, and it would be highly advantageous to have a multi-position support apparatus featuring a motorized foot support.

Moreover, there is a need for such a multi-position support apparatus which is significantly safer, automatic, and therefore, more cost effective, than currently available multi-position support apparatuses.

30

SUMMARY OF THE INVENTION

The present invention relates to supporting apparatus and, more particularly, to multi-position support apparatus featuring a motorized foot support.

Thus, according to the present invention, there is provided a multi-position support
5 apparatus able to change its angular position featuring: a back support, a seat, at least one leg support, at least one motorized foot support, whereby, the at least one motorized foot support moves toward the head of the multi-position support apparatus until it reaches a user's feet when the user wishes to stand up from lying down or reclining or sitting.

According to further features in preferred embodiments of the present invention, the
10 multi-position support apparatus further includes at least one motorized foot support featuring a sensor.

According to still further features, the sensor is a pressure sensor, whereby the pressure sensor measures the intensity of the resistance from the user's legs.

According to still further features, the multi-position support apparatus is covered by
15 a mattress.

According to still further features, at least one motorized foot support is connected to an operating engine through slots in the mattress.

According to still further features, at least one motorized foot support is connected to an operating engine using at least one arm-like extension.

According to still further features, multi-position support apparatus further featuring:
20 a multi-position support apparatus base, at least one hand support, an integrated toilet.

According to still further features, the multi-position support apparatus featuring: at least one engine to change the multi-position support apparatus angular position, at least one control system, whereby the at least one control system is controlling the at least one
25 engine and the at least one motorized foot support, whereby the at least one control system prevents the user from getting to an angular position from which the user is able to fall forward from the multi-position support apparatus.

According to still further features, the user controls the multi-position support apparatus by using controlling means.

According to still further features, there are at least two of the engine and the control
30 system allows the user to operate each engine of the at least two engines separately.

According to still further features, the at least one motorized foot support featuring a sensor placed about the at least one motorized foot support, whereby the sensor detects objects and prevents the at least one motorized foot support from crushing them.

5 According to still further features, the back support featuring a sensor placed about the back support, whereby the sensor detects objects and prevents the back support from crushing them.

According to still further features, the multi-position support apparatus is a parallelogram-based multi-position support apparatus.

10 According to still further features, the length of the multi-position support apparatus is adjusted to the height of the user.

According to still further features, at least one part of the multi-position support apparatus is a floating part, whereby the at least one floating part enables the multi-position support apparatus to move according to the motion of the user .

15 According to still further features, multi-position support apparatus further featuring at least one device for entering an emergency response operation.

According to still further features, multi-position support apparatus further featuring operational customized parameters setting and saving means.

20 According to still further features, the at least one multi-position support apparatus is adjustable between laying, reclining, and standing positions, whereby the at least one multi-position support apparatus is generally vertical in the standing position.

According to still further features, the at least one multi-position support apparatus is adjustable between reclining and standing positions.

According to still further features, the at least one multi-position support apparatus is adjustable between sitting and standing positions.

25 According to still further features, the multi-position support apparatus further featuring wheels, whereby the wheels enable the multi-position support apparatus to move.

According to still further features, the multi-position support apparatus further featuring foldable tray attached to the multi-position support apparatus.

30 According to another aspect of the present invention, there is provided a multi-position support apparatus able to change its angular position featuring: a motorized foot support, a muscle tonus monitoring device, whereby, the motorized foot support is able to

move towards the head of the multi-position support apparatus and to move in an perpendicular direction.

According to further features, the multi-position support apparatus further featuring motorized protective barriers.

5 According to still further features, the at least one motorized foot support featuring a pressure sensor, whereby the pressure sensor measures the intensity of the resistance from the user's legs.

According to still further features, the multi-position support apparatus is covered by a mattress.

10 According to still further features, the at least one motorized foot support is connected to an operating engine through slots in the mattress.

According to still further features, the at least one motorized foot support is connected to an operating engine using at least one arm-like extension.

15 According to another aspect of the present invention, there is provided a method featuring: providing a multi-position support apparatus accepting a user in a standing position, moving the user into a predefined reclining position, providing a motorized foot support, moving the motorized foot support towards the head of the multi-position support apparatus until it is reaching the user's feet, returning the user to a standing position, moving the motorized foot support towards the floor.

20 According to further features, the reclining position is a laying position.

According to still further features, the moving the user into a predefined reclining position featuring leaning the user backwards, and upon achieving a predefined intermediate reclined angle, moving the user into the predefined reclining position; and the returning the user to a standing position featuring moving the user into a predefined intermediate inclined
25 angle, and upon achieving the predefined reclining position moving the user into the standing position.

According to still further features, the returning the user to the standing position featuring detecting objects and preventing the multi-position support apparatus from crushing them.

According to still further features, the moving the user into the predefined reclining position featuring detecting objects and preventing the multi-position support apparatus from crushing them.

5 According to still further features, the reaching the user's feet featuring measuring a minimum predefined intensity of resistance from the user's legs.

According to another aspect of the present invention, there is provided a method featuring: providing a multi-position support apparatus accepting a user in a standing position, moving the user into a predefined reclining position, providing a motorized foot support, returning the user to a standing position, recognizing muscle tonus decrease,
10 preventing falling.

According to further features, the preventing falling further featuring bringing the user back to a safe reclining position.

According to still further features, the preventing the falling further featuring
upbringing motorized protective barriers.

15 According to still further features, the preventing the falling featuring pushing the user's feet forward.

According to still further features, the preventing the falling featuring pushing the user's knees forward.

The present invention for multi-position support apparatus featuring a motorized foot
20 support successfully address limitations of presently available multi-position beds. The device of the present invention is readily implemented using standard hardware components and standard software modules. Moreover, the system of the present invention is generally applicable as a 'stand-alone' multi-position support apparatus featuring a motorized foot support system, or as a multi-position support apparatus featuring a motorized foot support
25 used in combination with other methods, devices, and systems, performing various operations.

Implementation of the multi-position support apparatus of the present invention involves performing or completing selected tasks or steps manually, semi-automatically, fully automatically, and/or a combination thereof. Moreover, depending upon actual
30 instrumentation and/or equipment used for implementing a particular preferred embodiment of the disclosed system and corresponding method, several embodiments of the present

invention could be achieved by hardware, by software on any operating system of any firmware, or a combination thereof. In particular, as hardware, embodiments of the invention could exist by variations in the physical structure. Additionally, or alternatively, as software, selected functions of the invention could be performed by a data processor, such as a computing platform, executing a of computer program types of software instructions or protocols using any suitable computer operating system.

BRIEF DESCRIPTION OF THE DRAWINGS

The present invention is herein described, by way of example only, with reference to the accompanying drawings. With specific reference now to the drawings, it is stressed that the particulars shown are by way of example and for purposes of illustrative discussion of the preferred embodiments of the present invention only, and are presented in order to providing what is believed to be the most useful and readily understood description of the principles and conceptual aspects of the present invention. In this regard, no attempt is made to show structural details of the present invention in more detail than is necessary for a fundamental understanding of the invention, the description taken with the drawings making apparent to those skilled in the art how the several forms of the invention may be embodied in practice. Identical structures, elements or parts which appear in more than one figure are preferably labeled with a same or similar number in all the figures in which they appear. In the drawings:

FIG. 1 is a schematic illustration of multi-position support apparatus in accordance with the present invention; and

FIG. 2 is a schematic illustration of motorized foot support in accordance with the present invention; and

FIG. 3 is another schematic illustration of multi-position support apparatus featuring a motorized foot support in accordance with the present invention; and

FIG. 4 is another schematic illustration of multi-position support apparatus featuring a motorized foot support in accordance with the present invention; and

FIG. 5 is a schematic illustration of floating back support in accordance with the present invention; and

FIG. 6 is a schematic illustration of an arm rest in accordance with the present invention; and

FIG. 7 is a schematic illustration of exemplary preferred angles in accordance with the present invention; and

5 FIG. 8 is another schematic illustration of multi-position support apparatus featuring one engine in accordance with the present invention; and

FIG. 9 is a schematic illustration of multi-position support apparatus featuring two engines in accordance with the present invention; and

10 **DESCRIPTION OF THE PREFERRED EMBODIMENTS**

The present invention relates to supporting apparatus and, more particularly, to multi-position support apparatus featuring a motorized foot support.

The preferred embodiments of the device of the present invention are discussed in detail below. It is to be understood that the present invention is not limited in its application
15 by the details of the order or sequence of steps of operation or implementation of the method and/or the details of construction, arrangement, and composition of the components of the device set forth in the following description, drawings or examples. While specific steps, configurations and arrangements are discussed, it is to be understood that this is done for illustrative purposes only. A person skilled in the relevant art will recognize that other
20 steps, embodiments, configurations and arrangements can be used without departing from the spirit and scope of the present invention.

The present invention is capable of other embodiments or of being practiced or carried out in various ways. Also, it is to be understood that the phraseology, terminology and notation employed herein are for the purpose of description and should not be regarded
25 as limiting.

Elderly people have difficulty bending over and moving from a standing position to a sitting position, and vice versa.

People with severe knee problems also have difficulty bending their knees. As a result, the action of sitting down on a bed is difficult for them.

Overweight and/or obese people sometimes find it difficult to bend their knees when sitting down on a bed, and have difficulty rising up from a bed.

For simplicity, hereinbelow the terms "bed" and "multi-position bed" and "multi-position support apparatus" should have the same meaning without limiting the scope of the present invention.

The multi-position support apparatus featuring a motorized foot support of the present invention receives and lowers the user from a standing position (while both the bed and user are about vertical), into a reclining or horizontal position, optionally without having to tie and/or secure the user to the bed before the angular position change occurs. Then, when the user wants to get out of bed, the bed raises the user from lying down to standing up.

In an exemplary embodiment option of the present invention, the multi-position support apparatus features wheels which enable it to move. In an alternative exemplary embodiment option of the present invention, the wheels which enable the bed to move are motorize. In the case where the wheels which enable the bed to move are motorize, it is possible to control the movement of the bed using a control panel. The control panel allows the user to operate the different engines separately, and/or to perform complete operations such as transition from a standing position to a sitting position and vice versa, transition from a standing position to a lying position and vice versa, and transition from a sitting position to a lying position and vice versa.

Referring to FIG. 1, and FIG. 2, a main novel feature of the present invention is motorized foot support 17. It is important to have motorized foot support 17 to prevent the user from sliding as the bed shifts from a lying position to a standing position and/or when the bed shifts from a sitting position to a standing position. When the user wishes to stand up from lying down or sitting, motorized foot support 17 moves toward the head of the bed until it reaches the user's feet. Optionally, motorized foot support 17 is actuated by motor 21.

Detecting when the foot support has reached the feet of the user lying in the bed can be achieved in various novel ways. For example, a pressure sensor that measures the intensity of the resistance from the user's legs can be used. The minimal threshold of intensity measured by the sensor should be set to a high enough value to ensure that

motorized foot support 17 has actually reached the user's feet, and not another object that possibly is on the bed. For example, as a safety precaution, it is important to make sure that the user is not brought to a standing position while stepping on a blanket or a pillow.

5 However, if the user purposely wants to be brought to a standing position while stepping on a blanket or a pillow, the pressure sensor should be configured and set to ensure that a minimal predefined amount of pressure is applied, implying that the object is pressed to the user's feet. Only when the appropriate amount of pressure is measured by the sensor, the bed begins to rise to a standing position.

10 In an exemplary embodiment option of the present invention, when the user wishes to shift from a lying position to a sitting position, it is possible to waive the movement of foot support. Alternatively, it is possible to enable the bed of the present invention to begin moving when the amount of pressure measured by the sensor is smaller than the predefined amount of pressure required for beginning the shifting, from a lying position to a standing position.

15 In an exemplary embodiment option of the present invention, when the user wishes to be brought to a standing position, the multi-position support apparatus starts to change its angular position simultaneously while foot support moves toward the direction of the head of the multi-position support apparatus. Performing these two actions simultaneously saves time and does not endanger the user, as long as motorized foot support 17 reaches the
20 user's feet in a reasonable amount of time in relation to the angular position of the multi-position support apparatus.

When the multi-position support apparatus reaches a predefined angle, motorized foot support 17 starts to come down so that the feet of the user are in close proximity to ground level when the user is brought into standing position. The object of this operation is to
25 prevent the user from having to descend a step.

The engine of motorized foot support 17 can be positioned either underneath the multi-position support apparatus or on the side of the multi-position support apparatus.

In an exemplary embodiment option of the present invention, motorized foot support 17 may be connected to its operating engine through slots in the mattress, as illustrated in
30 FIG. 2, FIG. 3, and FIG. 4. Alternatively, motorized foot support 17 may be connected to its operating engine using at least one arm-like extension reaching out from at least one side

of the multi-position support apparatus (not shown in the figures). In that alternative embodiment it is not required that the mattress be slotted.

Referring to FIG. 2, motorized foot support 17 can move along axis 300 or along axis 301.

5 The bed of the present invention can also be used as a chair. In an exemplary embodiment option of the present invention, the bed can be moved into a sitting position, like a TV recliner.

Referring to FIG. 3, an exemplary embodiment of the bed of the present invention
10 features at least the following:

(a) Foot support 17 able to move towards the head of the bed when the bed is in positions other than standing, and towards the ground when the bed is in standing position (i.e. about vertical) or moves towards a standing position.

(b) Multi-position support apparatus

15 (c) Optionally, the multi-position support apparatus being covered by a mattress. In another exemplary embodiment option the mattress comes equipped with the means for it to be attached to the bed of the present invention. Exemplary attachment means are nails, screws, hooks, and press-studs.

20 In an exemplary embodiment option of the present invention, the bed is equipped with a toilet bowl. Optionally, when the toilet bowl is being used, the bed shifts to a sitting position. Optionally, the toilet bowl usage is indicated by the user via a control panel (not shown in the figures).

25 In an exemplary embodiment option of the present invention, a foldable tray is attached to the multi-position support apparatus. The foldable tray may be used as a base for placing various objects such as food, drinks, dishes, books, a remote control, a telephone, a computer, an alarm clock, etc.

The foldable tray can be folded in any way known in the art. Optionally, when the
30 bed is changing its angular position, the foldable tray can be moved aside either manually by

the user, or by an engine powered by any means known in the art, to prevent objects placed on it from falling down as the multi-position support apparatus moves.

In another exemplary embodiment option of the present invention, the bed can be raised vertically (i.e. up and down). The ability to raise the bed vertically is useful and convenient for when a user is receiving ambulatory treatments, physical examinations,
5 getting therapy, massage, and/or any other treatments known in the art. By raising and lowering the bed, the bed's height can be adjusted to the height of the caregiver.

In another exemplary embodiment option of the present invention, the bed's armrests
10 are not fixed to any moving parts of the bed. Thus, the user can place a blanket or any other object on the armrests before the bed is shifted from one position to another, without the object falling from the arm rests. Optionally, the bed includes a special shelf and/or tray on which various objects can be placed so that they will not fall down when the bed shifts from one position to another.

15

Configurations, components, operation, and implementation of the multi-position support apparatus of the present invention, are better understood with reference to the following description and accompanying drawings.

Referring to FIG. 1, an exemplary embodiment of multi-position support apparatus
20 10, features at least the following: back support 11, back-seat angle 13, seat 14, seat-leg angle 15, leg support 16, motorized foot support 17, and multi-position support apparatus base 19. Moreover, multi-position support apparatus 10 optionally features at least one hand support 12 and leg-foot angle 18. In an exemplary embodiment of the present invention, there is back-seat angle 13, seat-leg angle 15, and leg-foot angle 18 featuring a
25 pivot, as know in the art. FIG. 3 illustrates another exemplary preferred embodiment of the present invention features back support 403, seat 402, seat-leg angle 401, and leg support featuring motorized foot support 17.

FIG. 4 illustrates an exemplary embodiment of the bed of the present invention in horizontal position with elements 504 and 506.

In the following description of the device of the present invention, included are only
30 main or principal details needed for sufficiently understanding proper 'enabling' utilization

and implementation of the disclosed device. Accordingly, descriptions of the various required or optional minor, intermediate, and/or, sub systems, which are readily known by one of ordinary skill in the art, which are available in the relevant prior art and technical literature.

5 Multi-position support apparatus 10 uses engines to change its angular position. For decorative or space-saving purposes, multi-position support apparatus 10 can be designed with all or most of the engines controlling its angular position concentrated beneath seat 14.

The electro-mechanical structure of multi-position support apparatus 10 of the present invention may be constructed in a variety of ways known in the art, and in the novel
10 constructions as described in the following exemplary embodiments.

The angles of multi-position support apparatus 10 are programmed so that the user returns to the standing position with maximum stability; slightly reclined. Because of its slightly reclined angle, multi-position support apparatus 10, when in a standing position,
15 does not throw the user off-balance. It is to be understood that the meaning of "reclining" may be interpreted as "backward inclining."

FIG. 7 illustrates the angles of multi-position support apparatus 10 in standing position. Either in a standing position or when entering a standing position, angle 41 is larger than 180 degrees, in order to prevent the user from falling. Angle 40 should be
20 smaller than 180 degrees, but not smaller than a predefined angle, which is dependent on the angular position of multi-position support apparatus 10 in its entirety.

The control system of the system of the present invention functions to prevent the user from manually reducing angle 40 beyond an angle wherein exists the possibility that the user will fall forward from the multi-position support apparatus.

25 By using the present invention, the probability of accident is very low. Receiving the user from a standing position - and returning the user to a standing position - minimizes the probability of bed-related accidents occurring.

It is to be understood that the present invention is useful for people who cannot stand. In that case, the present invention is receiving the user from a sitting position - and
30 returning the user to a sitting position.

Angular change that is too fast can cause dizziness in elderly people. This phenomenon is known in the art as orthostatic hypotension. Optionally, the speed at which multi-position support apparatus 10 changes its angular position can be controlled and adjusted for the comfort and health condition of a user. Optionally, when the angular position
5 changes, it is possible to stop the apparatus by using the control panel or any other controlling device

Moreover, during the transition from laying position to standing position, elderly people might suffer from orthostatic hypotension. As a result, elderly people may feel weakness, muscle tonus decrease, and even possibly faint. Muscle tonus decrease during
10 transition to standing position may result in falling of the user from the bed. During the transition from laying position to standing position, the user is leaned against the bed until the user is standing. The danger in losing muscle tonus is slipping down or to the side of the bed, and even falling to the front.

In an exemplary embodiment of the present invention, in order to recognize muscle tonus decrease and prevent the falling, the bed features a muscle tonus monitoring device.
15 Muscle tonus monitoring can be achieved by various devices known in the art.

When the muscle tonus monitoring device is detecting a critical reduction in user's muscle tonus, the bed is automatically bringing the user back to a safe reclining position. In an exemplary embodiment option of the present invention, the bed prevent the falling using
20 the following method.

Optionally, there is upbrining motorized protective barriers on the sides of the bed, thus preventing the user from slipping to the side.

There is motorized foot support 17 pushing the user's feet forward by moving on axis 301 as illustrated in FIG. 2. Thus, legs of the user are used as a lever and prevent the user
25 from falling forward. Moreover, the lever effect helps to lean the body of the user against the bed.

Optionally, there is pushing the user's knees forward, resulting in knees bending. Along with the feet, which are pushed forward, the user is brought to a safe position. It is important that the knees and feet are pushed forward, rather than the body of the bed is
30 brought backward. Thus, the bed fully supports the body of the user, keeping constant

contact with the user. Keeping constant contact with the user and no gap between the user's body and the bed, reduces the falling of the bed probability.

There is gradual returning of the bed to reclining position, constantly keeping contact with the body of the user.

5

FIG. 1 illustrates an exemplary embodiment option of multi-position support apparatus 10, capable of entering into positions of standing, sitting and reclining.

Engines are connected to the various parts of multi-position support apparatus 10. For example, engines are connected to back support 11, seat 14, and leg support 16. In
10 another optional embodiment (not shown in the figure), there are engines connected to the device's pivots. For example, the two engines can be connected to back-seat angle 13 and seat-legs angle 15.

The angle of back support 11, seat 14, and leg support 16, changes during operation in order to achieve maximum stability and put minimal pressure on the legs. In an
15 exemplary embodiment option, the user enters the apparatus in a standing position, leans backwards, and upon achieving a reclined angle of 20 to 60 degrees, the apparatus begins to move the user into a sitting position. When the apparatus moves from sitting to standing the user is first brought to an inclined position of between 20 and 60 degrees, and only then is brought to a full standing position.

20 An optional exemplary embodiment option of the present invention prevents a situation in which multi-position support apparatus 10 descends on the foot of an operator who is not the user, such as a nurse. One or more sensor is placed in or on foot support 17. The one or more sensor detects objects and prevents foot support 17 from crushing them. Optional sensors include, but are not limited to, infra-red sensor, electric footboard that
25 sends a signal when it is stepped upon, micro switch, camera, or any other sensor known in the art.

Another optional exemplary embodiment of the present invention prevents a situation in which back support 11 crushes an operator who is not the user, such as a nurse. One or more sensor is placed in or on back support 11. The one or more sensor detects objects and
30 prevents back support 11 from crushing them. Optional sensors include, but are not limited

to, infra-red sensor, electric footboard that sends a signal when it is stepped upon, micro switch, camera, or any other sensor known in the art.

In order to achieve a reclining position (180 degrees), it is possible to create an indentation in the pivot area so that the pivot will fall into the indentation when the multi-
5 position support apparatus is stretched, as required for a reclining position.

Optionally, the armrests of the multi-position support apparatus of the present invention can move up, down, and to the sides, to enhance the user's comfort. Optionally, the armrest can be detached from the multi-position support apparatus. In this case, when the multi-position support apparatus moves, the armrests are not moving along with it, to
10 allow the user to comfortably reach for an object or shelf during changes in position.

Referring to exemplary embodiment option illustrated in FIG. 8, the use of one engine and a parallelogram-based structure enables the multi-position support apparatus to shift from a standing to a sitting position, or from a sitting to a reclining position.

Parts 80 and 90 operate a rod that can decrease or increase in length. When the rod's
15 length grows, the device shifts to a reclining position.

Referring to optional embodiment illustrated in FIG. 9, the leg-support and back-support move nearly together and therefore one engine can be used for both. The second engine is used for changing the angle of the multi-position support apparatus.

FIG. 9 illustrates a parallelogram-based structure device with two engines. The
20 operation of the first engine is identical to that of the parallelogram-based structure device with one engine. Operation of the second engine raises and lowers the device. 101 is an engine for shifting from a sitting to a standing position.

The apparatus is fixed to axis 103.

The purpose of engine 102 is to shift the apparatus from a sitting to a lying position.

25 It is to be noted that in the parallelogram-based structure device, 104 and 105 are parallel and move in tandem. In a non-parallelogram-based structure device, it is sometimes possible to control each of the parts independently or almost independently.

Referring to FIG. 1, an optional exemplary embodiment of the present invention shows the states of engines 23, 24, and 25 setting the angular position of multi-position
30 support apparatus 10.

Use of three or more engines to control the angular position of multi-position support apparatus 10 enables further adjustment of the movement of multi-position support apparatus 10, for the comfort of the user.

It is to be understood that multi-position support apparatus 10 may include more than
5 three parts where each part may feature a separate engine.

In an optional exemplary embodiment of the present invention, multi-position support apparatus 10 features different lengths and therefore caters to users of various heights. Therefore, the length of multi-position support apparatus 10 should be adjusted to the
10 height of the user. Adjustment of multi-position support apparatus 10 to the user's height may be accomplished by controlling the lengths of leg-support 16 and back-support 11.

When multi-position support apparatus 10 shifts from the position of sitting to reclining, the user's body may slide down. This motion can cause uncomfortable friction to an unclothed body. To prevent the friction, it is possible to enable multi-position support
15 apparatus 10 to move according to the motion of a user. For example, enabling the back of the bed to move according to the motion of a user's back. Referring to FIG. 5, back support 62 is floating over back-support frame 60. In an optional exemplary embodiment of the present invention, the floating of back support 62 over back-support frame 60 is achieved by slides 61.

20 In an optional exemplary embodiment, one or more of the following parts may be floating parts: head support, back support, and leg support.

According to another option, the floating is achieved by using the following optional embodiments:

(a) Two or more tracks. Hereinafter, the term "track" refers to any device that
25 enables movement along a specific direction.

(b) A spring holding the floating part in place is an exemplary solution for ensuring that the floating part does not move independently. To prevent quick movement by the spring it is possible, for example, to integrate the spring with a piston.

(c) Using a telescopic device. An exemplary telescopic device is shock absorbers
30 such as those used in motorcycles or automobile luggage compartments (trunks). The

functionality of the telescope device is to ensure that the support is not moving by itself and/or not moving independently when the user momentarily gets up.

It is to be understood that the use of a telescopic device is just an example and floating parts can be implemented with any other device known in the art, such as, but not limited to, the prior art wheelchairs disclosed in the background of the invention section of the present invention. As long as no command is given to change the angular position of multi-position support apparatus 10 and/or as long as the engine is idle, the floating part's position on the slide is fixed. This can be achieved by using a pin, step motor, electro-magnet, etc. In this case, the telescopic device is not needed, as the floating part is not moving independently.

The floating device moves along at least one track. Options: a track down the middle, two tracks down the sides of the back-support, or any other equivalent implementation.

Optionally, instead of using a floating device, a device moved by an engine over a track can be used. This is made possible due to the fact that the distance the user's back should move depends on the angular position of the chair/apparatus, and therefore can be measured in advance.

The starting positions of the floating parts can be determined according to the specific user's height. In that case, the multi-position support apparatus of the present invention adjusts to different heights of users by moving the floating parts' positions according to the user's height. The taller a person is, the further apart the floating parts' starting position is in the apparatus' standing position.

Hereafter the floating parts of the exemplary multi-position support apparatus are described.

Referring to FIG. 1, parts 11 and 14 are nearest to one another in a standing position.

The following example describes the movement of the parts in order to prevent uncomfortable friction when the apparatus changes its angular position. When an active control system that controls the position and movement of the floating parts is used, parts 11 and 14 move closer together as the apparatus shifts from a sitting to a reclining position.

Another option is using floating parts without active control. The floating parts are placed on a slide. When the user sits, parts 11 and 14 move away from one another. When the user lies down, parts 11 and 14 move closer together. To sum up, when shifting from a

standing to a sitting position the parts should move away from each other, and when shifting from sitting to reclining the parts should move closer.

It is to be understood that the floating-parts solution as an exemplary method can be implemented on any of the users' body supporting parts, including the backseat and leg supports. Because relative movement is needed, it is sufficient that only the back-support
5 part and/or the leg-support part be floating. In this case, it is not necessary for the seat to move, because the back-support and/or leg-support are moving.

In an optional exemplary embodiment of the multi-position support apparatus of the
10 present invention, a feces-collecting device, referred to herein as "integrated toilet", can be integrated into multi-position support apparatus 10. The integrated toilet features significant hygienic advantages. Exemplary integrated toilets include a toilet, toilet bowl, and lavatory seat.

There are cases where there is a need to secure the user to multi-position support
15 apparatus 10. For example, when the user is an elderly person suffering from Alzheimer's disease, dementia or amnesia.

Securing the user to the device can be done by using any means known in the art. For example, multi-position support apparatus 10 side-handles that close-in/envelop the user and hold the user in place, and/or support / stability / binding straps attached to the sides of
20 multi-position support apparatus 10.

FIG. 6 is an illustration of armrest 30, which enables the user of the present invention to enter multi-position support apparatus 10 from a comfortable and safe direction 31.

Entering multi-position support apparatus 10 comfortably is achieved using two handles, armrests, or hand supports, featuring different lengths. On one side, there is a
25 short handle for allowing easy entry into the device; on the other side, a long handle both supports the user and prevents the user from falling from the apparatus.

Moreover, the user can be secured at the knees while standing, to increase safety and stability.

30 In an optional exemplary embodiment of the present invention, it is possible to control the operation of the device of the present invention by one or more means of the following

options: (a) Operating the device using a control button that enables choosing the desired program. (b) Operating the device using a controller that identifies voice commands. (c) Automatic operation of the device by means of user-identification. (d) Identifying the user may be achieved by any method known in the art. For example: by means of voice or visual
5 aids, RFID, smart card, key, user's weight, control panel, etc.

After the device identifies the user, a personal program of a specific user is executed. Angles and velocities are examples of some of the parameters which can be saved in the personal program.

In another optional exemplary embodiment of the present invention, the device of the
10 present invention is operated manually. The manual operating program activates each step/stage according to instructions from either the user or any other human operator.

In another optional exemplary embodiment of the present invention, the device of the present invention is operated by an automatic program that activates all stages, sequentially.

In an optional exemplary embodiment of the present invention, the device is operated
15 by one of the following, or by a combination thereof: (a) the user, (b) an operator who is not the user, (c) from any place where it is possible to control the device's operations via remote control or any other remote operating means as known in the art, or, (d) automatically, using methods known in the art.

In an optional exemplary embodiment of the present invention, prior to executing the
20 program, the device activates a voice indicator that tells the user about the program to be executed. Only after the user confirms the voice-indicated selection does the device activate the program. The user can confirm execution of the program by any input means known in the art, such as pressing a confirmation button, or by voice-command.

An exemplary optional device of the present invention features an interface from
25 which a variety of operations are controlled. The controller may be operated by the following exemplary means: manual, keyboard, voice-activation, computer-connected, for example via RS232 or USB, remote activation such as by telephone or wireless network, or by any other means known in the art. In an optional exemplary embodiment of the present invention, there is the ability to back up all or some of the parameters that have been user-
30 customized. Examples of parameters that have undergone user-customization: User programs, angles, heights, and angular change velocity. Parameters customized for the user

may be saved in the device or in any computer, or memory element, capable of communicating with the bed.

In an optional exemplary embodiment of the present invention, the device of the present invention features a Built in Test (BIT). The BIT system may be used for fast
5 identification of failures. This capability enables the technician to more easily determine what action should be taken when coming to the user. This also makes it easier to provide price quotes to the user prior to responding for repairs. Optionally, the BIT results may be transferred to the technician's equipment via a phone line or wireless network, or any other
know in the art communication aid.

10 In an exemplary embodiment of the present invention, When installing the device at the user's site, the technician is able to set a combination of velocities, movement angles, and other parameters referred to herein as "operational customized parameters" of the device such that it is possible to fit the use of the device to the requirements, comfort and safety of the specific user. Optionally, the operational customized parameters are saved in a
15 memory element for future use.

It will be appreciated that the above described methods may be varied in many ways, including changing the order of method steps, and/or performing multiple steps concurrently. Many elderly people suffer from memory deficiencies, eyesight deterioration
20 and other problems that might cause them to be afraid to use the device of the present invention. Voice indication before every state change can calm down the user and improve the user's experience with the device of the present invention.

It is appreciated that certain features of the invention, which are, for clarity, described
25 in the context of separate embodiments, may also be provided in various combinations in a single embodiment. Conversely, various features of the invention, which are, for brevity, described in the context of a single embodiment, may also be provided separately or in any suitable sub-combination.

It is to be understood that the present invention is not limited in its application to the
30 details of the order or sequence of steps of operation or implementation of the device and

corresponding method set in the description, drawings, or examples of the present invention.

All publications, patents and patent applications mentioned in this specification are herein incorporated in their entirety by reference to the specification, to the same extent as if
5 each individual publication, patent or patent application was specifically and individually indicated to be incorporated herein by reference. In addition, citation or identification of any reference in this application shall not be construed as an admission that such reference is available as prior art to the present invention.

10 While the invention has been described in conjunction with specific embodiments and examples thereof, it is to be understood that they have been presented by way of example, and not limitation. Moreover, it is evident that many alternatives, modifications and variations will be apparent to those skilled in the art. Accordingly, it is intended to embrace all such alternatives, modifications and variations that fall within the spirit and broad scope of the appended claims and their equivalents.

WHAT IS CLAIMED IS:

1. A multi-position support apparatus able to change its angular position comprising:
 - (a) a back support,
 - (b) a seat,
 - (c) at least one leg support, and
 - (d) at least one motorized foot support,whereby, said at least one motorized foot support moves toward the head of said multi-position support apparatus until it reaches a user's feet when said user wishes to stand up from lying down or reclining or sitting.
2. The multi-position support apparatus of claim 1 wherein said at least one motorized foot support comprises a sensor.
3. The multi-position support apparatus of claim 2 wherein said sensor is a pressure sensor, whereby said pressure sensor measures the intensity of the resistance from the user's legs.
4. The multi-position support apparatus of claim 1 wherein said multi-position support apparatus is covered by a mattress.
5. The multi-position support apparatus of claim 4 wherein said at least one motorized foot support is connected to an operating engine through slots in said mattress.
6. The multi-position support apparatus of claim 1 wherein said at least one motorized foot support is connected to an operating engine using at least one arm-like extension.
7. The multi-position support apparatus of claim 1 wherein said multi-position support apparatus further comprises:
 - (a) a multi-position support apparatus base,
 - (b) at least one hand support, and
 - (c) an integrated toilet.
8. The multi-position support apparatus of claim 1 wherein said multi-position support apparatus comprises:
 - (a) at least one engine to change said multi-position support apparatus angular position, and

- (b) at least one control system, whereby said at least one control system is controlling said at least one engine and said at least one motorized foot support,
- whereby said at least one control system prevents said user from getting to an angular position from which said user is able to fall forward from said multi-position support apparatus.
9. The multi-position support apparatus of claim 8 wherein said user controls said multi-position support apparatus by using controlling means.
 10. The multi-position support apparatus of claim 8 comprising two engines to change said multi-position support apparatus angular position and said control system allows said user to operate each engine separately.
 11. The multi-position support apparatus of claim 8 wherein said at least one motorized foot support comprises a sensor placed about said at least one motorized foot support, whereby said sensor detects objects and prevents said at least one motorized foot support from crushing them.
 12. The multi-position support apparatus of claim 8 wherein said back support comprises a sensor placed about said back support, whereby said sensor detects objects and prevents said back support from crushing them.
 13. The multi-position support apparatus of claim 1 wherein said multi-position support apparatus is a parallelogram-based multi-position support apparatus.
 14. The multi-position support apparatus of claim 1 wherein the length of said multi-position support apparatus is adjusted to the height of said user.
 15. The multi-position support apparatus of claim 1 wherein at least one part of said multi-position support apparatus is a floating part, whereby the at least one floating part enables said multi-position support apparatus to move according to the motion of said user .
 16. The multi-position support apparatus of claim 1 further comprising at least one device for entering an emergency response operation.
 17. The multi-position support apparatus of claim 1 further comprising customized operational parameters setting and saving means.

18. The multi-position support apparatus of claim 1 wherein said multi-position support apparatus is adjustable between lying, reclining, and standing positions, whereby said multi-position support apparatus is generally vertical in said standing position.
19. The multi-position support apparatus of claim 1 wherein said multi-position support apparatus is adjustable between reclining and standing positions.
20. The multi-position support apparatus of claim 1 wherein said multi-position support apparatus is adjustable between sitting and standing positions.
21. The multi-position support apparatus of claim 1 wherein said multi-position support apparatus further comprises wheels, whereby said wheels enable said multi-position support apparatus to move.
22. The multi-position support apparatus of claim 1 wherein said multi-position support apparatus further comprises a foldable tray attached to said multi-position support apparatus.
23. A multi-position support apparatus able to change its angular position comprising:
 - (a) a motorized foot support, and
 - (b) a muscle tonus monitoring device,whereby, said motorized foot support is able to move towards the head of said multi-position support apparatus and to move in an perpendicular direction.
24. The multi-position support apparatus of claim 23 further comprising motorized protective barriers.
25. The multi-position support apparatus of claim 23 wherein said motorized foot support comprises a pressure sensor, whereby said pressure sensor measures the intensity of the resistance from said user's legs.
26. The multi-position support apparatus of claim 23 wherein said multi-position support apparatus is covered by a mattress.
27. The multi-position support apparatus of claim 26 wherein said motorized foot support is connected to an operating engine through slots in said mattress.
28. The multi-position support apparatus of claim 23 wherein said motorized foot support is connected to an operating engine using at least one arm-like extension.
29. A method comprising:

- (a) providing a multi-position support apparatus accepting a user in a standing position,
 - (b) moving said user into a predefined reclining position,
 - (c) providing a motorized foot support,
 - (d) moving said motorized foot support towards the head of said multi-position support apparatus until it is reaching said user's feet,
 - (e) returning said user to a standing position, and
 - (f) moving said motorized foot support towards the floor.
30. The method of claim 29 wherein said reclining position is a lying position.
31. The method of claim 29 wherein said moving of said user into a predefined reclining position comprises leaning said user backwards, and upon achieving a predefined intermediate reclined angle, moving said user into said predefined reclining position; and said returning of said user to a standing position comprises moving said user into a predefined intermediate reclined angle, and upon achieving said predefined reclining position moving said user into said standing position.
32. The method of claim 29 wherein said returning of said user to said standing position comprises detecting objects and preventing said multi-position support apparatus from crushing them.
33. The method of claim 29 wherein said moving of said user into said predefined reclining position comprises detecting objects and preventing said multi-position support apparatus from crushing them.
34. The method of claim 29 wherein said reaching of said user's feet comprises measuring a minimum predefined intensity of resistance from said user's legs.
35. A method comprising:
- (a) providing a multi-position support apparatus accepting a user in a standing position,
 - (b) moving said user into a predefined reclining position,
 - (c) providing a motorized foot support,
 - (d) returning said user to a standing position,
 - (e) recognizing muscle tonus decrease, and
 - (f) preventing said user from falling.

36. The method of claim 35 wherein said preventing of said user from falling further comprises bringing said user back to a safe reclining position.
37. The method of claim 35 wherein said preventing of said user from falling further comprises upbringing motorized protective barriers.
38. The method of claim 35 wherein said preventing of said user from falling comprises pushing said user's feet forward.
39. The method of claim 35 wherein said preventing of said user from falling comprises pushing said user's knees forward.
40. The method of claim 35 further comprising returning said multi-position support apparatus to reclining position.
41. The method of claim 35 further comprising:
 - (a) moving said motorized foot support towards the head of said multi-position support apparatus until it reaches said user's feet, and
 - (b) moving said motorized foot support towards the floor.
42. The method of claim 35 wherein said reclining position is a lying position.
43. The method of claim 35 wherein said moving of said user into a predefined reclining position comprises leaning said user backwards, and upon achieving a predefined intermediate reclined angle, moving said user into said predefined reclining position; and said returning of said user to a standing position comprising moving said user into a predefined intermediate reclined angle, and upon achieving said predefined reclining position moving said user into said standing position.
44. The method of claim 35 wherein said returning of said user to said standing position comprises detecting objects and preventing said multi-position support apparatus from crushing them.
45. The method of claim 35 wherein said moving of said user into said predefined reclining position comprises detecting objects and preventing said multi-position support apparatus from crushing them.
46. The method of claim 41 wherein said moving said motorized foot support towards said head of said multi-position support apparatus until it is reaching said user's feet further comprises measuring a minimum predefined intensity of resistance from said user's legs.

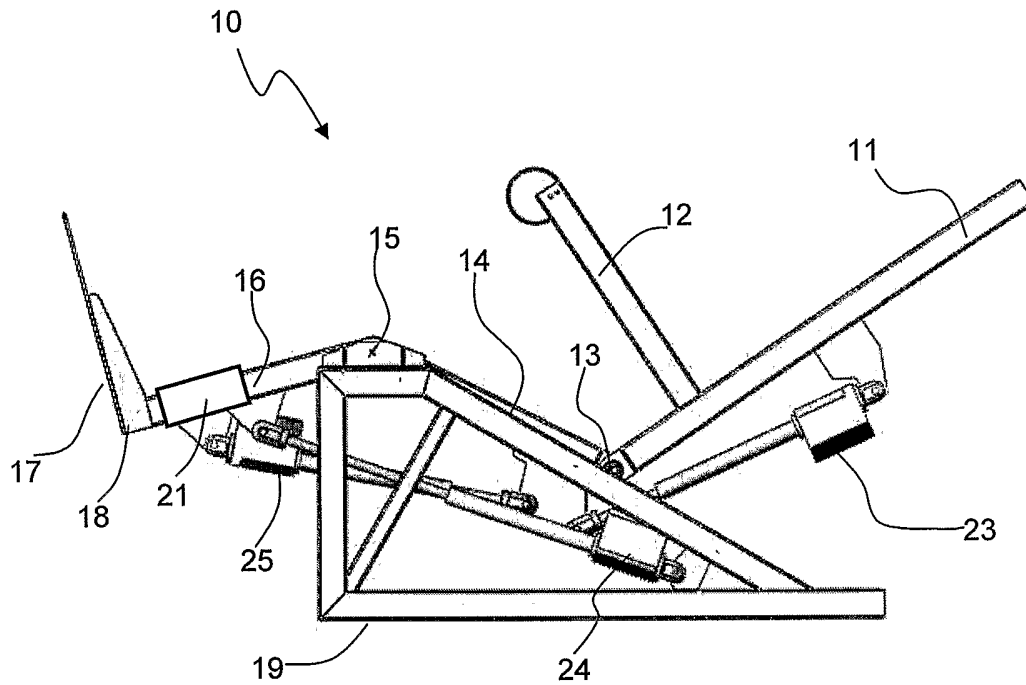

FIG. 1

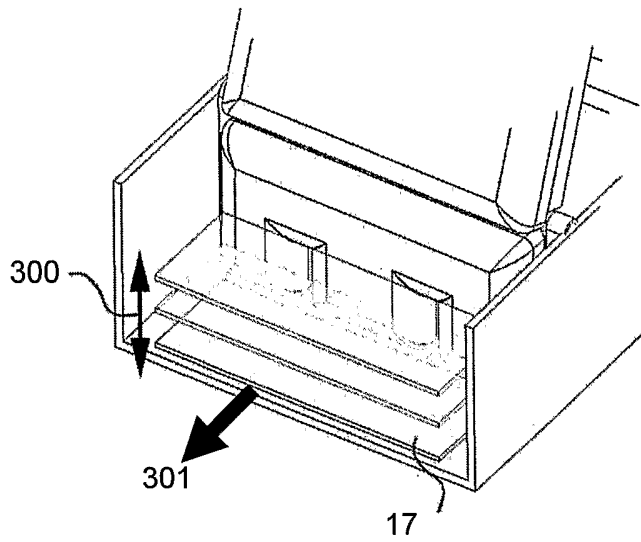

FIG. 2

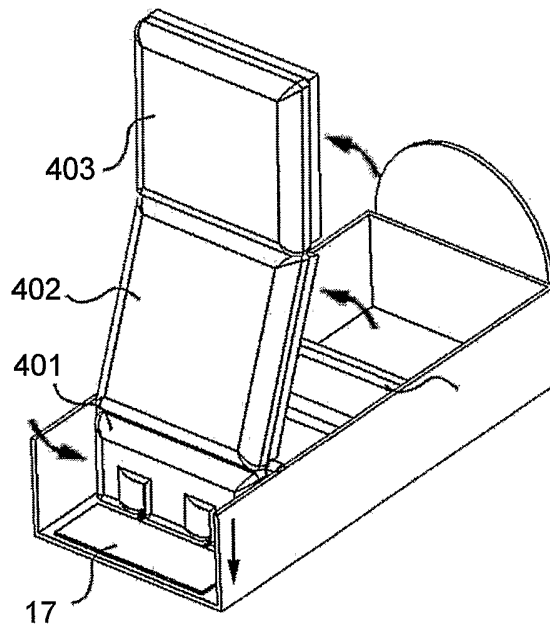

FIG. 3

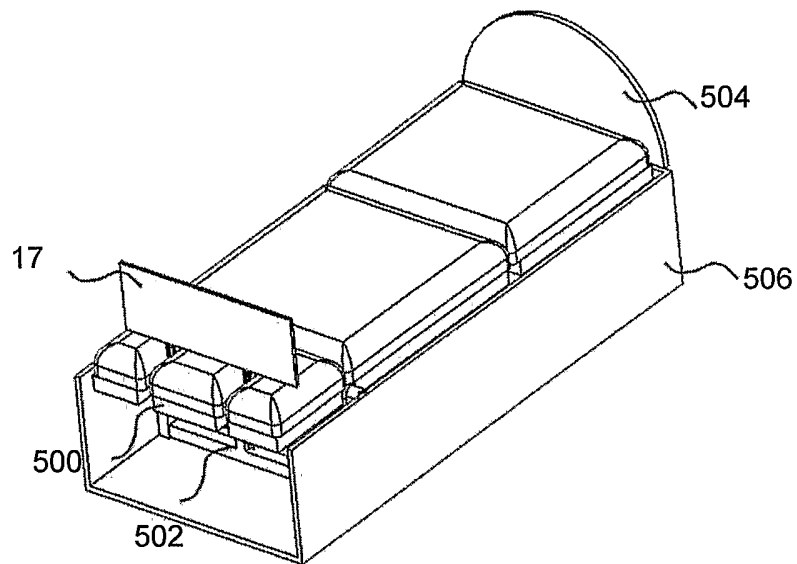

FIG. 4

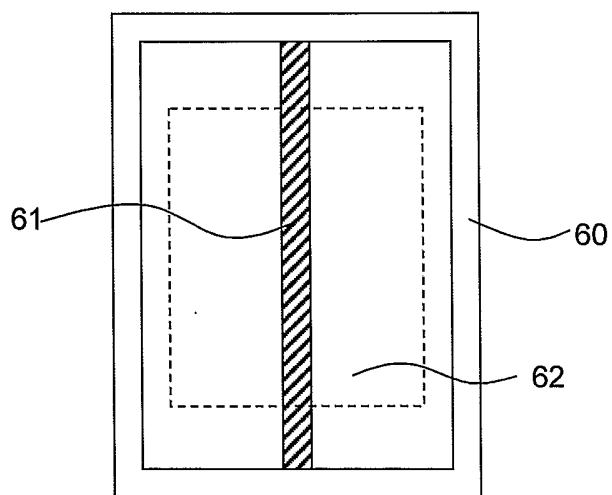

FIG. 5

4 / 6

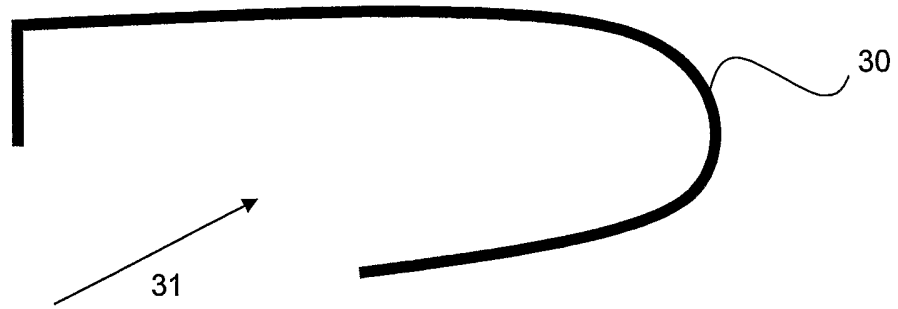

FIG. 6

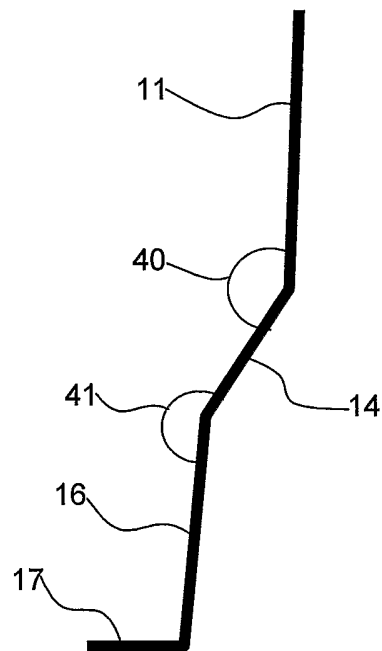

FIG. 7

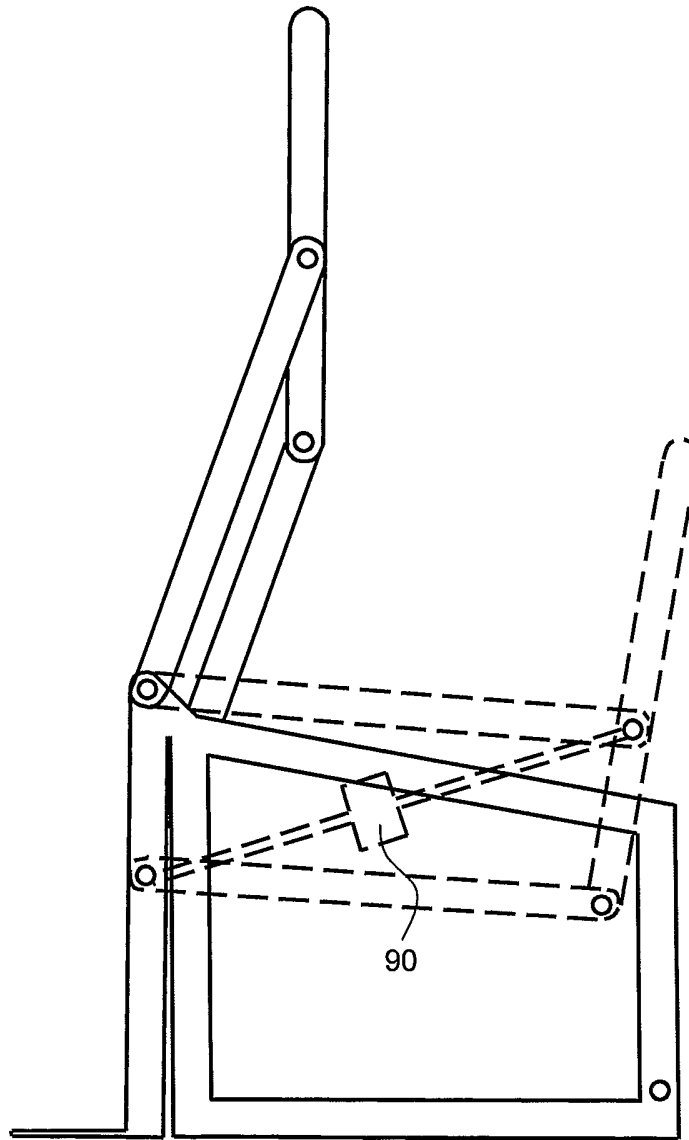

FIG. 8

6 / 6

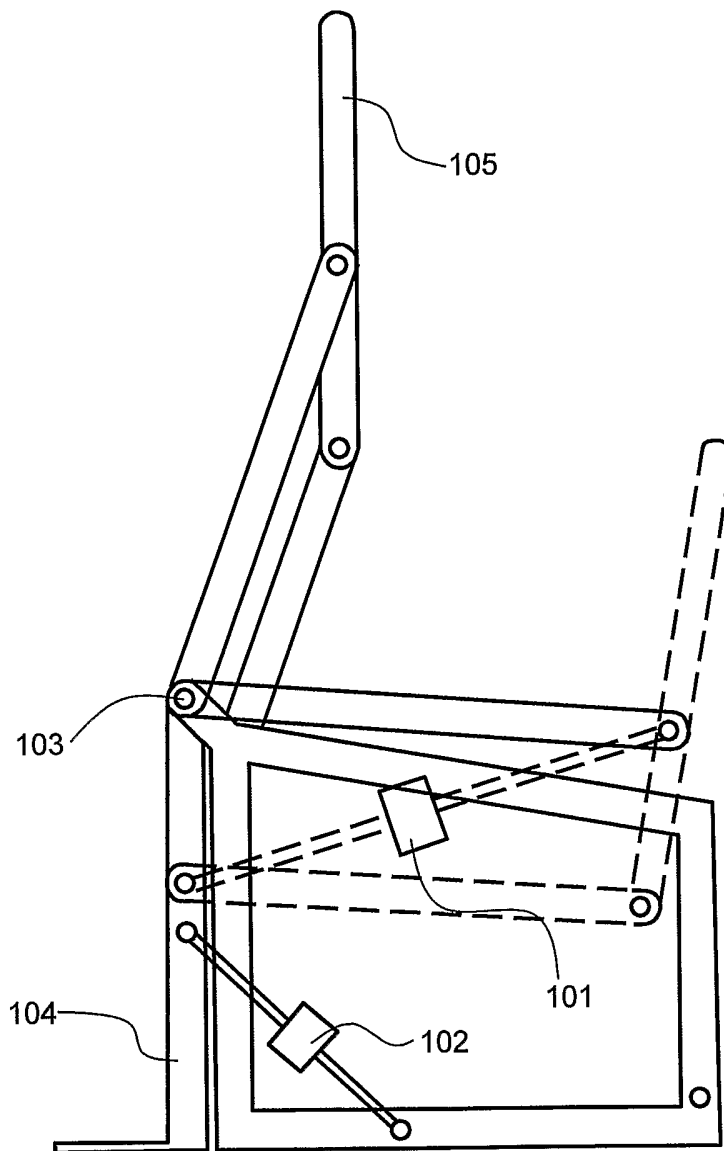

FIG. 9