

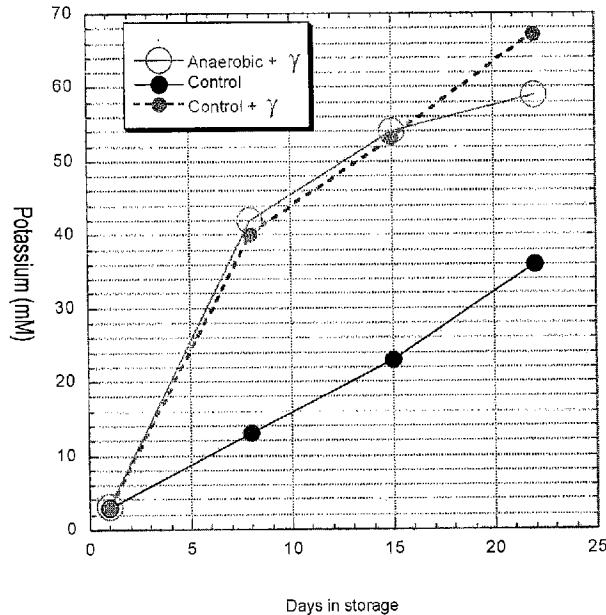

(86) Date de dépôt PCT/PCT Filing Date: 2011/11/04
 (87) Date publication PCT/PCT Publication Date: 2012/05/10
 (45) Date de délivrance/Issue Date: 2020/08/25
 (85) Entrée phase nationale/National Entry: 2013/05/06
 (86) N° demande PCT/PCT Application No.: US 2011/059372
 (87) N° publication PCT/PCT Publication No.: 2012/061731
 (30) Priorité/Priority: 2010/11/05 (US61/410,684)

(51) Cl.Int./Int.Cl. *A01N 1/02* (2006.01),
A61J 1/05 (2006.01), *C12N 5/078* (2010.01),
C12M 1/42 (2006.01), *C12N 13/00* (2006.01)
 (72) Inventeurs/Inventors:
 VERNUCCI, PAUL, US;
 YOSHIDA, TATSURO, US
 (73) Propriétaire/Owner:
 HEMANEXT INC., US
 (74) Agent: SMART & BIGGAR LLP

(54) Titre : IRRADIATION DES GLOBULES ROUGES ET CONSERVATION ANAEROBIE
 (54) Title: IRRADIATION OF RED BLOOD CELLS AND ANAEROBIC STORAGE



(57) Abrégé/Abstract:

A blood storage system comprising: a collection vessel for red blood cells; an oxygen or oxygen and carbon dioxide depletion device; a storage vessel for red blood cells; tubing connecting the collection vessel to the oxygen or oxygen and carbon dioxide depletion device and the oxygen or oxygen and carbon dioxide depletion device to the storage vessel; and a gamma or X-ray irradiating device is used to irradiate red blood cells stored in the vessel, storing red blood cells under anaerobic conditions.

(12) INTERNATIONAL APPLICATION PUBLISHED UNDER THE PATENT COOPERATION TREATY (PCT)

(19) World Intellectual Property Organization
International Bureau(43) International Publication Date
10 May 2012 (10.05.2012)

PCT

(10) International Publication Number
WO 2012/061731 A1(51) International Patent Classification:
A01N 1/02 (2006.01) C12N 5/02 (2006.01)(21) International Application Number:
PCT/US2011/059372(22) International Filing Date:
4 November 2011 (04.11.2011)

(25) Filing Language: English

(26) Publication Language: English

(30) Priority Data:
61/410,684 5 November 2010 (05.11.2010) US(71) Applicants (for all designated States except US): NEW
HEALTH SCIENCES [US/US]; 6903 Rockledge Drive,
Suite 230, Bethesda, MD 20817-1818 (US). YOSHIDA,
Tatsuro [JP/US]; 1763 Commonwealth Avenue, West
Newton, MA 02465 (US).

(72) Inventor; and

(75) Inventor/Applicant (for US only): VERNUCCI, Paul
[US/US]; 7 Dyer Street, Billerica, MA 01862 (US).(74) Agent: GREELEY, Paul, D.; Ohlandt, Greeley, Rug-
giero & Perle, L.L.P., One Landmark Square, 10th Floor,
Stamford, CT 06901-2682 (US).(81) Designated States (unless otherwise indicated, for every
kind of national protection available): AE, AG, AL, AM,
AO, AT, AU, AZ, BA, BB, BG, BH, BR, BW, BY, BZ,
CA, CH, CL, CN, CO, CR, CU, CZ, DE, DK, DM, DO,
DZ, EC, EE, EG, ES, FI, GB, GD, GE, GH, GM, GT,
HN, HR, HU, ID, IL, IN, IS, JP, KE, KG, KM, KN, KP,
KR, KZ, LA, LC, LK, LR, LS, LT, LU, LY, MA, MD,
ME, MG, MK, MN, MW, MX, MY, MZ, NA, NG, NI,
NO, NZ, OM, PE, PG, PH, PL, PT, QA, RO, RS, RU,
RW, SC, SD, SE, SG, SK, SL, SM, ST, SV, SY, TH, TJ,
TM, TN, TR, TT, TZ, UA, UG, US, UZ, VC, VN, ZA,
ZM, ZW.(84) Designated States (unless otherwise indicated, for every
kind of regional protection available): ARIPO (BW, GH,
GM, KE, LR, LS, MW, MZ, NA, RW, SD, SL, SZ, TZ,
UG, ZM, ZW), Eurasian (AM, AZ, BY, KG, KZ, MD,
RU, TJ, TM), European (AL, AT, BE, BG, CH, CY, CZ,
DE, DK, EE, ES, FI, FR, GB, GR, HR, HU, IE, IS, IT,
LT, LU, LV, MC, MK, MT, NL, NO, PL, PT, RO, RS,

[Continued on next page]

(54) Title: IRRADIATION OF RED BLOOD CELLS AND ANAEROBIC STORAGE

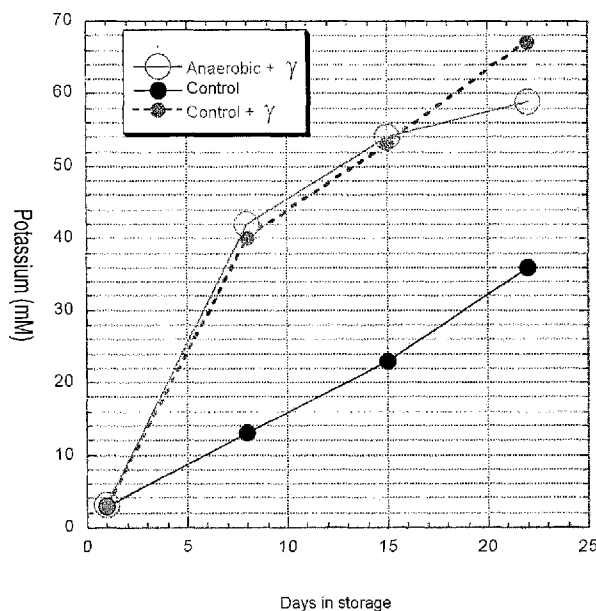

FIG. 13

(57) Abstract: A blood storage system comprising: a collection vessel for red blood cells; an oxygen or oxygen and carbon dioxide depletion device; a storage vessel for red blood cells; tubing connecting the collection vessel to the oxygen or oxygen and carbon dioxide depletion device and the oxygen or oxygen and carbon dioxide depletion device to the storage vessel; and a gamma or X-ray irradiating device is used to irradiate red blood cells stored in the vessel, storing red blood cells under anaerobic conditions.

WO 2012/061731 A1 

SE, SI, SK, SM, TR), OAPI (BF, BJ, CF, CG, CI, CM, GA, GN, GQ, GW, ML, MR, NE, SN, TD, TG).

Published:

Declarations under Rule 4.17:

— of inventorship (Rule 4.17(iv))

— with international search report (Art. 21(3))

— before the expiration of the time limit for amending the claims and to be republished in the event of receipt of amendments (Rule 48.2(h))

IRRADIATION OF RED BLOOD CELLS AND ANAEROBIC STORAGE

BACKGROUND

5

1. FIELD

The present disclosure relates to a storage blood system having an oxygen/carbon dioxide depletion device and a blood storage bag for the long-term storage of red blood cells (RBCs). More particularly, the present disclosure relates to a blood storage system that is capable of removing oxygen and carbon dioxide from the red blood cells prior to storage and gamma and/or X-ray irradiating red blood cells either pre- or post-anaerobic treatment, as well as maintaining oxygen or oxygen and carbon dioxide depleted states during storage, thereby prolonging the storage life and minimizing deterioration of the deoxygenated red blood cells.

10
15

2. BACKGROUND OF THE ART

Adequate blood supply and the storage thereof is a problem facing every major hospital and health organization around the world. Often, the amount of blood supply in storage is considerably smaller than the need therefore. This is especially true during crisis periods such as natural catastrophes, war and the like, when the blood supply is often perilously close to running out. It is at critical times such as these that the cry for more donations of fresh blood is often heard. However, unfortunately, even when there is no crisis period, the blood supply and that kept in storage must be constantly monitored and replenished, because stored blood does not maintain its viability for long.

20
25

Stored blood undergoes steady deterioration which is, in part, caused by hemoglobin oxidation and degradation and adenosine triphosphate (ATP) and 2-3,biphosphoglycerate (DPG) depletion. Oxygen causes hemoglobin (Hb) carried by the red blood cells (RBCs) to convert to met-Hb, the breakdown of

30

which produces toxic products such as hemichrome, hemein and free Fe^{3+} . Together with the oxygen, these products catalyze the formation of hydroxyl radicals (OH.cndot.), and both the OH.cndot. and the met-Hb breakdown products damage the red blood cell lipid membrane, the membrane skeleton, and the cell contents. As such, stored blood is considered unusable after 6 weeks, as determined by the relative inability of the red blood cells to survive in the circulation of the transfusion recipient. The depletion of DPG prevents adequate transport of oxygen to tissue thereby lowering the efficacy of transfusion immediately after administration (levels of DPG recover once in recipient after 8-48 hrs). In addition, these deleterious effects also result in reduced overall efficacy and increased side effects of transfusion therapy with stored blood before expiration date, when blood older than two weeks is used. Reduction in carbon dioxide content in stored blood has the beneficial effect of elevating DPG levels in red blood cells.

15

There is, therefore, a need to be able to deplete oxygen and carbon dioxide levels in red blood cells prior to storage on a long-term basis without the stored blood undergoing the harmful effects caused by the oxygen and hemoglobin interaction. Furthermore, there is a need to store oxygen and carbon dioxide depleted red blood cells in bags containing or in a bag surrounded by a barrier film with oxygen and carbon dioxide depletion materials. Furthermore, there is a need to optimize ATP and DPG levels in stored red blood cells by varying the depletion or scavenging constituents prior to and/or during storage depending upon the needs of the recipient upon transfusion. Furthermore, the blood storage devices and methods must be simple, inexpensive and capable of long-term storage of the blood supply.

Another issue relates to transfusion-associated graft-versus-host disease (TA-GVHD) which is a rare but nearly fatal complication associated with transfusion therapy in severely immuno-compromised blood recipients (for example, bone marrow transplant recipient, patients receiving aggressive

30

chemotherapy, premature neonates). Prevention of TA-GVHD requires complete removal of, or arrest of the proliferative potential of T-lymphocytes from donor blood. Although leuko reduction filters are widely in use, they are not adequate in prevention of TA-GVHD because it cannot completely eliminate lymphocytes. Thus, lymphocyte inactivation by gamma-irradiation is currently the only recommended method for TA-GVHD prevention. Since it is a nearly fatal side effect of transfusion, some hospitals and countries irradiate every unit of RBC for TA-GVHD prevention. More commonly, RBC units ordered for specific recipients are irradiated before dispensed to the bedside.

10

Accordingly, anaerobically stored RBC must be compatible with gamma- or X-ray irradiation treatment so that anaerobically stored blood can be transfused to patients requiring irradiated RBC.

15

Gamma-irradiation abrogates proliferation of T-lymphocytes by damaging the DNA directly and via reactive oxygen species (ROS), namely hydroxyl radicals produced during gamma-radiolysis of water. Although red blood cells (RBC) do not contain DNA, ROS generated by gamma-irradiation have been shown to cause significant damage to the RBC. The major damage observed includes: i) increased hemolysis; ii) increased K⁺ leak; iii) reduction in post-transfusion survival; and iv) reduced deformability. Such damage is similar to, but an exaggerated form of storage-induced damage of RBC. The compromised status of RBC is well known to the physicians who administer such compromised RBC. The FDA mandates restricted use of such RBC in terms of shortened shelf life after gamma-irradiation (14 days) and/or 28 days total shelf life for irradiated units.

20

The irradiation of blood components has received increased attention due to increasing categories of patients eligible to receive such blood to prevent transfusion-associated graft versus host disease. However, irradiation leads to enhancement of storage lesions, which could have deleterious effects when such

25

30

blood is transfused. It is well known in the field that the main deleterious side-effect of radiation on RBC is oxidative damage caused by ROS.

5 Radiation damage to RBC in the presence of oxygen can occur in two ways;

- 10 i) By ROS generated during and immediately after irradiation. ROS can reside in RBC lipid, then attack proteins and lipids in vicinity later during storage, as well as to initiate peroxidation cycle of lipid and protein using oxygen to fuel.
- 15 ii) Met-Hb and its denaturation products generated in i) above act as catalysts to further cause ROS-mediated oxidative damage during subsequent extended refrigerated storage of RBC. This is an enhanced version of storage lesion development using O₂.

15

 On the other hand, there is ample literature suggesting ROS as a major culprit in causing deterioration of red blood cell (RBC) during refrigerated storage at blood banks, and that storing RBC under anaerobic condition significantly reduce such damages. Studies have shown that irradiated red blood
20 cells that are oxygen and oxygen and carbon dioxide depleted are equivalent or healthier (in terms of K⁺ leakage, hemolysis and oxidized proteins/lipids) in comparison to non-irradiated and non-oxygen and carbon dioxide depleted blood and non-oxygen and carbon dioxide depleted irradiated blood. In the context of the present application, the higher concentration of potassium in
25 RBC storage media was at levels that indicated red blood cell damage. The present disclosure applies the finding of compatibility of gamma-irradiation with anaerobically stored blood, as well as the protective effects of anaerobic conditions in enhancing ATP, DPG and in reducing oxidative damage during refrigerated storage, to substantially reduce the negative or deleterious effect of
30 gamma- and X-ray irradiation of RBCs in the presence of oxygen.

U.S. Patent No. US Patent 5,362,442 to Kent describes adding a scavenger to bind free radicals such as ethanol. U.S. Patent No. 61875572 to Platz et al. describes adding chemical sensitizers; U.S. Patent No. 6,482,585 to Dottori and U.S. Patent No. 6,403,124, also to Dottori, describe adding
5 L-carnitine or an alkanoul derivative to reduce RBC cell membrane damage induced by irradiation. These additives are not required to prevent the deleterious effects of irradiation on RBCs when treated anaerobically.

10 SUMMARY

A method and system for gamma or X-ray irradiation of RBC under anaerobic or anaerobic and CO₂ depleted conditions, and extended refrigerated storage of such RBC under anaerobic or anaerobic and/or CO₂ depleted conditions using an oxygen and/or CO₂ depletion device.

15

A method and system for removing plasma with or without platelets, adding an additive solution (e.g., nutrient and/or metabolic supplements) to the concentrated RBC, filtering out leukocytes and/or platelets via a leuko reduction filter, removing oxygen and/or CO₂ from the filtered RBC, and gamma
20 irradiating or X-ray irradiating the oxygen and/or CO₂ filtered RBC either prior to or during storage thereof. The preferred range of gamma irradiation is a minimum of between about 25 Gy to 50 Gy.

Gamma or X-ray irradiating RBC under anaerobic or anaerobic and CO₂
25 conditions (ambient to 1°C) defined as less than 20% SO₂ (oxygen-saturation of hemoglobin), more preferably less than 5%, and most preferably less than 3%.

Storing gamma or X-ray irradiated (either under anaerobic or anaerobic and CO₂ conditions) RBC for extended time at 1-6°C under anaerobic condition
30 defined as less than 20% SO₂ (oxygen-saturation of hemoglobin), more preferably less than 5%, and most preferably less than 3%.

Gamma or x-ray irradiating RBC under anaerobic or anaerobic and CO₂ depleted conditions (ambient to 1°C) defined as less than 20% SO₂ (oxygen-saturation of hemoglobin), more preferably SO₂ < 5%, and most preferably SO₂ <3% and pCO₂ <10mmHg; pCO₂<5mmHg; pCO₂<1mmHg.

Gamma or x-ray irradiating RBC under aerobic conditions (ambient to 1°C) and then removing oxygen or oxygen and carbon dioxide from the irradiated RBC to levels defined as less than 20% SO₂ (oxygen-saturation of hemoglobin), more preferably SO₂ < 5%, and most preferably SO₂ <3% and pCO₂ <10mmHg; pCO₂<5mmHg; pCO₂<1mmHg. The gamma or x-ray irradiation under aerobic conditions and removal of oxygen or oxygen and carbon dioxide can be performed before placing blood for extended storage, or within 24 hr of blood collection, between 1 through 7 days after blood collection or beyond 7 days.

Using older blood, defined as blood stored for more than one week, and exposing such blood to gamma or x-ray irradiating RBC under aerobic conditions (ambient to 1°C) and then removing oxygen or oxygen and carbon dioxide from the irradiated RBC to levels defined as less than 20% SO₂ (oxygen-saturation of hemoglobin), more preferably SO₂ < 5%, and most preferably SO₂ <3% and pCO₂ <10mmHg; pCO₂<5mmHg; pCO₂<1mmHg.

Using older blood, defined as blood stored for more than one week, and removing oxygen or oxygen and carbon dioxide from such older blood and exposing such blood to Gamma or x-ray irradiation at wherein the levels of oxygen and carbon dioxide are levels defined as less than 20% SO₂ (oxygen-saturation of hemoglobin), more preferably SO₂ < 5%, and most preferably SO₂ <3% and pCO₂ <10mmHg; pCO₂<5mmHg; pCO₂<1mmHg.

30

Storing gamma or X-ray irradiated or pre-irradiated RBC (either under anaerobic conditions with or without CO₂ depletion) RBC for extended time at 1-6°C under anaerobic or anaerobic and CO₂ depleted condition defined as less than 20% SO₂ (oxygen-saturation of hemoglobin), more preferably less than 5%, and most preferably 3% and less than pCO₂<10mmHg; pCO₂<5mmHg; pCO₂<1mmHg.

A preferred embodiment includes a blood storage system comprising: a collection vessel for red blood cells; an oxygen or oxygen/carbon dioxide depletion device; tubing connecting the collection vessel to the oxygen or oxygen/carbon dioxide depletion device and the storage vessel for red blood cells that can be gamma or X-ray irradiated and stored under anaerobic or anaerobic and CO₂ depleted condition for extended time.

Preferably, the anaerobic or anaerobic and CO₂ condition is measured as an oxygen-saturation of hemoglobin of less than 20% SO₂, preferably about 5% or less, and most preferably about 3% or less.

The oxygen or oxygen/carbon dioxide depletion device comprises: a cartridge; a plurality of gas permeable hollow fibers or sheets extending within the cartridge from an entrance to an exit thereof, wherein the hollow fibers or gas-permeable films are adapted to receiving and conveying red blood cells; and an amount of an oxygen scavenger or both oxygen scavenger and a carbon dioxide scavenger packed within the cartridge and contiguous to and in between the plurality of hollow fibers.

Preferably, the oxygen or oxygen/carbon dioxide depletion device comprises: a cartridge; a plurality of hollow fibers or gas-permeable films extending within the cartridge from an entrance to an exit thereof, wherein the hollow fibers or gas-permeable films are adapted to receiving and conveying red blood cells; and a low oxygen or a low oxygen and carbon dioxide environment

is created outside the hollow fibers by flowing an inert gas in-between the hollow fibers.

5 The blood storage system further comprising a leuko reduction filter disposed between the collection vessel and the oxygen/carbon dioxide depletion device. The blood storage system further comprising an additive solution vessel in communication with the collection vessel. The blood storage system further comprising a plasma vessel in communication with the collection vessel.

10 A method for storing red blood cells, the method comprising: removing oxygen or oxygen and carbon dioxide from red blood cells to produce anaerobic red blood cells; and storing irradiated RBC with either gamma- or X-ray, thereby producing irradiated anaerobic red blood cells; and storing the irradiated anaerobic or anaerobic and CO₂ depleted red blood cells.

15 The irradiated anaerobic or irradiated anaerobic and CO₂ depleted red blood cells are preferably stored at a temperature from between about 1°C to about 6°C under anaerobic conditions.

20 The present disclosure also provides for a device and method of removing carbon dioxide (CO₂) in addition to oxygen (O₂) prior to or at the onset of anaerobic or anaerobic and CO₂ depleted storage and/or gamma or X-ray irradiation.

25 The present disclosure provides for a blood collection system that incorporates an oxygen or oxygen/carbon dioxide depletion device having an oxygen or oxygen and carbon dioxide sorbent in combination with a filter or membrane to strip oxygen or oxygen and carbon dioxide from the blood during transport to the storage bag, wherein the oxygen/carbon dioxide depleted blood
30 is gamma or X-ray irradiated either prior to or during storage.

The present disclosure further provides for a system to deplete the oxygen or oxygen and carbon dioxide from collected red blood cells that includes an (optional additive solution), an oxygen or oxygen and carbon dioxide depletion device, and a blood storage bag that maintains the red blood cells in an oxygen or oxygen and carbon dioxide depleted state after
5 gamma- or X-ray irradiation.

The present invention as claimed relates to:

- a blood storage system for preparing irradiated red blood cells comprising: a
10 collection vessel for red blood cells; an oxygen or oxygen and carbon dioxide depletion device; a storage vessel for storing oxygen or oxygen and carbon dioxide-depleted red blood cells under anaerobic conditions; a first tubing connecting the collection vessel to the oxygen or oxygen and carbon dioxide depletion device; and a second tubing connecting the oxygen or oxygen and carbon dioxide depletion device to the storage vessel; wherein said oxygen or
15 oxygen and carbon dioxide-depleted red blood cells are capable of being irradiated with a gamma or X-ray irradiating device, when stored in said storage vessel, and wherein irradiation damage to said oxygen or oxygen and carbon dioxide-depleted red blood cells is reduced without the addition of L-carnitine or an alkanoul derivative to said blood storage system;

20 - a method for reducing radiation damage in red blood cells, said method comprising: removing oxygen or oxygen and carbon dioxide from red blood cells, thereby producing oxygen- or oxygen and carbon dioxide-depleted red blood cells; and irradiating said oxygen- or oxygen and carbon dioxide-depleted red blood cells via either gamma or X-ray irradiation in the absence of L-carnitine, thereby producing irradiated oxygen- or oxygen and carbon
25 dioxide-depleted red blood cells;

- a method for storing red blood cells, said method comprising: removing oxygen or oxygen and carbon dioxide from said red blood cells, thereby producing anaerobic red blood cell; irradiating red blood cells via either gamma or X-ray irradiation, thereby producing
30 irradiated anaerobic red blood cells; and storing said irradiated anaerobic red blood cells under anaerobic conditions that do not include L-carnitine or an alkanaoul derivative; and

- a composition comprising: irradiated oxygen or oxygen and carbon dioxide depleted red blood cells, wherein said oxygen depleted red blood cells comprise an oxygen-saturation of hemoglobin (SO₂) level of less than 20% and said oxygen and carbon dioxide depleted red blood cells comprise an oxygen-saturation of hemoglobin (SO₂) level of less than 20% and a
5 partial pressure of carbon dioxide (pCO₂) of less than 10 mmHg.

The present disclosure and its features and advantages will become more apparent from the following detailed description with reference to the accompanying drawings.

10 **BRIEF DESCRIPTION OF THE DRAWINGS**

Fig. 1a illustrates the components of a gamma irradiated, disposable blood anaerobic storage system of the present disclosure.

15 Fig. 1b illustrates the components of a second embodiment of a gamma irradiated, disposable blood anaerobic storage system of the present disclosure.

Fig. 2a illustrates the components of an embodiment of a disposable blood anaerobic storage system that are used in conjunction with RBC irradiation in which red blood cells are
20 irradiated during anaerobic storage.

Fig. 2b illustrates the components of a second embodiment of a disposable blood anaerobic storage system that are used in conjunction with RBC irradiation.

25 Fig. 3 illustrates a pre-storage oxygen/carbon dioxide depletion device of the present disclosure.

Fig. 4 illustrates a first embodiment of a blood storage bag having a storage bag with a secondary outer oxygen film containing an oxygen sorbent in a pocket.

5 Fig. 5a illustrates a pre-storage oxygen/carbon dioxide depletion bag having a blood storage bag with a large sorbent sachet enclosed in gas-permeable, red blood cell compatible polymers in contact with the RBCs.

10 Fig. 5b illustrates a third embodiment of a blood storage bag having a storage bag a laminated oxygen film barrier with a large sorbent in contact with the RBCs.

15 Fig. 6a illustrates a fourth embodiment of a blood storage bag having a secondary configured secondary outer barrier bag surrounding an inner blood storage bag having an oxygen sorbent.

20 Fig. 6b illustrates a fifth embodiment of a blood storage bag having a secondary outer barrier bag surrounding an inner blood storage bag having a large oxygen sorbent sachet enclosed in a gas permeable, red blood cell compatible polymers in contact with RBCs.

25 Figs. 7a through 7c illustrate an embodiment of a depletion device that depletes oxygen and carbon dioxide from red blood cells prior to storage by a flushing inert gas or inert gas /CO₂ mixture of defined composition around a hollow fiber inside the assembly.

Figs. 8a through 8c illustrate another embodiment of a depletion device that depletes oxygen and carbon dioxide from red blood cell prior to storage.

30 Figs. 9a through 9c illustrate another embodiment of a depletion device that depletes oxygen and carbon dioxide from red blood cells prior to storage

wherein oxygen and CO₂ is scavenged by scavenger materials in the core of the cylinder, surrounded by hollow fibers.

5 Figs. 10a through 10c illustrate another embodiment of a depletion device that depletes oxygen and carbon dioxide from red blood cells prior to storage wherein oxygen and CO₂ is scavenged by scavenger materials surrounding cylinders of hollow fibers enveloped in gas permeable, low water vapor transmission material.

10 Fig. 11 illustrates a plot of flow rate of RBC suspension per minute versus oxygen partial pressure for the depletion devices of Figs. 7a through 7c, Figs. 8a through 8c, Figs. 9a through 9c and Figs. 10a through 10c.

15 Figs 12a through 12h illustrate plots of the effect of oxygen and oxygen and carbon dioxide depletion on metabolic status of red blood cells during refrigerated storage.

20 Fig 13 illustrates an effect of gamma-irradiation on K⁺ leak rates from RBC (as measured by free K⁺ concentrations in RBC suspending media after storage).

DETAILED DESCRIPTION OF THE PREFERRED EMBODIMENT

25 RBCs do not require oxygen for their own survival. It was shown previously that when RBCs were stored in blood bank refrigerator (1-6°C) under anaerobic or anaerobic and CO₂ depleted conditions, they demonstrated significantly improved post-transfusion recovery after 6-week storage compared to the conventionally stored controls. The mechanisms of reduction in storage lesions under anaerobic or anaerobic/CO₂ depleted conditions have been
30 described and direct evidences demonstrated. It is, at least in part, due to

reduction in oxidative damages in the presence of O₂ caused by ROS during refrigerated storage.

Because gamma- or X-ray irradiation exacerbate oxidative damage on treated RBC, storing irradiated RBC under anaerobic and, optionally, CO₂ depleted condition is not expected to intensify the damage; it is also expected to prevent damage resulting from ROS generated during irradiation by depriving O₂ that fuels those reactions.

Effectiveness of gamma- or X-ray irradiation is not dependent on the presence of oxygen. In contrast, anaerobic condition is shown to be more effective in causing damage to DNA (and thus inhibiting proliferation of lymphocytes). Furthermore, absence of O₂ during and/or immediately after gamma- or X-ray irradiation will reduce O₂-fuelled oxidative damages to RBC induced by hydroxyl radicals and ROS produced by radiolysis of water with gamma- or X-rays.

Referring to the drawings and in particular to Fig. 1a, a disposable blood anaerobic storage system is shown and referenced using reference numeral 10. The blood storage system includes an oxygen/carbon dioxide depletion device 100 (OCDD 100), an anaerobic blood storage bag 200 and an additive solution bag 300. OCDD 100 removes oxygen and/or carbon dioxide from red blood cells traveling through it. The system also contains a leuko reduction filter 400. Components conventionally associated with the process of blood collection are a phlebotomy needle 410, a blood collection bag 420 containing an anti-coagulant and a bag 430 containing plasma. Tubing can connect the various components of the blood storage system 10 in various configurations (one embodiment shown). Tube 440 connects collection bag 420 with leuko reduction filter 400. Tube 441 connects additive solution bag 300 with collection bag 420. Tube 442 connects plasma bag 430 with collection bag 420. Tube 443 connects leukoreduction filter 400 with OCDD 100. Tube 414

connects OCDD 100 with blood storage bag 200. Blood storage system 10 is preferably a single-use, disposable, low cost system. As filtered and oxygen or oxygen and carbon dioxide depleted blood passes from OCDD 100 to blood storage bag 200. Blood stored in bag 200 will be gamma and/or X-ray irradiated during storage via device 453. Bag 200 containing oxygen depleted or oxygen and carbon dioxide depleted RBC is placed into device 453 and exposed to gamma and/or X-ray radiation. Alternatively, pre-anaerobic blood stored in collection bag 421 can be gamma and/or X-ray irradiated via device 445 before passing through OCDD 100 and stored in bag 200, as shown in Fig. 1b. In Fig. 1b, bag 420 could also be gamma and/or X-ray irradiated in an irradiating device 445 prior to passing through leukoreduction filter 400.

Oxygen or oxygen/carbon dioxide depletion device 100 removes the oxygen from collected RBCs prior to the RBCs being stored in blood storage bag 200. The oxygen content in RBCs must be depleted from oxy-hemoglobin because more than 99% of such oxygen is hemoglobin-bound in venous blood. Preferably, the degree of oxygen saturation is to be reduced to less than 4% within 48 hours of blood collection. The oxygen depletion is preferably accomplished at room temperature. The affinity of oxygen to hemoglobin is highly dependent on the temperature, with a p50 of 26 mmHg at 37° C dropping to ~4 mmHg at 4° C. Furthermore, this increase in O₂ affinity (K_a) is mainly due to reduction in O₂ release rate (k-off), resulting in an impractically low rate of oxygen removal once RBC is cooled to 4° C. Thus, it places a constraint on oxygen stripping such that it may be preferable to accomplish it before RBC are cooled to storage temperatures of 1° C to 6° C.

In addition to oxygen depletion, carbon dioxide depletion has the beneficial effect of elevating DPG levels in red blood cells. Carbon dioxide exists inside RBCs and in plasma in equilibrium with HCO₃⁻ ion (carbonic acid). Carbon dioxide is mainly dissolved in RBC/plasma mixture as carbonic acid and rapid equilibrium between CO₂ and carbonic acid is maintained by

carbonic anhydrase inside RBC. Carbon dioxide is freely permeable through RBC membrane, while HCO_3^- inside RBC and plasma is rapidly equilibrated by anion exchanger (band 3) protein. When CO_2 is removed from RBC suspension, it results in the known alkalization of RBC interior and suspending medium.

5 This results from removal of HCO_3^- inside and outside RBC; cytosolic HCO_3^- is converted to CO_2 by carbonic anhydrase and removed, while plasma HCO_3^- is removed via anion exchange inside RBC. Higher pH inside RBC is known to enhance the rate of glycolysis and thereby increasing ATP and DPG levels. ATP levels are higher in Ar/ CO_2 ($p < 0.0001$). DPG was maintained beyond 2

10 weeks in the Argon purged arm only ($p < 0.0001$). Enhanced glycolysis rate is also predicted by dis-inhibition of key glycolytic enzymes via metabolic modulation and sequesterization of cytosolic-free DPG upon deoxygenation of hemoglobin as a result of anaerobic condition. DPG was lost at the same rate in both control and Ar/ CO_2 arms ($p = 0.6$) despite thorough deoxygenation of

15 hemoglobin, while very high levels of ATP were achieved with OFAS3 additive (Figs. 12a-12d).

Referring to the drawings, and in particular to Fig. 2a, another embodiment of a disposable blood anaerobic storage system is shown and

20 referenced using reference numeral 500. The anaerobic conversion system includes an oxygen or oxygen/carbon dioxide depletion device 515 (OCDD) and an anaerobic blood storage bag 528. OCDD 515 removes oxygen or oxygen and carbon dioxide from red blood cells traveling through it. Tubing connects the various components of the blood storage system 500. Tube 512 connects to

25 RBC concentrate prepared by using an additive solution (e.g., AS1, AS3, AS5, SAGM, MAPS, etc.) and storing in bag 528 by passing aforementioned RBC concentrate from collection bag 510 through OCDD 515. Tubes 518 and 520 connect OCDD 515 with blood storage bag 528. Blood storage system 500 is preferably a single-use, disposable, low cost system. Oxygen and/or carbon

30 dioxide depleted blood is gamma and/or X-ray in blood storage bag 528 via device 553 and subsequently stored for later transfusion.

Alternatively, blood in collection bag 510 may be gamma- or X-ray irradiated via device 551 prior to oxygen or oxygen and carbon dioxide depletion and low temperature storage, as shown in Fig. 2b. Fig. 2b applies to the scenario in which blood bag 510 contains older, for example 2 day old blood, that is then irradiated and depleted of oxygen or oxygen and or carbon dioxide, and stored.

Referring to Fig. 3, an oxygen or oxygen/carbon dioxide depletion device (OCDD) 101 contains an oxygen sorbent 110. OCDD 101 is a disposable cartridge 105 containing oxygen sorbent 110 and a series of hollow fibers 115. Oxygen sorbent 110 is a mixture of non-toxic inorganic and/or organic salts and ferrous iron or other materials with high reactivity toward oxygen. Oxygen sorbent 110 is made from particles that have significant absorbing capacity for O₂ (more than 5 ml O₂/g) and can maintain the inside of cartridge 105 to less than 0.01% which corresponds to PO₂ less than 0.08 mmHg. Oxygen sorbent 110 is either free or contained in an oxygen permeable envelope. OCDD 101 of the present disclosure must deplete approximately 100 mL of oxygen from a unit of blood.

20

After oxygen and, optionally, carbon dioxide have been stripped from RBCs in the OCDD of Fig. 3, RBCs are stored in a blood storage bag 200. The oxygen content of RBC suspended in additive solution 300 must be reduced to equal to or less than 4% SO₂ before placing them in refrigerated storage. Further, oxygen depleted RBC must be kept in an anaerobic state and low carbon dioxide state throughout entire storage duration.

RBCs pass through an oxygen permeable film or membrane, that may be formed as hollow fibers 115 of Fig. 3. The membrane or films may be constructed in a flat sheet or hollow fiber form. The oxygen permeable films can be non porous materials that are capable of high oxygen permeability rates

30

(polyolefins, silicones, epoxies, polyesters, etc.) and oxygen permeable membranes are hydrophobic porous structures. These may be constructed of polymers (e.g., polyolefins, Teflon, PVDF, or polysulfone) or inorganic materials (e.g., ceramics). Oxygen depletion takes place as RBC pass through
5 hollow fibers 115. Oxygen permeable films or oxygen permeable membranes may be extruded into sheets or hollow fibers 15. Accordingly, hollow fibers 115 and sheets may be used interchangeably. OCDD provides a simple structure having a large surface area to remove oxygen and maintain constant flow of blood therethrough. The oxygen depletion or removal is accomplished
10 by irreversible reaction of ferrous ion in oxygen sorbent 110 with ambient oxygen to form ferric oxide. OCDD 101 does not need agitation for oxygen removal and can be manufactured easily to withstand centrifugation as part of a blood collection system as necessary.

15 Referring to Figs. 7a through 7c and Figs. 8a through 8c, examples of flushing depletion devices are disclosed. The depletion devices function to deplete, O₂ and CO₂, or O₂ alone, or O₂ with specific levels of CO₂ by supplying appropriate composition of flushing gas. Gases appropriate for depletion devices are, for example, Ar, He, N₂, Ar/CO₂, or N₂/CO₂.

20 Figs. 9a through 9c and 10a through 910c, also disclose scavenging depletion devices. Depletion takes place with the use of scavengers or sorbents and without the use of external gases. In both types of depletion devices however, carbon dioxide depletion in conjunction with oxygen depletion is
25 effective to enhance DPG and ATP, respectively, prior to storage in blood storage bags.

Referring to Figs. 7a through 7c, a depletion device 20 is shown. Depletion device 20 includes a plurality of fibers 25, approximately 5000 in
30 number, through which red blood cells flow. Plurality of fibers 25 are surrounded by a plastic cylinder 30. Plastic cylinder or cartridge 30 contains a

gas inlet 35 and a gas outlet 40 through which a flushing gas or a combination of flushing gases, such as those mentioned above, are supplied to remove carbon and/or oxygen from blood. Specifications for depletion device 20 are shown in Table 1 below at second column.

5

Table 1

Prototype Specification	External Gas Pathways	External Gas Pathways
Prototype Serial #:	Device 20	Device 45
Fiber Type:	Celgard 200/150-66FP I	Celgard 200/150-66F PI
Number of Fibers:	5000	5000
Active Length of Fibers (cm):	13	28
Fiber OD (microns):	200	200
Fiber ID (microns):	150	150
Total Length of Fibers	15	30
Active Fiber Surface Area (m ²):	0.4084	0.8796

Referring to Figs. 8a through 8c, a depletion device 45 is shown. Depletion device 45, like device 20 of Figs. 7a to 7c, includes a plurality of fibers 50, approximately 5000 in number, through which red blood cells flow. Plurality of fibers 50 are surrounded by a plastic cylinder 55. Plastic cylinder 55 contains a gas inlet 60 and a gas outlet 65 through which a gas or a combination of gases, such as those mentioned above are supplied to remove oxygen or oxygen and carbon dioxide from blood. Specifications for depletion device 45 are shown in Table 1 above in the third column. The active surface area of depletion of device 45 is twice that of device 20 because device 45 is twice as long as device 20.

Figs. 9a through 9c disclose a depletion device 70 having a core 75 containing scavenging materials for either O₂, or both O₂ and CO₂. Core 75 is packed by a gas permeable film with very low liquid permeability. Hollow fibers 80 are wound around core 75, and a plastic cylinder 82 contains and envelopes hollow fibers 80. In this particular embodiment, the active surface area for depletion is approximately 0.8796m² as shown in Table 2 below at the second column.

Table 2

Prototype Specification	Center Core 125 grams Sorbent	10 individual Bundles 200 grams Sorbent
Prototype Serial #:	Device 70	Device 85
Fiber Type:	Celgard 200/150-66FPI	Celgard 200/150-66FPI
Number of Fibers:	5000	5000
Active Length of Fibers (cm):	13	28
Fiber OD (microns):	200	200
Fiber ID (microns):	150	150
Total Length of Fibers	15	30
Active Fiber Surface Area (m ²):	0.8796	0.8796

10

Figs. 10a through 10c disclose a depletion device 85 containing fiber bundles 87 enclosed in gas permeable film with very low liquid permeability. Fiber bundles 87 are surrounded by scavenger materials 89 for either O₂ or both O₂ and CO₂. Fiber bundles 87 and scavenger materials 89 are contained within a plastic cylinder 90. The active surface area for depletion is approximately 0.8796m² as shown in Table 2 above at the third column.

15

Fig. 11 is a plot of the performance of flushing depletion devices 20 and 45 and scavenging depletion devices 70 and 85. The data of Fig. 11 was plotted using the following conditions: Hematocrit, 62% (pooled 3 units of pRBC), and 21°C at various head heights to produce different flow rates. Oxygen/carbon
5 dioxide scavenger (Multisorb Technologies, Buffalo, NY) was activated with adding 5% and 12% w/w water vapor for device 79 and device 85, respectively. Data are plotted with flow rate (g RBC suspension per min) vs. pO_2 (mmHg).

In the oxygen/carbon dioxide depletion devices disclosed herein, a
10 plurality of gas permeable films/membranes may be substituted for the plurality of hollow fibers. The films and fibers may be packed in any suitable configuration within the cartridge, such as linear or longitudinal, spiral, or coil, so long as they can receive and convey red blood cells.

15 Fig. 11 shows that lowest oxygen saturation is achieved using devices 45 and 85. Device 45 exhibits a larger active surface area exposed to gases along length of fibers 50. Device 85 also has a long surface area of exposure to scavenging materials. Device 85 has bundles 87 surrounded by scavenging materials 89. The space occupied by scavenging materials 89 between bundles
20 87 promotes dispersion of oxygen and carbon dioxide from red blood cells contained in fiber bundles 87, thus aiding scavenging of oxygen and carbon dioxide from red blood cells.

A further use of the depletion devices is to add back oxygen and or
25 carbon dioxide prior to transfusion by flushing with pure oxygen or air. This use is for special cases, such as massive transfusions, where the capacity of the lung to re-oxygenate transfused blood is not adequate, or sickle cell anemia.

Similarly, depletion devices can be used to obtain intermediate levels or
30 states of depletion of oxygen and carbon dioxide depending needs of the patient

to obtain optimal levels in the transfused blood depending upon the patients needs.

Referring to Fig. 4, a blood storage bag 200 according to a preferred
5 embodiment of the present disclosure is provided. Blood bag 200 has an inner
blood-compatible bag 250 (preferably polyvinyl chloride (PVC)), and an outer
barrier film bag 255. The material of bag 250 is compatible with RBCs.
Disposed between inner bag 250 and outer oxygen barrier film bag 255 is a
pocket that contains an oxygen/carbon dioxide sorbent 110. Barrier film bag
10 255 is laminated to the entire surface of inner bag 250. Sorbent 110 is contained
in a sachet 260, which is alternately referred to as a pouch or pocket. Sorbent
110 is optimally located between tubing 440 that leads into and from bag 200,
specifically between inner bag and outer oxygen barrier film bag 255. This
location will ensure that oxygen disposed between these two bags will be
15 scavenged or absorbed. Oxygen sorbent is ideally located in a pouch or pocket
260 and not in contact with RBCs. Oxygen sorbent may also be combined with
CO₂ scavengers or sorbents, enabling sorbent 110 to deplete both oxygen and
carbon dioxide at the same time.

20 Referring to Figs. 5a and 5b, blood storage bags 201 and 202 are
configured to store RBCs for extended storage periods of time. Inner blood
storage bags 205 are preferably made from DEHP-plasticized PVC and are in
contact with RBCs. DEHP-plasticized PVC is approximately 200 fold less
permeable to oxygen compared to silicone. However, PVC is insufficient as an
25 oxygen barrier to maintain the anaerobic state of RBCs throughout the storage
duration. Therefore, blood storage bags 201 and 202 are fabricated with outer
transparent oxygen barrier film 206 (e.g., nylon polymer) laminated to the outer
surface inner blood bag 205. This approach, as well as one shown in Fig. 3, uses
accepted PVC for blood contact surface (supplying DEHP for cell stabilization)
30 at the same time prevents oxygen entry into the bag during extended storage.

In Fig. 5a, a small sachet 210 containing oxygen/carbon dioxide sorbent 110 enveloped in oxygen-permeable, RBC compatible membrane is enclosed inside of laminated PVC bag 205 and in contact with RBCs. Small sachet envelope 210 is preferably made from a silicone or siloxane material with high oxygen permeability of biocompatible material. Sachet envelope 210 has a wall thickness of less than 0.13 mm thickness ensures that O₂ permeability ceases to become the rate-limiting step. PVC bag 205 may also contain carbon dioxide scavengers.

10 Referring to Fig. 5b, bag 202 has a similar configuration to bag 201 of Fig. 4a. However, bag 202 has a large sorbent 215 enclosed inside of PVC bag 205. Large sorbent 215 preferably has a comb-like configuration to rapidly absorb oxygen during extended storage. The benefit of laminated bags of Figs. 4a and 4b is that once RBCs are anaerobically stored in bags, no further special handling is required. Similarly, bag 202 may contain carbon dioxide scavenger to provide carbon dioxide-scavenging in addition to oxygen-scavenging capability.

20 Referring to the embodiments of Figs. 6a and 6b, RBCs are stored in secondary bags 301 and 302, respectively, in order to maintain an anaerobic storage environment for RBC storage. Secondary bags 301 and 302 are transparent oxygen barrier films (e.g., nylon polymer) that compensate for the inability of PVC blood bags 305 and 320, respectively, to operate as a sufficient oxygen barrier to maintain RBCs in an anaerobic state. Secondary bags 301 and 25 302 are made with an oxygen barrier film, preferably a nylon polymer or other transparent, flexible film with low oxygen permeability.

30 Referring to Fig. 6a, a small oxygen/carbon dioxide sorbent 310 is disposed between a PVC barrier bag 305 and secondary bag 306 to remove slowly diffusing oxygen. Fig. 6a is similar to the preferred embodiment of the blood bag of Fig. 4 except that secondary bag 306 is separate from and not

bonded to bag 305 in this embodiment. PVC bag 305 including ports are enclosed in secondary barrier bag 305. Oxygen sorbent 310 may optionally contain carbon dioxide scavengers to provide both oxygen and carbon dioxide scavenging capability.

5

Referring to Fig. 6b, a secondary bag 302 contains a large sachet 325 inside of PVC bag 320. Sachet 325 is filled with either oxygen or oxygen/carbon dioxide sorbent 110. Sachet 325 is a molded element with surface texture to increase the surface area. Sachet 325 has a comb-like geometry for rapid oxygen or oxygen/carbon dioxide depletion. Sachet 325 acts rapidly to strip oxygen or oxygen/carbon dioxide from RBCs prior to refrigeration and storage of RBCs in place of OCDD of Fig. 3. However, with this configuration, agitation is necessary, therefore sachet 325 must possess a large surface area, high oxygen or oxygen/carbon dioxide permeability and mechanical strength to withstand centrifugation step during component preparation and the prolonged storage. Sachet 325 is preferably made from materials such as 0.15 mm thick silicone membrane with surface texture to increase the surface area. Sachet 325 may be made from materials such as PTFE or other fluoropolymer. Sachet 325 may have a rectangular shape such, such as, for example, a 4" X 6" rectangle, although other sizes are possible, for the anaerobic maintenance. Sachet 325 may contain carbon dioxide scavengers in addition to oxygen scavengers to provide oxygen and carbon dioxide scavenging capability.

25 The embodiments of Figs. 6a and 6b are easily made from off-shelf components except for sachet 325 of Fig. 6b. In order to access RBCs for any testing, secondary bags 301 and 302 must be opened. Unless the unit is transfused within short time, RBC must be re-sealed with fresh sorbent for further storage. (1 day air exposure of storage bag would not oxygenate blood to appreciable degree, since PVC plasticized with DEHP has relatively low permeability to oxygen).

30

In Figs. 5a, 5b, 6a and 6b, the PVC bag is preferably formed with the oxygen barrier film, such as a SiO₂ layer formed with the sol-gel method. A portion of the sheet material will be sealed on standard heat sealing equipment, such as radiofrequency sealers. Materials options may be obtained in extruded sheets and each tested for oxygen barrier, lamination integrity, and seal strength/integrity.

For each of the several embodiments addressed above, an additive solution from bag 300 is provided prior to stripping oxygen and carbon dioxide from the RBCs is used. The additive solution 300 preferably contains the following composition adenine 2mmol/L; glucose 110 mmol/L; mannitol 55 mmol/L; NaCl 26mmol/L; Na₂HPO₄ 12mmol/L citric acid and a pH of 6.5. Additive solution 300 is preferably an acidic additive solution OFAS3, although other similar additive solutions could also be used that are shown to enhance oxygen/carbon dioxide -depleted storage. OFAS3 has shown enhanced ATP levels and good in vivo recovery as disclosed herein. While OFAS3 is a preferred additive solution, other solutions that offer similar functionality could also be used. Alternatively, additive solutions used currently in the field, such as AS1, AS3, AS5, SAGM, and MAPS can also be used. Additive solutions help to prevent rapid deterioration of RBCs during storage and are typically added prior to RBCs being made anaerobic.

Additionally, we envision that the OCDD and storage bags 100 and 200 can be manufactured independent of other components of the disposable, anaerobic blood storage system (i.e., every item upstream of and including leuko reduction filter 400 in Fig. 1a).

It is within the scope of the present disclosure to remove oxygen from the RBCs or to strip oxygen and carbon dioxide from the blood prior to storage in the storage bags. An oxygen scavenger can be used to remove the oxygen

from the RBCs prior to storage in the blood bags. As used herein, "oxygen scavenger" is a material that irreversibly binds to or combines with oxygen under the conditions of use. For example, the oxygen can chemically react with some component of the material and be converted into another compound. Any material where the off-rate of bound oxygen is zero can serve as an oxygen
5 scavenger. Examples of oxygen scavengers include iron powders and organic compounds. The term "oxygen sorbent" may be used interchangeably herein with oxygen scavenger. As used herein, "carbon dioxide scavenger" is a material that irreversibly binds to or combines with carbon dioxide under the
10 conditions of use. For example, the carbon dioxide can chemically react with some component of the material and be converted into another compound. Any material where the off-rate of bound carbon dioxide is zero can serve as a carbon dioxide scavenger. The term "carbon dioxide sorbent" may be used interchangeably herein with carbon dioxide scavenger. For example, oxygen
15 scavengers and carbon dioxide scavengers are provided by Multisorb Technologies (Buffalo, NY) or Mitsubishi Gas Chemical Co (Tokyo, Japan). Oxygen scavengers may exhibit a secondary functionality of carbon dioxide scavenging. Such materials can be blended to a desired ratio to achieve desired results.

20

Carbon dioxide scavengers include metal oxides and metal hydroxides. Metal oxides react with water to produce metal hydroxides. The metal hydroxide reacts with carbon dioxide to form water and a metal carbonate. For example, if calcium oxide is used, the calcium oxide will react with water that is
25 added to the sorbent to produce calcium hydroxide

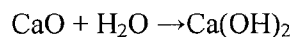

The calcium hydroxide will react with carbon dioxide to form calcium
30 carbonate and water.

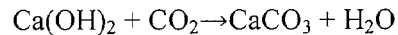

It will be appreciated that scavengers can be incorporated into storage receptacles and bags in any known form, such as in sachets, patches, coatings, pockets, and packets.

5

If oxygen removal is completed prior to introduction of the RBCs to the blood storage device, then it can be accomplished by any method known in the art. For example, a suspension of RBCs can be repeatedly flushed with an inert gas (with or without a defined concentration of carbon dioxide), with or without gentle mixing, until the desired oxygen and or carbon dioxide content is reached
10 or until substantially all of the oxygen and carbon dioxide has been removed. The inert gas can be argon, helium, nitrogen, mixtures thereof, or any other gas that does not bind to the hememoiety of hemoglobin.

The OCDDs and various storage bags of the present disclosure can be used in varying combinations. For example, OCDD 101 of Fig. 3 can be used with blood bag of Fig. 4, 201 of Fig. 5a or 301 of Fig. 6a. When oxygen is depleted by in-bag sachet 215 of Fig. 6b, it can be stored as in Fig. 6b or oxygen/carbon dioxide -depleted content transferred to the final storage bag
20 such as Fig. 4, Fig. 5a or Fig. 6a for extended storage. Other combinations and configurations are fully within the scope of the present disclosure.

The present disclosure also provides another embodiment of a blood storage device. The device is a sealed receptacle adapted to retain and store red
25 blood cells. The receptacle has walls formed from a laminate. The laminate has (a) an outer layer of a material substantially impermeable to oxygen or oxygen and carbon dioxide, (b) an inner layer of a material compatible with red blood cells, and (c) an interstitial layer between the outer layer and the inner layer. The interstitial layer is of a material having admixed therein an amount of an
30 oxygen scavenger or an oxygen/carbon dioxide scavenger. The layers preferably take the form of polymers. A preferred polymer for the outer layer is

nylon. A preferred polymer for inner layer is PVC. The polymer of the interstitial layer should provide effective adhesion between the inner and outer layers and provide effective admixture of oxygen scavengers or oxygen/carbon dioxide scavengers therein. Useful polymers for the interstitial layer include, for example, olefin polymers, such as ethylene and propylene homopolymers and copolymers, and acrylic polymers.

The present disclosure also provides another embodiment of a blood storage system. The system has a collection bag for red blood cells; a unitary device for depleting oxygen or oxygen and carbon dioxide and reducing leukocytes and/or platelets from red blood cells; a storage bag for red blood cells; and tubing connecting the collection bag to the unitary device and the unitary device to the storage bag. A feature of this embodiment is that the functions of depleting oxygen or oxygen and carbon dioxide and reducing leukocytes and/or platelets from red blood cells are combined into a single, unitary device rather than require separate devices. For instance, unitary device can take the form of a single cartridge. Leukocyte and/or platelet reduction is typically carried out by passing red blood cells through a mesh. In this embodiment, a mesh can be incorporated into either the flushing or the scavenging oxygen or oxygen/carbon dioxide depletion device disclosed herein. The mesh is preferably located within the device so that leukocyte and/or platelet reduction takes place prior to the onset of flushing or scavenging.

The following are examples of the present disclosure and are not to be construed as limiting.

EXAMPLES

Figs. 12a through 12h show the results of a 3-arm study showing: a control (aerobic OFAS3 with no O₂ or CO₂ depletion), anaerobic OFAS3 (both O₂ and CO₂ depleted with pure Ar), and O₂ only depleted with 95% Ar and 5% CO₂ (CO₂ is not depleted).

Whole blood was collected into CP2D (Pall), centrifuged 2KxG for 3 minutes, plasma removed, and additive solution AS-3 (Nutricel, Pall), or experimental OFAS3 added. The unit was evenly divided into 3 600mL bags. 2
5 bags were gas exchanged x7 with Ar or Ar/CO₂, transferred to 150 mL PVC bags and stored 1°C to 6°C in anaerobic cylinders with Ar/H₂ or Ar/H₂/CO₂. One control bag was treated in the same manner without a gas exchange and stored 1°C to 6°C in ambient air. Bags were sampled weekly for up to 9 weeks.

10 The plots of Figs. 12a, 12c, 12e and 12g: use the additive solution OFAS3 (200mL; experimental, proprietary) and the plots of Figs 12b, 12d, 12f and 12h, use the AS-3 additive solution. Comparing additive solutions, effects of CO₂ depletion on DPG levels were similar. OFAS3 showed higher ATP when oxygen was depleted (\pm CO₂), and O₂ depletion alone showed significant
15 enhancement of ATP compared to aerobic control. AS-3 additive exhibited no significant enhancement of ATP when O₂ alone was depleted.

Figs. 12a and 12b: DPG levels during storage. DPG levels were maintained for over 2 weeks, when CO₂ was removed in addition to oxygen.

20

Fig. 12c: ATP levels during storage with OFAS3. Highest ATP levels were achieved with OFAS3 RBC when O₂ only was depleted. For O₂/CO₂ depletion, intermediate levels of ATP were observed compared to the control while very high DPG levels were attained during first 2.5 weeks. Very high
25 levels of ATP may suggest higher rate of 24-hour post transfusion recovery. Therefore, extent of carbon dioxide and oxygen depletion levels may be adjusted to meet the specific requirement of the recipient. DPG levels can be maintained very high (at the expense of ATP) for purposes of meeting acute oxygen demand of recipient. Conversely, very high ATP levels may allow
30 higher 24-hour recovery rate (lower fraction of non-viable RBC upon transfusion) thereby reducing the quantity of blood needed to be transfused (up

to 25% of RBC are non-viable). More importantly, this would benefit chronically transfused patients who may not demand highest oxygen transport efficiency immediately after transfusion (DPG level recovers in body after 8-48 hours) who suffers from toxic iron overloading caused by non-viable RBCs.

5

Fig. 12d: ATP levels during storage with AS3. Highest ATP levels were achieved with AS3 RBC when O₂ only was depleted. No significant differences in ATP levels were observed with control and O₂ depletion alone.

10

Figs. 12e and 12f: pH of RBC cytosol (in) and suspending medium (ex). Immediately after gas exchange (day 0), significant rise in pH (in and ex) was observed only when CO₂ was depleted together with O₂. Rapid rates of pH decline observed with CO₂/O₂ depleted samples were caused by higher rates of lactate production (Figs. 12g and 12h).

15

Figs. 12g and 12h: Normalized (to hemoglobin) glucose and lactate levels during storage with OFAS3 and AS3. Higher rates of glucose depletion and lactate productions correspond to high DPG levels observed in panels A and B. Legends for symbols/lines are same for both panels. OFAS3 additive contains similar glucose concentration with x2 volume resulting in higher normalized glucose levels.

20

Figs. 12a and 12c taken together, suggest that extent of increases (compared to control) of ATP and DPG levels may be adjusted by controlling level of CO₂ depletion, when O₂ is depleted. Higher glucose utilization and lactate production were observed with enhanced DPG production (Fig. 12g). This may be also effective with AS3 additive, since similar trend in glucose utilization and lactate production were observed (Fig. 12h).

25

Fig. 13 shows a graph comparing the effect of gamma irradiation on aerobic and anaerobic RBC. Fig. 13 shows an control unit, RBC that are

30

aerobic and not gamma-irradiated (Unit A, black filled solid line), aerobic RBC that are gamma-irradiated (Unit B; control plus gamma irradiation indicated by a filled circle with dotted line) and an anaerobically depleted RBC unit that has been gamma-irradiated (Unit C; Anaerobic + γ , open circle and solid line). Unit
5 B and Unit C are irradiated and Unit A is non-irradiated and aerobic RBC. The constituent of the blood that is being measured is potassium. The amount of leakage of potassium (K⁺) from RBC that is measured in the storage media is an indicator of health of the RBC. Therefore, in the context of the present application, a greater level of concentration of potassium in RBC storage media,
10 is indicative of a greater level of RBC damage relative to a lower level of concentration of potassium in RBC storage media.

Fig. 13 indicates that gamma irradiation induced a high rate of K⁺ leakage during the first week for Unit B and Unit C. K⁺ leakage rates after days
15 eight and fifteen, were similar for all units. Significantly, the difference between K⁺ leakage between Unit B and Unit C increases beyond the twenty-second day of storage. The results indicate that this trend could exist for several more days. Accordingly, the use of anaerobic depletion and gamma irradiation may permit the extension of current FDA storage limit of
20 twenty-eight days for anaerobically depleted and gamma irradiated blood prepared after component separation.

Irradiating RBC for immuno-compromised individuals is a necessity. The present results show that irradiated RBC that were also oxygen depleted did
25 not increase K⁺ leakage rates, an indicator of RBC damage. The benefits of oxygen depleted RBC including increased levels of ATP and DPG-2,3 are not negatively impacted by the irradiation.

In graph above, four ABO Rh identical units (in AS3 additive,
30 leukoreduced; standard RBC concentrate obtained from American Red Cross) are pooled. The three units were used for above-graphed experiment from the

pooled unit after it was sub-divided into 4 fractions within 24 hours of blood collection and stored at 1-6 °C.

Although the present disclosure describes in detail certain embodiments,
5 it is understood that variations and modifications known to those skilled in the art that are within the disclosure. Accordingly, the present disclosure is intended to encompass all such alternatives, modifications and variations that are within the scope of the disclosure as set forth in the disclosure.

10

CLAIMS:

1. A blood storage system for preparing irradiated red blood cells comprising:
a collection vessel for red blood cells;
5 an oxygen or oxygen and carbon dioxide depletion device;
a storage vessel for storing oxygen or oxygen and carbon dioxide-depleted red blood
cells under anaerobic conditions;
a first tubing connecting the collection vessel to the oxygen or oxygen and carbon
dioxide depletion device; and
10 a second tubing connecting the oxygen or oxygen and carbon dioxide depletion device
to the storage vessel;
wherein said oxygen or oxygen and carbon dioxide-depleted red blood cells are
capable of being irradiated with a gamma or X-ray irradiating device, when stored in said
storage vessel, and
15 wherein irradiation damage to said oxygen or oxygen and carbon dioxide-
depleted red blood cells is reduced without the addition of L-carnitine or an alkanoul
derivative to said blood storage system.
2. The blood storage system according to claim 1, wherein said anaerobic conditions is
20 measured as an oxygen-saturation of hemoglobin of less than 20% SO₂.
3. The blood storage system according to claim 2, wherein said oxygen-saturation of
hemoglobin is less than 5%.
- 25 4. The blood storage system according to claim 3, wherein said oxygen-saturation of
hemoglobin is less than 3%.
5. The blood storage system according to claim 1, wherein the oxygen or oxygen and
carbon dioxide depletion device comprises:
30 a cartridge;

a plurality of hollow fibers or gas-permeable films extending within the cartridge from an entrance to an exit thereof, wherein the hollow fibers or gas-permeable films are adapted to receiving and conveying red blood cells; and either an oxygen scavenger or an oxygen scavenger and a carbon dioxide scavenger packed within the cartridge and contiguous to and
5 in between the plurality of hollow fibers.

6. The blood storage system according to claim 1, further comprising a leuko reduction filter disposed between said collection vessel and said oxygen or oxygen and carbon dioxide depletion device.
10

7. The blood storage system according to claim 1, further comprising an additive solution vessel in communication with said collection vessel.

8. The blood storage system according to claim 1, further comprising a plasma vessel in
15 communication with said collection vessel.

9. A method for reducing radiation damage in red blood cells, said method comprising:
removing oxygen or oxygen and carbon dioxide from red blood cells, thereby
producing oxygen- or oxygen and carbon dioxide-depleted red blood cells; and
20 irradiating said oxygen- or oxygen and carbon dioxide-depleted red blood cells via
either gamma or X-ray irradiation in the absence of L-carnitine, thereby producing irradiated
oxygen- or oxygen and carbon dioxide-depleted red blood cells.

10. The method according to claim 9, wherein said oxygen- or oxygen and carbon dioxide-
25 depleted red blood cells exhibits an oxygen-saturation of hemoglobin of less than 20% SO_2 .

11. The method according to claim 10, wherein said oxygen saturation of hemoglobin is
less than 5%.

30 12. The method according to claim 11, wherein said oxygen-saturation of hemoglobin is
less than 3%.

13. The method according to claim 9, wherein the oxygen or oxygen and carbon dioxide is removed via an oxygen or oxygen and carbon dioxide depletion device which comprises:
- a cartridge;
 - a plurality of hollow fibers or gas-permeable films extending within the cartridge from an entrance to an exit thereof, wherein the hollow fibers or gas-permeable films are adapted to receiving and conveying red blood cells; and
 - an amount of both an oxygen scavenger or an oxygen and a carbon dioxide scavenger packed within the cartridge and contiguous to and in between the plurality of hollow fibers.
14. The method according to claim 9, further comprising: leuko reduction filtering prior to the step of removing oxygen/carbon dioxide from said red blood cells.
15. The method according to claim 9, further comprising: treating said red blood cells with an additive solution prior to the step of removing oxygen or oxygen and carbon dioxide from said red blood cells.
16. The method according to claim 9, wherein said irradiated anaerobic red blood cells are stored at a temperature from between 1°C to about 6°C under anaerobic conditions.
17. A method for storing red blood cells, said method comprising:
- removing oxygen or oxygen and carbon dioxide from said red blood cells, thereby producing anaerobic red blood cell;
 - irradiating red blood cells via either gamma or X-ray irradiation, thereby producing irradiated anaerobic red blood cells; and
 - storing said irradiated anaerobic red blood cells under anaerobic conditions that do not include L-carnitine or an alkanaoul derivative.
18. The method according to claim 17, wherein said anaerobic red blood cells exhibits an oxygen-saturation of hemoglobin of less than 20% SO₂.

19. The method according to claim 18, wherein said oxygen saturation of hemoglobin is less than 5%.
20. The method according to claim 19, wherein said oxygen-saturation of hemoglobin is less than 3%.
21. The blood storage system according to claim 1, wherein said anaerobic condition is measured as a partial pressure of oxygen (PO_2) of less than 0.08 mmHg.
22. The blood storage system according to claim 1, wherein the oxygen or oxygen and carbon dioxide depletion device is disposable.
23. The method according to claim 9, further comprising storing said irradiated oxygen- or oxygen and carbon dioxide-depleted red blood cells.
24. The method according to claim 9, wherein said oxygen- or oxygen and carbon dioxide-depleted red blood cells are stored prior to said irradiation.
25. The method according to claim 9, wherein said oxygen- or oxygen and carbon dioxide-depleted red blood cells are stored after said irradiation.
26. A composition comprising:
irradiated oxygen or oxygen and carbon dioxide depleted red blood cells,
wherein said oxygen depleted red blood cells comprise an oxygen-saturation of hemoglobin (SO_2) level of less than 20% and said oxygen and carbon dioxide depleted red blood cells comprise an oxygen-saturation of hemoglobin (SO_2) level of less than 20% and a partial pressure of carbon dioxide (pCO_2) of less than 10 mmHg.
27. The composition according to claim 26, wherein said oxygen-saturation of hemoglobin (SO_2) is less than 5%.

28. The composition according to claim 27, wherein said oxygen-saturation of hemoglobin (SO₂) is less than 3%.
29. The composition according to claim 26, wherein said partial pressure of carbon dioxide (pCO₂) is less than 5 mmHg.
30. The composition according to claim 29, wherein said partial pressure of carbon dioxide (pCO₂) is less than 1 mmHg.
31. The composition according to claim 26, wherein said irradiated oxygen depleted or irradiated oxygen and carbon dioxide depleted red blood cells further comprise reduced leukocytes relative to an untreated blood sample.
32. The composition according to claim 26, wherein said irradiated oxygen depleted or irradiated oxygen and carbon dioxide depleted red blood cells further comprise an absorbed dose of radiation of between 25 Gray (Gy) to 50 Gy.
33. The composition according to claim 26, wherein said irradiated oxygen depleted or irradiated oxygen and carbon dioxide depleted red blood cells further comprise an acidic additive solution.
34. The composition according to claim 26, wherein said irradiated oxygen depleted or irradiated oxygen and carbon dioxide depleted red blood cells further comprise an additive solution selected from the group consisting of OFAS3, AS1, AS3, AS5, SAGM, and MAPS.

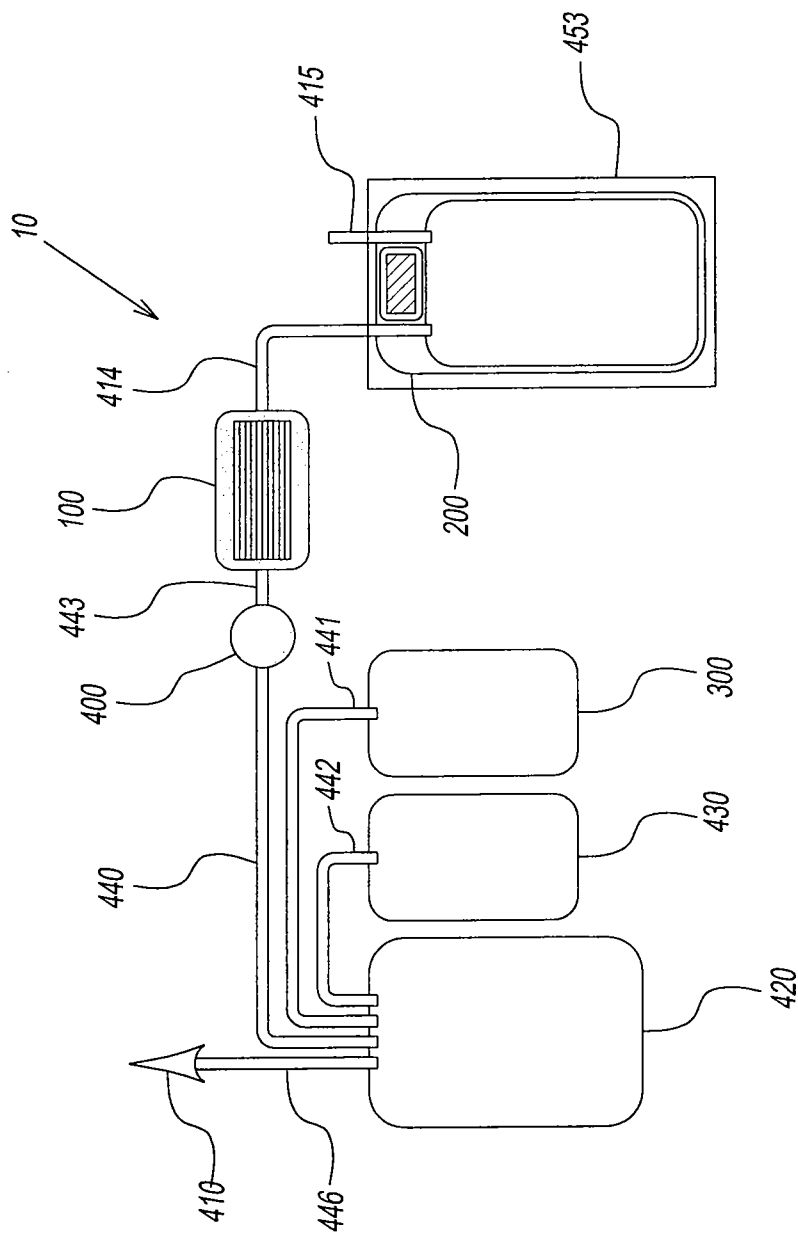

FIG. 1A

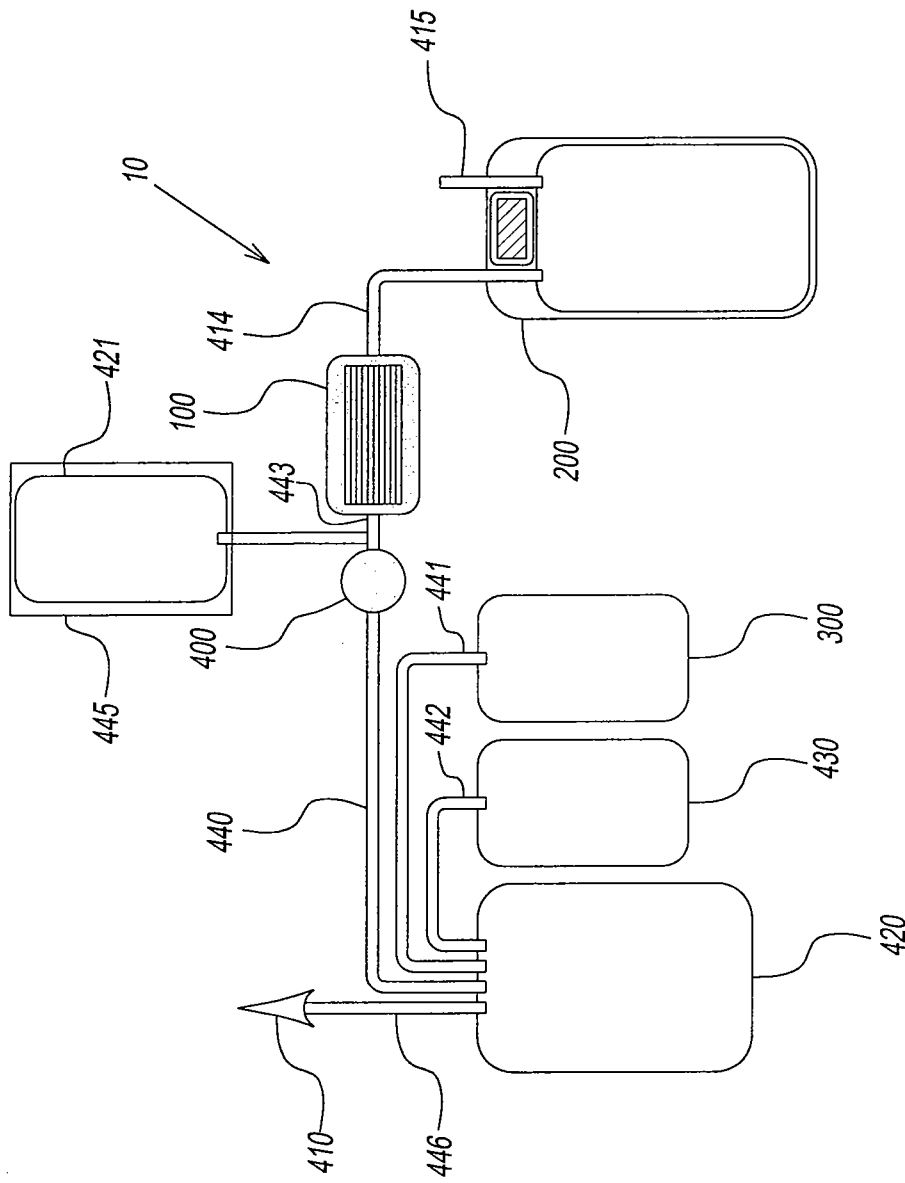

FIG. 1B

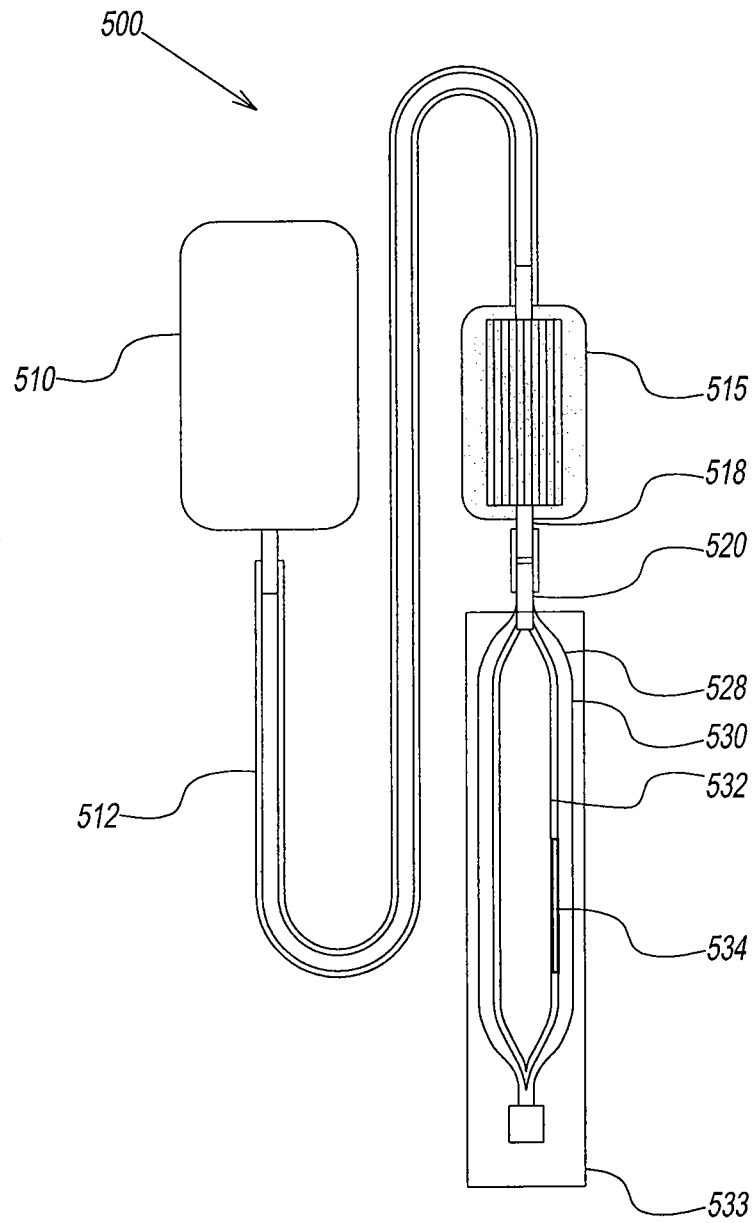

FIG. 2A

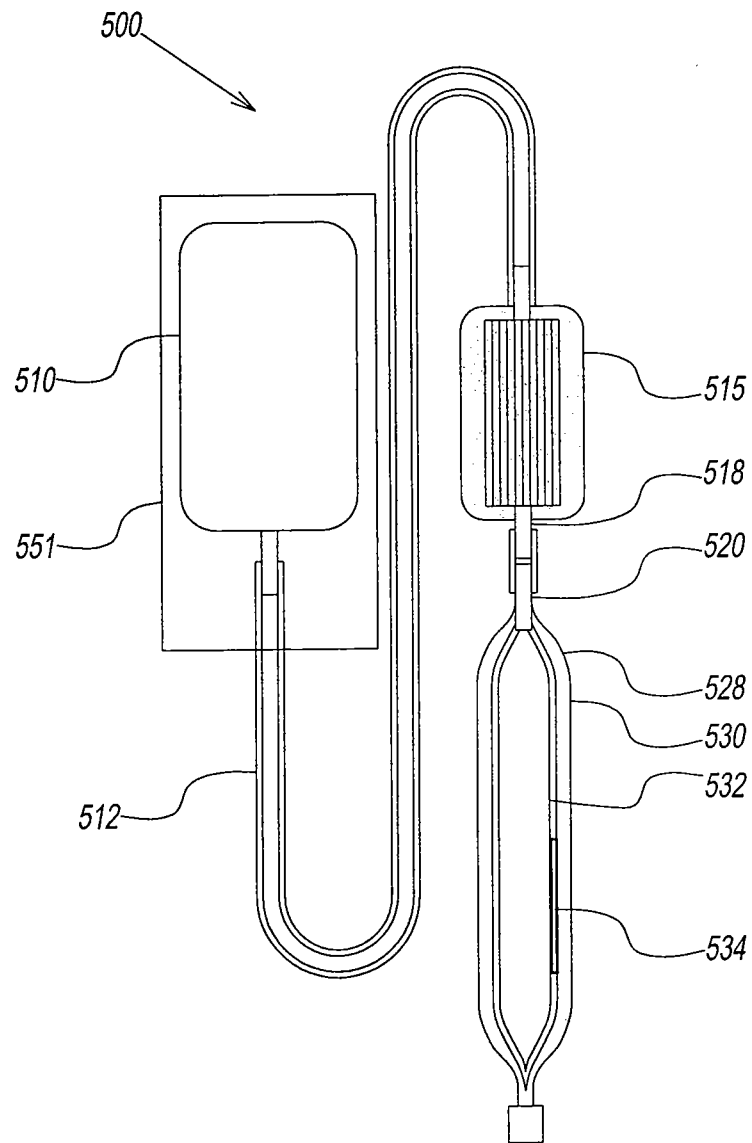

FIG. 2B

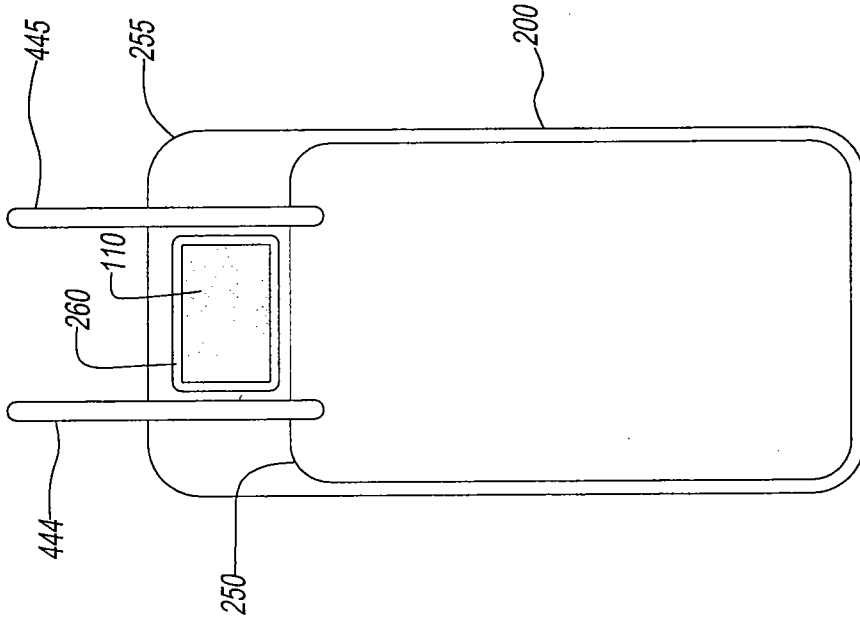

FIG. 4

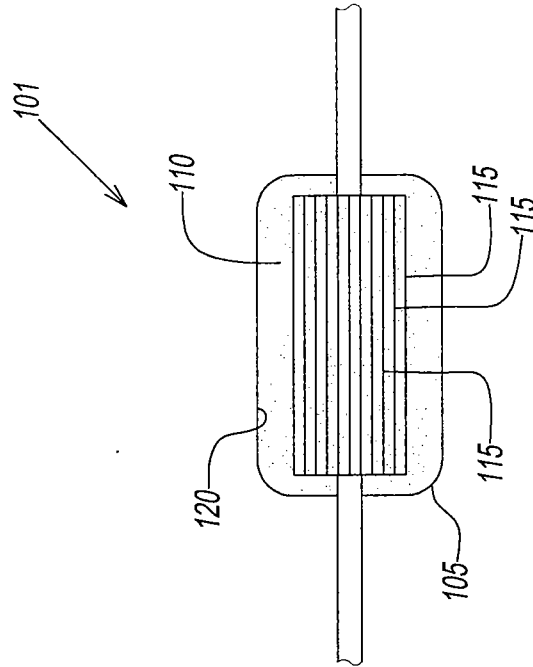

FIG. 3

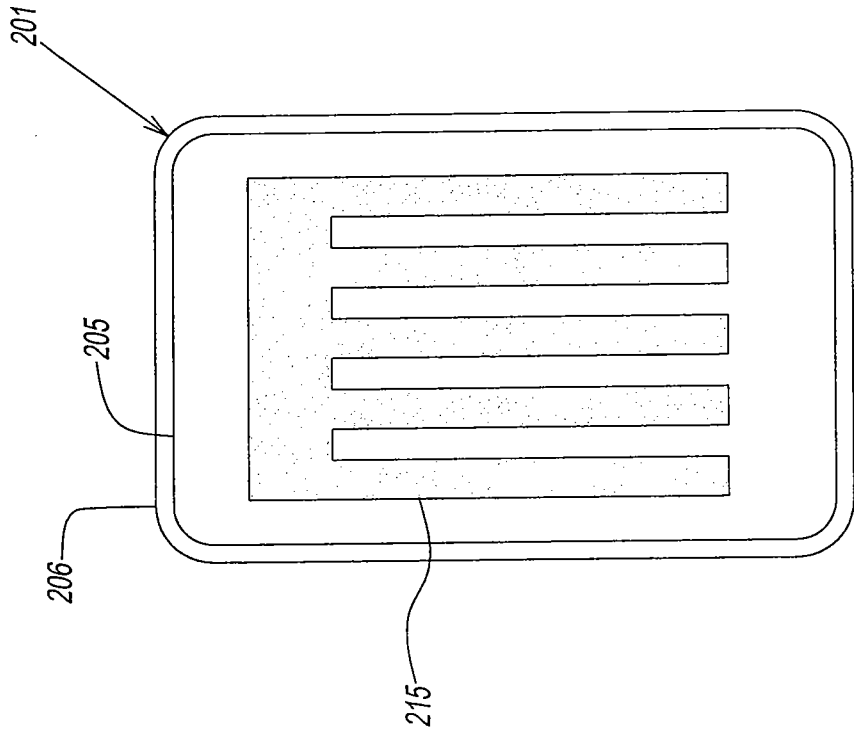

FIG. 5B

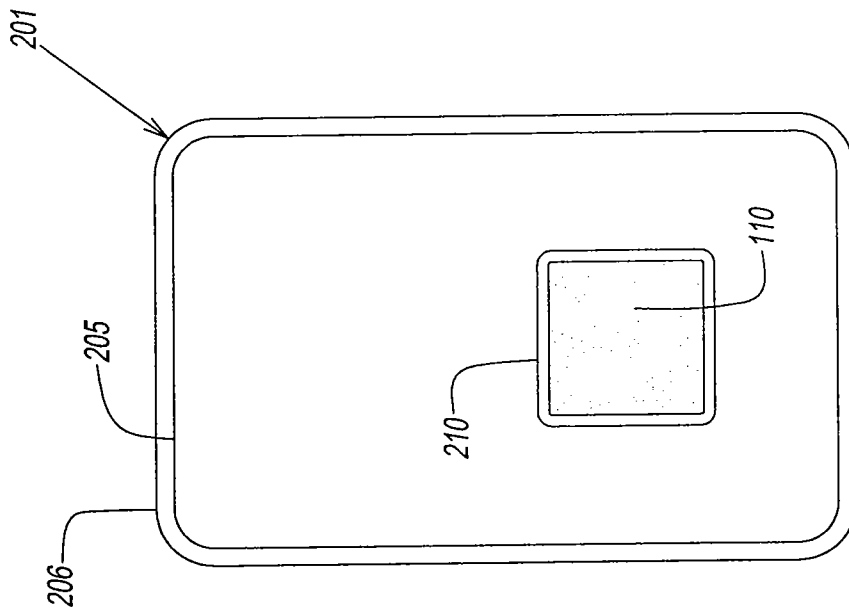

FIG. 5A

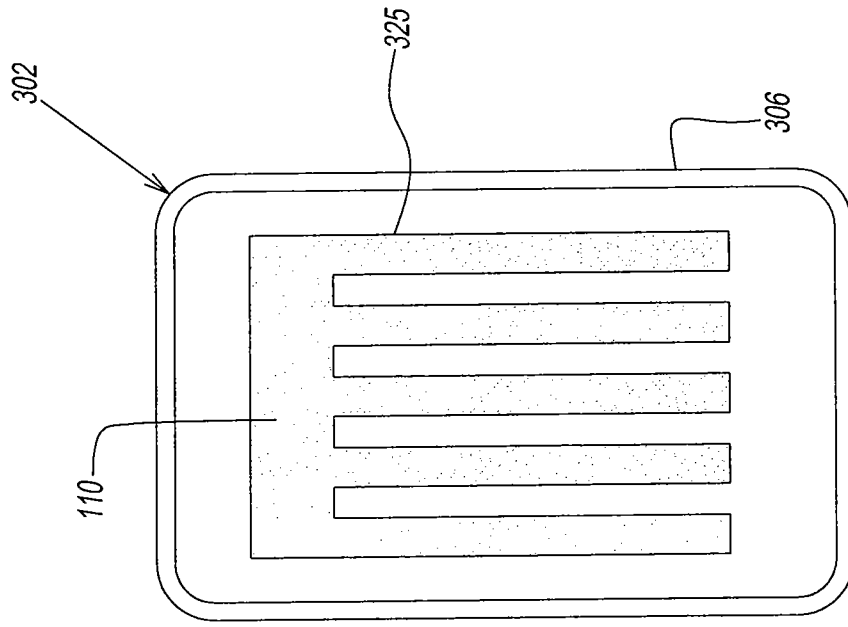

FIG. 6B

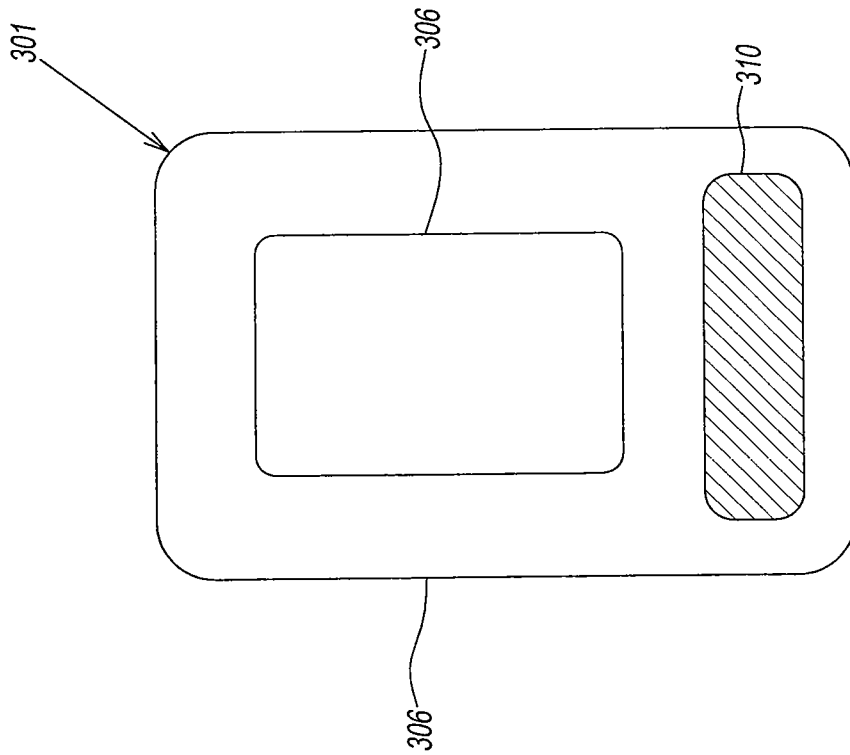

FIG. 6A

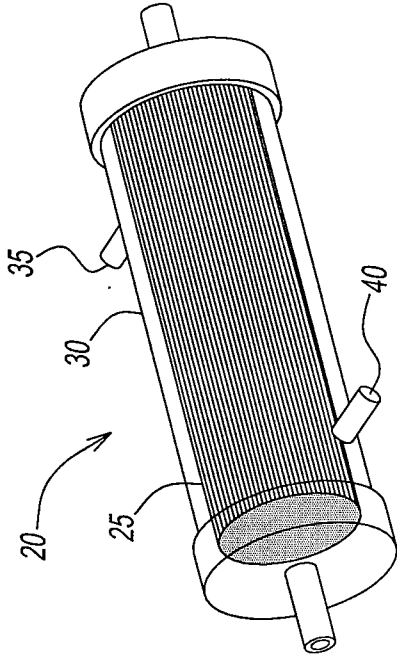

FIG. 7B

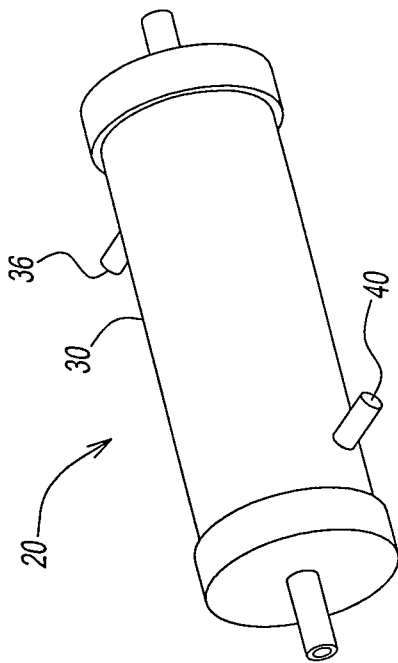

FIG. 7A

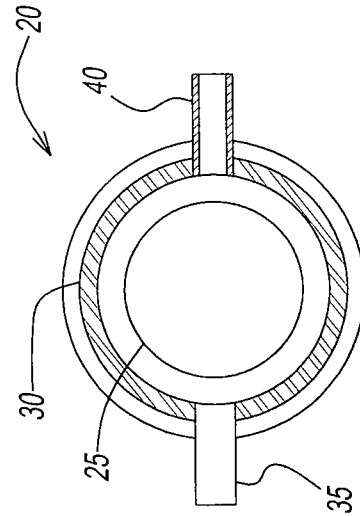

FIG. 7C

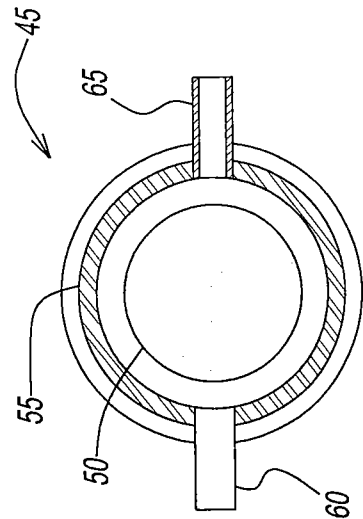
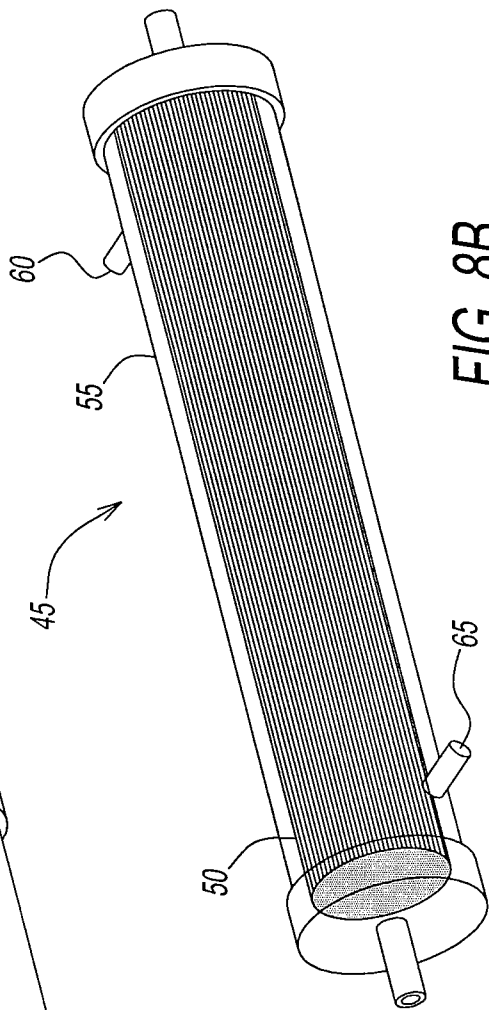
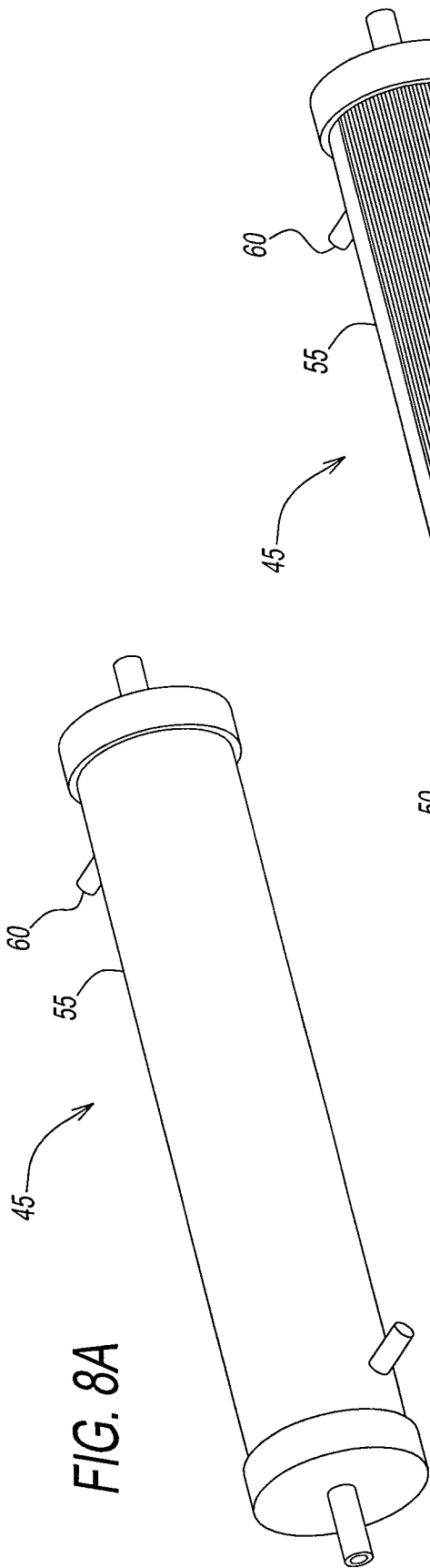
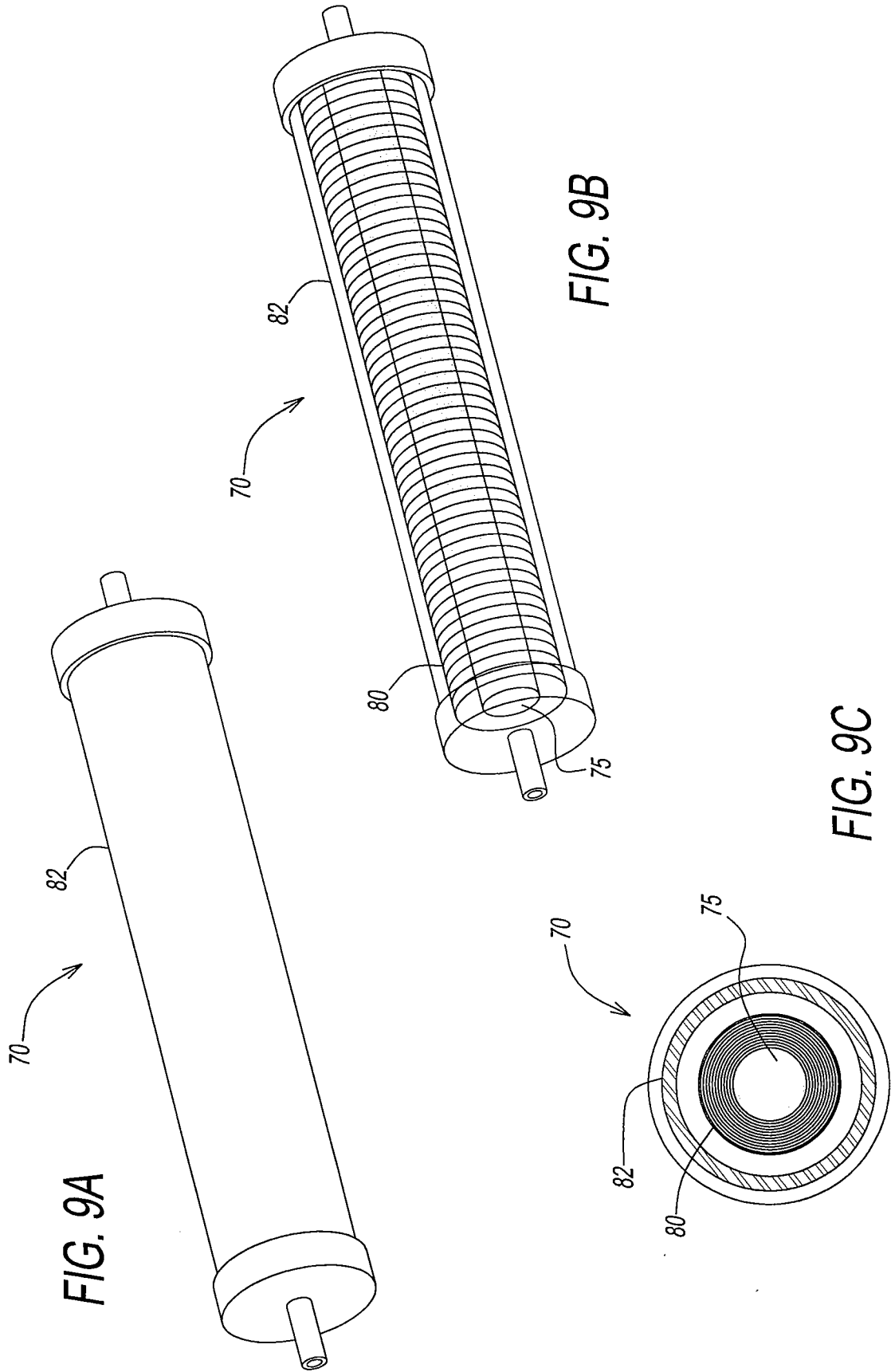
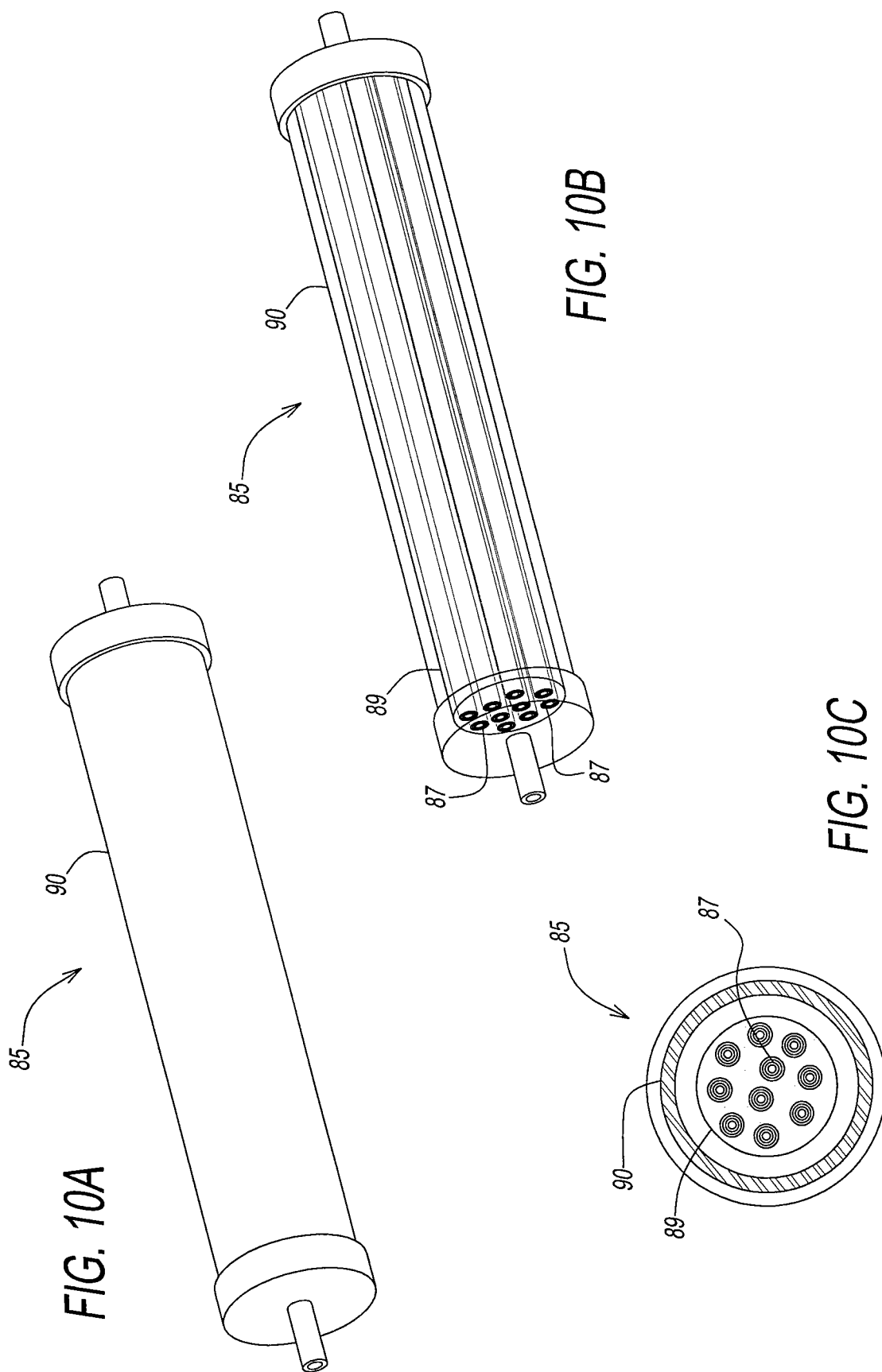

FIG. 8A

FIG. 8B

FIG. 8C





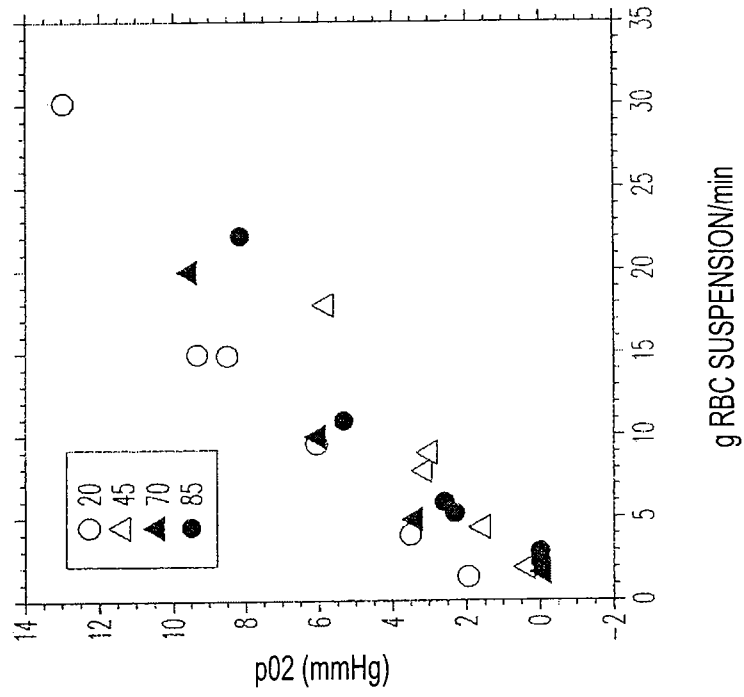

FIG. 11

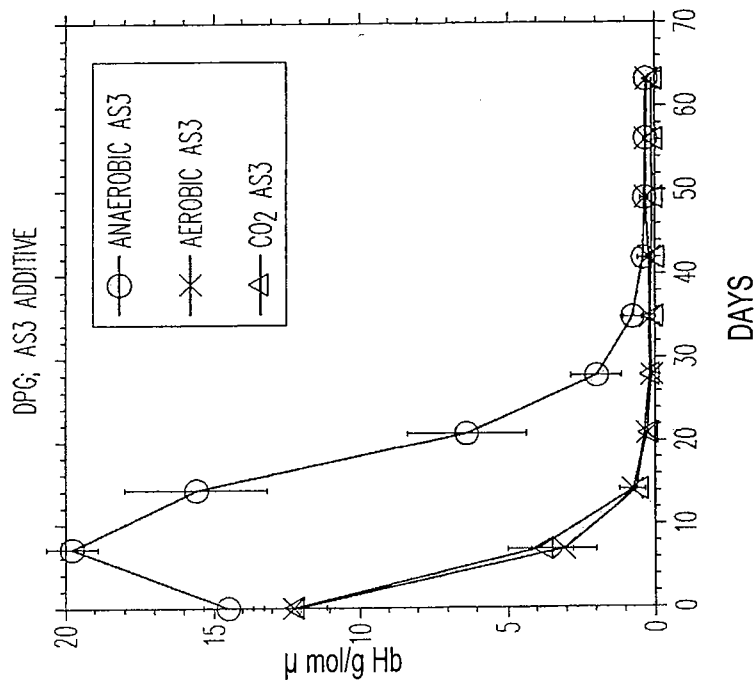

FIG. 12B

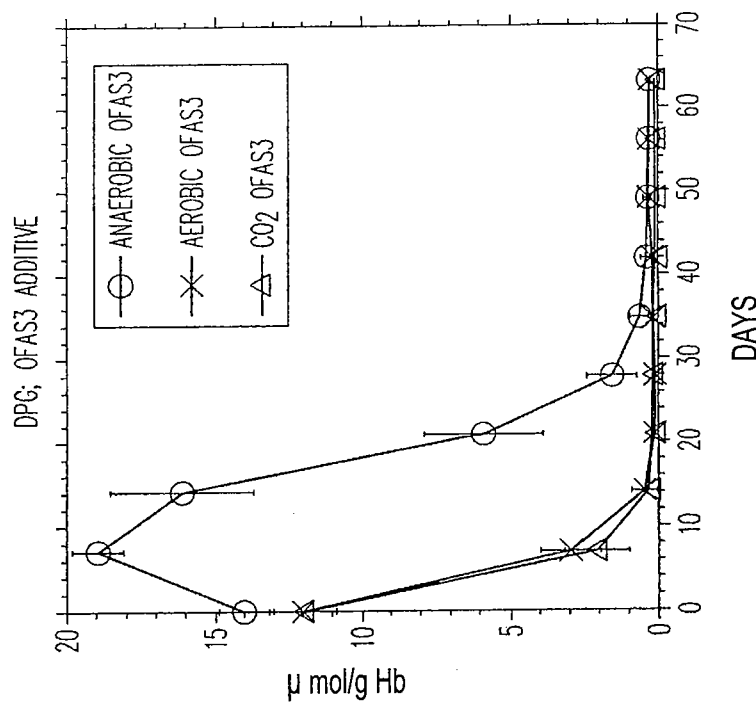

FIG. 12A

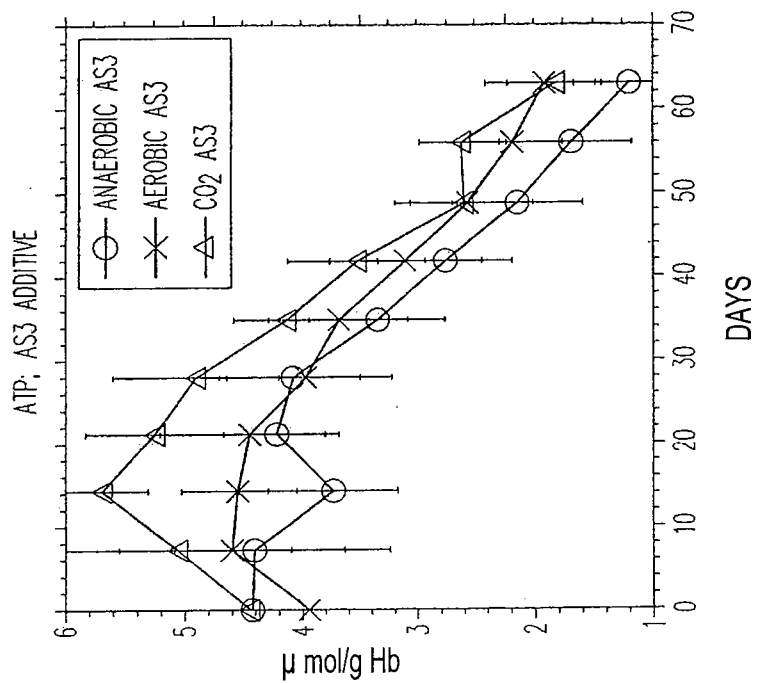

FIG. 12D

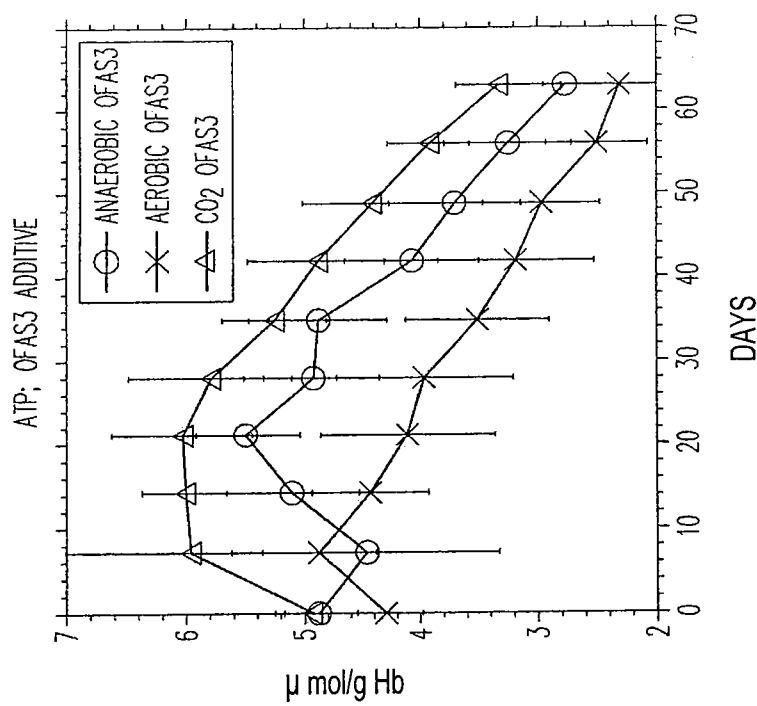

FIG. 12C

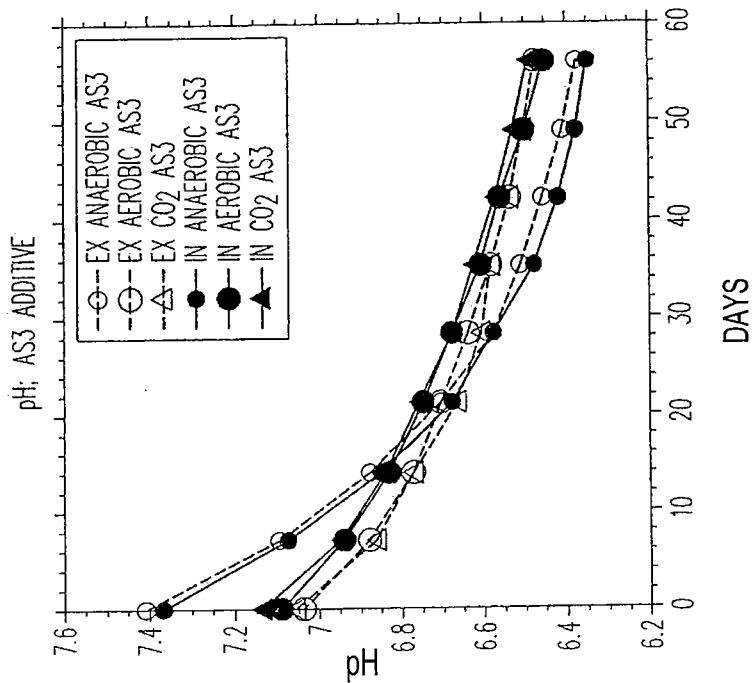

FIG. 12F

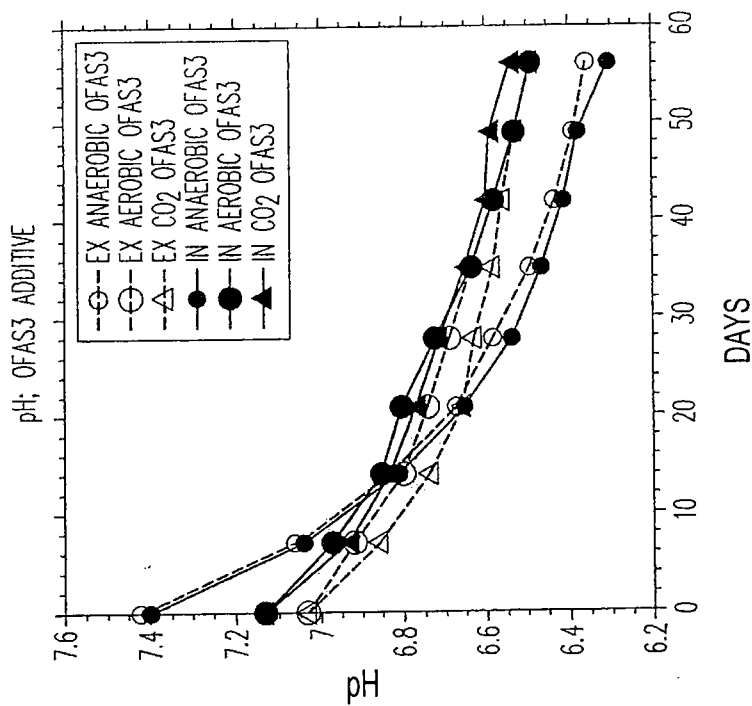

FIG. 12E

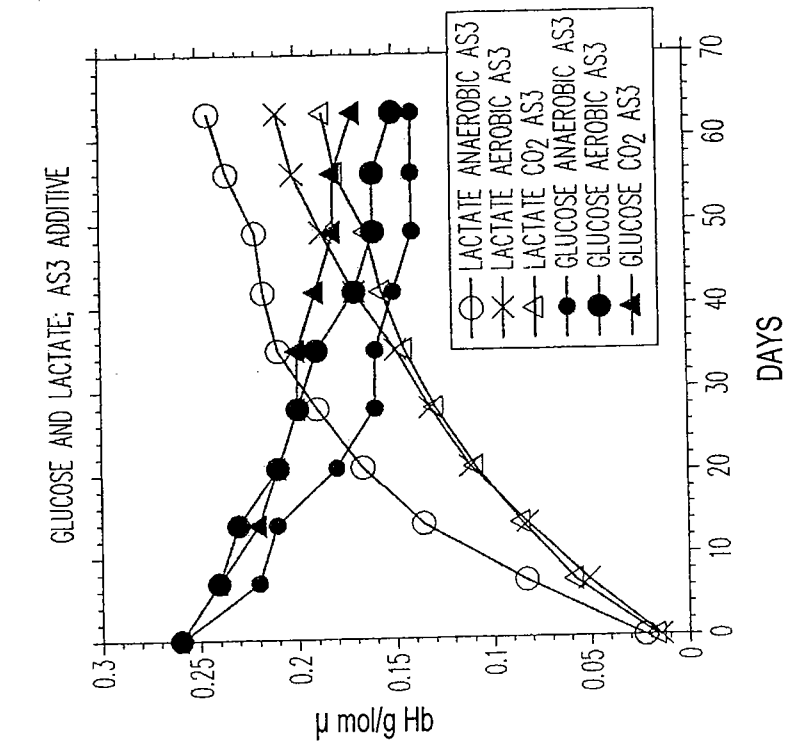

FIG. 12H

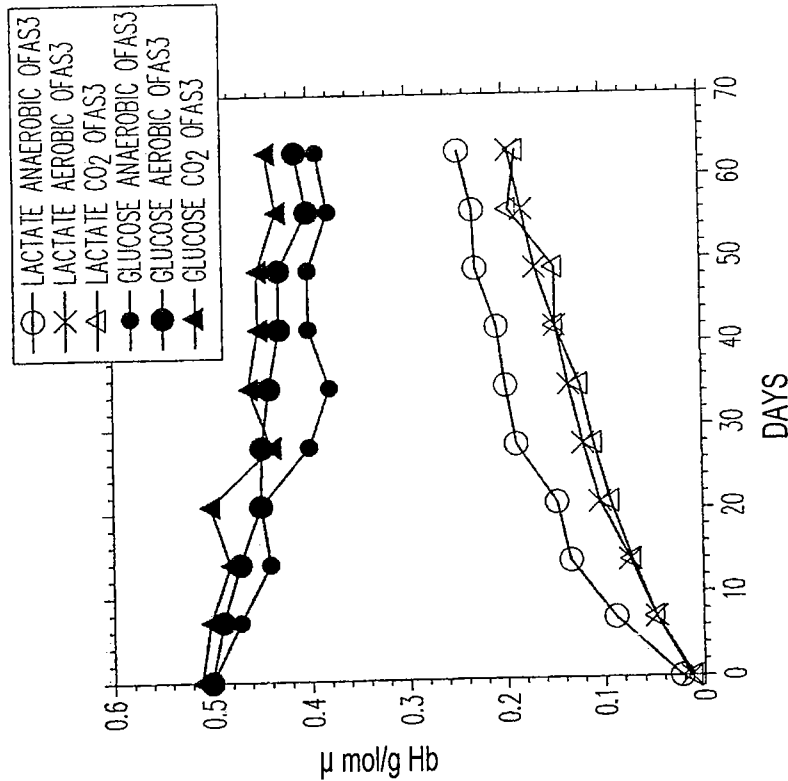

FIG. 12G

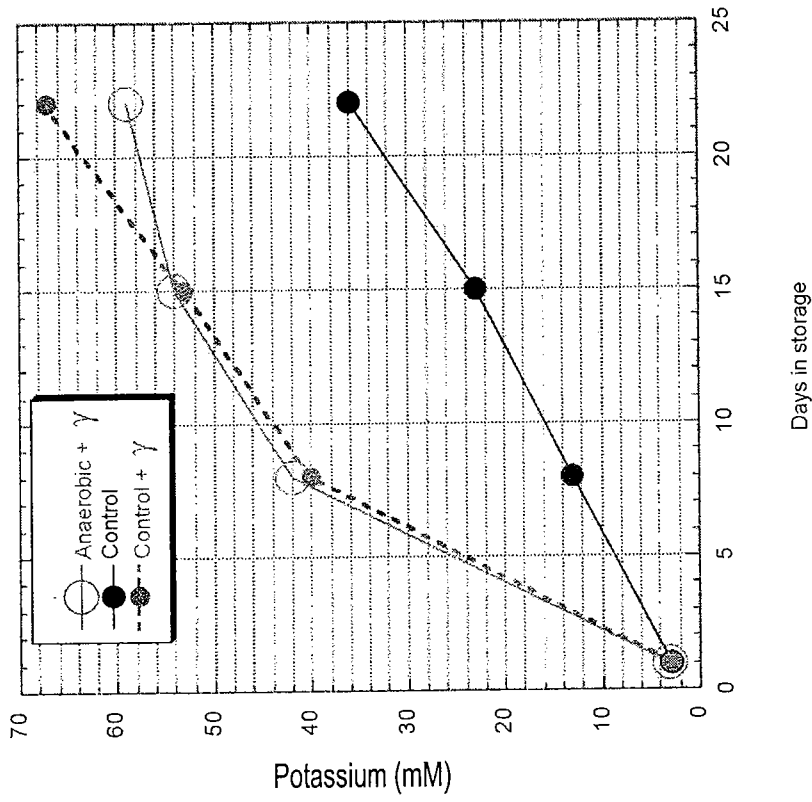

FIG. 13

