

April 10, 1951

M. H. FRENCH
ELECTRIC SWITCH

2,548,103

Filed Nov. 27, 1948

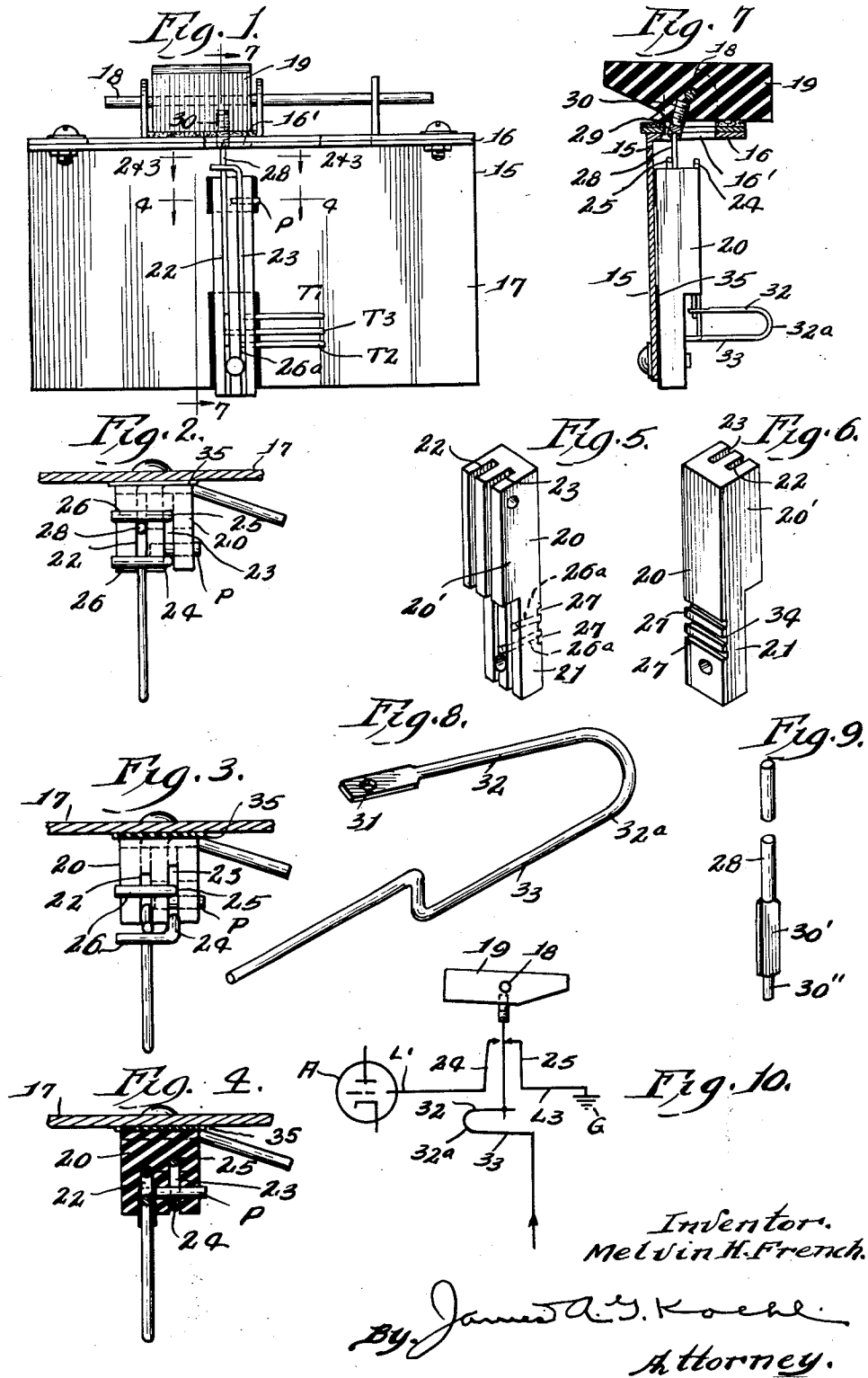

UNITED STATES PATENT OFFICE

2,548,103

ELECTRIC SWITCH

Melvin H. French, Brookfield, Ill., assignor, by
mesne assignments, to Central Commercial In-
dustries, Inc., Chicago, Ill., a corporation of
Delaware

Application November 27, 1948, Serial No. 62,278

3 Claims. (Cl. 200—166)

1

This invention relates to electric switches and actuating mechanism therefor and has for its primary purpose the provision of a simple, inexpensive and positively acting switch for use in the keying circuit of a signal transmission network.

Other objects of the invention will be manifest upon reference to the following description and drawings in which:

Figure 1 is a view in rear elevation of the composite organization;

Figure 2 is a transverse section on line 2—2 of Figure 1 showing the switch in an "off" position;

Figure 3 is a view similar to Figure 2, showing the switch in an "on" position.

Figure 4 is a transverse section on line 4—4 of Figure 1 showing the means for electrically insulating the contact elements from each other;

Figure 5 is a perspective view of the mounting block;

Figure 6 is a view of the mounting block looking in the direction of the surface thereof which is secured to the inner face of the vertical flange of the angle member;

Figure 7 is a vertical section on line 7—7 of Figure 1 taken in a plane which discloses the contactor and its coactive relationship to the contact elements;

Figure 8 is a perspective view of the U-shaped resilient means for constantly applying a yielding force to the actuator for the purpose of urging the contactor against one of the contact elements;

Figure 9 is a perspective view of the contactor; and

Figure 10 is a schematic view of the switch showing the manner of connecting same in a signal transmission circuit.

In carrying the invention into practice, use is made of an angle bar 15 having a horizontally disposed short flange 16 and a vertically disposed long flange 17. Mounted on flange 16 for rocking motion about a horizontal axis 18 is an actuator 19.

Secured to the inner face of the vertical flange 17 of said angle bar and in vertical alinement with a hole 16' in flange 16, is a vertically disposed rectangular block 20 of electrically non-conductive material such as Bakelite, wood or other well known material, which said block has an upper portion 20', of greater thickness than the depending portion 21 of said block. Formed in the block are parallel slots 22 and 23, in the latter of which are spaced apart contact elements 24 and 25, each consisting of a single length of

2

wire such as Phosphor bronze, the upper end of which is provided with a horizontally disposed effective contact portion 26. These portions 26 of elements 24 and 25 are situated at the upper end of the block 20 and extend transversely of slot 22. The lower ends of these contact elements are secured to the block by passing same through complementary apertures 26a in the block, thence into complementary grooves 27 from which they are exposed to provide terminals T₁ and T₂ adapted to be connected in a signal transmission network.

Mounted for to and fro motion in slot 22 and passing through hole 16' is a contactor 28 consisting of a single straight length of Phosphor bronze wire, the upper end of which is received in the cup 29 in the lower end of a threaded stud 30, the latter secured to the under side of the actuator and disposed at an acute angle to the axis of rotation of the actuator. The lower end of the contactor is flattened at 30, and formed with a restricted stud 30'' which is freely extended through a hole 31 in the upper leg 32 of a U-shaped member 32a of Phosphor bronze wire, the lower leg 33 of which is secured to the depending portion 21 of block 22, said portion being extended through a complementary groove 34 from which it extends to provide a terminal T₃ for connection in said transmission network.

An insulating strip 35 is interposed between the inner face of the long flange of angle bar 15 and the grooves 27, 27 and 34 which accommodate the aforementioned terminals T₁, T₂ and T₃ so as to electrically insulate said terminals from said angle bar.

At this point in the description, it follows that by virtue of the resiliency of the U-shaped member 32a, the upper leg 32 thereof tends normally to spring or slide slightly in an upward direction, said member 32a, in coaction with contactor 28 and stud 30 providing a toggle joint in which the contactor tends to spring laterally relative to a vertical line drawn through the pivotal axis of said actuator 19 such that when the actuator is in one possible position of adjustment, it will be maintained in that position until manual pressure is applied thereto to shift same to its other possible position.

In Figure 10 the U-shaped member 32a is connected to the input lead of a single transmission network. Contact element 24 is connected to the output lead L₁ of said network. Contact element 25 is connected to ground G through lead L₂. Lead L₁ is connected to the grid circuit of a vacuum tube amplifier A such that when the

actuator 19 is moved from a substantially horizontal "off" or grounded position to a downwardly and forwardly inclined position, contactor 28 will spring away from and disengage contact element 25 and engage contact element 24, whereupon signal voltage will be conducted to output lead L₁ for activation of amplifier A.

I particularly stress the new and novel features of my invention which consist of two contact elements 24 and 25 between which contactor 28 is mounted for to and fro motion, which contactor is mounted for toggle action and has always applied thereto a resilient force through the medium of the U-shaped member 32a, the contactor and said member 32a forming for all intents and purposes a continuous electrical conductor through which voltage from any source of supply can be selectively impressed upon an output circuit.

While the invention is particularly applicable to musical instruments for conduction of audio signals from tone signal sources to an electro-acoustical translating system, the invention obviously is adapted to be used in any keying circuit as a simple and entirely dependable "off-on" switch.

Contact elements 24 and 25 tend normally by their inherent resiliency to move towards each other and in the direction of a pin P of electrical insulating material which is passed into the upper portion of block 20 and across groove 23 in which both of said elements are mounted. When the actuator is in a grounded or "off" position, contact element 25 is disengaged from said pin by resilient force applied thereto by contactor 28. When tilting the actuator 19 to an "on" position, element 24 is collected by the contactor and moved off of said pin, at which time, contact element 25 by its inherent resiliency moves against said pin. In this manner the contact elements never engage each other and are always electrically insulated from each other.

When the device is used with an electronic musical instrument, such, for example, as the instrument disclosed in Letters Patent, No. 2,250,065 issued July 22, 1948 to James A. Koehl, a plurality of identical switches will be employed to form a common assembly, each separate switch of said assembly functioning in the manner of an organ stop and connected with wave filters, tone generators and a translating device, whereby upon close circuiting a selected switch frequencies from one or more generators will be converted into audible sounds. A switch formed and constructed as disclosed herein in addition to being positively acting, may be disposed in convenient reach of the player and quickly actuated with little or no manual exertion, and by reason of compactness of the organization, same can be attached to a piano in front of the keyboard without interfering with the hands or legs of a player.

Reference in the hereto annexed claims to a contactor mounted for to and fro motion between contact elements of a pair of such elements shall be construed to mean that the effective spaced apart contact portions 26 of said contact elements traverse the groove which accommodates said contactor and that said contactor is disposed in the space between said portions and is always engaged with one of them, such that when the actuator is in an "off" position, the switch is completely grounded and that when same is

in an "on" position the connection to ground is broken, whereby the current flow is to amplifier A via said contactor 28 and contact element 24.

What I claim as my invention, is:

1. An electric switch comprising a pair of resilient contact elements electrically insulated from each other, a pivotally mounted, manually adjustable actuator; a contactor mounted for to and fro motion between said elements and for slight longitudinal motion and connected at one of its ends with said actuator to enable engagement of said contactor with one of said elements in response to motion of said actuator in one direction and to disengage same and engage the other element in response to motion of said actuator in an opposite direction, said contactor comprising a straight length of wire, and means coactive with said contactor for continuously exerting a yielding force against said contactor tending to rock same to one of its positions and engage one of said elements, said means comprising a U-shaped resilient member having a fixedly supported leg and a leg which is yieldable relative thereto and with which the other end of said contactor is operatively connected.

2. An electric switch comprising a substantially rectangular block of electrical insulating material having a pair of longitudinal grooves formed therein and disposed in parallel relation and opening respectively onto one face and at least one end of said block, a pair of contact wires mounted in one of said grooves for to and fro motion relative to each other and having angular extremities extending across the other groove at one end of said block, a contactor in the other groove and comprising a straight length of wire and a pivotally supported actuator coactive with said wire for imparting slight longitudinal motion thereto; one end of which wire is disposed between said angular extremities for selective engagement with any one thereof, and means for electrically insulating said contact elements from each other, said contact wires and said contactor each having a free end firmly secured to said block and disposed exteriorly thereof for connection with respective terminals of an electrical circuit.

3. An electric switch comprising a member of insulating material having two rectilinear grooves in parallel relation, two contact elements spaced apart from each other and mounted for relative motion in one of said grooves and respectively having continuations extending across one end of the other groove, a contactor mounted in said other groove for to and fro motion and circuit controlling engagement thereof first with one and then the other of the continuations of said contact elements, and a pin of electrical insulating material inserted in said member and extending across said one groove and between said contact elements to prevent engagement of said elements with each other.

MELVIN H. FRENCH.

REFERENCES CITED

The following references are of record in the file of this patent:

UNITED STATES PATENTS

Number	Name	Date
2,237,705	Kohl	Apr. 8, 1941
2,314,465	Shaw	Mar. 23, 1943