

Cavity Resonator Device with a Coupling Element

Field of the invention

- 5 The invention relates to a cavity resonator device comprising a coupling element for coupling two adjacent cavity resonators for radio frequency (RF) signals.

Background

Filters for RF signals, e.g. bandpass filters, may be constructed of a plurality of resonators that are coupled (or cross-coupled) by coupling elements. The overall
10 transfer function of the filter is created by the combination of the individual transfer functions of the resonators and the coupling elements. For example, a cavity filter may be implemented as a plurality of interconnected cavity resonators, forming a cavity resonator device. Cavity resonators produce relatively low surface current densities and consequently have relatively high Q-factors. Other resonators such as transverse
15 electromagnetic (TEM) mode (coaxial) resonators can produce relatively large surface current densities, particularly when used to filter RF signals at powers above hundreds of Watts. Cavity resonator filters are therefore often selected for high-power applications such as filtering RF transmissions at powers on the order of tens to hundreds of kilowatts for reasons of transmitter output spectrum control.

20 **Summary**

It is an object of the invention to provide an improved coupling element with increased coupling strength as compared to conventional systems. A further object of the invention relates to a cavity resonator device for RF signals comprising such coupling element(s).

25

According to the embodiments, this object is achieved by a cavity resonator device comprising at least two adjacent cavity resonators for radio frequency, RF, signals, separated by a common side wall having an opening wherein said cavity resonator device comprises at least one coupling element for coupling two adjacent cavity
30 resonators of said cavity resonator device,

wherein said at least one coupling element comprises a base section and a top section, wherein said top section is displaced vertically from said base section by a first distance along a longitudinal axis of said coupling element, and wherein said coupling element comprises at least a first coupling arm and a second coupling arm, each of
5 said coupling arms connecting said base section with said top section,

wherein said at least one coupling element (100) is arranged rotably around an axis of rotation with respect to said wall in said opening, wherein said axis of rotation is said longitudinal axis of said coupling element or an axis parallel thereto, and wherein said axis of rotation projects through the base section and the top section of the coupling
10 element.

Said coupling element comprises a base section and a top section, wherein said top section is displaced vertically from said base section by a first distance along a longitudinal axis of said coupling element, wherein said coupling element comprises at least a first coupling arm and a second coupling arm, each of said coupling arms
15 connecting said base section with said top section. Particularly, the coupling arms may be distinct from each other, i.e. they do not make electrically conductive contact with each other. Rather, respective end sections of the contact arms make contact with the base section and the top section of the coupling element, respectively.

According to an embodiment, said base section and/or said top section comprises a
20 substantially planar shape. Preferably, said base section and/or said top section substantially comprise a plate shape, i.e. basically a generalized cylindrical shape with a height along a longitudinal axis of the cylindrical shape which is smaller than any dimension of said plate shape in a plane substantially perpendicular to said longitudinal axis.

According to a further embodiment, said first coupling arm comprises a first end section connected to said base section, a second end section connected to said top section, and an intermediate section connecting said first end section with said second end section. Alternatively or in addition thereto, said second coupling arm may comprise a similar or identical shape, i.e., alternatively or in addition to the aforementioned
25 configuration of the first coupling arm, the second coupling arm comprises a first end section connected to said base section, a second end section connected to said top
30 section connected to said base section, a second end section connected to said top

section, and an intermediate section connecting said first end section with said second end section.

According to a further embodiment, at least one of said end sections and/or at least one of said intermediate sections comprises a substantially cylindrical shape. I.e., one or more end section(s) of either the first coupling arm and/or the second coupling arm may comprise a substantially cylindrical shape (wherein "cylindrical" is to be interpreted in the mathematical/geometrical sense of a generalized cylinder, but of course may also comprise e.g. elliptical or circular cylindrical shapes or the like), said substantially cylindrical shape defining a respective longitudinal axis of the respective component.

5

10 Likewise, the intermediate section(s) of either the first coupling arm and/or the second coupling arm may comprise a substantially cylindrical shape (wherein "cylindrical" again is to be interpreted in the mathematical sense of a generalized cylinder, but of course may also comprise e.g. elliptical or circular cylindrical shapes or the like), said substantially cylindrical shape defining a respective longitudinal axis of the respective intermediate section.

15

According to a further embodiment, a longitudinal axis of at least one of said end sections (of either the first or second coupling arm or of both coupling arms) is substantially parallel to said longitudinal axis of said coupling element. In this respect, "substantially parallel" means that an angle between the respective longitudinal axes ranges from about -10 degrees to about +10 degrees.

20

According to a further embodiment, a first angle between said first end section and said intermediate section of said first coupling arm and/or a second angle between said second end section and said intermediate section of said first coupling arm and/or a third angle between said first end section and said intermediate section of said second coupling arm and/or a fourth angle between said second end section and said intermediate section of said second coupling arm ranges between about 50 degrees and about 130 degrees, preferably between about 80 degrees and about 120 degrees, more preferably between about 90 degrees and about 110 degrees. According to this embodiment, two or more of the first to fourth angles may be identical or basically identical (relative difference between the angles smaller than 10 percent) to each other.

25

30

According to further variants of this embodiment, two or more of the first to fourth angles may also comprise different values within the abovementioned ranges each.

According to a further embodiment, at least one of said coupling arms is arranged in a respective virtual plane, wherein an angle between said respective virtual plane and said longitudinal axis of said coupling element ranges between about -20 degrees and about 20 degrees, preferably between about -5 degrees and about 5 degrees. In other words, at least one coupling arm comprises a basically planar configuration along a respective virtual plane. I.e., the end sections and the intermediate section of said at least one coupling arm – or their longitudinal axes, respectively - basically lie within said respective virtual plane.

10 According to a further embodiment, if both coupling arms are basically planar and thus lying in a respective virtual plane, a distance between said virtual planes (or a respective surface of the two coupling arms) may range between about 2 millimeter (mm) and about 100 mm, preferably between about 10 mm and about 50 mm.

15 According to a further embodiment, the first end sections of the first and second coupling arms are arranged in opposing axial end sections of said base section. Alternatively or in addition, the second end sections of the first and second coupling arms are arranged in opposing axial end sections of said top section.

20 According to a further embodiment, a surface of at least one of said coupling arms is curved and comprises a minimum curve radius of about 1 millimeter, preferably of about 5 mm.

25 According to a further embodiment, at least one component of said coupling element is made of electrically conductive material and/or comprises an electrically conductive surface, wherein preferably at least one component is made of metal (e.g., copper) and/or comprises a metallic or metallized surface (e.g., made of copper or silver or the like). The aforementioned variants may also be combined with each other. E.g., according to a further embodiment, the base and top sections may e.g. comprise a basically electrically non-conductive main body, said main bodies being coated with one or more electrically conductive layers, while said coupling arms may comprise electrically conductive material such as copper wire or hollow metallic tubes or the like, said coupling arms being electrically conductively coupled to said base and top sections with their respective end sections.

30

According to a further embodiment, at least one of said coupling arms at least partially comprises an elliptically cylindrical section. Preferably, according to a further embodiment, the coupling arms basically comprise a circular cylindrical shape, either with constant radius of said circular cylindrical shape along a length coordinate of said coupling arm (which length coordinate may also be curved depending on the angular orientation of the end sections with respect to the intermediate section of the coupling arm), or with a radius of said circular cylindrical shape varying along said length coordinate of said coupling arm.

According to a further embodiment, at least one further (i.e., third) coupling arm is provided which connects said base section with said top section in a fashion similar or identical to the first and second coupling arms explained above. Also, according to further embodiments, the third or any further coupling arm may also comprise configurations regarding end sections and/or intermediate sections, angular ranges therebetween and between further coupling arms as explained in detail above for the first and second coupling arms.

The cavity resonator device may e.g. represent or form part of a filter for RF signals.

Advantageous embodiments are the following:

- wall sections adjacent to said opening comprise a slanted front section;
- a tuning mechanism is provided which is coupled with said coupling element for driving movement, preferably rotatable movement, of said coupling element with respect to said wall;
- said coupling element is arranged in said opening such that a first portion of its first coupling arm is positioned within a first one of said adjacent cavity resonators, and that a second portion of its first coupling arm is positioned within a second one of said adjacent cavity resonators, and wherein preferably said coupling element is arranged in said opening such that a first portion of its second coupling arm is positioned within said second one of said adjacent cavity resonators, and that a second portion of its second coupling arm is positioned within said first one of said adjacent cavity resonators.

Further advantageous features of the invention are defined and are described in the following detailed description of the invention.

Brief description of the figures

The embodiments of the invention will become apparent in the following detailed description and will be illustrated by accompanying figures given by way of non-limiting illustrations, wherein:

- Figure 1 schematically depicts a front view of a coupling element according to an embodiment,
- Figure 2 schematically depicts a first coupling arm of the coupling element according to Fig. 1,
- Figure 3 schematically depicts a second coupling arm of the coupling element according to Fig. 1,
- Figure 4 schematically depicts a perspective view of a coupling element according to an embodiment,
- Figure 5 schematically depicts a side view of a coupling element according to an embodiment,
- Figure 6 schematically depicts a front view of a coupling element according to a further embodiment,
- Figure 7 schematically depicts a top view of a coupling element according to a further embodiment,
- Figure 8 schematically depicts a top view of a cavity resonator device according to an embodiment,
- Figure 9 schematically depicts a front view of a cavity resonator device according to an embodiment,
- Figure 10 schematically depicts a top view of a cavity resonator device according to a further embodiment,
- Figure 11 schematically depicts a top view of a cross-section of a filter according to an embodiment, and

Figure 12 schematically depicts an electrical equivalent circuit according to an embodiment.

Description of the embodiments

Figure 1 schematically depicts a front view of a coupling element 100 according to a first embodiment. The coupling element 100 may e.g. be used within a cavity resonator device 1000 for RF signals, cf. the top view of Fig. 8, such as a bandpass filter.

The cavity resonator device 1000 may e.g. comprise at least two adjacent cavity resonators 1010, 1020 separated by a common side wall 1030. The side wall 1030 may have an opening 1032 as depicted by Fig. 8, and in said opening 1032, the coupling element 100 according to the embodiments may be arranged to enable a per se known coupling between the adjacent cavity resonators 1010, 1020.

According to a preferred embodiment, said coupling element 100 is arranged movably with respect to said wall 1030 in said opening 1032, said movement e.g. comprising translation and/or rotation.

According to a particularly preferred embodiment, which is depicted by Fig. 8, said coupling element 100 is arranged rotatably with respect to said wall 1030 in said opening 1032, wherein presently the coupling element 100 is arranged rotatably around its longitudinal axis a_1 that extends basically perpendicular to the drawing plane of Fig. 8. The rotatable movement is also indicated by the double arrows r_1 in Fig. 8 and the dotted rectangular shape indicating the coupling element in a different rotational position. By performing such rotation r_1 within the opening 1032, the coupling element 100 influences the coupling strength between said cavity resonators 1010, 1020 thus enabling to tune a frequency characteristic of the cavity resonator device 1000.

Alternatively to the configuration depicted by Fig. 8, a rotational movement around an axis (not shown) substantially parallel (but not identical to) the longitudinal axis a_1 is also possible according to a further embodiment.

According to a further embodiment, the rotational movement r_1 of the coupling element 100 may either be unlimited or limited to a predetermined range of about e.g. 360 degrees, or 180 degrees or less.

Returning to Fig. 1, the coupling element 100 comprises a base section 110 and a top section 120, wherein said top section 120 is displaced vertically from said base section 110 by a first distance d_1 along said longitudinal axis a_1 of said coupling element 100. The coupling element 100 comprises at least a first coupling arm 130 and a second coupling arm 140, wherein said first coupling arm 130 connects said base section 110 with said top section 120, and wherein said second coupling arm 140 also connects said base section 110 with said top section 120.

According to an embodiment, the coupling arms 130, 140 may be distinct from each other, i.e. they do not make electrically conductive contact with each other. Rather, respective end sections 132, 142, 134, 144 of the contact arms 130, 140 make contact with the base section 110 and the top section 120 of the coupling element 100, respectively.

According to an embodiment, said base section 110 and/or said top section 120 comprises a substantially planar shape. Preferably, said base section 110 and/or said top section 120 substantially comprise a plate shape, i.e. basically a generalized cylindrical shape with a height t_1 along a longitudinal axis a_1 of the cylindrical shape (or along the vertical coordinate y in Fig. 1) which is smaller than any dimension of said plate shape in a plane substantially perpendicular to said longitudinal axis a_1 .

According to a further embodiment, said first coupling arm 130 comprises a first end section 132 connected to said base section 110, a second end section 134 connected to said top section 120, and an intermediate section 136 connecting said first end section 132 with said second end section 134. Alternatively or in addition thereto, said second coupling arm 140 may comprise a similar or identical shape, i.e., alternatively or in addition to the aforementioned configuration of the first coupling arm 130, the second coupling arm 140 comprises a first end section 142 connected to said base section 110, a second end section 144 connected to said top section 120, and an intermediate section 146 connecting said first end section 142 with said second end section 144.

Generally, the expression "connecting" in the context of the aforementioned structure of the coupling arms 130, 140 and their connections to the base and top sections 110, 120 shall denote an electrically conductive (i.e., galvanic) connection of the respective

components with each other, at least as far as a surface of the respective components is concerned (and a penetration depth of electric currents as required by an operational frequency range of the coupling element 100 or the cavity resonator device 1000, e.g. the Skin depth or a multiple thereof). In other words, according to some embodiments, said electrically conductive connection may be established by an electrically conductive coating of or layer on of the respective components 110, 120, 130, 140 which comprises a thickness of about a Skin depth or a multiple thereof, e.g. about 3 micrometers (μm) or more for signals frequencies of about 500 MHz (Megahertz). Of course, alternatively or in addition, some or all components 110, 120, 130, 140 may also comprise solid metallic bodies or hollow metallic bodies (with corresponding wall thickness, cf. the observations with respect to the Skin depth above).

According to a further embodiment, at least one of said end sections 132, 142, 134, 144 and/or at least one of said intermediate sections 136, 146 comprises a substantially cylindrical shape. I.e., one or more end section(s) of either the first coupling arm 130 and/or the second coupling arm 140 may comprise a substantially cylindrical shape (wherein "cylindrical" is to be interpreted in the mathematical sense of a generalized cylinder, but of course may also comprise e.g. elliptical or circular cylindrical shapes or the like), said substantially cylindrical shape defining a respective longitudinal axis of the respective component. Likewise, the intermediate section(s) 136, 146 of either the first coupling arm 130 and/or the second coupling arm 140 may comprise a substantially cylindrical shape (wherein "cylindrical" again is to be interpreted in the mathematical sense of a generalized cylinder, but of course may also comprise e.g. elliptical or circular cylindrical shapes or the like), said substantially cylindrical shape defining a respective longitudinal axis of the respective intermediate section 136.

Figure 2 schematically depicts the first coupling arm 130 of the coupling element 100 according to Fig. 1 in a front view comparable to that of Fig. 1. The base and top sections 110, 120 are illustrated by dotted lines only for the sake of clarity. The first end section 132 of the first coupling arm 130 comprises a longitudinal axis a_2 , which is presently arranged substantially parallel to the longitudinal axis a_1 of the coupling element 100 (Fig. 1). The second end section 134 of the first coupling arm 130 comprises a longitudinal axis a_3 , which is presently also arranged substantially parallel

to the longitudinal axis a1 of the coupling element 100 (Fig. 1). The intermediate section 136 connecting said end sections 132, 134 with each other comprises a longitudinal axis a4.

5 According to a further embodiment, the longitudinal axis a2, a3 of at least one of said end sections 132, 134 is substantially parallel to said longitudinal axis a1 of said coupling element 100. In this respect, "substantially parallel" means that an angle between the respective longitudinal axes a2, a3 and a1 ranges from about -10 degrees to about +10 degrees.

10 According to a further embodiment, a first angle α_1 between said first end section 132 and said intermediate section 136 of said first coupling arm 130 and/or a second angle α_2 between said second end section 134 and said intermediate section 136 of said first coupling arm 130 ranges between about 50 degrees and about 130 degrees, preferably between about 80 degrees and about 120 degrees, more preferably between about 90 degrees and about 110 degrees. Presently, as depicted in Fig. 2, the
15 first and second angles α_1 , α_2 are chosen to be about 120 degrees. However, according to further embodiments, the first and second angles α_1 , α_2 may also be different from each other.

Figure 3 schematically depicts the second coupling arm 140 of the coupling element 100 according to Fig. 1 in a front view comparable to that of Fig. 1. Presently, the
20 second coupling arm 140 comprises a geometry basically similar or identical to the one of the first coupling arm 130 as depicted by Fig. 2. The base and top sections 110, 120 are illustrated in Fig. 3 by dotted lines only, and the first coupling arm 130 is omitted in Fig. 3, for the sake of clarity. The first end section 142 of the second coupling arm 140 comprises a longitudinal axis a5, which is presently arranged substantially parallel to
25 the longitudinal axis a1 of the coupling element 100 (Fig. 1). The second end section 144 of the second coupling arm 140 comprises a longitudinal axis a6, which is presently also arranged substantially parallel to the longitudinal axis a1 of the coupling element 100 (Fig. 1). The intermediate section 146 connecting said end sections 142, 144 with each other comprises a longitudinal axis a7.

30 According to an embodiment, the intermediate sections 136, 146 (Fig. 1) of the two coupling arms 130, 140 are not parallel to each other, but rather include an angle (not

shown) of about 10 degrees or more, preferably about 20 degrees or more, which reduces an undesired magnetic coupling between said intermediate sections 136, 146.

According to a further embodiment, the longitudinal axis a5, a6 of at least one of said end sections 142, 144 is substantially parallel to said longitudinal axis a1 of said coupling element 100. In this respect, "substantially parallel" means that an angle between the respective longitudinal axes a5, a6 and a1 ranges from about -10 degrees to about +10 degrees.

According to a further embodiment, a third angle α_3 between said first end section 142 and said intermediate section 146 of said second coupling arm 140 and/or a fourth angle α_4 between said second end section 144 and said intermediate section 146 of said second coupling arm 140 ranges between about 50 degrees and about 130 degrees, preferably between about 80 degrees and about 120 degrees, more preferably between about 90 degrees and about 110 degrees. Presently, as depicted in Fig. 3, the third and fourth angles α_3 , α_4 are chosen to be about 120 degrees. However, according to further embodiments, the third and fourth angles α_3 , α_4 may also be different from each other (and also similar to or different from the first and second angles α_1 , α_2 of the first coupling arm 130, cf. Fig. 2).

Figure 4 schematically depicts a perspective view of a coupling element 100 according to an embodiment. It can be seen that presently the base and top sections 110, 120 comprise basically rectangular cylindrical shape with a width w1 and a length l1. Presently, the height t1 (cf. Fig. 1) is smaller than said width w1 and said length l1, whereby a "plate shape" is attained for the base and top sections 110, 120. However, according to other embodiments, different shapes are possible for said base and top sections 110, 120, wherein said base section 110 may also comprise a different shape than said top section 120.

According to a further embodiment, one or more of said components 110, 120, 130, 140 of the coupling element 100 – or a respective surface thereof (also cf. the surface 130a of the first coupling arm 130 of Fig. 2) – may be curved and may comprise a minimum curve radius of about 1 millimetres, preferably of about 5 mm. Curved edges of e.g. the base and/or top section(s) 110, 120 are also possible, cf. reference sign 112.

According to a further embodiment, at least one of said coupling arms 130, 140 (Fig. 4) at least partially comprises an elliptically cylindrical section. Preferably, according to a further embodiment, the coupling arms basically comprise a circular cylindrical shape, as schematically depicted by Fig. 4. Presently said circular cylindrical shape comprises a substantially constant radius along a length coordinate of said coupling arm (which length coordinate may also be curved depending on the angular orientation of the end sections with respect to the intermediate section of the coupling arm). Alternatively or in addition, a radius of said circular cylindrical shape may also vary (not shown) along said length coordinate of said coupling arm, at least for one or more sections 132, 134, 136, 142, 144, 146 thereof.

According to a further embodiment, at least one component 110, 120, 130, 140 of said coupling element 100 is made of electrically conductive material and/or comprises an electrically conductive surface, wherein preferably at least one component is made of metal (e.g., copper) and/or comprises a metallic or metallized surface 124, 114, cf. Fig. 1, (e.g., made of copper or silver or the like). The aforementioned variants may also be combined with each other. E.g., according to a further embodiment, the base and top sections may e.g. comprise a basically electrically non-conductive main body, said main bodies being coated with one or more electrically conductive layers, while said coupling arms may comprise electrically conductive material such as copper wire or hollow metallic tubes or the like, said coupling arms being electrically conductively coupled to said base and top sections with their respective end sections.

According to a further embodiment, at least one further (i.e., third) coupling arm (not shown) is provided which connects said base section 110 with said top section 120 in a fashion similar or identical to the first and second coupling arms 130, 140 explained above. Also, according to further embodiments, the third or any further coupling arm may also comprise configurations regarding end sections 132, 134 and/or intermediate sections 136, angular ranges therebetween and between further coupling arms as explained in detail above for the first and second coupling arms 130, 140.

Figure 5 schematically depicts a side view of a coupling element 100 according to an embodiment. As can be seen from Fig. 5, both coupling arms 130, 140 comprise a basically planar configuration in that the first and second end sections 132, 134 and the intermediate section 136 of the first coupling arm 130 lies in a virtual plane p1, which is

presently substantially parallel to the longitudinal axis a1. Also, the first and second end sections 142, 144 and the intermediate section 146 of the second coupling arm 140 lies in a virtual plane p2, which is presently substantially parallel to the longitudinal axis a1. In other words, the virtual planes p1, p2 each comprising one coupling arm 130, 140 are substantially parallel to each other. Preferably, according to a further embodiment, the virtual planes p1, p2 are each arranged with a non-vanishing distance to said longitudinal axis a1 (i.e., the plane(s) p1, p2 not comprising said longitudinal axis a1), said longitudinal axis a1 preferably being arranged between said virtual planes p1, p2.

10 According to a further embodiment, at least one of said coupling arms 130, 140 is arranged in a respective virtual plane p1, p2, wherein an angle between said respective virtual plane p1, p2 and said longitudinal axis a1 of said coupling element 100 ranges between about -20 degrees and about 20 degrees, preferably between about -5 degrees and about 5 degrees. In other words, at least one coupling arm 130, 140
15 comprises a basically planar configuration along a respective virtual plane p1, p2, as stated above. I.e., the end sections and the intermediate section of said at least one coupling arm – or their longitudinal axes, respectively - basically lie within said respective virtual plane.

According to a further embodiment, if both coupling arms are basically planar and thus
20 lying in a respective virtual plane, a distance between said virtual planes (or a respective surface of the two coupling arms) may range between about 2 millimetres (mm) and about 100 mm, preferably between about 10 mm and about 50 mm.

However, according to further embodiments, at least one coupling arm 130, 140, .. may
25 comprise a non-planar configuration (not shown), i.e. at least one section 132, 134, 136 of a specific coupling arm 130 lies outside a first virtual plane p1 comprising one or more other sections of said specific coupling arm 130.

Figure 6 schematically depicts a front view of a coupling element 100 according to a
further embodiment, wherein the first end sections 132, 142 of the first and second
coupling arms 130, 140 are arranged in opposing axial end sections of said base
30 section 110. An longitudinal axis of said base section 110 is parallel to the depicted coordinate axis x, wherein the first end section 142 of the second coupling arm 140 is

arranged within an interval (x_0, x_1) , wherein $x_1 > x_0$, and wherein x_0, x_1 denote coordinates along said coordinate axis x , said interval (x_0, x_1) representing a first axial end section 116a of the base section 110. The first end section 132 of the first coupling arm 130 is arranged within an interval (x_2, x_3) , wherein $x_3 > x_2 > x_1$, and wherein x_3, x_2 denote further coordinates along said coordinate axis x , said interval (x_2, x_3) representing a second axial end section 116b of the base section 110, which is arranged opposite to said first axial end section 116a of the base section 110 along the axis x . Alternatively or in addition, the second end sections 134, 144 of the first and second coupling arms 130, 140 may be arranged in opposing axial end sections 126a, 126b of said top section.

Figure 7 schematically depicts a top view of a coupling element 100 according to a further embodiment. A top surface 122 of the top section 120 may have one or more rounded or curved edges 122. According to a particularly preferred embodiment, said coupling element 100 is arranged rotatably in a target system, such as the cavity resonator device 1000 already explained above with reference to Fig. 8, with respect to a component of said target system. E.g., the coupling element 100 may be arranged rotatably around its longitudinal axis a_1 , cf. Fig. 7, that extends basically perpendicular to the drawing plane of Fig. 7, whereby the rotational degree of freedom is indicated in Fig. 7 by means of the double arrows r_1 .

As explained above, Figure 8 schematically depicts a top view of the cavity resonator device 1000 with the coupling element 100 arranged rotatably around its longitudinal axis a_1 in an opening 1032 of a side wall 1030 of said cavity resonator device 1000. According to an embodiment, the opening can be partial, meaning that the depth or length of the opening is not necessarily equal to the cavity height.

Figure 9 schematically depicts a front view of the cavity resonator device 1000 of Fig. 8, and it can be seen that the coupling element 100 extends partially into both adjacent cavity resonators 1010, 1020 of the cavity resonator device 1000.

More specifically, according to an embodiment, said coupling element 100 is arranged in said opening 1032 (Fig. 8) such that a first portion of its first coupling arm 130 (Fig. 9) is positioned within a first one of said adjacent cavity resonators and that a second

portion of its first coupling arm is positioned within a second one of said adjacent cavity resonators, wherein preferably said coupling element 100 is further arranged in said opening such that a first portion of its second coupling arm 140 is positioned within a said second one of said adjacent cavity resonators and that a second portion of its
5 second coupling arm 140 is positioned within said first one 1010 of said adjacent cavity resonators. Presently, as depicted by Fig. 9, the first end section 132 of the first coupling arm 130 is positioned within the cavity resonator 1020 and the second end section 134 of the first coupling arm 130 is positioned within the adjacent cavity resonator 1010, and the first end section 142 of the second coupling arm 140 is
10 positioned within said cavity resonator 1010, and the second end section 144 of the second coupling arm 140 is positioned within said cavity resonator 1020.

According to a further embodiment, a tuning mechanism 1040, e.g. comprising a tuning knob, is provided which is coupled with said coupling element 100 for driving movement, preferably rotatable movement, of said coupling element 100 with respect
15 to said wall 1030 (Fig. 8). Thus, the degree of coupling between the cavity resonators 1010, 1020 defined by the coupling element 100 and its rotational position within the opening 1032 in the wall 1030 may be altered by actuating the tuning knob 1040 external to the resonator cavities, which is also possible during operation of said cavity resonator device.

20 According to a further embodiment, per se known loading elements 1010a, 1020a may be provided within said cavity resonators 1010, 1020. The loading elements 1110, 1120 may also be adjustable according to some embodiments.

According to a further embodiment, cf. Fig. 10, wall sections 1030a, 1030b adjacent to said opening 1032 comprise a slanted front section 1030a', 1030b', which enables to
25 extend a rotational movement range of the coupling element 100 within said opening 1032.

Advantageously, the coupling element 100 according to the embodiments enables an adjustable phase-reversing coupling between cavity resonators 1010, 1020 with an increased coupling strength as compared to conventional systems.

Using the coupling element 100 according to the embodiments, cavity resonator devices 1000 such as high-power bandpass filters for RF signals may be provided, which may e.g. operate in frequency ranges of about 50 MHz up to about some GHz and in power ranges of about some Watts (W) up to 100 kW (kilowatt) or even more.

5 Figure 11 is a top view of a cross-section of a cavity resonator device 1000a configured as a filter for RF signals according to some embodiments. The cross-sectional view is perpendicular to a base plate (not shown in Fig. 11) of the filter 1000a and a cover plate (not shown in Fig. 11) of the filter 1000a and the cross-section is located within the filter 1000a between the base plate and the cover plate. Some embodiments of the
10 filter 1000a may be a bandpass filter that is deployed in the receive path or transmit path of a radio frequency communication system. The radio frequency communication system may include base stations or access points that transmit, receive, or broadcast RF signals to user equipment within a wireless communication system. For example, the filter 1000a may be used to filter signals that are broadcast by a broadcast station
15 at relatively high power, e.g., at powers near or above 10 kW. Some embodiments of the filter 1000a may be tunable or adjustable to selectively filter signals in a frequency range between 400 MHz and 900 MHz or other frequency ranges. According to some embodiments, adjustability is required for two reasons: 1. to track a filter's bandwidth over a tuning range, 2. To suit a variety of different selectivity masks for different global
20 transmission modes, like DVB-T, ISDB-T, ATSC, etc. In other applications different modes may require different bandwidths. Adjusting the bandwidth of the filter 1000a may include changing the center frequency or the filter bandwidth or a selectivity mask. According to some embodiments, filter center frequency tuning and filter bandwidth tuning are two separate things. A national transmission frequency range may be
25 470MHz to 700MHz and the filter bandwidth may be 6,7 or 8MHz for example and the filter passband width needs to be constant over the filter tuning range.

The filter 1000a is formed of six cavity resonators 1101, 1102, 1103, 1104, 1105, 1106 (collectively referred to as "the cavity resonators 1101-1106"). However, some embodiments of the filter 1000a may include more or fewer cavity resonators. Some
30 embodiments of the cavity resonators 1101-1106 may be implemented as TE-101 mode resonators or transverse electromagnetic wave mode (TEM) resonators. One or more of the cavity resonators 1101-1106, presently all cavity resonators 1101-1106,

may include a corresponding inner conductor or loading element 1111, 1112, 1113, 1114, 1115, 1116 (collectively referred to as “the loading elements 1111-1116”) that can be adjusted to change the loading, which may be a capacitive loading, in the cavity resonators 1101-1106, thereby changing the frequency response or transfer function of the cavity resonators 1101-1106. For example, loading elements 1111-1116 may be implemented using resonator rods and the depth of the resonator rod into the corresponding cavity resonator 1101-1106 may determine the capacitive loading. However, other types of loading elements 1111-1116 may be implemented in the cavity resonators 1101-1106.

Radio frequency signals may be introduced into the filter 1000a through an input port coupling 1200 in the cavity resonator 1101. The RF signals in the cavity resonator 1101 may then be transferred into the cavity resonator 1102 via a coupling structure 100a, into the cavity resonator 1103 via a coupling structure 100b, into the cavity resonator 1104 via a coupling structure 100c, into the cavity resonator 1105 via a coupling structure 100d, and into the cavity resonator 1106 via a coupling structure 100e. According to an embodiment, the coupling structures 100a to 100e may be referred to as direct coupling structures because they couple electromagnetic waves along a direct path from the input port 1200, through the cavity resonators 1101-1106, and out of an output port 1300. Some embodiments of the coupling structures 100a-100e may be implemented as electrical or capacitive coupling structures in order to suit a chosen coupling scheme for a given filter transfer function response. The filter 1000a may be referred to as a “U-shaped” folded filter because the cavity resonators 1101-1106 are deployed in an arrangement that resembles the letter U. However, some embodiments of the filter 1000a may implement other configurations of the cavity resonators 1101-1106 and more or fewer cavity resonators 1101-1106 may be deployed to form embodiments of the filter 1000a.

Some of the cavity resonators 1101-1106 may be cross-coupled. For example, the cavity resonators 1102, 1105 may be cross-coupled using a quasi-capacitive coupling structure 100f.

According to an embodiment, the quasi-capacitive coupling structure 100f may be configured similar or identical to the coupling element 100 explained above with

reference to Fig. 1 to 10, e.g. may have a same or similar shape and/or same or similar properties.

According to a further embodiment, the quasi-capacitive coupling structure 100f may partially encompass a first area in a plane that is substantially perpendicular to a magnetic field in the cavity resonator 1102 and a second portion that may partially encompasses a second area in a plane that is substantially perpendicular to the magnetic field in the cavity resonator 1105. Inductive currents generated in the first portion (e.g., in a first end section 132 of a first coupling arm 130, also cf. Fig. 1) of the quasi-capacitive coupling structure 100f flow in substantially the same direction as current in the second portion (e.g., in a second end section 134 of the first coupling arm 130, also cf. Fig. 1).

According to an embodiment, the quasi-capacitive coupling structure 100f may invert the phase of RF signals that are conveyed between the cavity resonator 1102 and the cavity resonator 1105 (Fig. 11). Consequently, the quasi-capacitive coupling structure 100f maintains the correct phase relationships between signals in the coupled resonators 1102, 1105 and preserves the overall shape of the transfer function of the filter 1000a. Some embodiments of the quasi-capacitive coupling structure 100f can be rotated to adjust its coupling strength. Adjustments to the coupling constant may e.g. be performed in coordination with adjusting a frequency response of one or more of the cavity resonators 1101-1106 to produce a target transfer function of the filter 1000a.

Generally, more than one coupling element 100, 100f according to the embodiments may be employed in cavity resonator devices 1000, 1000a such as e.g. RF bandpass filters and the like.

Fig. 12 depicts an effective electrical equivalent circuit 205 of the coupling element 100 together with two associated cavity resonators 1010, 1020, as e.g. depicted by Fig. 9, according to some embodiments. A coupled cavity resonator pair may e.g. include a first cavity resonator 1010 (Fig. 9) and a second cavity resonator 1020, wherein the cavities are formed of a respective cover plate 1010b, 1020b, a respective base plate 1010c, 1020c, and a common side wall 1030. Each of the cavity resonators 1010, 1020 may include a corresponding loading element 1010a, 1020a, as already mentioned above, that can be adjusted to change the capacitive loading in the cavity resonators

1010, 1020, thereby changing the resonator frequency of the cavity resonators 1010, 1020 and the coupled cavity resonator pair. Some embodiments of the coupled cavity resonator pair may be implemented as the cross-coupled cavity resonators 1102, 1105 in the filter 1000a shown in Fig. 11.

5 Returning to Fig. 9, the cavity resonators 1010, 1020 are coupled by the coupling element 100, acting e.g. as a quasi-capacitive coupling loop. Portions of the coupling element 100 define areas in the cavity resonators 1010, 1020. For example, section 134 of the first coupling arm 130 partially encompasses a first area A1 (also cf. Fig. 1) in the cavity resonator 1010 that is also bounded by the longitudinal axis a1 (as well as
10 by portions of the top section 120 and the intermediate section 136), and section 132 of the first coupling arm 130 partially encompasses a second area A2 (also cf. Fig. 1) in the cavity resonator 1020 (Fig. 9) that is also bounded by the longitudinal axis a1. The second coupling arm 140 defines similar coupling areas A3, A4 (Fig. 1). Magnetic fields near the common wall 1030 (Fig. 9) of the cavity resonators 1010, 1020 may pass
15 through or „penetrate“ into the projected loop areas and thereby induce a coupling current in the loops, and the areas A1, A2, A3, A4 (cf. Fig. 1) bounded by the coupling arms 130, 140 of the coupling element 100 are in the plane of Fig. 9. Thus, the areas A1, A2, A3, A4 bounded by the coupling element 100 may lie in a plane that is substantially perpendicular to magnetic fields in the cavity resonators 1010, 1020.
20 However, the magnetic field may not be perfectly perpendicular to the plane of Fig. 9 and may include components that are in the plane of Fig. 9. The term “substantially perpendicular” is intended to encompass these variations in the direction of the magnetic field near the common wall 1030 of the cavity resonators 1010, 1020.

Magnetic fields produced by electromagnetic waves in the cavity resonators 1010,
25 1020 may produce an inductive current in the coupling arms 130, 140 of the coupling element 100. For example, introducing RF signals into the cavity resonator 1010 produces time varying magnetic fields in the sections 134, 142 of the coupling element 100 that lie within the cavity resonator 1010. The inductive current may flow through the sections 134, 142 of the coupling element 100 in a substantially same direction,
30 which causes corresponding currents in the further sections 132, 144 of the coupling element 100 thus effecting a magnetic coupling from the first cavity resonator 1010 via said coupling element 100 to said second cavity resonator 1020.

According to an embodiment, a current direction through the coupling arms 130, 140 determines a phase angle of the coupling between electromagnetic waves in the cavity resonators 1010, 1020. Since the direction of the current in the sections 134, 132 and 144, 142 is substantially the same, the phase of electromagnetic waves is inverted by traversing the coupling element's arms 130, 140 between the cavity resonators 1010, 1020 relative to the phase produced by traditional U-shaped coupling loops. According to an embodiment, coupling may exist only between vertical sections 132, 134, 142, 144 of the coupling element 100 and the adjacent cavity resonators 1010, 1020 because of an axisymmetric magnetic field direction about the loading elements 1010a, 1020a within the cavity resonators 1010, 1020. Consequently, advantageously a quasi-capacitive coupling is achieved at a location where conventionally only inductive coupling is possible.

The coupled cavity resonator pair 1010, 1020 of Fig. 9 may be represented by the effective electrical equivalent circuit 205 depicted by Fig. 12. For example, the cavity resonator 1010 may be represented by inductances 251, 252 and capacitor 253. The cavity resonator 1020 may be represented by inductances 255, 256 and capacitor 257. The quasi-capacitive coupling between the cavity resonators 1010, 1020 formed by the coupling element 100 may then be represented by the capacitor 260. The strength of the quasi-capacitive coupling may inter alia be determined by the areas A1, A2, A3, A4 bounded by the coupling arms 130, 140 in the cavity resonators 1010, 1020 and hence e.g. be influenced by rotating said coupling element 100 around its longitudinal axis a1 (Fig. 9), whereby the effective coupling areas are altered. Also, due to the presence of at least two coupling arms 130, 140, the coupling element 100 according to the embodiments offers a particularly strong coupling as compared to conventional systems. According to some embodiments, the coupling may further be enhanced by adding a third or even further coupling arms.

The coupling element and the cavity resonator device according to the embodiments advantageously enable to provide high-performance high-power RF filters 1000a with optimized peak-power and average-power handling, as well as external adjustability and moderate costs as compared with conventional systems. Also, undesired self-resonances inside an operational filter tuning range may be avoided when employing the inventive approach.

The description and drawings merely illustrate the principles of the invention. It will thus be appreciated that those skilled in the art will be able to devise various arrangements that, although not explicitly described or shown herein, embody the principles of the invention and are included within its spirit and scope. Furthermore, all examples recited
5 herein are principally intended expressly to be only for pedagogical purposes to aid the reader in understanding the principles of the invention and the concepts contributed by the inventor(s) to furthering the art, and are to be construed as being without limitation to such specifically recited examples and conditions. Moreover, all statements herein reciting principles, aspects, and embodiments of the invention, as well as specific
10 examples thereof, are intended to encompass equivalents thereof.

It should be appreciated by those skilled in the art that any block diagrams herein represent conceptual views of illustrative circuitry embodying the principles of the invention. Similarly, it will be appreciated that any flow charts, flow diagrams, state transition diagrams, pseudo code, and the like represent various processes which may
15 be substantially represented in computer readable medium and so executed by a computer or processor, whether or not such computer or processor is explicitly shown.

Claims

- 5 1. Cavity resonator device (1000) comprising at least two adjacent cavity resonators (1010, 1020) for radio frequency, RF, signals, separated by a common side wall (1030) having an opening (1032) wherein said cavity resonator device (1000) comprises at least one coupling element (100) for coupling two adjacent cavity resonators (1010, 1020) of said cavity resonator device (1000), wherein said at least one coupling element (100) comprises a base section (110) and a top section (120), wherein said top section (120) is displaced vertically from said base section (110) by a first distance (d1) along a longitudinal axis (a1) of said coupling element (100), and wherein said coupling element (100) comprises at least a first coupling arm (130) and a second coupling arm (140), each of said coupling arms (130, 140) connecting said base section (110) with said top section (120), wherein said at least one coupling element (100) is arranged rotably around an axis of rotation with respect to said wall (1030) in said opening (1032), wherein said axis of rotation is said longitudinal axis (a1) of said coupling element (100) or an axis parallel thereto, and wherein said axis of rotation projects through the base section (110) and the top section (120) of the coupling element (100).
- 10
- 15
- 20
- 25 2. Cavity resonator device (1000) according to claim 1, wherein said base section (110) and/or said top section (120) comprises a substantially planar shape, and wherein preferably said base section (110) and/or said top section (120) substantially comprise plate shape.
- 30 3. Cavity resonator device (1000) according to one of claims 1 and 2, wherein said first coupling arm (130) comprises a first end section (132) connected to said base section (110), a second end section (134) connected to said top section (120), and an intermediate section (136) connecting said first end section (132) with said second end section (134), and/or wherein said second coupling arm (140) comprises a first end section (142) connected to said base section (110),

a second end section (144) connected to said top section (120), and an intermediate section (146) connecting said first end section (142) with said second end section (144).

- 5 4. Cavity resonator device (1000) according to claim 3, wherein at least one of said end sections (132, 134, 142, 144) and/or at least one of said intermediate sections (136, 146) comprises a substantially cylindrical shape.
- 10 5. Cavity resonator device (1000) according to one of the claims 3 to 4, wherein a longitudinal axis (a2, a3, a5, a6) of at least one of said end sections (132, 134, 142, 144) is substantially parallel to said longitudinal axis (a1) of said coupling element (100).
- 15 6. Cavity resonator device (1000) according to one of the claims 3 to 5, wherein
- a first angle (α_1) between said first end section (132) and said intermediate section (136) of said first coupling arm (130) and/or
 - a second angle (α_2) between said second end section (134) and said intermediate section (136) of said first coupling arm (130) and/or
 - a third angle (α_3) between said first end section (142) and said intermediate section (146) of said second coupling arm (140) and/or
 - a fourth angle (α_4) between said second end section (144) and said intermediate section (146) of said second coupling arm (140)
- 20 ranges between about 50 degrees and about 130 degrees, preferably between about 80 degrees and about 120 degrees, more preferably between about 90 degrees and about 110 degrees.
- 25 7. Cavity resonator device (1000) according to one of the claims 3 to 6, wherein at least one of said coupling arms (130, 140) is arranged in a respective virtual plane (p1, p2), wherein an angle between said respective virtual plane (p1, p2) and said longitudinal axis (a1) of said coupling element (100) ranges between

about -20 degrees and about 20 degrees, preferably between about -5 degrees and about 5 degrees.

- 5 8. Cavity resonator device (1000) according to one of the claims 3 to 7, wherein the first end sections (132, 142) of the first and second coupling arms (130, 140) are arranged in opposing axial end sections (116a, 116b) of said base section (110), and/or wherein the second end sections (134, 144) of the first and second coupling arms (130, 140) are arranged in opposing axial end sections (126a, 126b) of said top section (120).
- 10 9. Cavity resonator device (1000) according to one of the preceding claims, wherein a surface (130a, 140a) of at least one of said coupling arms (130, 140) is curved and comprises a minimum curve radius of about 1 millimetre, preferably of about 5 millimetre.
- 15 10. Cavity resonator device (1000) according to one of the preceding claims, wherein at least one component (110, 120, 130, 140) is made of electrically conductive material and/or comprises an electrically conductive surface, wherein preferably at least one component (110, 120, 130, 140) is made of metal and/or comprises a metallic or metallized surface.
- 20 11. Cavity resonator device (1000) according to one of the preceding claims, wherein at least one of said coupling arms (130, 140) at least partially comprises an elliptically cylindrical section.
- 25 12. Cavity resonator device (1000) according to one of the preceding claims, wherein at least one further coupling arm is provided which connects said base section (110) with said top section (120).
13. Cavity resonator device (1000) according to one of the preceding claims, wherein wall sections (1030a, 1030b) adjacent to said opening (1032) comprise a slanted front section (1030a', 1030b').
14. Cavity resonator device (1000) according to one of the preceding claims, wherein a tuning mechanism (1040) is provided which is coupled with said

coupling element (100) for driving movement, preferably rotatable movement, of said coupling element (100) with respect to said wall (1030).

- 5 15. Cavity resonator device (1000) according to one of the preceding claims, wherein said coupling element (100) is arranged in said opening (1032) such that a first portion of its first coupling arm (130) is positioned within a first one (1010) of said adjacent cavity resonators, and that a second portion of its first coupling arm (130) is positioned within a second one (1020) of said adjacent cavity resonators, and wherein preferably said coupling element (100) is arranged in said opening (1032) such that a first portion of its second coupling arm (140) is positioned within said second one (1020) of said adjacent cavity resonators, and that a second portion of its second coupling arm (140) is positioned within said first one (1010) of said adjacent cavity resonators.
- 10

Fig. 1

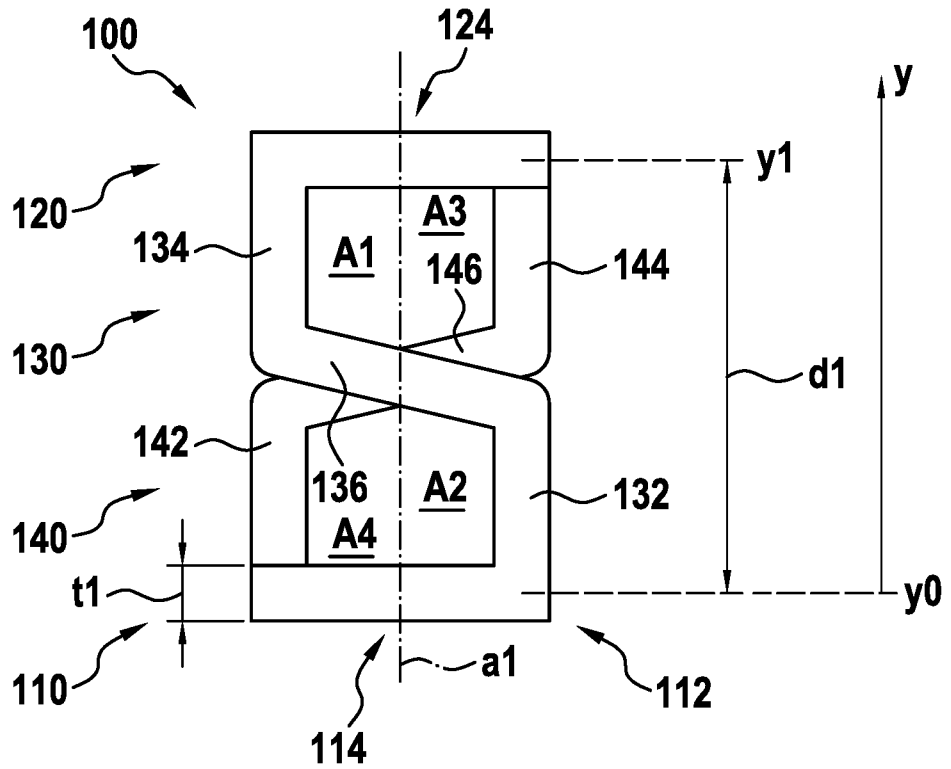

Fig. 2

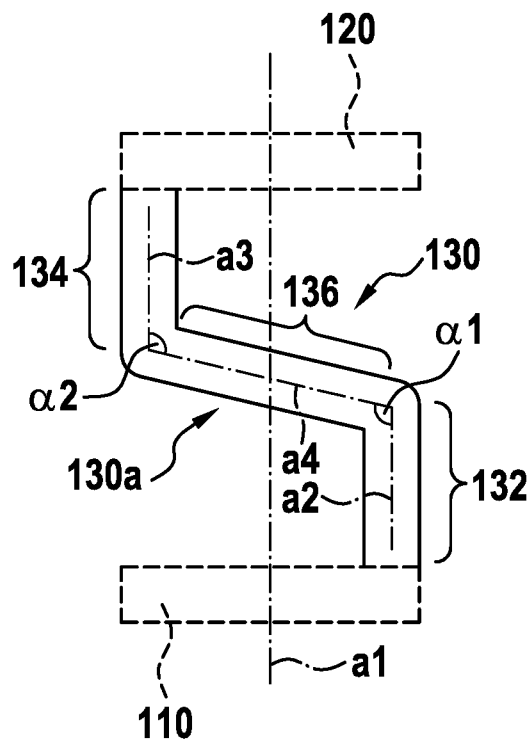

Fig. 3

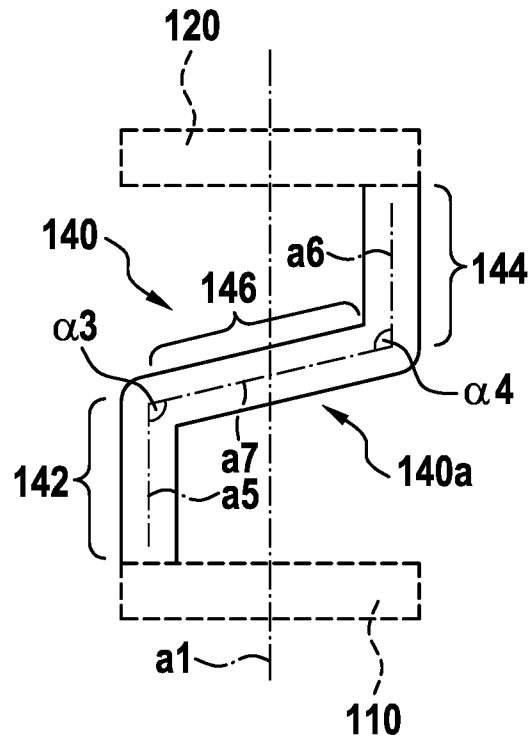

Fig. 4

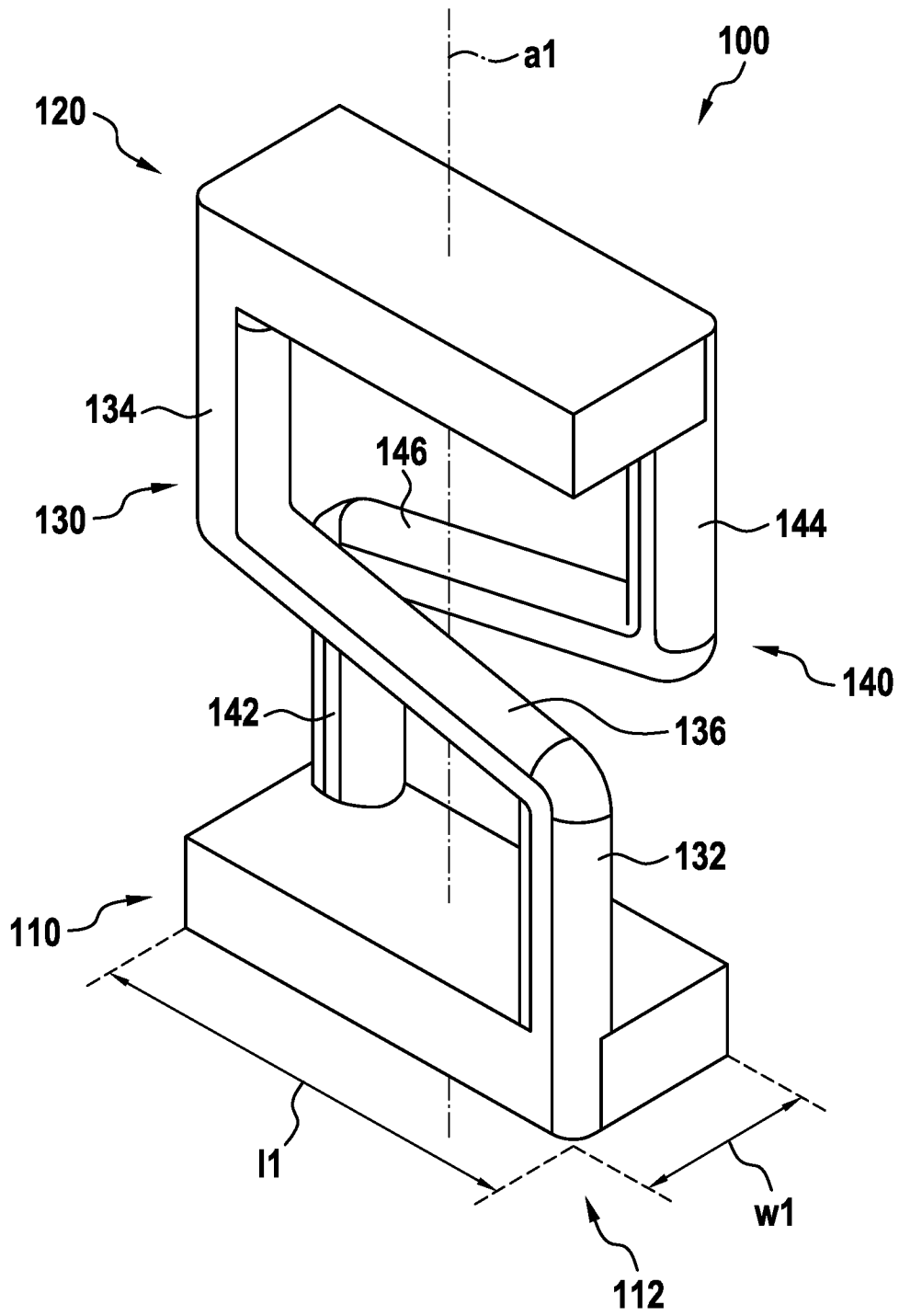

Fig. 7

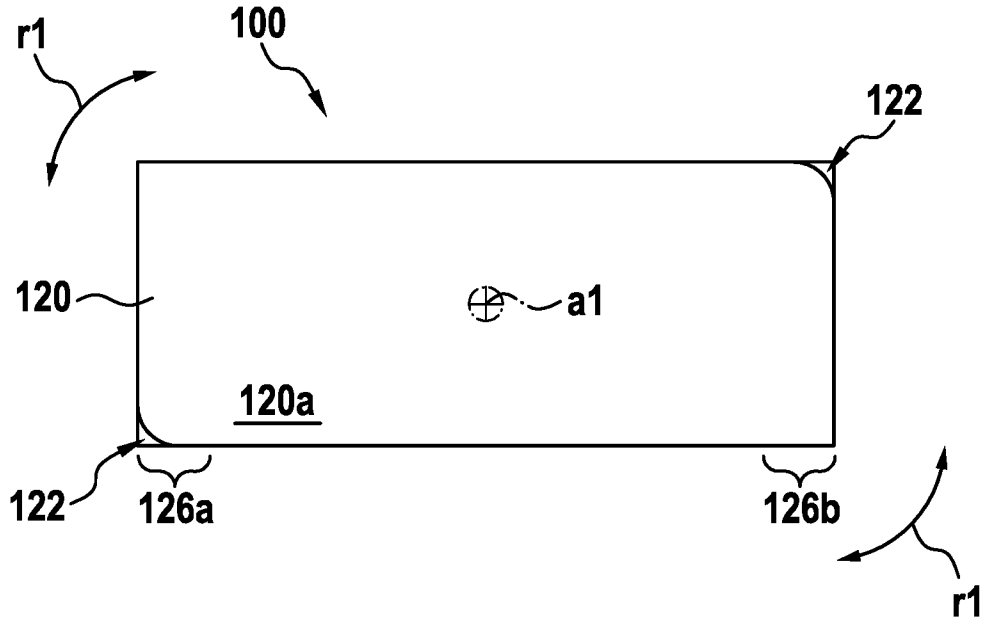

Fig. 8

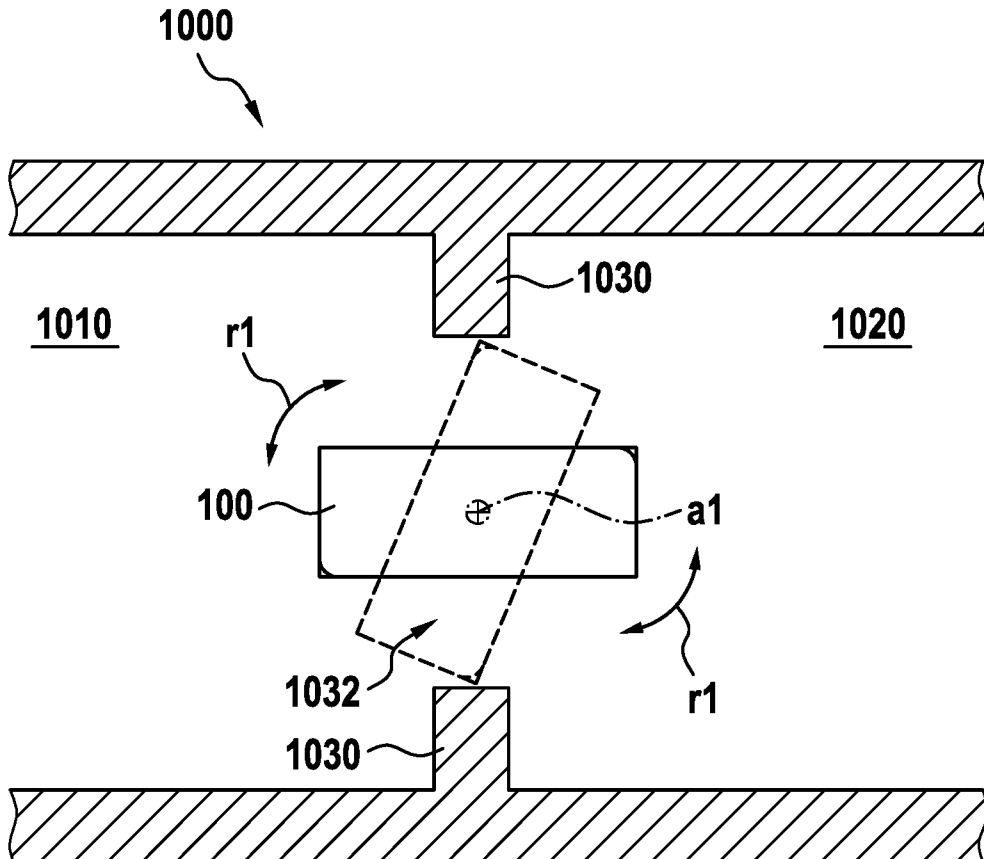

Fig. 9

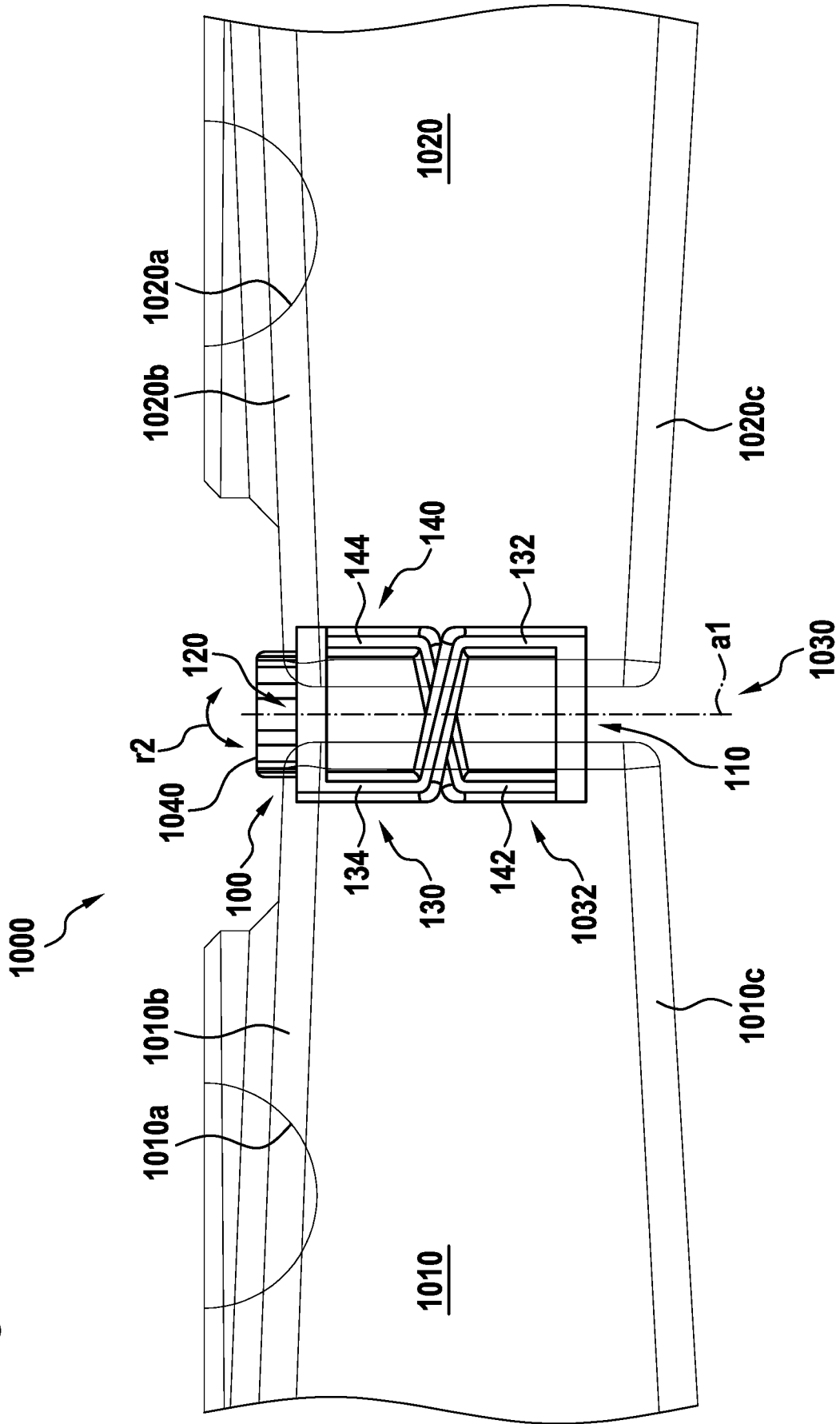

Fig. 10

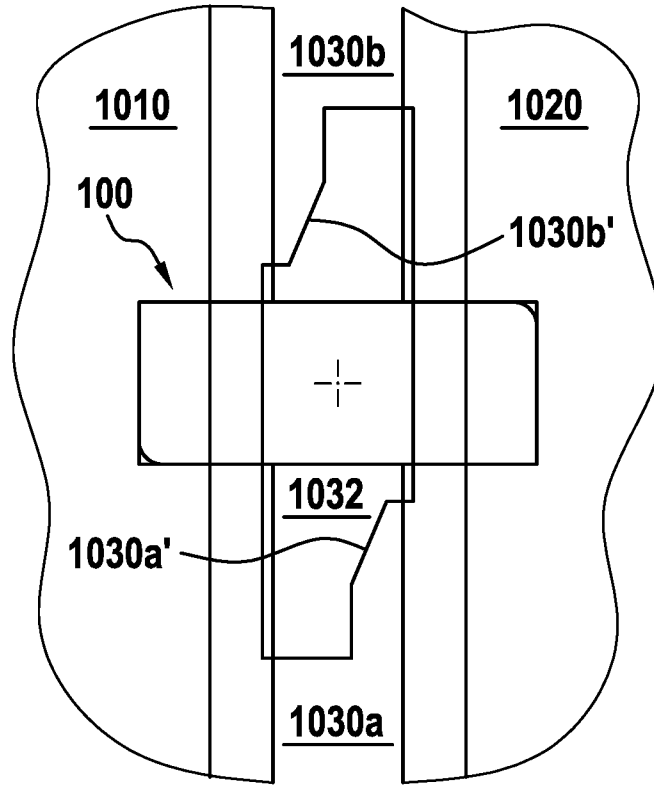

Fig. 11

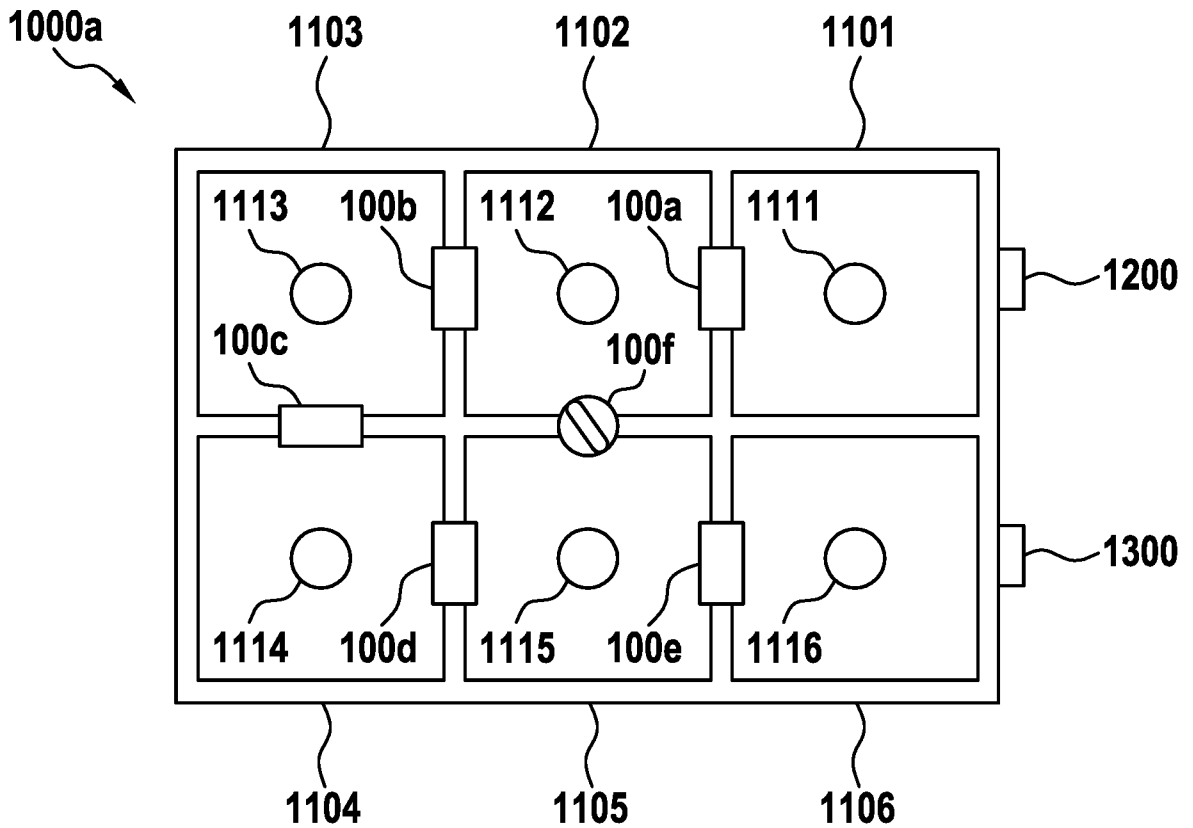
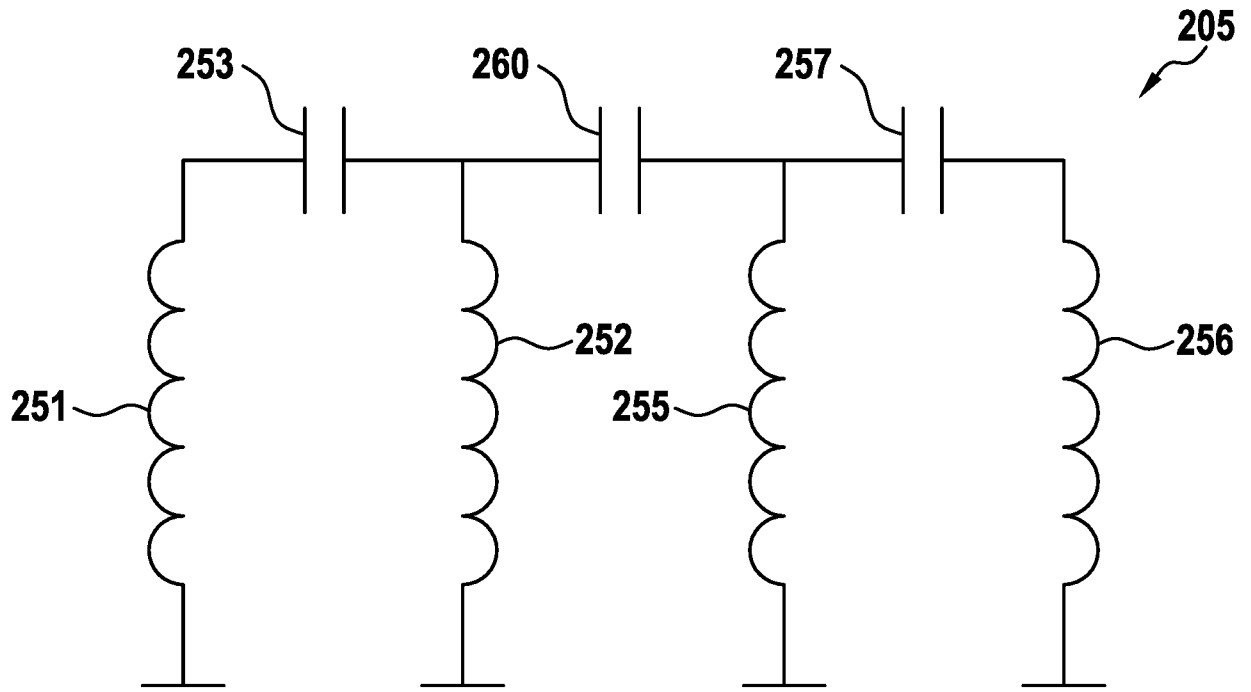

Fig. 12



INTERNATIONAL SEARCH REPORT

International application No.

PCT/IB2016/053882

A. CLASSIFICATION OF SUBJECT MATTER		
H01P 1/20(2006.01)i		
According to International Patent Classification (IPC) or to both national classification and IPC		
B. FIELDS SEARCHED		
Minimum documentation searched (classification system followed by classification symbols)		
H01P		
Documentation searched other than minimum documentation to the extent that such documents are included in the fields searched		
Electronic data base consulted during the international search (name of data base and, where practicable, search terms used)		
WPI, EPODOC, CNPAT, CNKI: cavity, resonator, coupl+, axis, longitud+, adjacent, rotably, rotat+, RF, wall, opening, base, top, arm.		
C. DOCUMENTS CONSIDERED TO BE RELEVANT		
Category*	Citation of document, with indication, where appropriate, of the relevant passages	Relevant to claim No.
X	CN 102738542 A (SPINNER GMBH) 17 October 2012 (2012-10-17) paragraphs 10-22 of the description, figures 1, 2a-2c, claims 1-9, 12-13	1-5, 7, 10-12, 14
A	CN 103518287 A (HUAWEI TECHNOLOGIES CO., LTD.) 15 January 2014 (2014-01-15) the whole document	1-15
A	CN 101517823 A (LUCENT TECHNOLOGIES INC.) 26 August 2009 (2009-08-26) the whole document	1-15
A	US 5805033 A (ALLEN TELECOM INC.) 08 September 1998 (1998-09-08) the whole document	1-15
<input type="checkbox"/> Further documents are listed in the continuation of Box C. <input checked="" type="checkbox"/> See patent family annex.		
* Special categories of cited documents: "A" document defining the general state of the art which is not considered to be of particular relevance "E" earlier application or patent but published on or after the international filing date "L" document which may throw doubts on priority claim(s) or which is cited to establish the publication date of another citation or other special reason (as specified) "O" document referring to an oral disclosure, use, exhibition or other means "P" document published prior to the international filing date but later than the priority date claimed "T" later document published after the international filing date or priority date and not in conflict with the application but cited to understand the principle or theory underlying the invention "X" document of particular relevance; the claimed invention cannot be considered novel or cannot be considered to involve an inventive step when the document is taken alone "Y" document of particular relevance; the claimed invention cannot be considered to involve an inventive step when the document is combined with one or more other such documents, such combination being obvious to a person skilled in the art "&" document member of the same patent family		
Date of the actual completion of the international search		Date of mailing of the international search report
16 August 2016		27 September 2016
Name and mailing address of the ISA/CN		Authorized officer
STATE INTELLECTUAL PROPERTY OFFICE OF THE P.R.CHINA 6, Xitucheng Rd., Jimen Bridge, Haidian District, Beijing 100088 China		GU, Yizhen
Facsimile No. (86-10)62019451		Telephone No. (86-10)010-82246963

INTERNATIONAL SEARCH REPORT
Information on patent family members

International application No.

PCT/IB2016/053882

Patent document cited in search report			Publication date (day/month/year)	Patent family member(s)			Publication date (day/month/year)
CN	102738542	A	17 October 2012	DE	102011016487	A1	11 October 2012
				EP	2509152	A2	10 October 2012
CN	103518287	A	15 January 2014	None			
CN	101517823	A	26 August 2009	EP	2070152	A1	17 June 2009
				KR	20090042974	A	04 May 2009
				JP	2010504063	A	04 February 2010
				WO	2008036179	A1	27 March 2008
				US	2008068104	A1	20 March 2008
				INCHENP	200901475	E	21 August 2009
US	5805033	A	08 September 1998	CA	2246720	A1	28 August 1997
				EP	1195840	A2	10 April 2002
				CN	1217090	A	19 May 1999
				EP	0943160	A1	22 September 1999
				WO	9731402	A1	28 August 1997
				KR	19990087231	A	15 December 1999