

Nov. 16, 1971

M. ERNST

3,619,941

COUPLING FOR TOY AND MODEL RAILROADS

Filed July 22, 1969

2 Sheets-Sheet 1

Fig. 1

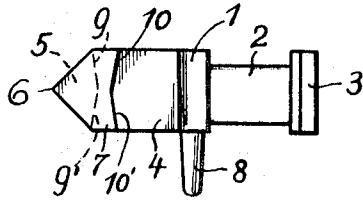

Fig. 2

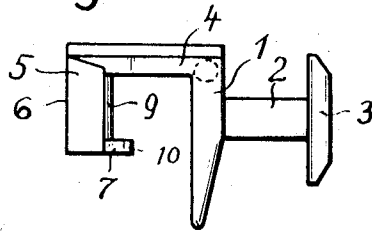
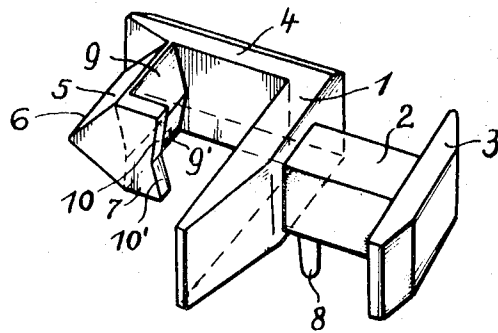

Fig. 3



Nov. 16, 1971

M. ERNST

3,619,941

COUPLING FOR TOY AND MODEL RAILROADS

Filed July 22, 1969

2 Sheets-Sheet 2

Fig. 4

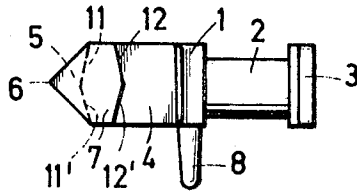

Fig. 5

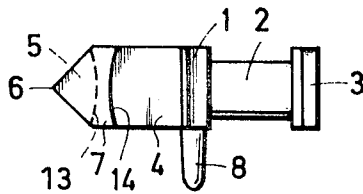
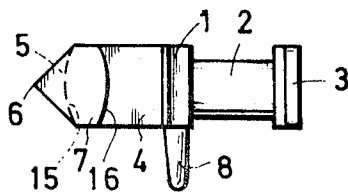

Fig. 6



1

2

3,619,941
COUPLING FOR TOY AND MODEL RAILROADS
Max Ernst, 14 Lohengrinstrasse, 85 Nuremberg, Germany
Filed July 22, 1969, Ser. No. 843,654
Claims priority, application Germany, July 23, 1968,
P 17 03 876.5
Int. Cl. A63h 19/00
U.S. Cl. 46—216 2 Claims

ABSTRACT OF THE DISCLOSURE

A coupling member consisting of a single integral piece with two arms arranged substantially rectangularly with regard to each other, in which one arm has a first member with protruding surface means and has a second member with protruding surface means for nesting in a surface corresponding to said first surface and pertaining to a second coupling member to be coupled to the first mentioned coupling member.

The present invention relates to couplings for vehicles of toy and model railroads. Couplings for vehicles of toy and model railroads are known according to which each coupling section forms a single piece with a coupling hook and a holding portion connected thereto. The coupling hook proper is formed by profiled legs arranged perpendicularly with regard to each other. More specifically, one of the legs forms a relatively wide transverse web while another leg is at a right angle thereto and forms a longitudinal web connected to one end of said transverse web. Connected to the end of the longitudinal web and at a right angle to the longitudinal vehicle axis there is a coupling nose with an outwardly located edge and with a short and narrow confining web connected to the end of the coupling nose and extending at a right angle to the coupling holding means. The coupling hooks are by spring means held with their holding portion in their central position while said coupling hooks when loading said spring are tiltable upwardly as well as to both sides and can also be moved backwardly. When two vehicles equipped with such coupling sections are moved toward each other, the coupling hooks with their edges and adjacent inclined surfaces of their noses engage each other in such a way that the hook with the somewhat higher edge escapes in upward direction and its nose catches behind the nose of the other coupling section.

With the heretofore known coupling, the coupling noses are formed of profiles which have a triangular cross section and which are so oriented that they form the edge by two outer inclined surfaces and on the inner side of the coupling nose are delimited by a vertical plane surface. Similarly, the confining surface directed toward the transverse web and pertaining to the confining web adjacent the coupling nose forms a vertical plane surface.

When the coupling hooks engage each other and when the vehicle exerts a pull, the vertical confining surfaces of the two confining webs engage the vertical confining surfaces on the inside of the coupling noses. During this operation, it happens occasionally, especially when driving over a switch, that the coupling hooks are with regard to each other subjected to vertical forces in view of which, while overcoming the frictional forces between the coupling hooks, they disengage each other with the result that the vehicles are disconnected from each other.

It is, therefore, an object of the present invention to provide a coupling member for toy and model railroads which will overcome the above mentioned drawback.

This object and other objects and advantages of the invention will appear more clearly from the following speci-

fication, in connection with the accompanying drawings, in which:

FIG. 1 is a side view of a coupling member according to the present invention.

FIG. 2 is a top view of the coupling member of FIG. 1.

FIG. 3 shows an isometric view of the coupling member of FIGS. 1 and 2.

FIG. 4 is a side view of a modified coupling member according to the invention.

FIG. 5 is a side view of a further modification of a coupling member according to the invention.

FIG. 6 represents still another modification of the coupling member according to the invention likewise in side view.

The coupling according to the present invention which consists of a single integral piece having a holding portion and a hook portion arranged adjacent said holding portion, and in which said hook portion comprises a relatively wide transverse web and a longitudinal web extending at least approximately at an angle of 90° with regard to said transverse web while a coupling nose member extends transverse to said longitudinal web in spaced relationship to said transverse web and has one side facing said transverse web and has its opposite side provided with tapered surface means, is characterized primarily in that the inner side of the coupling nose is formed by a protruding surface while the surface of a confining web at that end of the coupling nose member which is remote from said longitudinal web is provided with a concave confining surface, or vice versa.

These two surfaces may either be slightly curved or they may form an obtuse angle with each other.

In engaged position and when the two vehicles equipped with the coupling members are being pulled, for instance, the hollow confining surfaces at the end of the confining webs engage the protruding confining surfaces on the inner side of the coupling noses or vice versa. An accidental disengagement by, for instance, vertical forces acting upon the coupling hooks will thus be made considerably more difficult and for all practical purposes will be completely eliminated.

A particularly advantageous embodiment is obtained when the hollow and correspondingly protruding surfaces which engage each other are formed by two planes forming the same obtuse angles with each other. Advantageously, the inner surface of the coupling nose is formed by two plane protruding surfaces defining an obtuse angle with each other, whereas that surface of the confining web which faces the transverse web is formed by two plane confining surfaces forming the same obtuse angle with each other but complementary to the other obtuse angle so that the first mentioned two surfaces have the last mentioned two surfaces nested therein.

Referring now to the drawings in detail, and FIGS. 1-3 thereof in particular, the coupling member illustrated therein comprises a relatively wide transverse web 1, a shank 2 integral with and protruding backwardly from the transverse web 1, and a flange 3 rearwardly of the shank 2. Shank 2 and flange 3 serve as holding means for holding the coupling in a coupling bearing (not shown) of a freight or passenger car, a pressure spring (not shown) pressing against the flange 3 holding the coupling hook in its central position. Connected to one end of the transverse web 1 and at a right angle thereto there is provided a longitudinal web 4, and connected to the latter at a right angle to the longitudinal vehicle axis there is provided a coupling nose 5 with an outwardly extending edge 6 forming the line of intersection of two inclined surfaces. Connected to that end of nose 5 which is remote from the longitudinal web 4 is a relatively short and narrow confining web 7. Also connected to the transverse web 1 is a decoupling pin 8.

3

According to the embodiment illustrated in FIGS. 1-3, the inner surface of the coupling nose 5 is formed by two protruding surfaces 9, 9' forming an obtuse angle with each other. Corresponding plane surfaces 10 and 10' form an angle with each other which is complementary to the angle formed by the surfaces 9, 9' so that in engaged position of two coupling members the surfaces 9, 9' will nest in the surfaces 10, 10'.

As mentioned above, in engaged position of two coupling members as illustrated in FIGS. 1 to 3, the surfaces 10, 10' of one coupling member engages the surfaces 9, 9' of the other coupling member so that an accidental disengagement of the coupling members from each other is practically impossible or at least made considerably more difficult than is the case with heretofore known coupling members. On the other hand, the ordinary coupling and uncoupling when moving one of the coupling hooks upwardly is not impaired or affected by the coupling members according to the invention.

FIG. 4 shows a slightly modified coupling member according to the invention which differs from that of FIGS. 1-3 in that the coupling nose 5 has its inner surface defined by two plane surfaces 11 and 11' forming a hollow with each other, while correspondingly the confining web 7 has two surfaces 12, 12' protruding in the direction toward the transverse web 1.

Similarly, the embodiments of FIGS. 5 and 6 differ from the embodiments of FIGS. 1-4 with regard to the interengaging surfaces. More specifically, FIG. 5 has two inversely curved surfaces 13 and 14 while the embodiment of FIG. 6 has two inversely curved surfaces 15 and 16. These inversely curved surfaces of FIGS. 5 and 6 engage each other in the manner similar to that described in FIGS. 1-4.

It is, of course, to be understood that the present invention is, by no means, limited to the particular constructions shown in the drawings, but also comprises any modifications within the scope of the appended claims.

What I claim is:

1. A coupling unit for toy and model railroads, which consists of a single integral piece having a holding portion and a hook portion arranged adjacent said holding portion; said hook portion comprising a relatively wide transverse web, and a longitudinal web extending at least approximately at an angle of 90° with regard to said transverse web, and a coupling nose member extending transverse to said longitudinal web in spaced relationship to said transverse web and having its opposite side provided

4

with tapered surface means; that end of said coupling nose member which is remote from said longitudinal web being provided with a relatively short and narrow confining wall member having its relatively narrow side facing said transverse web, one of said nose member and confining wall member having a hollow surface contour facing said transverse web and the other member having a corresponding protruding surface contour likewise facing said transverse web and fitting complementary into said hollow surface contour, the hollow surface contour of one of said members being formed by two surfaces forming an obtuse angle with each other, and the corresponding surface contour of the other member being formed by two surfaces forming with each other an angle supplementing said obtuse angle to 360°.

2. A coupling unit for toy and model railroads, which consists of a single integral piece having a holding portion and hook portion arranged adjacent said holding portion; said hook portion comprising a relatively wide transverse web, and a longitudinal web extending at least approximately at an angle of 90° with regard to said transverse web, and a coupling nose member extending transverse to said longitudinal web in spaced relationship to said transverse web and having its opposite side provided with tapered surface means; that end of said coupling nose member which is remote from said longitudinal web being provided with a relatively short and narrow confining wall member having its relatively narrow side facing said transverse web, one of said nose member and confining wall member having a hollow surface contour facing said transverse web and the other member having a corresponding protruding surface contour likewise facing said transverse web and fitting complementary into said hollow surface contour, one of said members having a concave surface contour facing said transverse web, and the other one of said members having a convex surface contour fitting into said concave surface contour.

References Cited

UNITED STATES PATENTS

Re. 24,354	9/1957	Hannapel	46-216 X
3,338,429	8/1967	Zetzsche	46-216 X
3,469,713	9/1969	Edwards	46-216 X
3,518,790	7/1970	Zamarra	46-216

LOUIS G. MANCENE, Primary Examiner

D. L. WEINHOLD, Assistant Examiner