

(19) World Intellectual Property Organization
International Bureau



(43) International Publication Date
2 July 2009 (02.07.2009)

PCT

(10) International Publication Number
WO 2009/082341 A1

(51) International Patent Classification:
A61M 15/00 (2006.01) F15D 1/00 (2006.01)

(21) International Application Number:
PCT/SE2008/051488

(22) International Filing Date:
18 December 2008 (18.12.2008)

(25) Filing Language: English

(26) Publication Language: English

(30) Priority Data:
61/015,383 20 December 2007 (20.12.2007) US

(71) Applicant (for all designated States except US): AS-
TRAZENECA AB [SE/SE]; S-151 85 Södertälje (SE).

(72) Inventor; and

(75) Inventor/Applicant (for US only): LASTOW, Orest
[SE/SE]; AstraZeneca R & D Lund, S-221 87 Lund (SE).

(74) Agent: ASTRAZENECA AB; AstraZeneca Intellectual
Property, S-151 85 Södertälje (SE).

(81) Designated States (unless otherwise indicated, for every
kind of national protection available): AE, AG, AL, AM,
AO, AT, AU, AZ, BA, BB, BG, BH, BR, BW, BY, BZ, CA,
CH, CN, CO, CR, CU, CZ, DE, DK, DM, DO, DZ, EC, EE,
EG, ES, FI, GB, GD, GE, GH, GM, GT, HN, HR, HU, ID,
IL, IN, IS, JP, KE, KG, KM, KN, KP, KR, KZ, LA, LC, LK,
LR, LS, LT, LU, LY, MA, MD, ME, MG, MK, MN, MW,
MX, MY, MZ, NA, NG, NI, NO, NZ, OM, PG, PH, PL, PT,
RO, RS, RU, SC, SD, SE, SG, SK, SL, SM, ST, SV, SY, TJ,
TM, TN, TR, TT, TZ, UA, UG, US, UZ, VC, VN, ZA, ZM,
ZW.

(84) Designated States (unless otherwise indicated, for every
kind of regional protection available): ARIPO (BW, GH,
GM, KE, LS, MW, MZ, NA, SD, SL, SZ, TZ, UG, ZM,
ZW), Eurasian (AM, AZ, BY, KG, KZ, MD, RU, TJ, TM),
European (AT, BE, BG, CH, CY, CZ, DE, DK, EE, ES, FI,
FR, GB, GR, HR, HU, IE, IS, IT, LT, LU, LV, MC, MT, NL,
NO, PL, PT, RO, SE, SI, SK, TR), OAPI (BF, BJ, CF, CG,
CI, CM, GA, GN, GQ, GW, ML, MR, NE, SN, TD, TG).

Published:
— with international search report

(54) Title: DEVICE AND METHOD FOR DEAGGREGATING POWDER 854

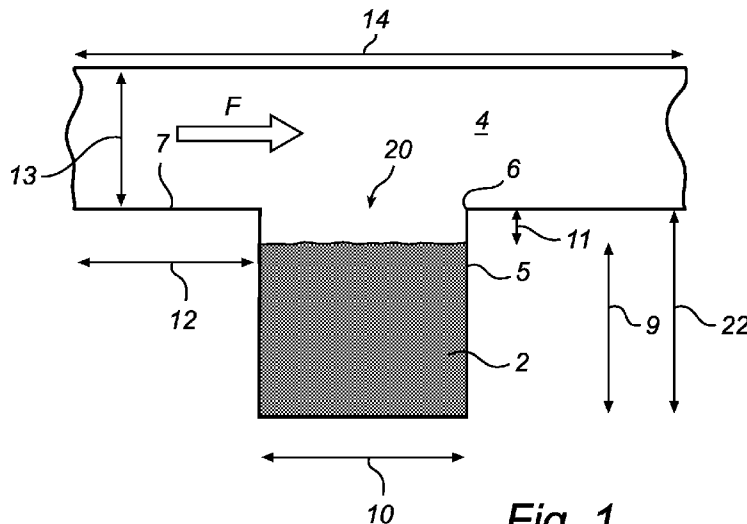

Fig. 1

(57) Abstract: The invention relates to a device (1) for inhalation of at least one air stream carrying a dose of medicament powder (2). The device comprises a flow passage (4) passing a powder-containing cavity (5). A part of said flow passage (4) propagates along a flat surface region (7). The flat surface region (7) comprises a cavity opening (20) into said powder-containing cavity (5). The passing of an air stream along said flat surface region (7) and outside said cavity (5) generates an eddy in the cavity (5) and the generated eddy contributes to deaggregation of the powder (2) in said cavity (5) and emptying of the powder (2) from said cavity (5). Furthermore, the invention relates to the use of a shear driven cavity principle on such a device (1) and a method of releasing medicament powder (2).

WO 2009/082341 A1

DEVICE AND METHOD FOR DEAGGREGATING POWDER 854

Field of the invention

The invention relates to a device for enabling deaggregation during dispensing of at least one air stream carrying a dose of medicament powder, the device comprising a flow
5 passage passing a powder-containing cavity. Furthermore, the invention relates to a method of deaggregating medicament powder.

Background of the invention

There are many devices for administering powdered medicaments to the lungs, which
10 employ propellants, such as compressed gases, e.g. air, or liquefied gas propellants, to dispense and disperse the medicament.

There are also a number of known breath actuated inhalation devices for administering powdered medicaments to the lungs, which have mouthpieces through which the
15 medicament is inhaled. British Patent Specification Nos. 1 521 000, 1 520 062, 1 472 650 and 1 502 150 disclose more complex devices in which a complete capsule is inserted into the device thus ensuring no spillage of medicament prior to inhalation, and access to the medicament is gained by piercing the capsule or cutting it in half, inside the dispensing device. On inhalation the air flows into or through the capsule and the powder within is
20 released into the air stream and flows towards the mouth.

U.S. Patent Specification No. 4 210 140 discloses a device in which access to the powdered medicament is gained by pulling the halves of the capsule apart so that the medicament is emptied to a suitable position for entrainment in the airflow caused by
25 inhalation.

US Patent No. 6,655,381B2 relates to a pre-metered dose assembly for consistently supplying precise doses of medicament for a breath-actuated dry powder inhaler. The assembly includes a cap defining a dry powder delivery passageway for providing air to a
30 dry powder supply port of a swirl chamber of a breath-actuated dry powder inhaler, and a

magazine including a plurality of reservoirs for holding pre-metered doses of dry powder. One of the magazine and the cap is movable with respect to the other of the magazine and the cap for sequentially positioning the reservoirs within the delivery passageway of the cap. A breath-induced low pressure at an outlet port of the inhaler causes an air flow
5 through the dry powder delivery passageway of the assembly and into the dry powder supply port that entrains dry powder from the reservoir positioned in the passageway for inhalation by a patient using the inhaler. The passageway is provided with a venturi in the passageway by the reservoir to create a flow through the reservoir and bring the powder there from.

10

In spite of the numerous prior art devices there is a need for a device, which is simple to operate, and efficient in administering powdered medicaments into the alveolar region of the lungs. Hence, it is a further object of the present invention to enable the medicament powder to be deaggregated before being administered by the device. In addition to the
15 above mentioned methods of enabling deaggregation in the prior art, there exist various ways of enabling deaggregation by vibrating, shaking or providing alternative obstacles in the flow passage etc. It is common to strive for a deaggregation that makes a significant amount of the powder particles to be in accordance with a desired size and weight. This is often referred to as a classifying of the powder particles. These prior art deaggregation
20 devices may result in contamination of the downstream flow passage since medicament powder may accumulate in the downstream region of the device e.g. by certain alternative obstacles. It is of course desirable to reduce or avoid the risk of administering an inaccurate amount of medicament powder.

25 Summary of the invention

The above-mentioned object is achieved by providing a device of the kind defined in the preamble of claim 1, characterized in that a part of said flow passage propagates along a flat surface region, said flat surface region comprising an opening into said powder-
containing cavity and that the passing of an air stream along said flat surface region and
30 outside said cavity generates an eddy in the cavity and the generated eddy contributes to

deaggregation of the powder in said cavity and emptying of the powder from said cavity. The flow passage is arranged to enable guiding of the air stream passing the opening of the cavity on the outside of the cavity opening thereof.

It is found that the build up of an eddy in the cavity will allow for deaggregation.

5 Advantageously, the device is an inhaler. It may be suitable for single as well as multidose type inhalers.

Advantageously, the cavity is brick-shaped and the cavity opening has a rim where the sides of the cavity transcend (change) into the flow passage flat surface region. Thus, the flat surface region may continue both upstream and downstream of the cavity opening. 10 Accordingly, the air stream, when passing the cavity in the flow passage, may flow in parallel with a plane coinciding with the rim of the cavity opening in the flow passage. This is what creates a shear driven cavity flow in the device. More in detail, the flow passage is arranged so that the flow is directed in parallel with the plane coinciding with the rim of the cavity opening in the flow passage where the cavity is located. The sides of the cavity may transcend perpendicularly in the flat surface region. 15

Since the eddy is developing efficiently when it describes a cylindrical movement pattern it is advantageous that the cavity/cavities in question is/are shaped to allow a cylindrical wind flow pattern within the cavity. It is acknowledged that a cavity is a space in a 20 structure with one opening to the surrounding environment. More in particular, the cavity may have a length in the flow direction (F) of the flow passage which is in the range of 65% to 135% of the cavity depth, such as in the range of 85% to 115% of the cavity depth, for instance in the range of 95% to 105% of the cavity depth. Hence, suitably, the cavity depth does not exceed the value of the length in the flow direction in terms of dimension. 25

Suitably, at least one cavity side, when taken in a cross section of the cavity as seen from above when the device is in the normal use condition and the opening of the cavity is facing upwards, has a width of the cavity which is in the range of 35% to 135% of the length, of the cavity, as seen in the propagating direction of the flow passage, such as in the 30

range of 45% to 115% of the length of the cavity, for instance in the range of 50% to 100% of the length of the cavity. Consequently, a suitable shape of the cavity cross sectional shape as seen from above is a rectangular shape.

5 Moreover, the cavity depth and cavity length relation may be such that they form a substantially quadratic cross section. Hence, the inner corners of the cavity are essentially sharp. The edges of the cavity that propagates transverse to the air stream direction and are present in the bottom of the cavity may have a slightly curved shape in order to provide some guidance in the rotational movement of the generated eddy.

10

The cavity is provided with a headspace between powder top and the cavity rim; the headspace is at least 1 mm. The distance from the top of the cavity to the top of the particle bed in an initial condition may be 1 mm or more than 1 mm. This distance is referred to as the headspace of the cavity. A headspace of e.g. 3 mm is sufficient for the conditions in the present device but depends also on the total cavity depth. Possibly, the headspace may vary in between 10 to 80% of the cavity depth provided that the shape of the cavity is adapted for deaggregation in accordance with the present invention.

15

It is also found that the mass flow rate of the device is fairly insensitive to the depth of the cavity. The extent of the headspace may be between 15% and 35% of the cavity depth and the cavity depth, from rim to bottom of a brick-shaped cavity, is between 4 and 10 mm, such as about 5 mm.

20

It is realized that the design of the present device provides for use of a phenomenon denoted as shear driven cavity principle during deaggregation of the powder in the cavity and emptying operation of the powder there from. Suitably, the flow passage is arranged to follow a generally horizontal line from an inlet port chamber to a mouthpiece when the device is positioned for normal operation.

25

The shear driven cavity is a model for flow in a cavity where the upper boundary moves in a desired flow direction, and thus causes a rotation in the cavity. The flow occurs at a

30

Reynolds number which is likely higher than 4000 so the upper boundary flow may be assumed to be turbulent in general cases. The patterns during this process are quite complex. In order to support the shear driven cavity flow phenomenon by the cavity the opposing side surfaces of the flow passage are arranged with a broadening propagation in relation to one another. The flow passage may be formed with a constant distance between upper and lower flat surface region in the upstream region in relation to the cavity.

Furthermore, it is desirable that the flow passage in the downstream region in relation to the cavity is formed with the same distance as the upstream region. The cross sectional shape of the flow passage in the cavity region is also formed in the same manner. The cross sectional shape of the flow passage may be rectangular with dimensions ranging between 2 to 5 mm.

Rectangular cavities are attractive provided they have an appropriate depth. For these cavities, the emptying time and the wall deposition factor is predicted to increase as the depth increases. The deaggregation potential is predicted to decrease as the depth increases beyond 5 mm, but a local maximum is found for depths near 4 mm. The depth is also important for cavities with inclined walls.

The orientation of the cavity with respect to the flow passage is found to have a significant effect on the emptying time and the deaggregation potential. The cavity depth, the cavity fillet radii, and the channel height are predicted to have only a minor impact on the emptying time and the deaggregation potential. An inspection of the flow behavior suggests that deaggregation is promoted by devices for which an inclination angle $\alpha > 0$ because the cavity affects the air stream in such a way that the powder particles that are about to escape from the cavity are more likely to re-enter the cavity. The particles that fail to escape from the cavity instead impact on the downstream wall of the cavity, which causes deaggregation. Obviously, since particles are less likely to escape the cavity for devices with $\alpha > 0$, the emptying time is longer.

Suitably, it is also provided a device wherein a cavity structure holder, for a cavity structure having a plurality of cavities containing respective doses of powder, is arranged thereto. The cavity structure holder forms part of at least one of the side portions of the flow passage. It is anticipated that the shape of the flow passage allows for a simple design which in turn allows for use of less elements leading to facilitate manufacturing process. Advantageously, a plurality of cavities is integrally formed in said cavity structure.

Moreover, it is a further benefit of the present invention to provide a seal component, such as a foil, which is releasably covering said cavity opening in a pre-inhaling condition. Advantageously, the seal component of the cavity opening is releasable upon breath actuation. The discovery of a device and a method for efficient deaggregation within the cavity allows for a simple design of the outlet leading to a significantly reduced risk for medicament powder to get caught in the downstream area. Thus, it is realized that the administration of medicament powder may be performed in a secure manner with respect to e.g. dose amount.

It is also described a method for deaggregating a medicament powder during dispensing of medicament powder. It is thus disclosed a method for deaggregating a medicament powder in an inhalation device. The method of providing of at least one air stream carrying a dose of medicament powder comprises bringing an air stream to flow straight along a part of a flow passage propagating along a flat surface region, said flat surface region comprising an opening into a powder-containing cavity, and passing the air stream outside said cavity to generate an eddy in the cavity, the eddy contributing to the deaggregation of the powder in the cavity and emptying of the powder from said cavity.

Since the eddy is developing efficiently when it describes a cylindrical movement pattern it is advantageous that the cavity/cavities in question is/are shaped to allow a circular or rather cylindrical wind flow pattern within the cavity. The cylindrical flow pattern in the cavity would be developed around an axis located transverse the flow direction and in the

middle of the cavity when the device is held in normal operation condition. It is acknowledged that a cavity is a space in a structure with one opening to the surrounding environment. More in particular, the cavity may have a length in the flow direction (F) of the flow passage which is in the range of 65% to 135% of the cavity depth, such as in the range of 85% to 115% of the cavity depth, for instance in the range of 95% to 105% of the cavity depth. Hence, suitably, the cavity depth does not exceed the value of the length in the flow direction in terms of dimension.

It is common in the art of deaggregation to strive after that powder particles are deaggregated to a desired size and possibly mass weight. By using these proportions the deaggregation due to shear driven cavity in the cavity will be performed efficiently. This means that larger particles may not leave the cavity as easy as smaller powder particles. Thus, larger particles will be subject to some additional loops in the cavity and thus increased deaggregation. Once the larger powder particles have been deaggregated to a suitable size they will leave the cavity. It is one of the benefits of the shear driven cavity principles used in this environment that a classifying effect is enabled.

Consequently, it is found that a suitable shape of the cavity, in any cross section as seen from the side, is an essentially quadratic shape. The inner corners of the cavity are advantageously sharp. The edges of the cavity that propagates transverse to the air stream direction and are present in the bottom of the cavity may have a slightly curved shape in order to provide some guidance in the rotational movement of the generated eddy.

Suitably, at least one cavity side, when taken in a cross section of the cavity as seen from above when the device is in the normal use condition and the opening of the cavity is facing upwards, has a width which is in the range of 35% to 135% of the length in the propagating direction of the flow passage cavity for allowing generation of an eddy with the ability to perform deaggregation and emptying of a cavity. For instance, the cavity opening may have a width in the cavity opening in the range of 45% to 115% of the length of the cavity, such as in the range of 50% to 100% of the length of the cavity.

The medicament-containing cavity may contain various drugs and/or bioactive agents. The bioactive agent may be selected from any therapeutic or diagnostic agent. For example it may be from the group of antiallergics, bronchodilators, bronchoconstrictors, pulmonary
5 lung surfactants, analgesics, antibiotics, leukotrine inhibitors or antagonists, anticholinergics, mast cell inhibitors, antihistamines, anti-inflammatory, antineoplastics, anaesthetics, anti-tubercular, imaging agents, cardiovascular agents, enzymes, steroids, genetic material, viral vectors, antisense agents, proteins, peptides and combinations thereof.

10

Examples of specific drugs which can be incorporated in the medicament containing cavity according to the invention include mometasone, ipratropium bromide, tiotropium and salts thereof, salmeterol, fluticasone propionate, beclomethasone dipropionate, reproterol, clenbuterol, rofleponide and salts, nedocromil, sodium cromoglycate, flunisolide,
15 budesonide, formoterol fumarate dihydrate, SymbicortTM (budesonide and formoterol), terbutaline, terbutaline sulphate, salbutamol base and sulphate, fenoterol, 3-[2-(4-Hydroxy-2-oxo-3H-1,3-benzothiazol-7-yl)ethylamino]-N-[2-[2-(4-methylphenyl)ethoxy]ethyl]propane-sulphonamide, hydrochloride. All of the above compounds can be in free base form or as pharmaceutically acceptable salts as known in
20 the art.

Combinations of drugs may also be employed, for example formoterol/budesonide; formoterol/fluticasone; formoterol/mometasone; salmeterol/fluticasone; formoterol/tiotropium salts; zafirlukast/formoterol, zafirlukast/budesonide;
25 montelukast/formoterol; montelukast/budesonide; loratadine/montelukast and loratadine/zafirlukast.

Further combinations include tiotropium and fluticasone, tiotropium and budesonide, tiotropium and mometasone, mometasone and salmeterol, formoterol and rofleponide,
30 salmeterol and budesonide, salmeterol and rofleponide, and tiotropium and rofleponide.

Brief Description of the Drawings

The present invention will now be described, for exemplary purposes, in more detail by way of embodiments and with reference to the enclosed drawings, in which:

5 Fig. 1 is a schematic cross sectional view of a flow passage region of at least one example embodiment,

Fig. 2 is a schematic cross sectional view of an alternative flow passage region of an alternative embodiment,

10 Figs. 3a-3d disclose an inhalation sequence in principle by means of a schematic perspective view in cross section,

Fig. 4 discloses a side view of an inhalation device according to at least one example embodiment, and

Fig. 5 illustrates an exploded partial view of the inhalation device disclosing the cavity structure holder more in detail.

15

Detailed Description of the Drawings

At least one example embodiment of the present invention is an inhalation device from which a user may inhale consecutive doses of medicament in the form of dry powder. Such an inhalation device is illustrated in fig. 4. The device 1 includes a housing and a
20 mouthpiece 3. The mouthpiece 3 may be uncovered by linear movement of the mouthpiece cover. The mouthpiece cover according to a second embodiment is pivotally supported by the housing of the device 1.

The device 1 is used for providing medicament powder and part of its interior is disclosed
25 in fig. 5. Inside the housing there is provided a cavity structure 18 containing a plurality of cavities 5. In accordance with the illustrated embodiment the cavity structure 18 is positioned in a cavity holder 19. The cavity structure 18 may be provided with a plurality of cavities 5 in an annular pattern. Moreover, the cavity structure 18 in accordance with the illustrated embodiment is ring-shaped with a comparatively large hole in the centre thereof.

30

The cavity 5 is brick-shaped and the cavity opening has a rim 6 where the sides of the cavity 5 transcend into the flow passage flat surface 7 region. The eddy is developing efficiently when it describes a circular movement pattern. It is advantageous that the cavity/cavities 5 in question is/are shaped to allow a cylindrical wind flow pattern within the cavity 5. The cylindrical flow pattern in the cavity would be developed around an axis located transverse the flow direction and in the middle of the cavity when the device is held in normal operation condition. The sides of the cavity may transcend perpendicularly in the flat surface region of the cavity structure 18 which in turn is aligned with the flat surface of the cavity holder 19 providing for an appropriate flow direction in the flow passage (not shown in fig. 5).

Now, with reference to fig. 1 the overall function of the device 1 according to a at least one example embodiment of the invention will be described in more detail. Part of the flow passage 4 propagates along a flat surface region 7. The flat surface region 7, which forms the bottom of the flow passage 4 when the device 1 is in its intended use condition, comprises a cavity opening 20 into said powder-containing cavity 5. The passing of an air stream in the flow direction (F) along said flat surface region 7 and outside said cavity 5 generates an eddy in the cavity 5 and the generated eddy contributes to deaggregation of the powder 2 in said cavity 5. The powder particles are brought against the sides within the cavity 5 when the shear driven cavity eddy is generated. When the powder particles hit the sides of the cavity 5 they become deaggregated and thus appropriate for administration. Furthermore, the generated eddy contributes to the emptying of the powder 2 from said cavity 5.

More in particular the cavity 5 and cavity opening 20 each have a length 10 in the flow direction (F) of the flow passage 4 which is in the range of 65% to 135% of said cavity depth 22. More suitable, the cavity 5 and cavity opening 20 each have a length 10 in the flow direction (F) of the flow passage which is in the range of 85% to 115% of the cavity depth 22, such as in the range of 95% to 105% of the cavity depth 22 of said cavity 5. More in detail one cavity side, when taken in a cross section of the cavity as seen from

above when the device is in the normal use condition and the opening of the cavity is facing upwards, has a width 8 in the propagating direction of the flow passage 4 which is in the range of 35% to 135% of the length 10 of the cavity 5, such as in the range of 45% to 115% of the length 10 of the cavity 5, for instance in the range of 50% to 100% of the length 10 of the cavity 5.

The distance from the top of the cavity 5 to the top of the powder particle bed in an initial condition may, for instance, be 1 mm or more than 1 mm. This distance is referred to as the headspace 11 of the cavity. The cavity 5 is provided with a headspace 11 between powder top and the cavity rim 6; the headspace 11 is at least 1 mm. A headspace 11 sufficient for the conditions for inhalation devices 1 according to the present invention. A headspace ranging in between 1-3 mm would be sufficient for the conditions in the present inhaler but depends also on the total cavity depth. Possibly, the headspace may vary in between 10 to 80% of the cavity depth provided that the shape of the cavity is adapted for deaggregation in accordance with the present invention. It is also found that the mass flow rate of the device 1 is fairly insensitive to the depth 22 of the cavity, at least following an initial induction period of approximately 5 - 10 ms. The extent of the headspace 11 may be between 10 and 35 % of the cavity depth 22 and the cavity depth 22, from rim 6 to bottom of a brick-shaped cavity 5, is between 4 and 10 mm.

Consequently, a suitable cross sectional shape of the cavity 5, as seen from the side, is a quadratic shape. The inner corners of the cavity are essentially sharp. The edges 16, 17 of the cavity 5 that propagates transverse to the air stream direction and are present in the bottom of the cavity 5 may have a slightly curved shape (not shown in fig. 1) in order to provide some guidance in the rotational movement of the generated eddy.

In fig. 2 a second embodiment of the present invention is disclosed. The sides of the cavity 5 are positioned with an angle (α) in relation to a normal direction to the flow direction (F). The rim 6 of the cavity opening 20 will still be aligned with a plane parallel to the flow direction of the air stream in the flow passage region 4 by the cavity 5. The inclination of

the side walls in relation to the flow passage 4 will make it more difficult for the generated eddy to provide for dispensing of powder from the cavity 5. Hence, a design in accordance with the second embodiment will increase the time during which the medicament powder 2 is subject to wall contact impact and hence the deaggregation time period may be
5 extended. On the other hand the emptying time will, in analogy with the above explained also be longer for the second embodiment compared to a similar type but with a design in accordance with fig. 1. It is also found that the flow in the device is qualitatively similar for most flow rates.

10 Computational studies with brick- and capsule shaped cavities 5 were performed and it was found that a brick shaped cavity 5 showed more promising results than a capsule shaped cavity. The rate of emptying is found to be slightly slower for the device 1 with a capsule shaped cavity. While the flow in the brick shaped cavity 5 is found to be substantially two-dimensional, the flow in the capsule shaped cavity is found to be three-dimensional. The
15 three-dimensional flow in the capsule shaped cavity is found to result in a greater concentration of particles at and near the centerline down stream of the cavity. The major difference, however, is in the capacity of enabling a cylindrical flow pattern leading in turn to an appropriate deaggregation. It is anticipated that the shape of the cylindrical capsule does not allow for a build up of a cylindrical flow pattern.

20

Now continuing, with reference to fig. 2 and the shape of the cavity 5. The bottom most edges 16, 17, of a substantially brick shaped cavity, located in the transverse direction in relation to the flow direction (F) may have a curved shape. The first edge 17 in the more downstream position in relation to the second edge 16 has a shorter radius than said second
25 edge 16. The first arrow 9 indicates how the cavity powder depth is measured. The headspace 11 is the distance between the top of the dry powder and the rim 6 of the cavity 5. The length 10 of the cavity is also illustrated in fig. 2 with an arrow carrying reference number 10.

Continuing to figs. 3a-3d the dispensing principle in accordance with at least one example embodiment of the invention is further explained. It is realized that the design of the present device 1 provides for use of a phenomenon denoted as shear driven cavity principle during deaggregation of the powder 2 in the cavity 5 and emptying operation of the powder 2 there from. Suitably, the flow passage 4 is arranged to follow a generally horizontal line from an inlet port to a mouthpiece when the device 3 is positioned for normal operation. The flow passage is arranged to guide the air stream passing the opening of the cavity on the outside of the cavity opening thereof.

10 In fig. 3a it is disclosed a cavity 5 which is filled with powder 2 with a suitable headspace 11. An air stream along the flow passage 4 is initiated in the flow direction (F) and emptying of the cavity 5 starts. Moving to fig. 3b in which some of the powder 2 has left the cavity 5. The build up of an eddy air stream in the cavity 5 has begun and it is seen that the cavity 5 is emptied in the downstream region and further upstream when moving to fig 15 3c. The time period elapsed from the situation in fig. 3a to that in fig. 3d when the emptying of the cavity 5 is completed depends of course on the size and magnitude of flow, depth, powder composition, powder depth, headspace etc. In at least one example embodiment the emptying time including deaggregation is from 30 ms. For instance, the emptying time including deaggregation may be 500 ms.

20

The shear driven cavity is a model for flow in a cavity 5 where the upper boundary moves in a desired flow direction (F), and thus causes a rotation of gas/air in the cavity 5. The flow occurs at a Reynolds number which is likely higher than 4000 so the upper boundary flow may be assumed to be turbulent in general cases. The patterns during this process are quite complex. The opposing side surfaces of the flow passage 4 are arranged with a broadening propagation in relation to one another in the flow direction. A device 25 comprising a disc in accordance with the embodiment of fig. 5 which has 60 cavities will have side walls of the flow passage which broadens at an angle of 4 degrees in relation to a centerline of the flow passage.

30

In an alternative embodiment in which the disc is provided with 30 cavities the side walls of the flow passage broadens at an angle of 12 degrees in relation to a centerline of the flow passage. The flow passage 4 may be formed with a constant distance between upper and lower flat surface region in the upstream region in relation to the cavity 5.

5 Furthermore, it is desirable that the flow passage 4 in the downstream region in relation to the cavity 5 is formed with the same distance as the upstream region. The cross sectional shape of the flow passage 4 in the cavity region is also formed in the same manner. The cross sectional shape of the flow passage 4 may be rectangular with dimensions ranging between 1 to 5 mm.

10

According to a third embodiment of the invention the device is a single inhalation device containing one cavity with medicament powder.

15

Rectangular cavities 5 are attractive provided they have an appropriate depth. For these cavities, the emptying time and the wall deposition factor is predicted to increase as the depth increases. The deaggregation potential is predicted to decrease as the depth increases beyond 5 mm, but a local maximum is found for depths near 4 mm. The depth is also important for cavities with inclined walls.

20

The orientation of the cavity with respect to the flow passage is found to have a significant effect on the emptying time and the deaggregation potential. The cavity depth, the cavity fillet radii, and the channel height are predicted to have only a minor impact on the emptying time and the deaggregation potential. An inspection of the flow behavior suggests that deaggregation is promoted by devices 1 for which $\alpha > 0$ because the cavity 5 affects the air stream in such a way that the powder 2 particles that are about to escape from the cavity are more likely to re-enter the cavity. The particles that fail to escape from the cavity 5 instead impact on the downstream wall of the cavity 5, which causes deaggregation. Since particles are less likely to escape the cavity for devices with $\alpha > 0$, the emptying time is longer.

30

It is realised that the features of the above presented embodiments is not a complete description of all aspects of the invention and further combinations of features from different embodiments are conceivable within the claimed scope of protection. Hence, it is possible to combine various features with different embodiments within the claimed scope
5 for enabling further aspects of the invention.

CLAIMS

1. A device (1) for enabling deaggregation during dispensing of at least one air stream
5 carrying a dose of medicament powder (2), the device comprising a flow passage (4)
passing a powder-containing cavity (5),

 c h a r a c t e r i z e d in that a part of said flow passage (4) propagates along a
flat surface region (7), said flat surface region (7) comprising an opening (20) into said
powder-containing cavity (5),

10 and in that the passing of an air stream along said flat surface region (7) and outside
said cavity (5) generates an eddy in the cavity (5) and the generated eddy contributes to
 deaggregation of the powder (2) in said cavity (5) and
 emptying of the powder (2) from said cavity (5).

15 2. The device (1) according to claim 1, wherein said cavity (5) is brick-shaped and the
cavity opening (20) has a rim (6) where the sides of the cavity (5) transcends into the flow
passage (4) flat surface region (7).

3. The device (1) according to any one of claims 1-2, wherein the cavity (5) has a length
20 (10) in the flow direction (F) of the flow passage (4) which is in the range of 65% to 135%
of the powder depth (9) of said cavity (5), such as in the range of 85% to 115% of the
powder depth (9) of said cavity (5), such as in the range of 95% to 105% of the powder
depth (9) of said cavity (5).

4. The device (1) according to any one of claims 1-3, wherein one side of the cavity, in a cross section of the cavity as seen from above when the device (1) is in the normal use condition and the opening (20) of the cavity (5) is facing upwards, has a width (8) which is in the range of 35% to 135% of the length (10) of the cavity (5) in the propagating
5 direction of the flow passage (4), such as in the range of 45% to 115% of the length (10) of the cavity (5), such as in the range of 50% to 100% of the length (10) of the cavity (5).

5. The device (1) according to any one of claims 1-4, wherein the cavity (5) is provided with a headspace (11) between powder top and the cavity rim (6), the headspace (11) being
10 at least 1 mm.

6. The device (1) according to any one of claims 1-5, wherein the flow passage (4) is arranged to follow a generally horizontal line from an inlet port chamber to a mouthpiece (3) when the device (1) is positioned for normal operation.
15

7. The device (1) according to any one of claims 1-6, wherein the opposing side surfaces of the flow passage (4) being arranged with a broadening propagation in relation to one another as seen in the flow direction (F).

20 8. The device (1) according to any one of claims 1-7, wherein a cavity structure holder (19), for a cavity structure (18) having a plurality of cavities (5) containing respective doses of powder (2), is arranged thereto, wherein, optionally, the cavity structure holder (19) forms part of at least one of the side portions of the flow passage (4).

25 9. The device according to claim 8, wherein a plurality of cavities (5) is integrally formed in said cavity structure (18).

10. Use of a shear driven cavity principle for deaggregating medicament in a device according to any one of claims 1-9.

11. A method (1) for deaggregating a medicament powder (2) during dispensing of at least one air stream carrying a dose of powder (2), comprising

bringing an air stream to flow straight along a part of a flow passage (4) propagating along a flat surface region (7), said flat surface region (7) comprising an opening (20) into a powder-containing cavity (5), and

passing the air stream outside said cavity to generate an eddy in the cavity (5), the eddy contributing to the deaggregation of the powder (2) in the cavity (5) and emptying of the powder (2) from said cavity (5).

12. The method according to claim 11, in which said eddy is generated in a brick-shaped cavity (5).

13. The method according to any one of claims 11-12, in which the shear driven cavity principle is used for deaggregation operation in said cavity (4) and emptying operation of the powder (2) there from.

14. The method according to any one of claims 11-13, in which the air stream, when passing the cavity (5) in the flow passage (4), flows in parallel with a plane coinciding with the rim (6) of the cavity opening in the flow passage (4).

15. The method according to any one of claims 11-14 implemented in a device having the features defined in any one of claims 1-9.

1/3

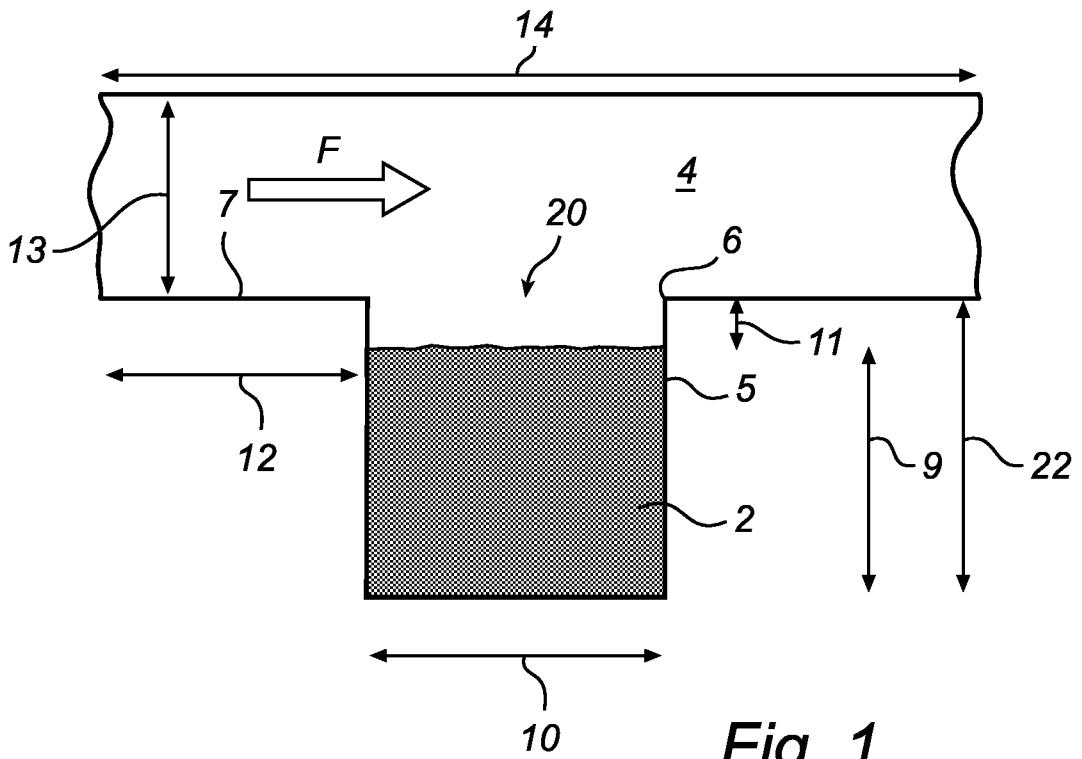

Fig. 1

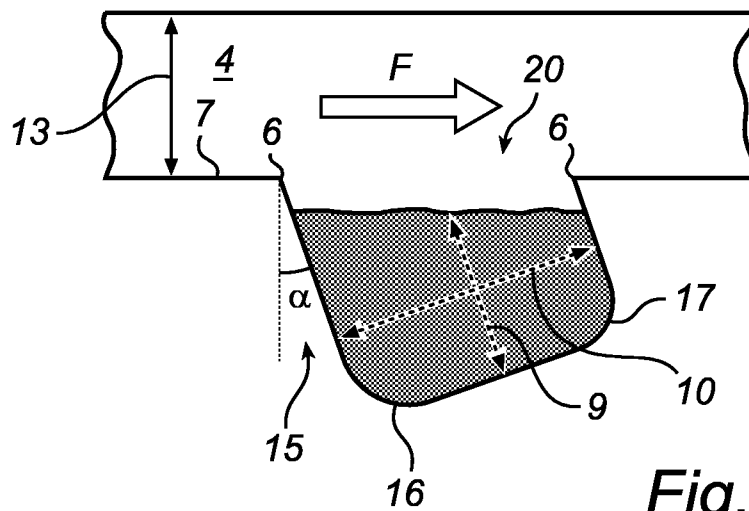

Fig. 2

2/3

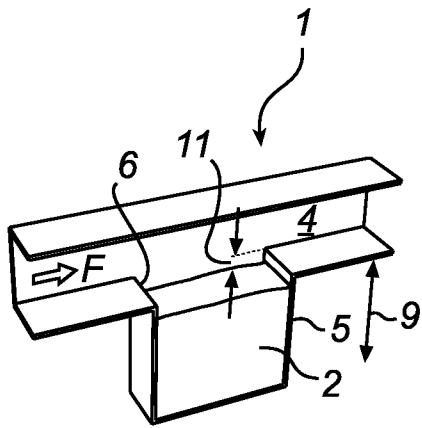

Fig. 3a

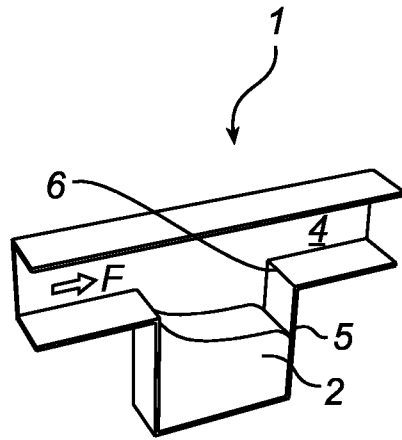

Fig. 3b

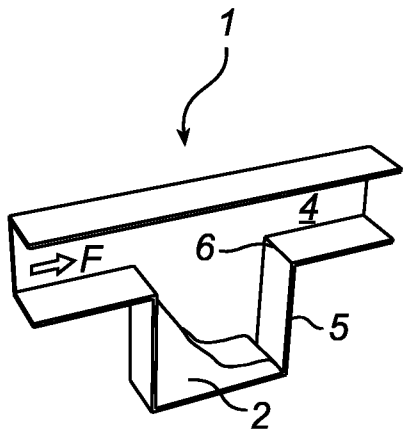

Fig. 3c

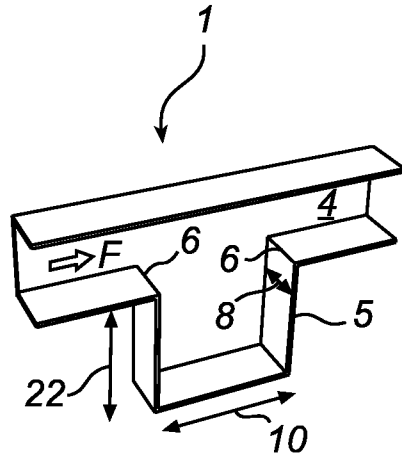

Fig. 3d

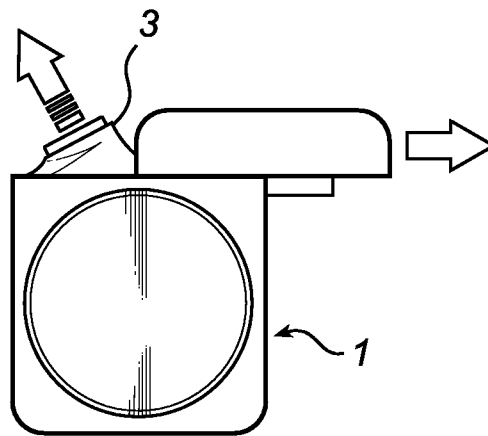

Fig. 4

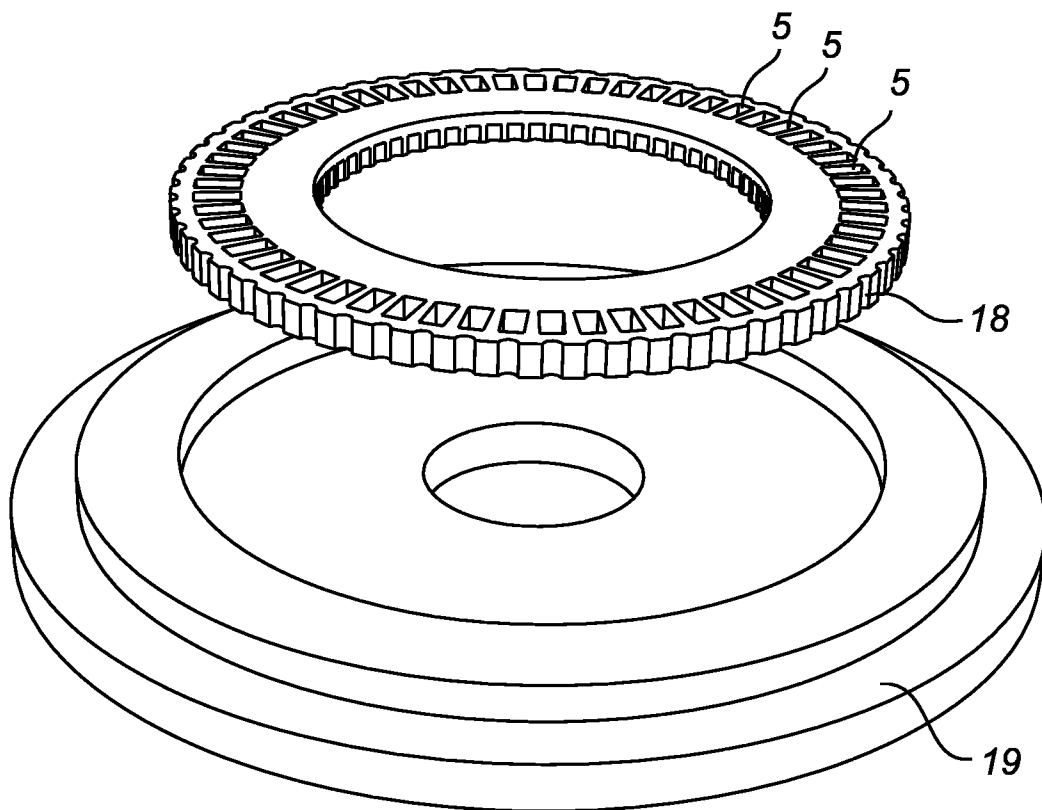

Fig. 5

INTERNATIONAL SEARCH REPORT

International application No.

PCT/SE2008/051488

A. CLASSIFICATION OF SUBJECT MATTER

IPC: see extra sheet

According to International Patent Classification (IPC) or to both national classification and IPC

B. FIELDS SEARCHED

Minimum documentation searched (classification system followed by classification symbols)

IPC: A61M, F15D, B05B

Documentation searched other than minimum documentation to the extent that such documents are included in the fields searched

SE,DK,FI,NO classes as above

Electronic data base consulted during the international search (name of data base and, where practicable, search terms used)

EPO-INTERNAL, WPI DATA, PAJ

C. DOCUMENTS CONSIDERED TO BE RELEVANT

Category*	Citation of document, with indication, where appropriate, of the relevant passages	Relevant to claim No.
A	US 20040069303 A1 (BROWN ET AL), 15 April 2004 (15.04.2004), figures 1,5, abstract, paragraphs (0014)-(0015),(0027),(0065) --	11-15
A	US 20030192539 A1 (MYRMAN), 16 October 2003 (16.10.2003), figures 17a,17b, abstract, paragraphs (0093),(0096),(0116),(0121) --	11-15
A	AU 651910 B (FRANCO DEL BON ET AL), 16 March 1993 (16.03.1993), abstract --	11-15

 Further documents are listed in the continuation of Box C. See patent family annex.

* Special categories of cited documents:

"A" document defining the general state of the art which is not considered to be of particular relevance

"E" earlier application or patent but published on or after the international filing date

"L" document which may throw doubts on priority claim(s) or which is cited to establish the publication date of another citation or other special reason (as specified)

"O" document referring to an oral disclosure, use, exhibition or other means

"P" document published prior to the international filing date but later than the priority date claimed

"T" later document published after the international filing date or priority date and not in conflict with the application but cited to understand the principle or theory underlying the invention

"X" document of particular relevance: the claimed invention cannot be considered novel or cannot be considered to involve an inventive step when the document is taken alone

"Y" document of particular relevance: the claimed invention cannot be considered to involve an inventive step when the document is combined with one or more other such documents, such combination being obvious to a person skilled in the art

"&" document member of the same patent family

Date of the actual completion of the international search

9 March 2009

Date of mailing of the international search report

09-03-2009

Name and mailing address of the ISA/
Swedish Patent Office
Box 5055, S-102 42 STOCKHOLM
Facsimile No. +46 8 666 02 86

Authorized officer

Mimmi Westman / JA A
Telephone No. +46 8 782 25 00

INTERNATIONAL SEARCH REPORT

International application No.

PCT/SE2008/051488

C (Continuation). DOCUMENTS CONSIDERED TO BE RELEVANT

Category*	Citation of document, with indication, where appropriate, of the relevant passages	Relevant to claim No.
A	US 20030015195 A1 (HAAIJE DE BOER ET AL), 23 January 2003 (23.01.2003), abstract, paragraphs (0076),(0080) --	11-15
A	US 5469843 A (HODSON), 28 November 1995 (28.11.1995), column 3, line 12 - line 26; column 4, line 58 - line 66; column 6, line 23 - line 34, abstract --	11-15
A	US 20040107963 A1 (FINLAY ET AL), 10 June 2004 (10.06.2004), figures 3-4, abstract, paragraphs (0007),(0028) --	11-15
A	DE 102005046645 B3 (BRAUNFORM GMBH), 20 July 2006 (20.07.2006), figure 4a, abstract, paragraphs (0010)-(0011),(0022)-(0023) --	11-15
A	US 5383850 A (SCHWAB ET AL), 24 January 1995 (24.01.1995), abstract -- -----	11-15

INTERNATIONAL SEARCH REPORT

International application No.
PCT/SE2008/051488

Box No. II Observations where certain claims were found unsearchable (Continuation of item 2 of first sheet)

This international search report has not been established in respect of certain claims under Article 17(2)(a) for the following reasons:

1. Claims Nos.:
because they relate to subject matter not required to be searched by this Authority, namely:

2. Claims Nos.: 1-10
because they relate to parts of the international application that do not comply with the prescribed requirements to such an extent that no meaningful international search can be carried out, specifically:

see extra sheet.

3. Claims Nos.:
because they are dependent claims and are not drafted in accordance with the second and third sentences of Rule 6.4(a).

Box No. III Observations where unity of invention is lacking (Continuation of item 3 of first sheet)

This International Searching Authority found multiple inventions in this international application, as follows:

1. As all required additional search fees were timely paid by the applicant, this international search report covers all searchable claims.
2. As all searchable claims could be searched without effort justifying an additional fees, this Authority did not invite payment of any additional fees.
3. As only some of the required additional search fees were timely paid by the applicant, this international search report covers only those claims for which fees were paid, specifically claims Nos.:

4. No required additional search fees were timely paid by the applicant. Consequently, this international search report is restricted to the invention first mentioned in the claims; it is covered by claims Nos.:

Remark on Protest

- The additional search fees were accompanied by the applicant's protest and, where applicable, the payment of a protest fee.
- The additional search fees were accompanied by the applicant's protest but the applicable protest fee was not paid within the time limit specified in the invitation.
- No protest accompanied the payment of additional search fees.

II (2)

Claim 1 describes a device for enabling deaggregation and emptying of a cavity. The device is constructed with a flow passage with a flat surface region which passes over an open cavity. Eddy currents are thus generated in the open cavity where the medicament is kept and the eddies empty the cavity and at the same time deaggregates the particles in the medicament. The subject matter of claim 1 hence describes, and seeks to protect, a standard device for the generation of shear driven cavity flow which is a well known physical phenomena.

According to Article 17 (2)(a)(i) and Rule 39.1 (i) the International Searching Authority is not required to search an invention the subject matter of which is a scientific theory. On these grounds no search or examination has been conducted for the subject matter of claims 1-10.

International patent classification (IPC)**A61M 15/00** (2006.01)**F15D 1/00** (2006.01)**Download your patent documents at www.prv.se**

The cited patent documents can be downloaded at www.prv.se by following the links:

- In English/Searches and advisory services/Cited documents (service in English) or
- e-tjänster/anförda dokument (service in Swedish).

Use the application number as username.

The password is **SUYCVNFSDP**.

Paper copies can be ordered at a cost of 50 SEK per copy from PRV InterPat (telephone number 08-782 28 85).

Cited literature, if any, will be enclosed in paper form.

INTERNATIONAL SEARCH REPORT
Information on patent family members

International application No.
PCT/SE2008/051488

US	20040069303	A1	15/04/2004	NONE		
US	20030192539	A1	16/10/2003	NONE		
AU	651910	B	16/03/1993	AU	2421192 A	16/03/1993
				CA	2093809 A	16/02/1993
				EP	0553326 A	04/08/1993
				FI	931661 A	14/04/1993
				HU	64242 A	28/12/1993
				JP	6504223 T	19/05/1994
				WO	9303782 A	04/03/1993
US	20030015195	A1	23/01/2003	NONE		
US	5469843	A	28/11/1995	NONE		
US	20040107963	A1	10/06/2004	NONE		
DE	102005046645	B3	20/07/2006	EP	1769818 A	20/06/2007
US	5383850	A	24/01/1995	AT	142515 T	15/09/1996
				DK	572969 T	24/02/1997
				EP	0572969 A,B	11/09/1996
				SE	0572969 T3	
				ES	2092727 T	01/12/1996
				FI	110064 B	29/11/2002
				FI	932544 A	06/12/1993
				GR	3021212 T	31/12/1996
				JP	3510647 B	29/03/2004
				JP	6039038 A	15/02/1994
				NO	304876 B	01/03/1999
				NO	932050 A	06/12/1993