



(51) International Patent Classification:
E04H 17/24 (2006.01)

(21) International Application Number:
PCT/GB2019/053677

(22) International Filing Date:
20 December 2019 (20.12.2019)

(25) Filing Language: English

(26) Publication Language: English

(30) Priority Data:
1820790.2 20 December 2018 (20.12.2018) GB

(71) Applicant: PROTECTAPET LIMITED [GB/GB]; St Mary's House, Crewe Road, Alsager, Stoke-on-Trent Staffordshire ST7 2EW (GB).

(72) Inventor: DAVIES, Simon Keith; St Mary's House, Crewe Road, Alsager, Stoke-on-Trent Staffordshire ST7 2EW (GB).

(74) Agent: SWINDELL & PEARSON LIMITED; 48 Friar Gate, Derby Derbyshire DE1 1GY (GB).

(81) Designated States (unless otherwise indicated, for every kind of national protection available): AE, AG, AL, AM, AO, AT, AU, AZ, BA, BB, BG, BH, BN, BR, BW, BY, BZ, CA, CH, CL, CN, CO, CR, CU, CZ, DE, DJ, DK, DM, DO, DZ, EC, EE, EG, ES, FI, GB, GD, GE, GH, GM, GT, HN, HR, HU, ID, IL, IN, IR, IS, JO, JP, KE, KG, KH, KN, KP, KR, KW, KZ, LA, LC, LK, LR, LS, LU, LY, MA, MD, ME, MG, MK, MN, MW, MX, MY, MZ, NA, NG, NI, NO, NZ, OM, PA, PE, PG, PH, PL, PT, QA, RO, RS, RU, RW, SA, SC, SD, SE, SG, SK, SL, SM, ST, SV, SY, TH, TJ, TM, TN, TR, TT, TZ, UA, UG, US, UZ, VC, VN, ZA, ZM, ZW.

(84) Designated States (unless otherwise indicated, for every kind of regional protection available): ARIPO (BW, GH, GM, KE, LR, LS, MW, MZ, NA, RW, SD, SL, ST, SZ, TZ, UG, ZM, ZW), Eurasian (AM, AZ, BY, KG, KZ, RU, TJ, TM), European (AL, AT, BE, BG, CH, CY, CZ, DE, DK, EE, ES, FI, FR, GB, GR, HR, HU, IE, IS, IT, LT, LU, LV, MC, MK, MT, NL, NO, PL, PT, RO, RS, SE, SI, SK, SM, TR), OAPI (BF, BJ, CF, CG, CI, CM, GA, GN, GQ, GW, KM, ML, MR, NE, SN, TD, TG).

(54) Title: BARRIER ASSEMBLY

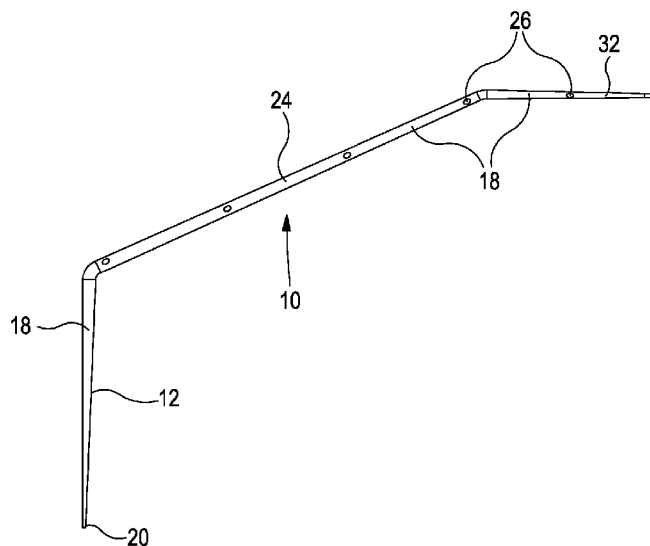

FIG. 1

(57) Abstract: A barrier assembly including a bracket member (10) with a base (14) and an inclined upper part (16). An alignment adaptor (36) may be provided which mounts the bracket (10) at an inclination to a mounting surface for instance for use in corners. The bracket member 10 may be mounted on an extension member (68) which enables the bracket member to extend higher than would otherwise be the case.



WO 2020/128524 A2

Published:

- *without international search report and to be republished upon receipt of that report (Rule 48.2(g))*

Barrier Assembly

This invention concerns improvements in or relating to barrier assemblies, and also kits of parts for forming barrier assemblies.

5

Overhanging bracket assemblies are often required at the top of a closure such as a fence or wall to prevent animals or people climbing over the closure. Conventionally inclined brackets are used, which brackets include a first part engageable against the closure, and an inclined part extending therefrom which will generally extend upwardly and inwardly. A further top part at a greater inclination to the closure may extend at least generally perpendicularly to the closure.

10

Conventionally mesh, netting, wires or other barrier materials may be provided extending between the brackets. Existing arrangements often require a number of different brackets usable in different situations. For instance inclined brackets may be required for use in corners where the bracket inclined part will usually be required to extend at an inclination in a required direction of around 45° to the first part. Also longer brackets may be needed for instance for lower height closures.

20

According to a first aspect of the invention there is provided a barrier assembly, the assembly comprising a bracket member which comprises a first mounting part and a second barrier part extending in use at a vertical inclination relative thereto, the assembly also including an alignment adaptor mountable to a surface of a closure member, with the bracket member mountable to the alignment adaptor, such that the mounting part is inclined relative to the closure member surface, about a vertical axis.

25

The alignment adaptor may include a first formation mountable to the surface of a closure member, and a second formation to which a bracket member is mountable.

30

The first formation may include a plurality of through holes through which a fastening means can extend. The second formation may include an engagement face against which a barrier member can engage, which
5 engagement face will be inclined relative to the surface of a closure member to which the alignment adaptor is mounted.

The engagement face may extend at substantially 45° to the surface of a closure member to which the alignment adaptor is mounted.

10

The engagement face may be configured such that it can be inclined in either direction relative to the surface of a closure, and may be movable between inclinations in either direction by rotating through 180°.

15 The second formation may include a plurality of holes, which may be threaded.

In one arrangement the alignment adaptor is in the form of a hollow body which is at least generally triangular in plan view. The hollow body may be
20 made of a plastics material.

In a further arrangement the alignment adaptor may have a generally L shaped configuration. The connection between the limbs of the L may be inclined, and the second formation may be provided in the inclined connection.

25

According to a second aspect of the invention there is provided a bracket member comprising a first mounting part, and a second barrier part extending at a vertical inclination relative thereto, the assembly also including an extension member, which extension member is mountable on a closure
30 member, with a bracket member mountable to the extension member so as to extend higher than if the bracket member was mounted directly to the closure member.

Third mounting formations may be provided on the extension member to enable mounting of the extension member to a closure, and the third mounting formations may comprise a plurality of spaced holes.

5

A base formation may be provided on the extension member to receive the lower end of a bracket member mounted thereto.

10 The extension member may have a base part locatable against a closure member, with side walls extending from the base part such that a bracket member can slidingly locate between the side walls. The side walls may taper outwardly in an upwards direction. Inward projections may be provided on the side walls to retain a bracket member therebetween.

15 According to a third aspect of the invention there is provided a bracket member comprising a first mounting part, and a second barrier part extending in use at a vertical inclination relative thereto, the bracket member having a generally channel section profile with a base and side walls.

20 The side walls may taper outwardly on the mounting part towards the barrier part. The side walls may taper inwardly on the barrier part away from the mounting part.

25 The bracket member may also include a third part extending from the barrier part at a greater inclination to the mounting part. The side walls of the third part may taper inwardly away from the barrier.

A plurality of adjacent through holes may be provided in the base and side walls of the barrier part, to permit mounting of items to the bracket member.
30 Adjacent through holes may also be provided in the third part of the barrier member.

The base of the bracket member channel section may be profiled and may have a raised central section which may extend for the majority of the width of the channel section.

5 The side walls of the channel section may be inclined outwardly.

The bracket members may be made of metal and for instance steel, and may be made by stamping or pressing.

10 The extension members may be made of metal and for instance steel, and may be made by stamping or pressing.

According to a still further aspect of the invention there is provided a first kit of parts for forming a barrier assembly, the kit of parts including a plurality of
15 bracket members and alignment adaptors according to any of the preceding paragraphs.

According to a yet further aspect of the invention there is provided a second kit of parts for forming a barrier assembly, the kit of parts including a
20 plurality of bracket members and extension members according to any of the preceding paragraphs.

The second kit of parts may also include a plurality of alignment
25 adaptors.

The invention further provides a barrier assembly including a plurality of bracket members according to any of the preceding paragraphs, with barrier means extending between the bracket members.

30 The barrier assembly may also include one or more extension members.

The barrier assembly may also include one or more alignment adaptors.

Embodiments of the present invention will now be described by way of example only and with reference to the accompanying drawings, in which:-

5 Fig. 1 is a diagrammatic side view of a bracket member according to the invention;

Fig. 2 is a front view of the bracket member of Fig. 1;

10 Fig. 3 is a diagrammatic perspective view of the bracket member of Fig. 1;

Fig. 4 is a diagrammatic cross sectional plan view of part of the bracket member of Fig. 1;

15

Fig. 5 is a diagrammatic sectional view of part of the bracket member of Fig. 1;

20 Fig. 6 is a diagrammatic perspective view of the bracket member of Fig. 1;

Fig. 7 is a more detailed diagrammatic perspective view of part of the assembly of Fig. 1.

25 Fig. 8 is a front view of a first alignment adaptor according to the invention;

Fig. 9 is a diagrammatic rear view of the adaptor of Fig. 8;

30 Fig. 10 is a diagrammatic perspective view of the adaptor of Fig. 8;

Fig. 11 is a diagrammatic plan view of the adaptor of Fig. 8;

Fig. 12 is a more detailed diagrammatic perspective view of an upper part of the adaptor of Fig. 8;

5 Fig. 13 is a diagrammatic front view of a second alignment adaptor according to the invention;

Fig. 14 is a diagrammatic plan view of the adaptor of Fig. 13;

10 Fig. 15 is a diagrammatic perspective view from above of the adaptor of Fig. 15;

Fig. 16 is a diagrammatic front view of an extension member according to the invention;

15

Fig. 17 is a diagrammatic side view of the extension member of Fig. 16;

Fig. 18 is a diagrammatic perspective view of the extension of Fig. 16;

20 Fig. 19 is a diagrammatic side view showing the use of a barrier assembly according to the invention;

Fig. 20 is a diagrammatic perspective view from above of a first arrangement of a barrier assembly according to the invention;

25

Fig. 21 is a plan view of a further configuration of a barrier assembly according to the invention;

30 Fig. 22 is a diagrammatic perspective view from above of the arrangement of Fig. 21 but with some components removed;

Fig. 23 is a diagrammatic perspective view of part of the arrangement of Fig. 21;

5 Fig. 24 is a diagrammatic plan view of the part of the assembly shown in Fig. 23;

Fig. 25 is a diagrammatic perspective view of a further barrier assembly according to the invention;

10 Fig. 26 is a more detailed view of part of the assembly of Fig. 25;

Fig. 27 is a diagrammatic perspective view of part of a still further barrier assembly according to the invention; and

15 Fig. 28 is a more detailed view of part of the assembly of Fig. 27.

The drawings show various barrier assemblies and components used therein to provide an overhanging barrier arrangement. The assembly in particular comprises one or more of bracket members (Fig. 1), an alignment
20 adaptor (Fig. 8) and/or an extension member (Fig. 16).

Fig. 1 shows a bracket 10 member comprises a first mounting part 12 formed of a generally channel cross section as shown in Fig. 4, with a base 14 with an upper raised part 16 and side walls 18 which diverge gently outwardly.
25 The side walls 18 increase in height away from their lower end 20 in use. A plurality of spaced mounting holes 22 are provided in the base 14 of the mounting part 12. The mounting part 12 connects to a barrier part 24 which is inclined relative to the mounting part to provide an overhang in use. The side walls 18 reduce gently in height in the barrier part 24 away from the mounting
30 part 12.

A plurality of spaced pairs 26 of adjacent fixing holes 28 are provided respectively in the base 14 of the channel of the barrier part, and adjacent in respective side wall 18 for mounting a cable tie 30 as shown for example in Fig. 7, to mount an item or material to the bracket member 10. As can be seen from
5 Fig. 6 the pairs 26 of fixing holes are provided alternately on opposite sides of the barrier part 24.

A further top part 32 extends from the free end of the barrier part 24 and again the height of the side walls 18 decreases gently along the top part 32,
10 and a pair 26 of adjacent fixing holes are provided on each side, with a final mounting hole 34 at the end of the top part 32.

The bracket members 10 may be formed by stamping or pressing of galvanised steel. The formation of the base 14 of the channel has been found
15 to provide significant additional strength relative to a non profiled channel, which therefore permits thinner material to be used whilst obtaining equal or enhanced performance. This therefore provides a weight and cost reduction.

Figs. 8 to 11 show a first alignment adaptor 36 which is in the form of a
20 profiled open body of a glass filled plastics material made for instance by injection moulding. The alignment adaptor 36 provides an open surface 38 engageable against a fence post 40 or the like. The adaptor 36 also provides a flat engagement face 42 inclined at substantially 45° to the open surface 38. A gently curved face 44 extends between the open surface 38 and engagement
25 face 42. A pair of mounting holes 46 are provided in the junction between the engagement face 42 and curved face 44, to permit mounting of the adaptor 36 to a fence post 40 or similar. A further pair of holes 48 are provided in the engagement face 42, which holes 48 are threaded to permit a bracket member
30 10 to be mounted to the alignment adaptor 36, by screws engaging in the holes 48.

Figs. 23 and 24 show a corner adaptor mounted 36 on a face 50 of a square fence post 40, thereby meaning that the bracket member 10 extends at 45° relative to the two perpendicular sides 54 of a fence which meet at the fence post 40.

5

Figs. 13 to 15 show a second alignment adaptor 56. In this instance the alignment adaptor 56 has a generally L shape cross section in plan view, except that there is an inclined web 58 between the two limbs 60 of the L shape, defining the apex of the L. Three mounting holes 62 are provided in the web 58 to permit mounting of the adaptor 56 to a fence post 40 or the like. A pair of mounting holes 64 are provided on a one of the limbs 60 of the L with a threaded boss 66 to permit a bracket member 10 to be mounted thereto. The second alignment adaptor 56 is formed for instance of folded steel.

10

15

Figs. 16 to 18 show an extension member 68 which enables a bracket member 10 to extend higher than would otherwise be the case. The extension member 68 is formed of plain channel section with the height of the side walls 70 increasing upwardly in use. A plurality of mounting holes 72 are provided in the base of the channel of the extension member 68, to permit mounting thereof to a fence post 40 or the like, or an alignment adaptor 36, 56. Spaced upwardly from the lower end of the extension member 68 is an outwardly extending flap 74 to supportingly receive the lower end of a bracket member 10 mounted thereto. A pair of folded tabs 76 are provided extending inwardly from the side walls 70 of the channel at an upper end of the extension member 68. An extension member 68 can again be provided by stamping or pressing galvanised steel.

20

25

A bracket member 10 can be mounted to the extension member 68 by sliding the lower end of the mounting part 12 so as to engage against the flap 74, with the tabs 76 retaining the bracket member 10 in a sliding fit relative to the channel of the extension member 68. Screws can then pass through a hole 22 in the base 14 of the bracket member 10 and the extension member 68, to

30

engage in a fence post 40 for example as shown in Figs. 25 and 26, or an alignment adaptor 36 as shown for instance in Figs. 27 and 28.

Therefore a barrier assembly is provided which can be formed from a
5 number of bracket members, alignment adaptors and/or extension members.
This permits the same bracket members to be usable in a straight section of
fencing such as shown for instance in Fig. 20, or in corners as shown for
instance in Figs. 21 to 24. The extension members enable the same bracket
members to be used for instance with lower fences or walls. Therefore a kit of
10 parts can be provided with only two or three different components but which
can be used in combination as required.

A range of modifications may be made without departing from the scope
of the invention. For instance the bracket members may take a different form.
15 As indicated the alignment adaptors can take different forms, and it is to be
realised that both forms described can simply be turned through 180° for use in
an opposite handed corner. The extension members may take a different form,
and could for instance be of a different size if required.

20 Whilst endeavouring in the foregoing specification to draw attention to
those features of the invention believed to be of particular importance it should
be understood that the Applicant claims protection in respect of any patentable
feature or combination of features hereinbefore referred to and/or shown in the
drawings whether or not particular emphasis has been placed thereon.

25

CLAIMS

- 1 A barrier assembly, the assembly comprising a bracket member which
comprises a first mounting part and a second barrier part extending in use at a
5 vertical inclination relative thereto, the assembly also including an alignment
adaptor mountable to a surface of a closure member, with the bracket member
mountable to the alignment adaptor, such that the mounting part is inclined
relative to the closure member surface, about a vertical axis.
- 10 2. A barrier assembly according to claim 1, in which the alignment adaptor
includes a first formation mountable to the surface of a closure member, and a
second formation to which a bracket member is mountable.
- 15 3. A barrier assembly according to claim 2, in which the first formation
includes a plurality of through holes through which a fastening means can
extend.
4. A barrier assembly according to claims 2 or 3, in which the second
formation includes an engagement face against which a barrier member can
20 engage, which engagement face will be inclined relative to the surface of a
closure member to which the alignment adaptor is mounted.
5. A barrier assembly according to claim 4, in which the engagement face
extends at substantially 45° to the surface of a closure member to which the
25 alignment adaptor is mounted.
6. A barrier assembly according to claims 4 or 5, in which the engagement
face is configured such that it can be inclined in either direction relative to the
surface of a closure.
- 30 7. A barrier assembly according to any of claims 4 to 6, in which the second
formation includes a plurality of holes.

8. A barrier assembly according to any of the preceding claims, in which the alignment adaptor is in the form of a hollow body which is at least generally triangular in plan view.

5

9. A barrier assembly according to any of claims 1 to 7, in which the alignment adaptor has a generally L shaped configuration, with the connection between the limbs of the L inclined, and the second formation provided in the inclined connection.

10

10. A bracket member comprising a first mounting part, and a second barrier part extending at a vertical inclination relative thereto, the assembly also including an extension member, which extension member is mountable on a closure member, with a bracket member mountable to the extension member so as to extend higher than if the bracket member was mounted directly to the closure member.

15

11. A bracket member according to claim 10, in which third mounting formations are provided on the extension member to enable mounting of the extension member to a closure.

20

12. A bracket member according to claims 10 or 11, in which a base formation is provided on the extension member to receive the lower end of a bracket member mounted thereto.

25

13. A bracket member according to any of claims 10 to 12, in which the extension member has a base part locatable against a closure member, with side walls extending from the base part such that a bracket member can slidably locate between the side walls, the extension member side walls taper outwardly in an upwards direction, and inward projections are provided on the extension member side walls to retain a bracket member therebetween.

30

14. A bracket member comprising a first mounting part, and a second barrier part extending in use at a vertical inclination relative thereto, the bracket member having a generally channel section profile with a base and side walls.

5 15. A bracket member according to claim 14, in which the bracket member also includes a third part extending from the barrier part at a greater inclination to the mounting part.

10 16. A bracket member according to claims 14 or 15, in which a plurality of adjacent through holes are provided in the base and side walls of the barrier part, to permit mounting of items to the bracket member.

15 17. A bracket member according to any of claims 14 to 16, in which the base of the bracket member channel section is profiled and has a raised central section.

18. A bracket member according to claim 17, in which the raised central section extends for the majority of the width of the channel section.

20 19. A bracket member according to any of claims 14 to 18, in which the side walls of the channel section are inclined outwardly.

25 20. A first kit of parts for forming a barrier assembly, the kit of parts including a plurality of bracket members and alignment adaptors according to any of the preceding claims.

21. A second kit of parts for forming a barrier assembly, the kit of parts including a plurality of bracket members and extension members according to any of the preceding claims.

22. A second kit of parts according to claim 21, in which the second kit of parts also includes a plurality of alignment adaptors according to any of the preceding claims.

5 23. A barrier assembly including a plurality of bracket members according to any of the preceding claims, with barrier means extending between the bracket members.

10 24. A barrier assembly according to claim 24, in which the barrier assembly also includes one or more extension members according to any of the preceding claims.

15 25. A barrier assembly according to claims 23 or 24, in which the barrier assembly also includes one or more alignment adaptors according to any of the preceding claims.

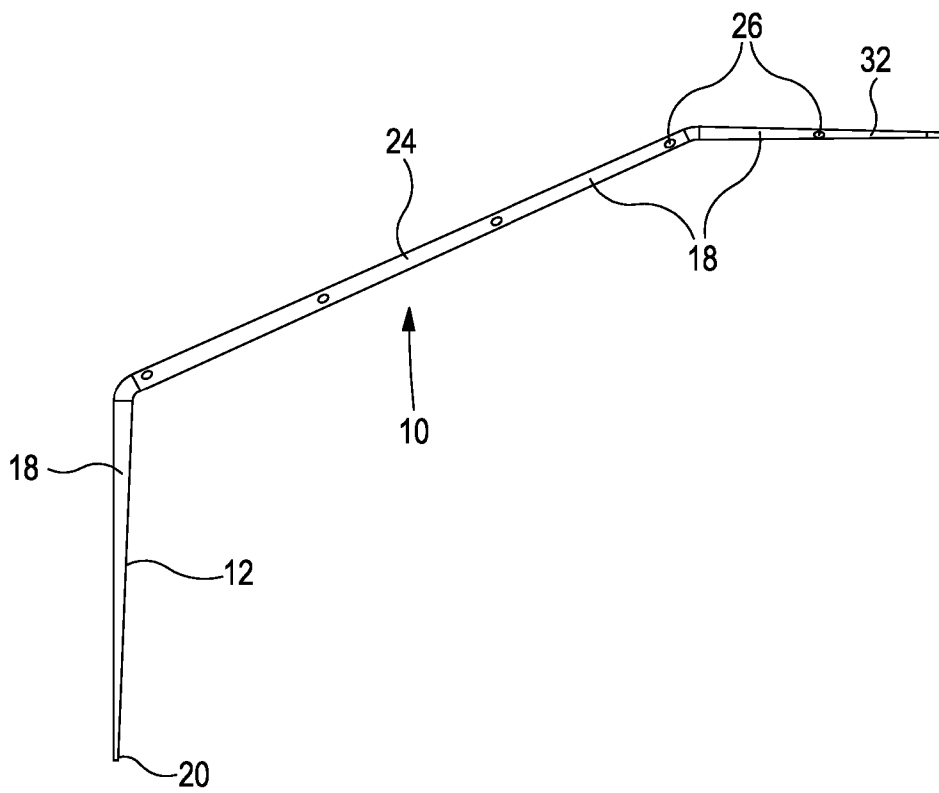

FIG. 1

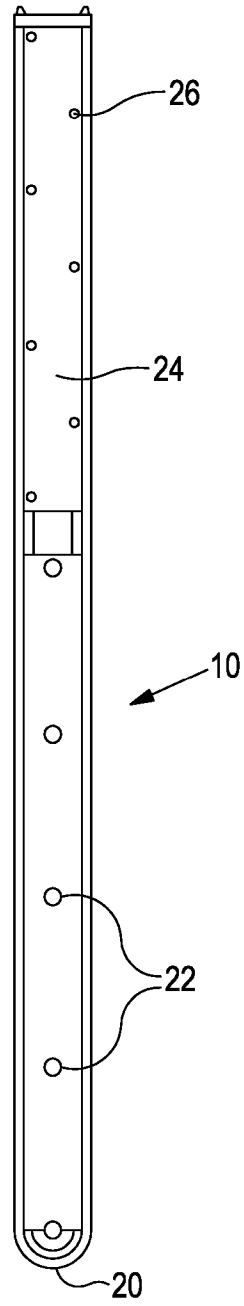

FIG. 2

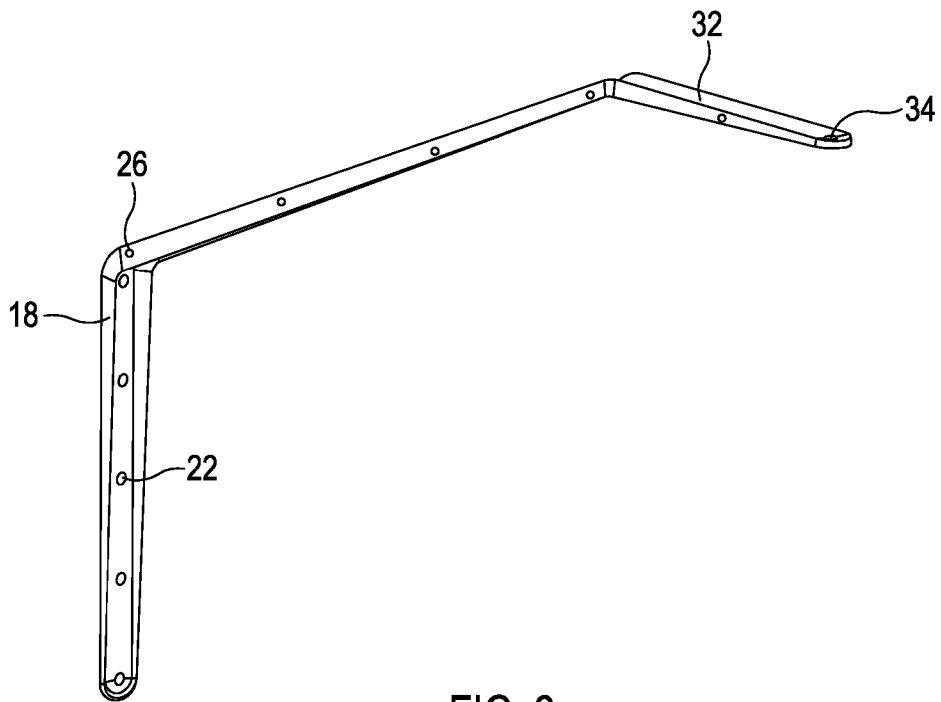

FIG. 3

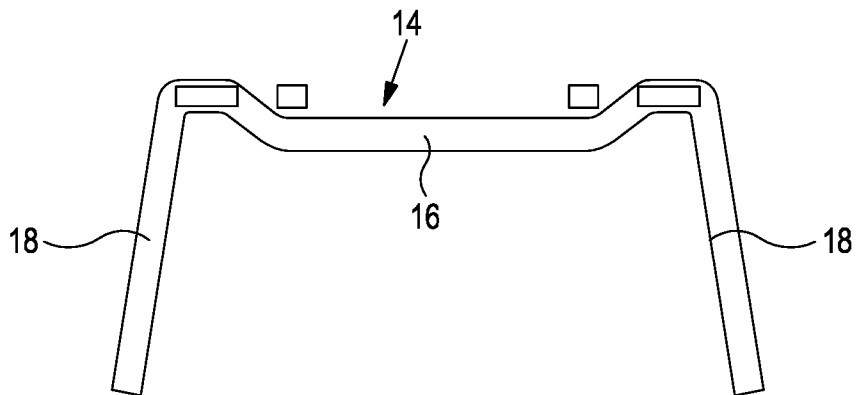

FIG. 4

4/17

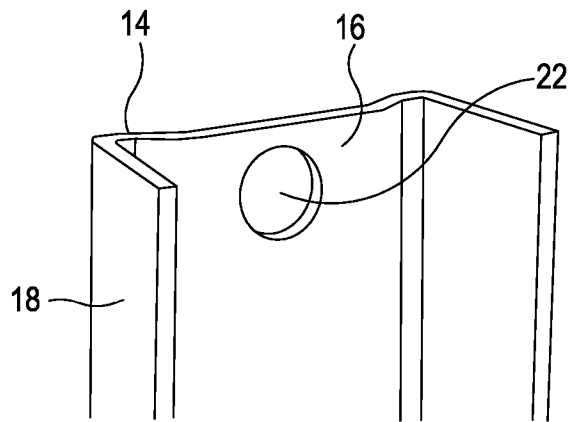

FIG. 5

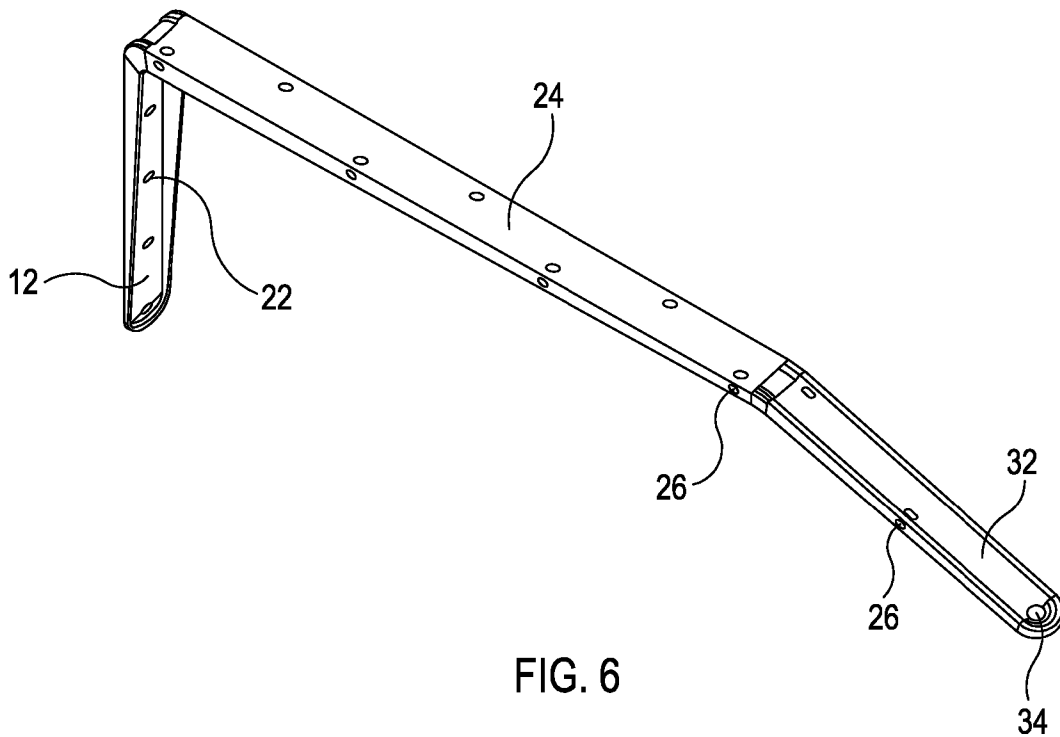
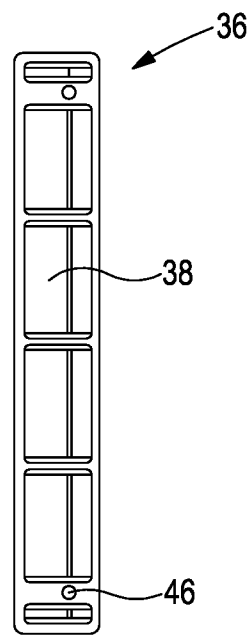
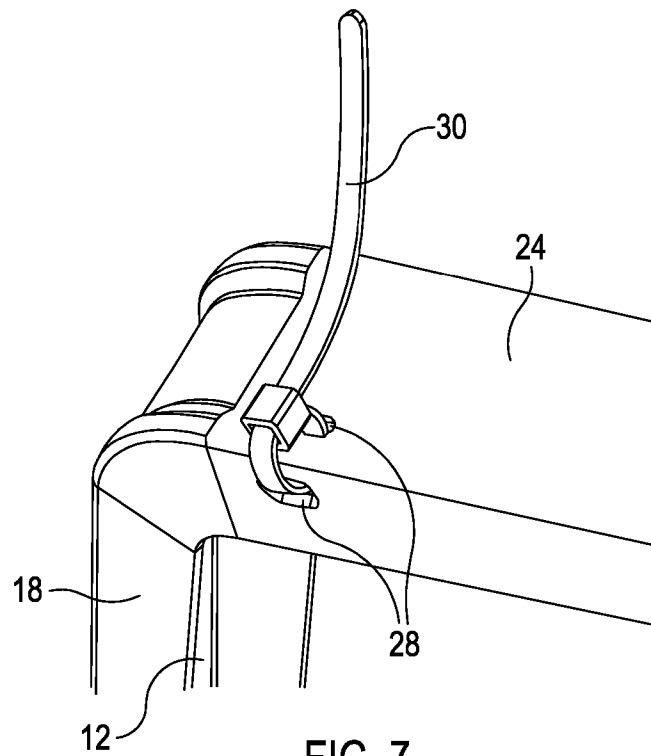

FIG. 6



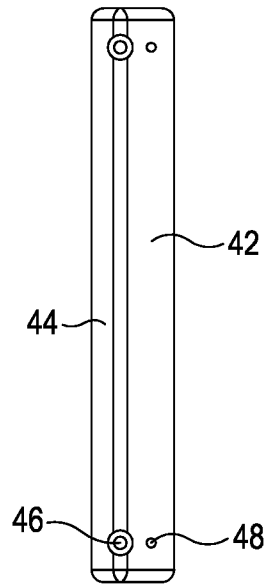

FIG. 9

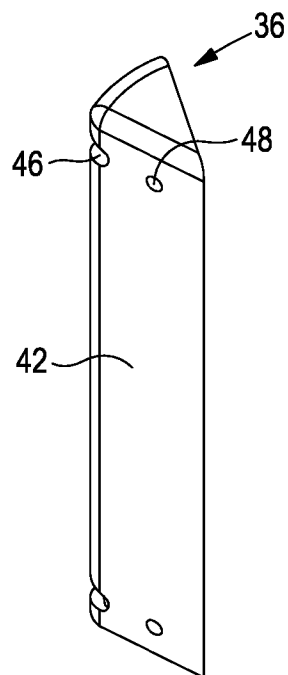

FIG. 10

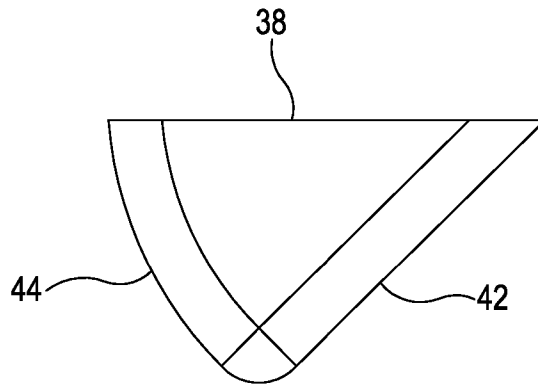

FIG. 11

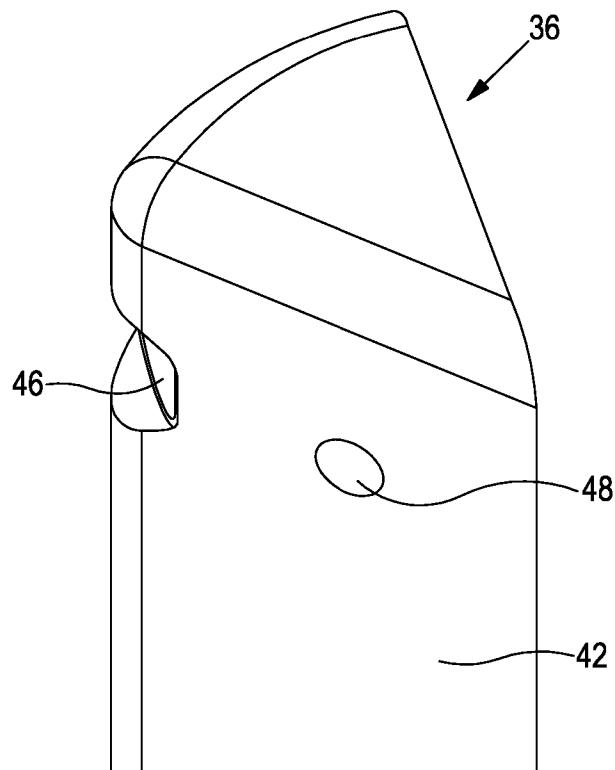

FIG. 12

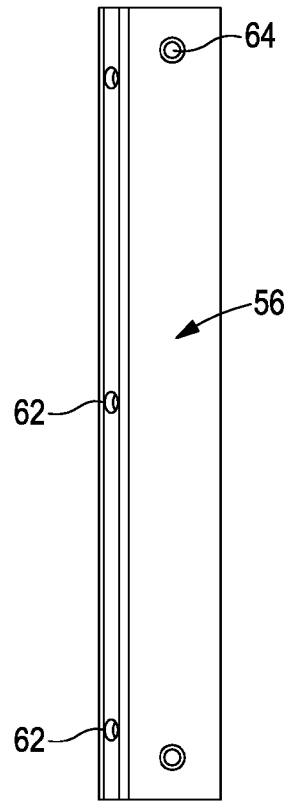

FIG. 13

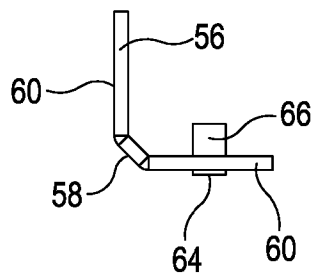

FIG. 14

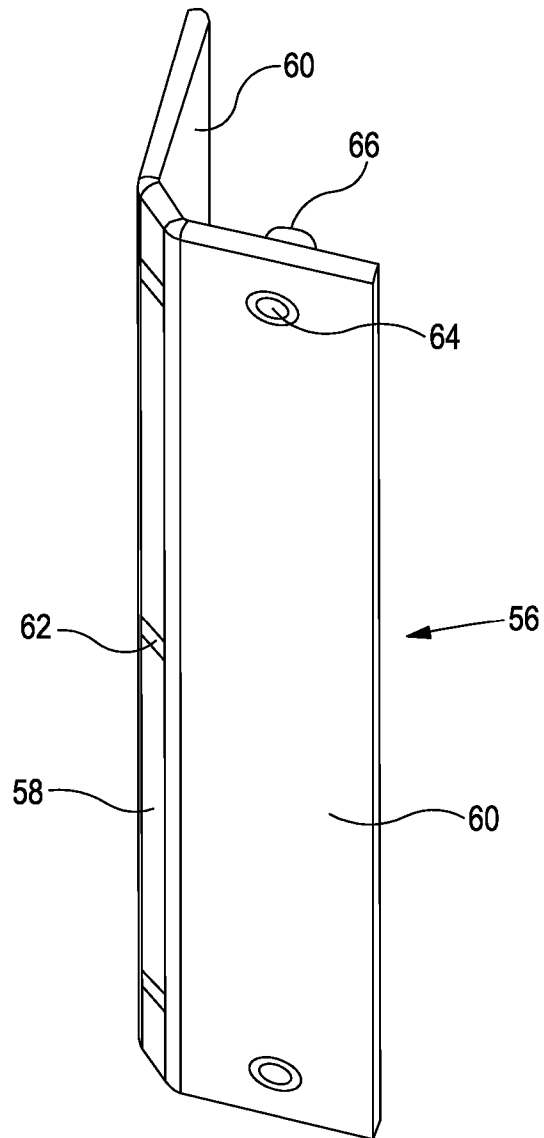

FIG. 15

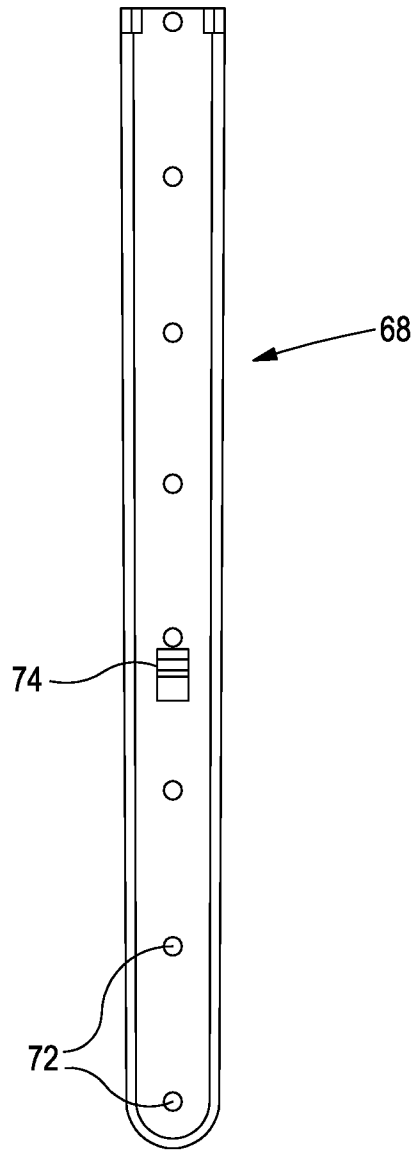

FIG. 16

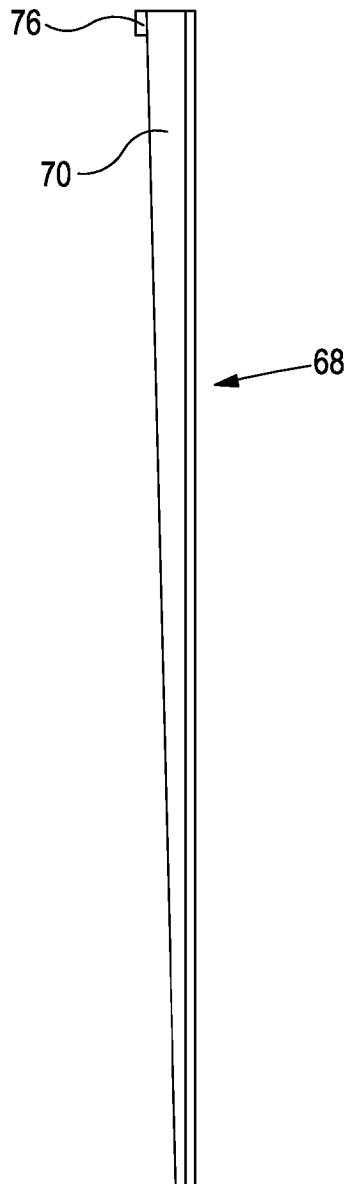

FIG. 17

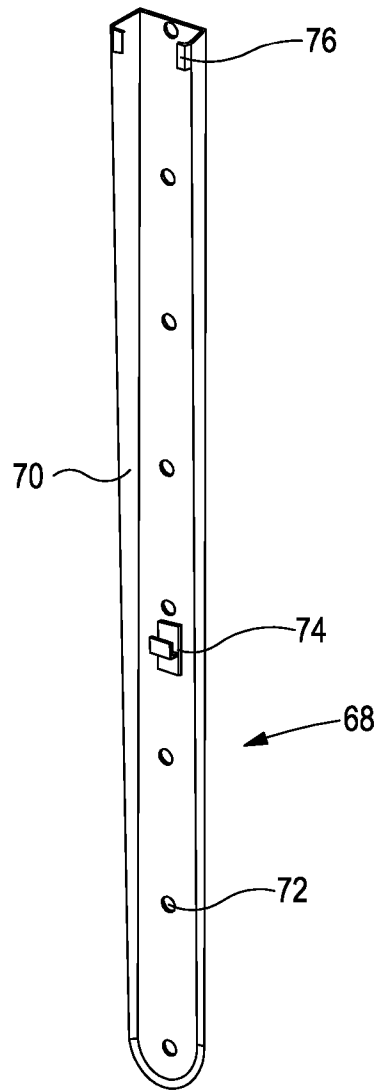

FIG. 18

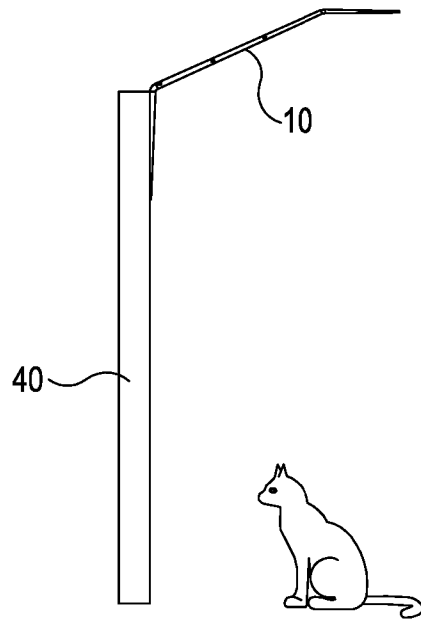

FIG. 19

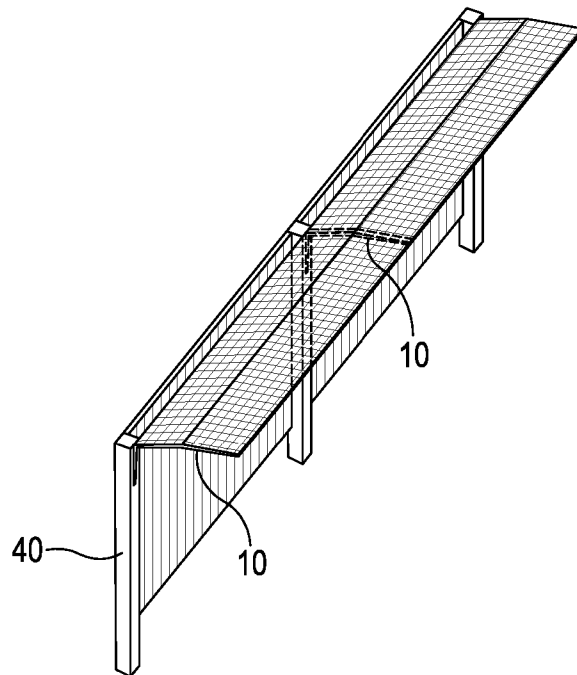

FIG. 20

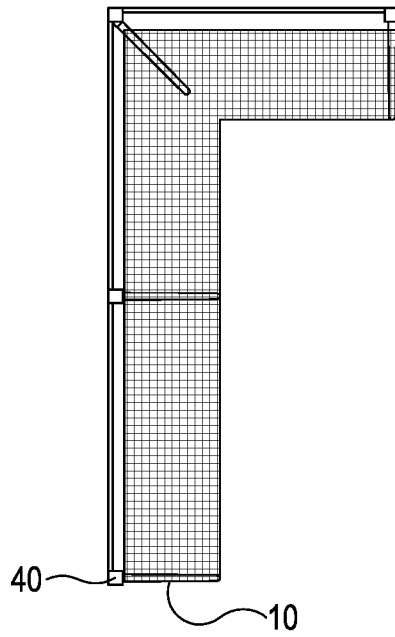

FIG. 21

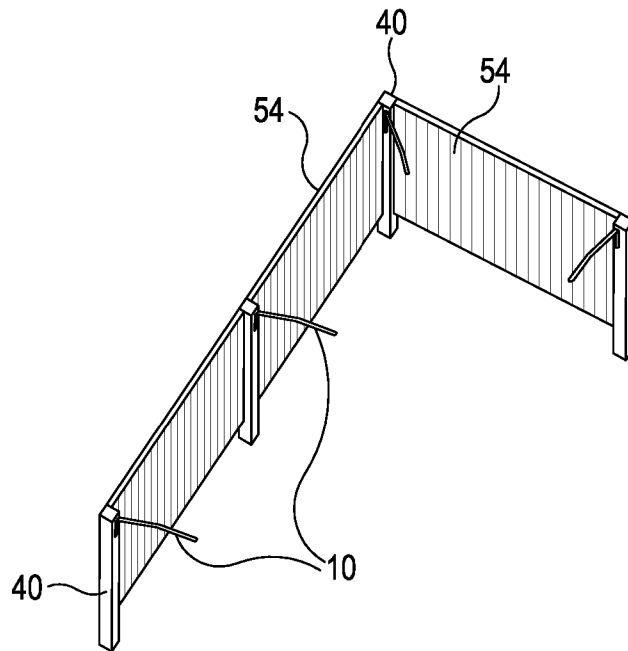

FIG. 22

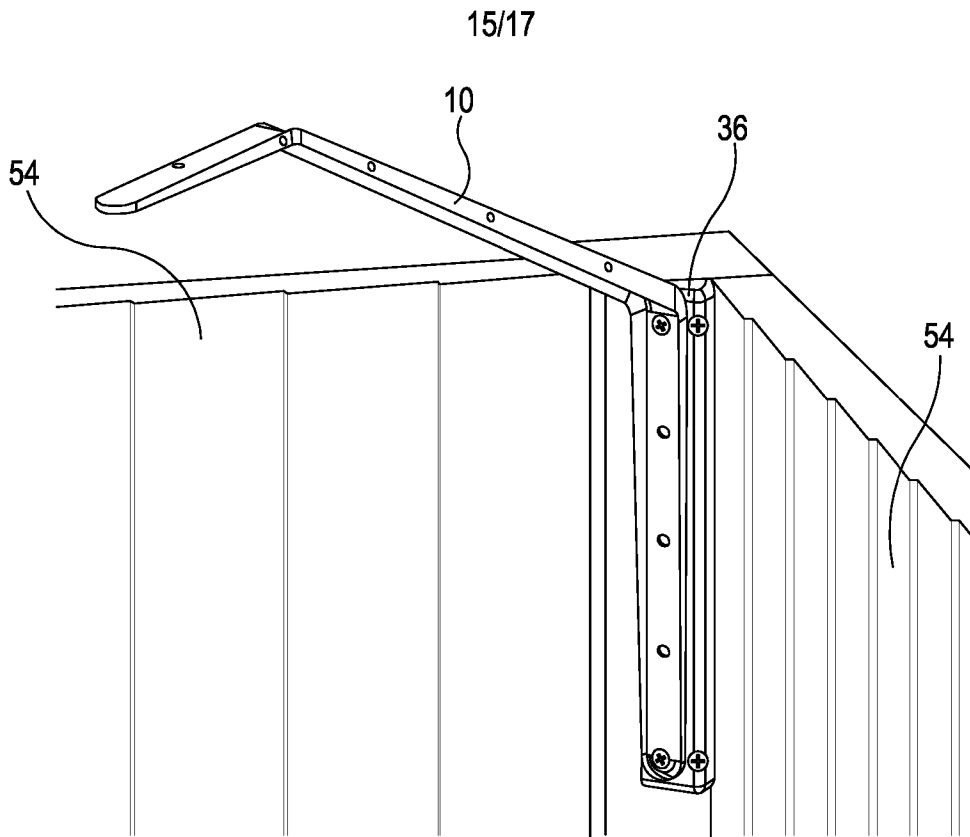

FIG. 23

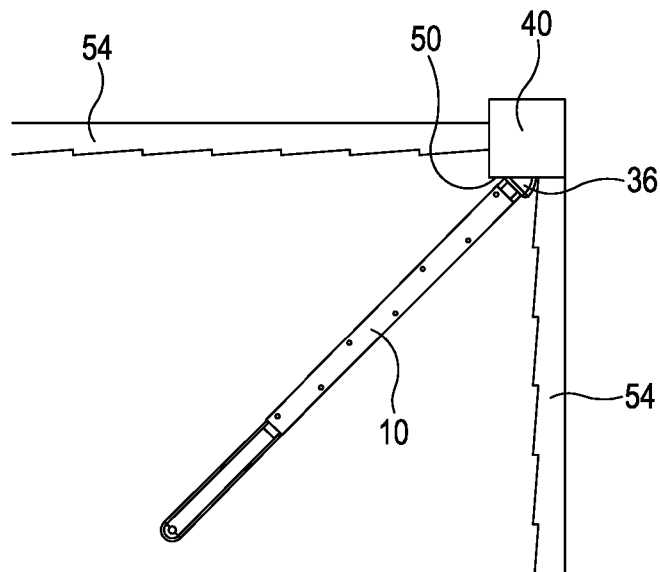

FIG. 24

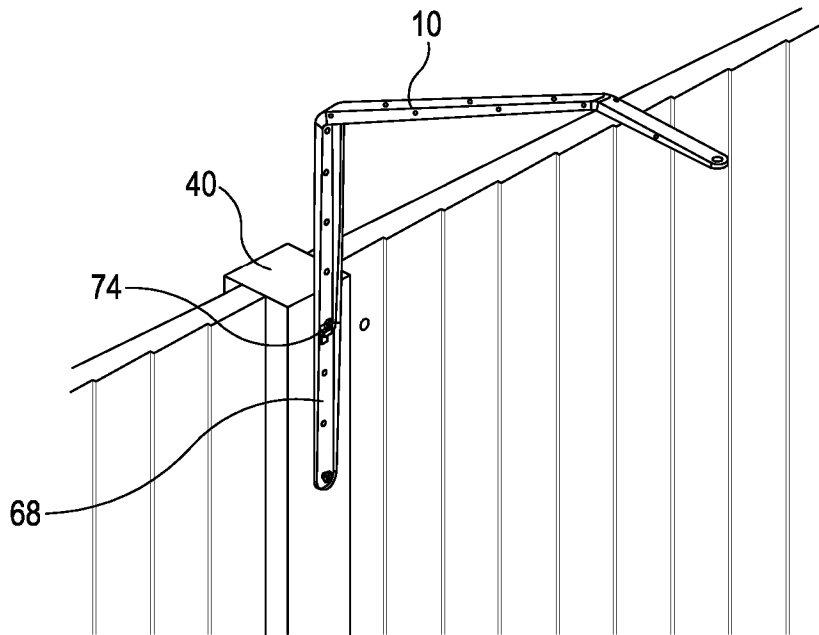

FIG. 25

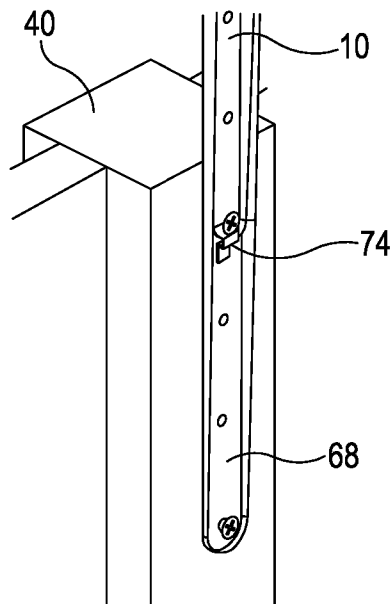

FIG. 26

17/17

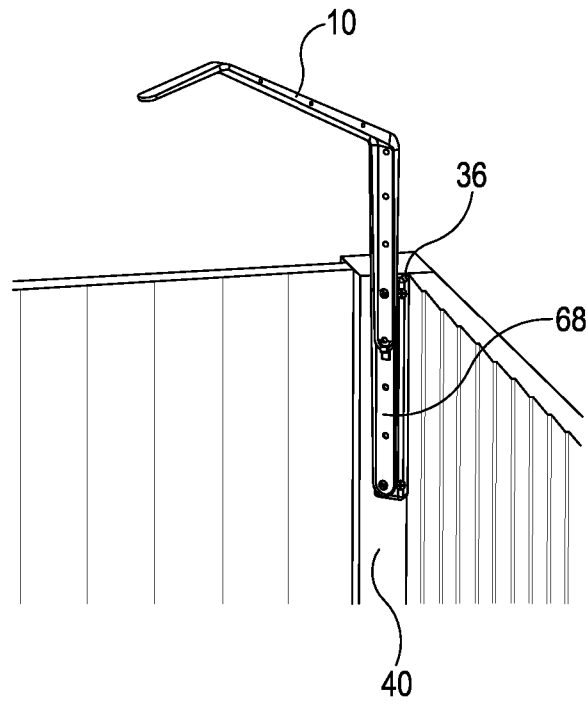

FIG. 27

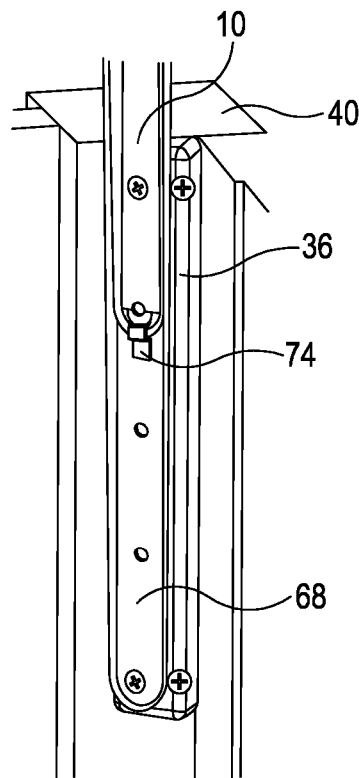

FIG. 28