

(19)



(11)

EP 2 055 860 A1

(12)

EUROPEAN PATENT APPLICATION

(43) Date of publication:
06.05.2009 Bulletin 2009/19

(51) Int Cl.:
E04D 13/03 (2006.01)

(21) Application number: **07388078.3**

(22) Date of filing: **02.11.2007**

(84) Designated Contracting States:
**AT BE BG CH CY CZ DE DK EE ES FI FR GB GR
 HU IE IS IT LI LT LU LV MC MT NL PL PT RO SE
 SI SK TR**
 Designated Extension States:
AL BA HR MK RS

(72) Inventors:
 • **Mogensen, Morten Moller
 8361 Hasselager (DK)**
 • **Jorgensen, Lars Folling
 8660 Skanderborg (DK)**

(71) Applicant: **VKR Holding A/S
 2970 Hørsholm (DK)**

(74) Representative: **Rohde, Vibeke Warberg et al
 Internationalt Patent-Bureau A/S
 Rigensgade 11
 1316 Copenhagen K (DK)**

(54) **A method and covering kit for sound dampening a roof window**

(57) A method and a covering kit for improving the sound dampening properties of a roof window is provided. The sound dampening is achieved by applying an adhesive tape to at least one member of a covering kit, which comprises a number of flashing, cladding and covering members and which is used for covering the exterior surfaces of the frame(s) and the joints between the roof surface and outer frame surfaces and between exterior

frame surfaces and the pane. The adhesive tape can be applied to all sections of the covering kit members, which are substantially parallel to the pane in the mounted state and which are not covered by roofing material. Preferably to interior surfaces of the covering kit member(s). If the covering kit member(s) is made by deformation of a sheet material, the adhesive tape can be applied prior to deformation. Preferably over the entire length of the covering kit member(s).

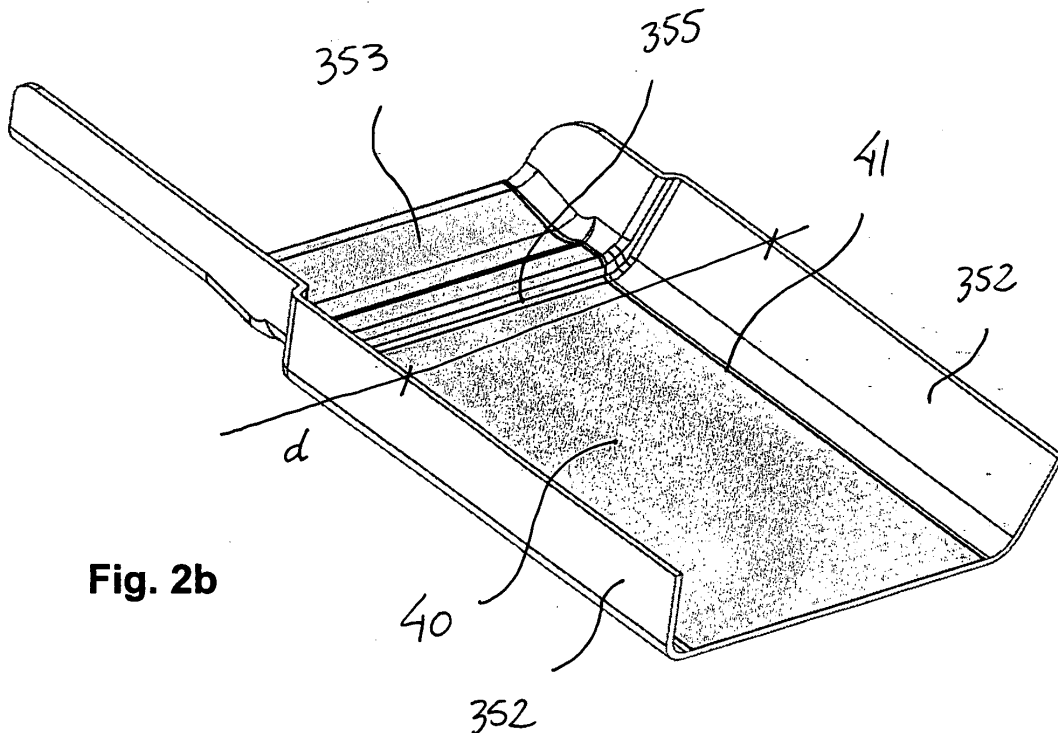

Fig. 2b

EP 2 055 860 A1

Description

[0001] The present invention relates to a method for improving the sound dampening properties of a roof window, which, in the mounted state, penetrates a roof surface, said roof window comprising a pane and at least one frame surrounding the pane. The invention further relates to a covering kit and to a sound dampened roof window.

[0002] Over the years, there have been countless attempts to adapt the design of the window pane as well as spacer members and gaskets used therewith to achieve a better sound dampening. Many of these have proven very successful and are widely used.

[0003] The main focus has been on the dampening of external sound such as traffic noise etc., but the noise caused by precipitation striking the window has also been considered and this factor has been taken into account in the design of most modern panes.

[0004] As glass is still the preferred material for the pane there is a limit to the possible reduction of the noise. In DE19635463 it was therefore proposed to cover the window with a rubber roller blind whenever the noise caused by precipitation becomes too loud. This method, however, requires either a manual activation or the incorporation of a motor and a sound or precipitation sensor. The manual activation will be considered a considerable disadvantage, when the precipitation occurs at night-time. The incorporation of sensors on the other hand causes the price of the window to become considerably higher and necessitates more frequent and more complex maintenance operations.

[0005] It is therefore the object of the invention to provide a method of improving the sound dampening properties of roof windows as regards the noise caused by precipitation without the need for manual activation, without increasing the price and without necessitating an increase in maintenance.

[0006] According to the invention this has been achieved by applying an adhesive tape to at least one member of the covering kit, which comprises a number of flashing, cladding and covering members and which is used for covering the exterior surfaces of the frame(s) and the joints between the roof surface and outer frame surfaces and between exterior frame surfaces and the pane.

[0007] As opposed to what has previously been thought, the dampening of the noise caused by the precipitation striking the covering kit members does in fact cause an audible decrease in the sound level on the interior side of the window. Tests have shown decreases of up to 7 dB in comparison with a window fitted with a standard covering kit.

[0008] The adhesive tape works by dampening the vibrations in the covering kit member caused by the precipitation hitting it. The elastic adhesive both cushions the sound and functions as resilient suspension for the tape, which serves as a barrier for the sound.

[0009] It has also been considered to use a layer of foam material instead of the adhesive tape. This solution, however, has a number of disadvantages. For one, the foam layer needs to be relatively thick and the covering kit members would have to be redesigned to make room for it. For another, the application of the foam is associated with a number of disadvantage such as smudging of the exterior surfaces and pollution of the working environment. All of these disadvantages are avoided by the use of adhesive tape, wherefore this has been chosen.

[0010] A realistic alternative to the use of the adhesive tape is the use of a plastic material, which may temporarily be brought into a state where it has adhesive properties. This may for example be achieved by heating. When cooling off, the plastic will stick to the surface of the covering member while regaining its original physical properties. It may thus be said so function as a combined adhesive and tape.

[0011] The adhesive tape may in principle be applied to all members of the covering kit and cover them entirely on one or both sides. Some surfaces of the covering kit members will, however, be located in relatively protected locations, which precipitation will rarely reach. It may therefore be advantageous to only apply adhesive tape to those sections of the covering kit members, which are parallel to the pane in the mounted state and which are not covered by roofing material. It is, however, to be understood that the application of the adhesive tape does not only dampen the sound caused by the impact of each individual hail or rain drop, but that it also dampens the vibrations caused in the entire covering kit member. The application of adhesive tape to sections of the covering kit member not directly affected by the precipitation may thus also contribute to improving the acoustic image experienced by persons in the room on the interior side of the window.

[0012] For the sake of weatherproofing the adhesive tape is preferably applied to an interior surface of the covering kit member(s), preferably during the manufacture of the covering kit member(s). If applying the adhesive tape prior to surface treatment, such as lacquering, it may, however, also be applied on the exterior side. If wishing to improve the sound dampening properties of windows already installed, the application on the exterior side may be the only possibility.

[0013] Some covering kit members have a relatively deep trough shape, which may make it difficult to apply the adhesive tape. If these members are made by deformation of a sheet material it may therefore be advantageous to apply the adhesive tape prior to the deformation. Some kinds of adhesive tape will be capable of following even large deformations, but in other cases it may be necessary to limit the application to sections not directly affected by the deformation.

[0014] The adhesive tape used may of course be of a pre-manufactured type, but when working with covering kit members being manufactured continuously from strips of metal, by extrusion or the like it will often be

advantageous to apply the adhesive and the tape in two separate steps. This may for example be done by first applying a pressure-sensitive adhesive to the material of the covering kit member and then applying a tape of metal, plastic or the like on top thereof. A rolling mill may be used for this purpose.

[0015] As the cost of the materials used for the adhesive tape will usually be very modest it will normally be preferred to apply it substantially over the entire length of the covering kit member(s). In some cases it may, however, lead to an improved sound dampening if the adhesive tape is applied at discrete sections of the covering kit member(s). This may for example be achieved by applying adhesive tape in the form of sticker-like punched out portions, which may be rectangular or have more complex shapes.

[0016] The adhesive tape may in principle be any that gives a satisfactory sound dampening. However, as the covering kit members will be subjected to relatively large variations in temperature and humidity due to shifting weather, it will be advantageous if the adhesive tape has substantially the same coefficient of expansion as regards moisture and temperature as the material used for the covering kit member itself. This may easily be achieved by using a tape made from the same material as the covering kit member(s), i.e. usually aluminium.

[0017] The tape need not be homogeneous, but may have a grid-like structure, where thicker material sections alternate with section of thinner material or holes. Composite materials may also be used.

[0018] As for the adhesive it is preferred to use an acrylic adhesive as this have proven both reliable and durable, but other adhesives such as butyl may of course also be used.

[0019] In the following, an embodiment of the invention will be described with reference to the following drawing, in which:

Fig. 1 is a roof window mounted in an inclined roof and provided with a covering kit according to the invention,

Figs. 2a and 2b are perspective views of a side cladding member seen from the interior side and of a section thereof, respectively,

Figs. 3a and 3b are perspective views of a top covering member seen from the interior side and of a section thereof, respectively, and

Figs. 4a and 4b are perspective views of a bottom covering member seen from the interior side and of a section thereof, respectively.

[0020] A roof window 1 mounted in a roof 2 with a covering kit 3 according to the invention is shown in Fig. 1. As may be seen the covering kit comprises a top covering 31, a bottom covering 32, side coverings 34, 35, side claddings 36, a bottom cladding 37, a top flashing 38 and a bottom flashing 39. In the present case the window is centre-hung and the side coverings therefore comprises

an upper member 34 and a lower member 35. In case of a stationary or top-hung window a single longer side covering may be used.

[0021] The side coverings 34, 35 are some of the parts of the covering kit most heavily exposed to precipitation and a satisfactory result may therefore be achieved by providing a sound dampening of these only. Fig. 2 shows a perspective view of the lower side covering 35, seen from the interior side. An adhesive tape 40, which is depicted with a grey colour in the figures, has been applied for sound dampening purposes. In the present embodiment, the adhesive tape has been applied only on the face 351 of the covering member, which is parallel to the window pane in the mounted state (cf. Fig. 1), whereas those faces that are perpendicular to the window pane are left uncovered. This has numerous advantages. Firstly, the amount of adhesive tape used, and thus the material costs, is kept a minimum. Secondly, when the covering is made by deformation of sheet aluminium, the zones affected by the deformation are not covered by the adhesive tape. This means that the adhesive tape may be applied prior to deformation without the risk of being torn by the tools or that it may be applied afterwards without having to be taken around corners, the edge 41 of the tape 40 being substantially aligned with the line, where the side covering member begins to bend. Thirdly, the interior width *d* of the covering member is not affected by the application of adhesive tape on the sides of the covering and it may thus still be fitted over the window side frame member without the need for adaptation of any of them. The standardised sizes of the covering and frame parts may thus be maintained.

[0022] Depending on the mode of application the tape may be taken along the entire length of the lower side covering member 35, thus also covering the part 353 projecting underneath the upper side covering member 34 in the mounted state as depicted in Fig. 1, or it may be terminated at the ends 354, 355 of the flat section 351.

[0023] Holes 356, 357 in the parts of the covering member covered by the adhesive tape are preferably made after the application of the adhesive tape, but it is to be understood that the adhesive tape may also be provided with punched out holes thus allowing it to be applied subsequently.

[0024] The tape shown in Figs. 2-4 is a continuous tape of constant thickness, which is cheap to manufacture and easy to work with. In special circumstances it may, however, be advantageous to use a tape of a more complex design, e.g. made from expanded metal or having local thickenings.

[0025] In the preferred embodiment an acrylic adhesive is used. Such adhesives are well tested and have proven capable of maintaining their strength and elasticity during the expected life span of modern roof windows. Other adhesives may of course also be used. An example of such an adhesive is butyl, which have also proven sufficiently durable. Butyl, however, has to be applied in a thicker layer, which causes problems with most modern

type covering kits, where the space beneath them have been minimised to improve the insulating properties of the window. The use of such alternative adhesive might therefore lead to the need for a modification of the shape of one or more members of the covering kit and thus possibly to the need for new tools or methods of manufacture.

[0026] The adhesive may be applied uniformly or in more complex configurations such as spots, lines or grids.

[0027] When using an adhesive tape consisting of an aluminium tape of a homogeneous configuration and uniform layer of an acrylic adhesive, the tape should preferably have a thickness of 0,05-0,10 mm and the adhesive layer should have a thickness of 0,03-0,07 mm. Tests have shown, that a particularly good sound dampening of covering kit members made from aluminium sheets with thickness of 0,8 mm is achieved with an aluminium tape of 0,07 mm and an adhesive layer of 0,05 mm.

[0028] The covering kit members are usually made by roll forming, where a sheet of aluminium passes between a series of rollers, which bends it appropriately. The force that has to be applied by each roller or pair of rollers depends on the thickness of the aluminium, possible surface coatings etc. In some cases the adhesive tape may not be capable of withstanding these forces, particularly the shearing forces caused by the rotation of the rollers. It will therefore often be advantageous to apply the adhesive tape only in sections of the covering kit member not affected by the roll forming or to apply it after the deformation of the affected areas.

[0029] If wishing to optimise the sound dampening it is, of course, not sufficient to dampen only the side covering members. All surfaces of the covering kit members hit by precipitation should then be dampened. Fig. 3 shows a top covering member 31 for a centre-hung window depicted up-side-down to reveal the adhesive tape 40 applied on the interior side. Here, a relatively narrow strip of adhesive tape has been applied to the face most heavily affected by precipitation, but it is of course also possible to use a wider strip, that may cover the entire interior surface.

[0030] As may be seen the strip of adhesive tape not only covers the relatively wide plane section 311 of the covering member but also extends somewhat over the inclining section 312. This bend 313 may make it difficult to apply the adhesive tape and the application is therefore performed prior to the formation of the bend. The same applies to the bends 314, 315 at the end sections of the covering member.

[0031] Fig. 4 shows a bottom covering member 32 for a centre-hung window, again depicted up-side-down. As may be readily seen the shape of this covering member is somewhat more complicated, than those described above. This covering member thus has to be subjected to a relatively complex deformation, which worsens the problem of tearing of the adhesive tape 40 described

above, even when it is applied only on a flat face 321. In this case it is therefore particularly preferred to apply the adhesive tape after deformation. Alternatively the deformation process may be split in two, with the application of the adhesive tape interposed.

[0032] Other members of the covering kit 3, such as for example the bottom cladding 37, may be sound dampened in a similar fashion as will be apparent to the person skilled in the art.

[0033] As indicated above similar results may be achieved by using a plastic material, which is temporarily given adhesive properties, thus functioning equivalently to the adhesive tape.

[0034] It is to be understood that the thicknesses, materials, methods of application etc. described above are only preferred examples and that they may be modified or combined differently as will be apparent to persons skilled in the art. Similarly it is to be understood, that the examples given are not to be regarded as limiting to the scope of invention, which is defined in the claims.

Claims

1. A method for improving the sound dampening properties of a roof window, which, in the mounted state, penetrates a roof surface, said roof window comprising a pane and at least one frame surrounding the pane, **characterized in that** an adhesive tape is applied to at least one member of a covering kit, which comprises a number of flashing, cladding and covering members and which is used for covering the exterior surfaces of the frame(s) and the joints between the roof surface and outer frame surfaces and between exterior frame surfaces and the pane.
2. A method according to claim 1, **characterized in that** the adhesive tape is applied to all sections of the covering kit members, which are substantially parallel to the pane in the mounted state and which are not covered by roofing material.
3. A method according to claim 1 or 2, **characterized in that** the adhesive tape is applied to an interior surface of the covering kit member(s).
4. A method according to any of the preceding claims, **characterized in that** the adhesive tape is applied during the manufacture of the covering kit member(s).
5. A method according to claim 4, **characterized in that** at least one of the covering kit member(s) is made by deformation of a sheet material and that the adhesive tape is applied prior to deformation.
6. A method according to any of the preceding claims, **characterized in that** the adhesive tape is pre-man-

ufactured.

7. A method according to any of claims 1-5, **characterized in that** the adhesive and the tape is applied in two separate steps. 5
8. A method according to any of the preceding claims, **characterized in that** the adhesive tape is applied substantially over the entire length of the covering kit member(s). 10
9. A method according to any of claims 1-7, **characterized in that** the adhesive tape is applied at discrete sections of the covering kit member(s). 15
10. A covering kit for a roof window, which, in the mounted state, penetrates a roof surface and which comprises a pane and at least one frame surrounding the pane, the covering kit comprising a number of flashing, cladding and covering members and being intended for covering the exterior surfaces of the frame(s) and the joints between the roof surface and outer frame surfaces and between exterior frame surfaces and the pane, **characterized in that** an adhesive tape is attached to at least one member thereof. 20
25
11. A covering kit according to claim 10, **characterized in that** the adhesive tape is attached to an interior surface of the at least one member. 30
12. A covering kit according to claim 10 or 11, **characterized in that** the adhesive tape is attached only to sections facing the exterior in the mounted state. 35
13. A covering kit according to any of claims 10-12, **characterized in that** the adhesive tape extends substantially over the entire length of the at least one member. 40
14. A covering kit according to any of claims 10-12, **characterized in that** the adhesive tape is attached at discrete sections of the at least one member. 45
15. A covering kit according to any of claims 10-14, **characterized in that** the tape is made from the same material as the covering kit member(s). 50
16. A covering kit according to any of claims 10-15, **characterized in that** the adhesive is an acrylic adhesive. 55
17. A covering kit according to any of claims 10-16, **characterized in that** the tape is made from aluminium with a thickness of 0,05-0,10 mm, preferably 0,07 mm, and that the adhesive is an acryl adhesive with a thickness of 0,03-0,07 mm, preferably 0,05 mm.
18. A roof window sound dampened according to any of the claims 1-9 or provided with a covering kit according to any of claims 10-17.

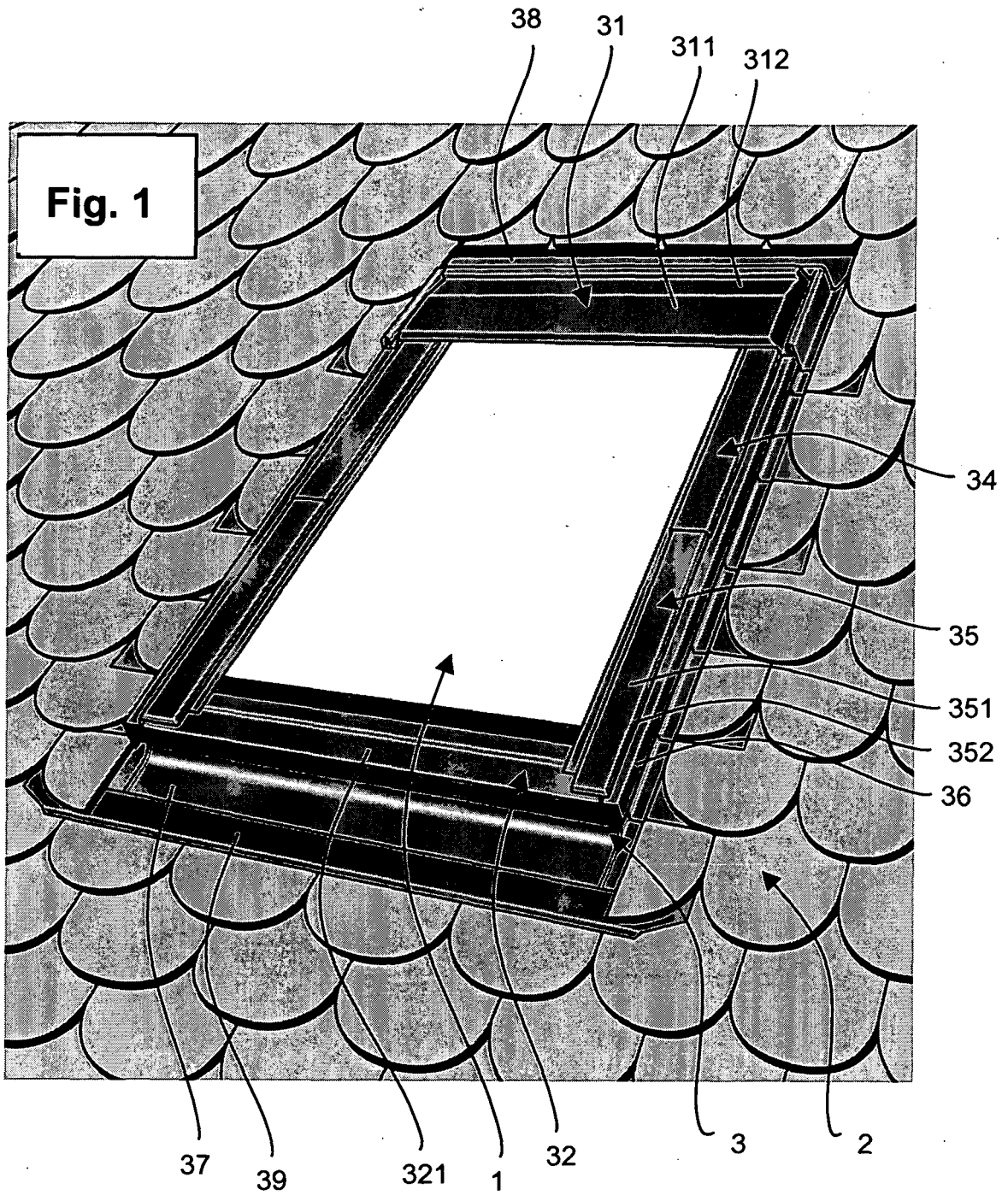

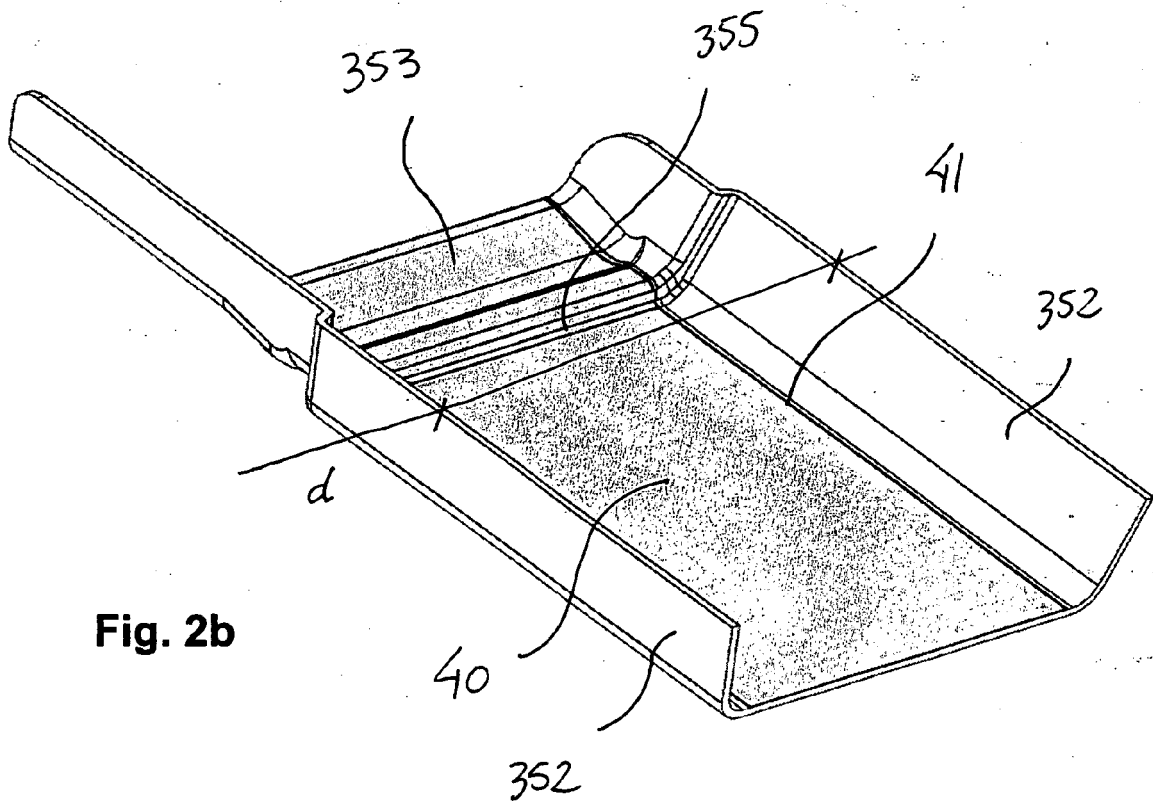
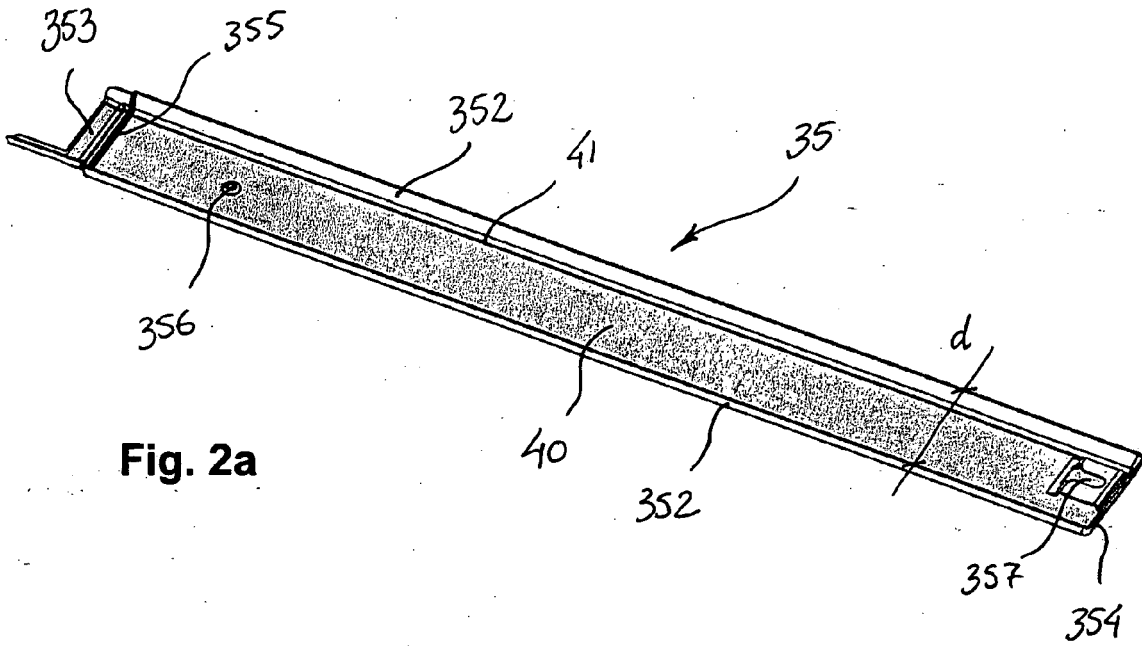

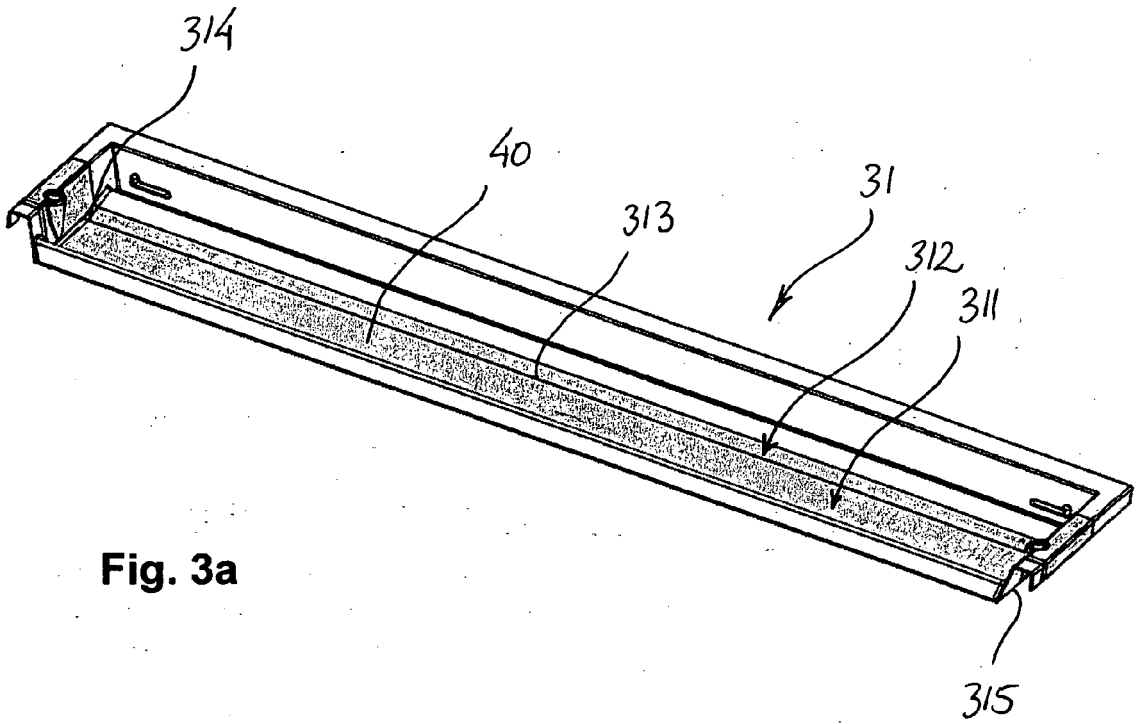

Fig. 3a

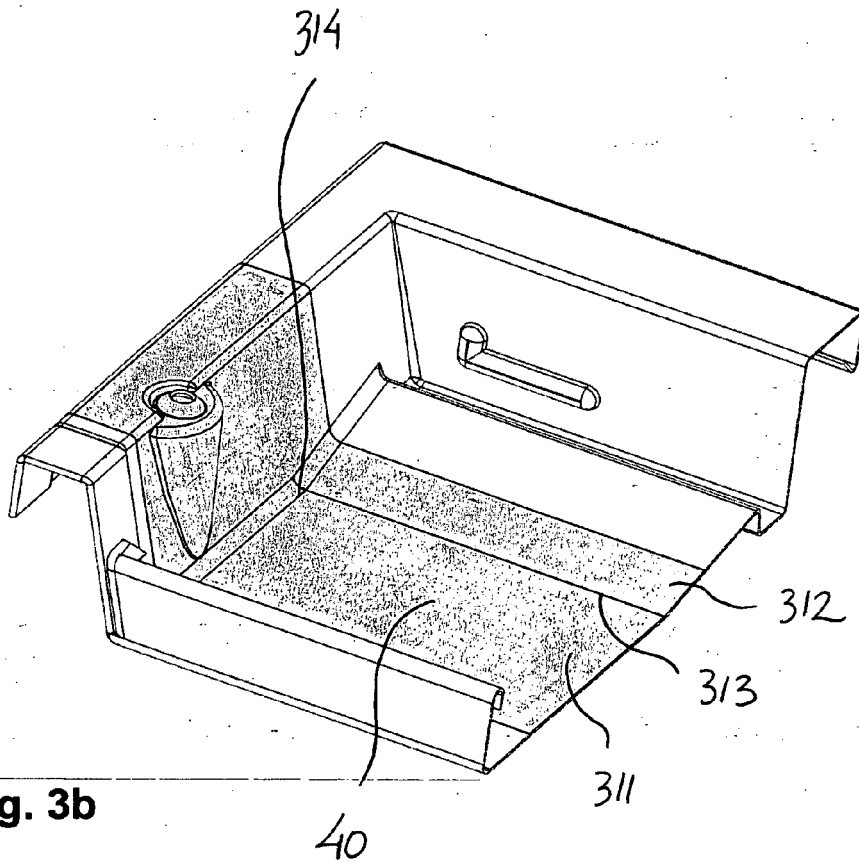

Fig. 3b

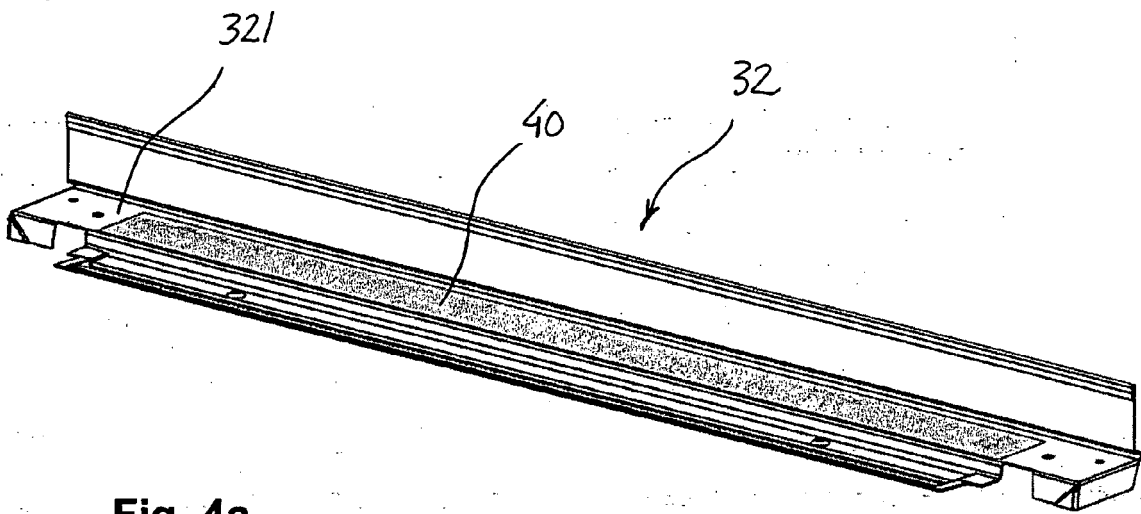

Fig. 4a

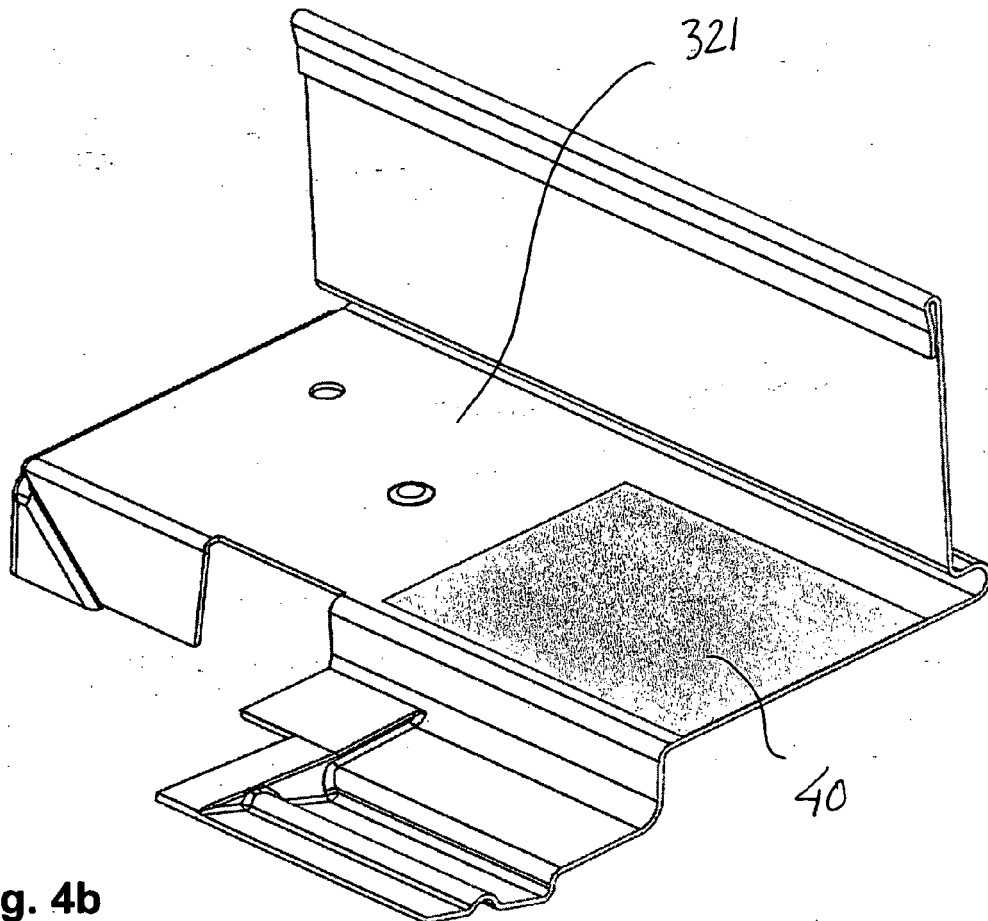

Fig. 4b



DOCUMENTS CONSIDERED TO BE RELEVANT			
Category	Citation of document with indication, where appropriate, of relevant passages	Relevant to claim	CLASSIFICATION OF THE APPLICATION (IPC)
D,A	DE 196 35 463 A1 (HILBERT ENRICO [DE]) 5 March 1998 (1998-03-05) * abstract; figure 1 * -----	1,10	INV. E04D13/03
			TECHNICAL FIELDS SEARCHED (IPC)
			E04D E06B
The present search report has been drawn up for all claims			
Place of search Munich		Date of completion of the search 28 April 2008	Examiner Peschel, Gerhard
CATEGORY OF CITED DOCUMENTS X : particularly relevant if taken alone Y : particularly relevant if combined with another document of the same category A : technological background O : non-written disclosure P : intermediate document		T : theory or principle underlying the invention E : earlier patent document, but published on, or after the filing date D : document cited in the application L : document cited for other reasons & : member of the same patent family, corresponding document	

EPO FORM 1503 03 82 (P04C01)

**ANNEX TO THE EUROPEAN SEARCH REPORT
ON EUROPEAN PATENT APPLICATION NO.**

EP 07 38 8078

This annex lists the patent family members relating to the patent documents cited in the above-mentioned European search report. The members are as contained in the European Patent Office EDP file on
The European Patent Office is in no way liable for these particulars which are merely given for the purpose of information.

28-04-2008

Patent document cited in search report	Publication date	Patent family member(s)	Publication date
DE 19635463	A1	NONE	

EPC FORM P0459

For more details about this annex : see Official Journal of the European Patent Office, No. 12/82

REFERENCES CITED IN THE DESCRIPTION

This list of references cited by the applicant is for the reader's convenience only. It does not form part of the European patent document. Even though great care has been taken in compiling the references, errors or omissions cannot be excluded and the EPO disclaims all liability in this regard.

Patent documents cited in the description

- DE 19635463 [0004]