

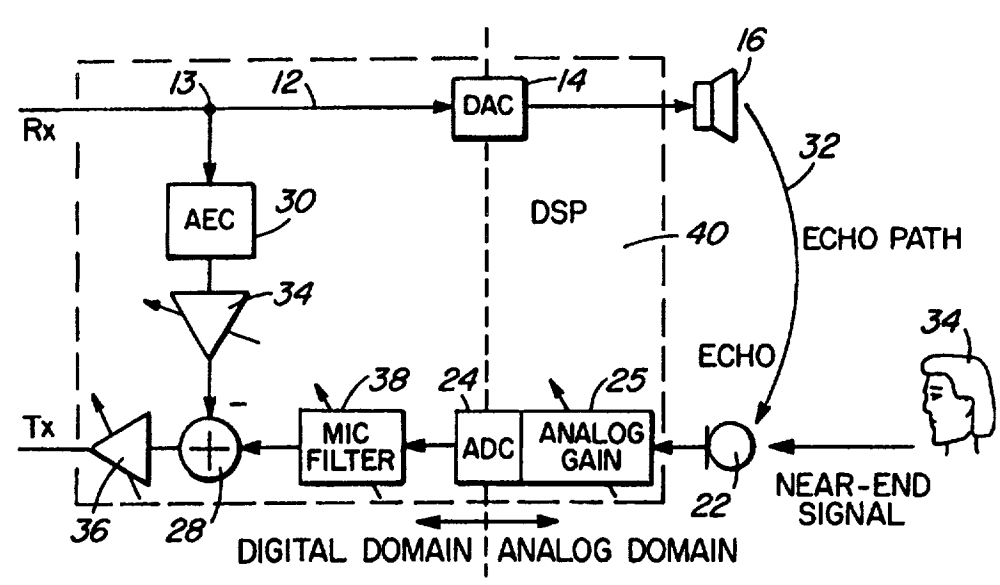

INTERNATIONAL APPLICATION PUBLISHED UNDER THE PATENT COOPERATION TREATY (PCT)

| | | |
|--|------------------|---|
| <p>(51) International Patent Classification ⁶ : H04M 1/60</p> | <p>A2</p> | <p>(11) International Publication Number: WO 98/07263 (43) International Publication Date: 19 February 1998 (19.02.98)</p> |
| <p>(21) International Application Number: PCT/CA97/00579 (22) International Filing Date: 8 August 1997 (08.08.97) (30) Priority Data: 08/694,124 8 August 1996 (08.08.96) US (71) Applicant: NORTHERN TELECOM LIMITED [CA/CA]; World Trade Center of Montreal, 8th floor, 380 St. Antoine Street West, Montreal, Quebec H2Y 3Y4 (CA). (72) Inventors: MCCLENNON, Scott; 209 Chandler Avenue, Ottawa, Ontario K2C 0G3 (CA). DING, Heping; 29 Rothesay Drive, Kanata, Ontario K2L 1N6 (CA). DAL FARRA, David; 19 Hallowell Court, Nepean, Ontario K2H 8N4 (CA). (74) Agent: FORTIN, Jean-Pierre; Northern Telecom Limited, Patent Dept., P.O. Box 3511, Station "C", Ottawa, Ontario K1Y 4H7 (CA).</p> | | <p>(81) Designated States: AL, AM, AT, AU, AZ, BA, BB, BG, BR, BY, CA, CH, CN, CU, CZ, DE, DK, EE, ES, FI, GB, GE, GH, HU, IL, IS, JP, KE, KG, KP, KR, KZ, LC, LK, LR, LS, LT, LU, LV, MD, MG, MK, MN, MW, MX, NO, NZ, PL, PT, RO, RU, SD, SE, SG, SI, SK, SL, TJ, TM, TR, TT, UA, UG, UZ, VN, YU, ZW, ARIPO patent (GH, KE, LS, MW, SD, SZ, UG, ZW), Eurasian patent (AM, AZ, BY, KG, KZ, MD, RU, TJ, TM), European patent (AT, BE, CH, DE, DK, ES, FI, FR, GB, GR, IE, IT, LU, MC, NL, PT, SE), OAPI patent (BF, BJ, CF, CG, CI, CM, GA, GN, ML, MR, NE, SN, TD, TG). Published <i>Without international search report and to be republished upon receipt of that report.</i></p> |

(54) Title: DYNAMIC OPTIMIZATION OF HANDSFREE MICROPHONE GAIN



(57) Abstract
A system and method for dynamically optimizing the analog gain for a microphone in a telephone terminal operable in handsfree mode. The system makes use of a process whereby a relatively inexpensive analog to digital converter is used to meet gain requirements so as to accommodate the loudest echo through transmit path while maintaining an acceptable signal to noise ratio for the quietest talker. The system digital signal processor in conjunction with speech activity detection means is used to provide an optimum microphone gain under all circumstances.

FOR THE PURPOSES OF INFORMATION ONLY

Codes used to identify States party to the PCT on the front pages of pamphlets publishing international applications under the PCT.

| | | | | | | | |
|----|--------------------------|----|--|----|--|----|--------------------------|
| AL | Albania | ES | Spain | LS | Lesotho | SI | Slovenia |
| AM | Armenia | FI | Finland | LT | Lithuania | SK | Slovakia |
| AT | Austria | FR | France | LU | Luxembourg | SN | Senegal |
| AU | Australia | GA | Gabon | LV | Latvia | SZ | Swaziland |
| AZ | Azerbaijan | GB | United Kingdom | MC | Monaco | TD | Chad |
| BA | Bosnia and Herzegovina | GE | Georgia | MD | Republic of Moldova | TG | Togo |
| BB | Barbados | GH | Ghana | MG | Madagascar | TJ | Tajikistan |
| BE | Belgium | GN | Guinea | MK | The former Yugoslav Republic of Macedonia | TM | Turkmenistan |
| BF | Burkina Faso | GR | Greece | | | TR | Turkey |
| BG | Bulgaria | HU | Hungary | ML | Mali | TT | Trinidad and Tobago |
| BJ | Benin | IE | Ireland | MN | Mongolia | UA | Ukraine |
| BR | Brazil | IL | Israel | MR | Mauritania | UG | Uganda |
| BY | Belarus | IS | Iceland | MW | Malawi | US | United States of America |
| CA | Canada | IT | Italy | MX | Mexico | UZ | Uzbekistan |
| CF | Central African Republic | JP | Japan | NE | Niger | VN | Viet Nam |
| CG | Congo | KE | Kenya | NL | Netherlands | YU | Yugoslavia |
| CH | Switzerland | KG | Kyrgyzstan | NO | Norway | ZW | Zimbabwe |
| CI | Côte d'Ivoire | KP | Democratic People's Republic of Korea | NZ | New Zealand | | |
| CM | Cameroon | | | PL | Poland | | |
| CN | China | KR | Republic of Korea | PT | Portugal | | |
| CU | Cuba | KZ | Kazakistan | RO | Romania | | |
| CZ | Czech Republic | LC | Saint Lucia | RU | Russian Federation | | |
| DE | Germany | LJ | Liechtenstein | SD | Sudan | | |
| DK | Denmark | LK | Sri Lanka | SE | Sweden | | |
| EE | Estonia | LR | Liberia | SG | Singapore | | |

DYNAMIC OPTIMIZATION OF HANDSFREE MICROPHONE GAINField of the Invention

This invention relates to telephone terminals
5 operable in handsfree mode and to a method and system for
dynamically optimizing the microphone gain of such terminals
so as to accommodate echo and maintain an acceptable signal
to noise ratio.

10 Background of the Invention

It is common for modern telephone terminals to be
operable in handsfree mode. Such terminals have a
loudspeaker and a microphone to permit communication with a
far end user without having to hold the handset close to
15 one's ear. A significant problem with such a system is an
echo signal which results from a portion of the received
signal broadcast by the loudspeaker being picked up by the
microphone and retransmitted back to the far end user. This
echo, if not controlled, can be very annoying to the far end
20 user.

In order to reduce the amount of this echo signal
heard by the far end user, acoustic echo cancellers (AECs)
have been employed. An AEC makes an estimate of the echo
25 signal and subtracts the estimated amount from the
microphone signal which contains both unwanted echo and the
wanted near end signal as generated by the near end user.
This technique reduces the echo signal in the transmit path
while leaving the wanted near end signal intact.

30
Measurements and calculations show that, because
of the strong acoustic coupling between the loudspeaker and
the microphone on a typical desktop handsfree platform, the
level of the near end signal at the microphone could be as
35 much as 50 dB lower than the level of the loudest echo
there. The value of 50 dB below the loudest echo is for the
average of the quietest talkers measured.

The analog gain, which is the gain introduced to the near end signal and echo in the analog domain, must be such that the full dynamic range of the amplifier is reached and not exceeded by the loudest possible echo. This is required so that the analog to digital converter following the analog gain produces an undistorted and full scale digital version of the echo. Such an analog gain will then result in a level of the near end signal that could be as much as 50 dB (again for the quietest talker) lower than the full scale in the digital domain.

Based on performance requirements and Integrated Services Digital Network (ISDN) set specifications, the minimum signal to noise ratio (SNR) is 44 dB. Thus, taking into consideration the previously discussed echo levels, the analog to digital converter for the system needs to have a noise floor that is $50 + 44 = 94$ dB below its full scale.

Although sophisticated analog to digital converters can satisfy this requirement, they do so at substantial cost. A typical low-cost device, such as a Crystal Semiconductor Corporation's CS 4216 has a noise floor of 80 dB, i.e., 14 dB too low to meet the requirements set out above.

Summary of the Invention

It is therefore an object of the present invention to provide a technique which will accommodate the loudest echo and maintain a sufficient signal-to-noise ratio for the quietest talker while using a low-cost analog to digital converter in a telephone terminal operating in handsfree mode.

Therefore, in accordance with a first aspect of the present invention, there is provided a telephone terminal operable in handsfree mode having a receive path

with a digital to analog converter and a loudspeaker; a transmit path having an analog to digital converter with an analog signal amplifier and a microphone; an acoustic echo canceller communicatively coupled between the receive path
5 and the transmit path; detector means to monitor speech activity on respective paths and; processing means responsive to the detector means. The improvement according to the invention comprises means to dynamically control the analog amplifier in dependence on speech activity.

10

In accordance with a second aspect of the invention there is provided a method of dynamically controlling the analog gain for a microphone in an audio system of a telephone terminal operable in handsfree mode
15 wherein the audio system comprises a receive path having a digital to analog converter and a loudspeaker; a transmit path having a microphone and an analog to digital converter with controllable amplifier means; an acoustic echo canceller operatively coupled between respective paths; and
20 processing means having detector means to determine speech activity on respective paths. The method according to the present invention comprising (a) setting an analog gain target, (b) determining whether the actual gain meets the gain target, and (c) dynamically adjusting gain as necessary
25 to meet the target in dependence on speech activity on respective paths.

Brief Description of the Drawings

The invention will now be described in greater
30 detail with reference to the attached drawings wherein:

FIGURE 1 is a simplified block diagram of the audio system of a typical handsfree terminal;

FIGURE 2 is a simplified block diagram of the audio system including dynamic gain according to the present
35 invention;

FIGURES 3A - 3D graphically illustrate the analog gain adjustment relative to time for various components of the system; and

FIGURE 4 is a flow diagram for the analog gain change and digital compensation.

Detailed Description of the Invention

The block diagram of FIGURE 1 shows the acoustic subsystem of a handsfree terminal having an acoustic echo canceller. As shown the subsystem includes a receive path 12 by means of which a communications signal from a far end user is accepted. The signal in digital form is converted to analog via D/A converter 14. The resulting analog signal is received by loudspeaker 16 wherein it is broadcast into the acoustic medium surrounding the speaker.

The transmit path 20 includes microphone 22 and analog to digital converter 24. Associated with A/D converter 24 is amplifier 25 for amplifying the microphone signal in the analog domain. In the digital domain, the signal is filtered by microphone filter 26. An acoustic echo canceller 30 is connected between the receive path 12 at node 13 and the transmit path 20 at subtractor 28. The signal at the output of subtractor 28 is transmitted towards the far end user (not shown).

As shown in FIGURE 1, having traveled through the acoustic media along echo path 32, a portion of the far end signal broadcast by loudspeaker 16 is picked up by microphone 22. Also shown in FIGURE 1 is near end user 34 who is communicating with the far end user via microphone 22 and speaker 16.

The portion of the broadcast signal picked up by the microphone is known as an echo and, if permitted to reach the far end would be annoying. In order to reduce the amount of echo heard by the far end user, an estimate of

the echo is made by the acoustic echo canceller (AEC) 30 and this amount is subtracted from the microphone signal. This technique reduces the echo in the transmit path while leaving the signal attributable to the near end user intact.

5 As indicated previously, the loudest echo in the microphone signal may be 50 dB higher than the signal generated by a quiet talking near end user. In order to accommodate this echo level and to maintain an acceptable signal to noise ratio for the quietest talker while still using a low cost

10 analog amplifier, the present invention provides a concept of dynamically optimizing the signal level in the analog domain in all circumstances.

The invention takes into consideration the

15 following factors:

- (1) The analog gain does not have to be small enough to accommodate the loudest echo when there is little echo. This way, the analog gain can be

20 increased to increase the dynamic range of the quietest talker in the digital domain, so as to increase the signal to noise ratio (SNR) with a constant amplifier noise floor.

- (2) The analog gain must be minimized to accommodate the echo when there is one. Although the SNR for the quietest talker under this circumstance is lower than required, the effect of the poor SNR is masked by the residual echo of the AEC and

25 therefore will not be perceived by the far-end party.

30

A simplified block diagram of the acoustic subsystem incorporating the invention is shown in FIGURE 2.

35 For the sake of clarity, components not directly affected by the invention are not shown in this figure. Those elements which are the same as those shown in FIGURE 1 carry the same

reference numerals. It can be seen from FIGURE 2 that, in addition to the analog gain 25, there are three other adjustable elements, namely, an AEC output scaler 34; a transmit scaler 36; and the microphone filter's internal storage units 38.

Dynamically adjusting the analog gain results in variations in the echo path's gain as well as the transmit signal's gain in the digital domain. Thus, the AEC output and transmit signal must be dynamically scaled accordingly. These operations must be synchronous with the level changes at the corresponding point in the signal path in order to minimize the artifacts associated with the whole exercise.

FIGURE 3A-3D show graphically the relationship between the microphone output and the scaling of the microphone filter's output when an analog gain increase is instructed. FIGURE 3A is a representation of the microphone output as a function of time. The analog gain of the ADC amplifier, for example, a one with CS4216, will not change immediately upon receipt of instructions to do so - time t_0 in FIGURE 3A. The analog gain increases in conjunction with a zero-crossing in its input, i.e., time t_1 . This is shown in FIGURE 3B. The effect of the analog gain change does not show up in the digital domain until a fixed amount of time (Δ) later at t_2 . As shown in FIGURE 3C, $\Delta = t_2 - t_1$. The presence of the microphone filter further complicates the problem; being a recursive filter, its output is scaled gradually upon a change in input scaling. This is shown in FIGURE 3D. The delay and gradual change effects of the microphone filter's output have to be taken into consideration in the implementation of the invention.

As shown in FIGURE 2, the acoustic system for dynamically optimizing the microphone gain includes variable elements which are controlled by the system's digital signal processor. The control, which takes into consideration

speech activity through respective paths, is such that the gain of the controlled elements is only provided when such gain is needed to meet the signal to noise ratio requirements for a quiet talker while accommodating the
5 loudest echo.

The control is based on the establishment of an analog gain target. This target takes into consideration the requirements of the acoustic system as a function of
10 speech activity in respective signal paths. Once the analog gain target is set the digital signal processor starts to coordinate the analog gain change and digital compensation by following the steps shown in FIGURE 4 until the actual analog gain reaches the preset target.

15

In FIGURE 4, Step 1 involves the establishment of a new analog gain target based on the system requirements. If the actual analog gain equals the target then nothing further is done until the next new target is set. If the
20 actual gain does not meet the target the DSP sends a control word to the analog amplifier to instruct an analog gain change of 1.5 dB. The reason why such a small step size is used is to minimize the artifacts of the adjustment that might be heard at the far end. The DSP then waits for Δ ms,
25 Δ ms being the delay shown in FIGURE 3C. After the delay of Δ ms, the time it takes for a signal to propagate from the analog amplifier input to the output of the analog to digital converter, the DSP waits for a zero crossing in the analog to digital converter's output. This is the point in
30 time when the analog gain change begins to show up in the digital domain. Once a zero-crossing is detected, which means an analog gain change was made at this signal point, the DSP starts to perform a series of digital compensations (Steps 6, 7 and 8 in FIGURE 4).

35

The contents in the microphone filter's all internal signal storage elements, i.e., the signals in the

tapped delay lines in BI-QUAD sections of the filter are all scaled by the same amount as that of the analog gain change. This establishes an implied history so that it looks as if the analog gain had always been at this new value. The application of this technique replaces the 'gain ramp' shown in FIGURE 3D with a simple step gain change, so that it becomes straightforward to perform the remaining digital compensations (Steps 7 and 8).

10 Since the microphone filter output has been scaled, the acoustic echo canceller's output must be scaled (Step 7 in FIGURE 4) by the same amount to match the former. This eliminates any possible uncanceled echo resulting from the microphone filter output scaling. Again, since the microphone filter output has been scaled, the transmit signal must be scaled by the same amount but in the opposite direction in order to counterbalance the effect of the microphone filter output scaling (Step 8).

20 Upon completion of Steps 3 to 8 in FIGURE 4, a 1.5 dB change in the analog gain and in digital compensations has been completed. If these changes do not result in the analog gain target being met, more 1.5 dB charges are made until the actual analog gain matches the analog gain target. Once the analog gain target is reached, the task for analog gain change and the subsequent digital compensations is completed.

30 The present invention can be applied in handsfree telephone terminals which have an acoustic echo canceller. The concept is to dynamically optimize the analog gain for the microphone so that it is possible to achieve a good perceptual signal to noise ratio of the transmit signal with a low-cost ADC.

35 While a particular embodiment of the invention has been described and illustrated, it will be apparent to one

skilled in the art that numerous variations and alternatives are possible. The actual scope of the invention is limited only by the appended claims.

WE CLAIM:

1. A telephone terminal operable in handsfree mode having a receive path with a digital to analog converter and a loudspeaker; a transmit path having an analog to digital converter, an analog signal amplifier and a microphone; an acoustic echo canceller communicatively coupled between the receive path and transmit path; detector means to monitor speech activity on respective paths; and a processing means responsive to said detector means, the improvement comprising means to dynamically control the analog amplifier in dependence on speech activity.

2. A telephone terminal as defined in claim 1, said means to dynamically control the analog gain comprising an acoustic echo canceller scaler; a transmit scaler and; an adjustable microphone filter.

3. A telephone terminal as defined in claim 2 wherein said processing means is a system digital signal processor.

4. A telephone terminal as defined in claim 3, said digital signal processor having means to select an analog gain target based on speech activity.

5. A telephone terminal as defined in claim 4 wherein said analog gain is dynamically adjusted to meet said analog gain target.

6. A method of dynamically controlling the analog gain for a microphone in an audio system of a telephone terminal operable in handsfree mode, said audio system comprising a receive path having a digital to analog converter and a loudspeaker, a transmit path having a microphone and an analog to digital converter having controllable analog amplifier means, an acoustic echo

canceller operatively connected between respective paths, and processing means having detection means to determine speech activity on respective paths, the method comprising:

- (a) setting an analog gain target;
- 5 (b) determining whether the actual gain of the amplifier meets the gain target; and
- (c) dynamically adjusting the amplifier gain in order to meet the gain target.

10 7. A method as defined in claim 6 wherein the analog gain is adjusted in discrete steps.

8. A method as defined in claim 7 wherein the step size is 1.5 dB.

15

9. A method as defined in claim 8 wherein said acoustic echo canceller and signal level in said transmit path are adjusted synchronously with said analog gain.

20 10. A method as defined in claim 9 wherein said analog gain step adjustments are repeated until said analog gain target is met.

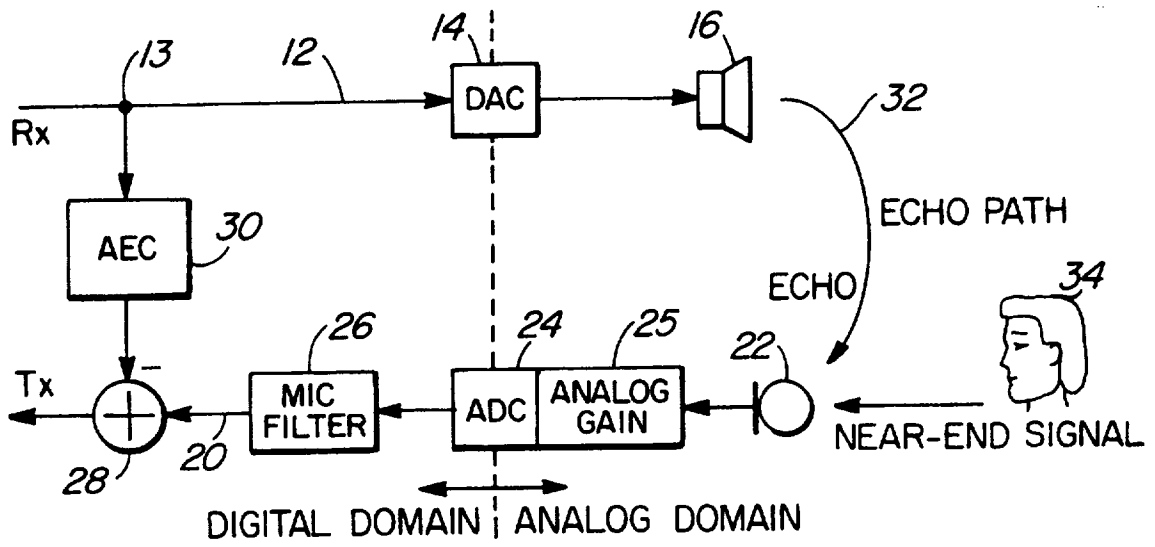

FIG. 1

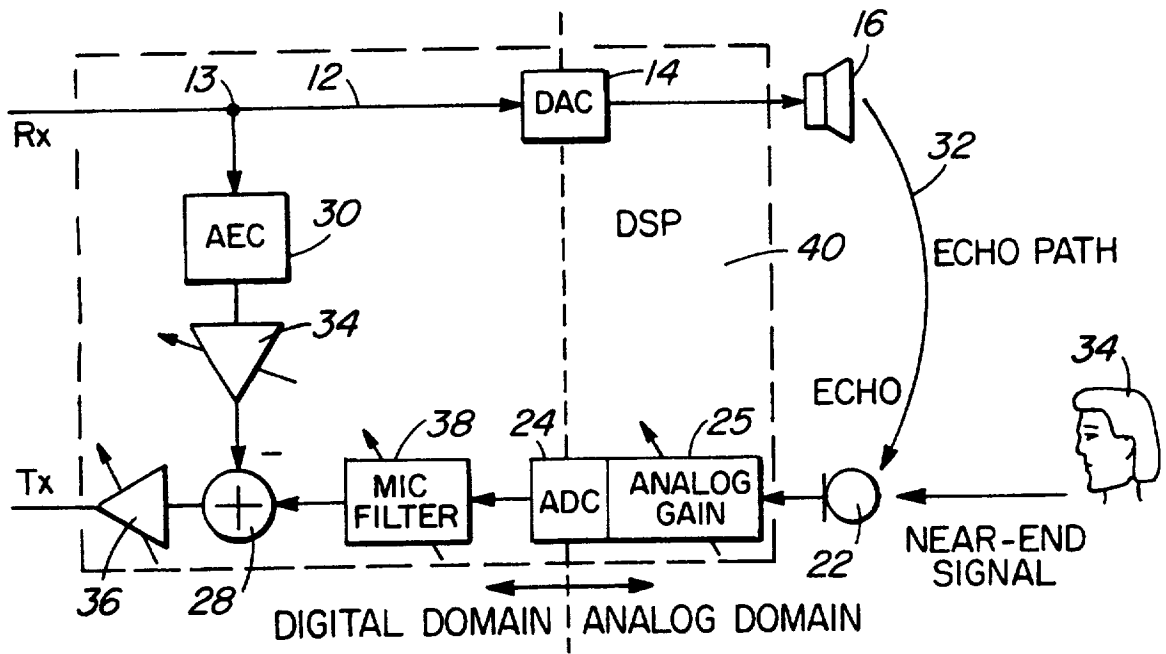

FIG. 2

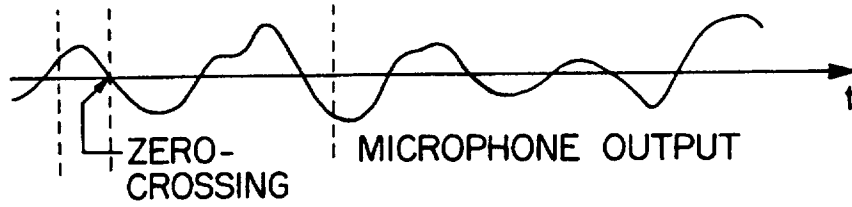

FIG. 3A

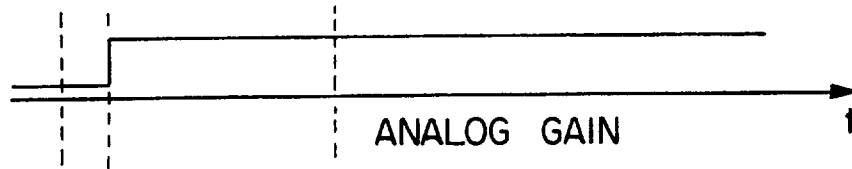

FIG. 3B

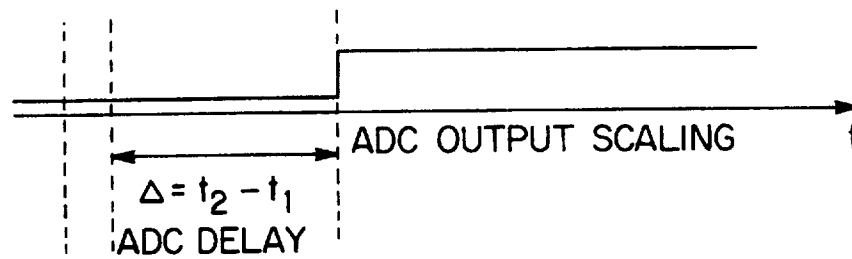

FIG. 3C

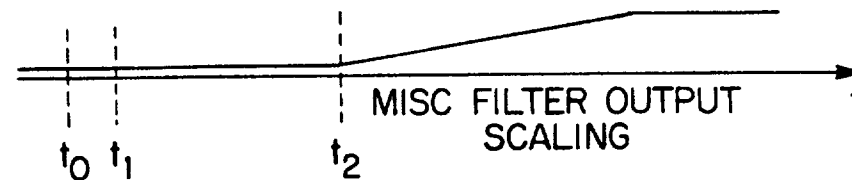

FIG. 3D

3/3

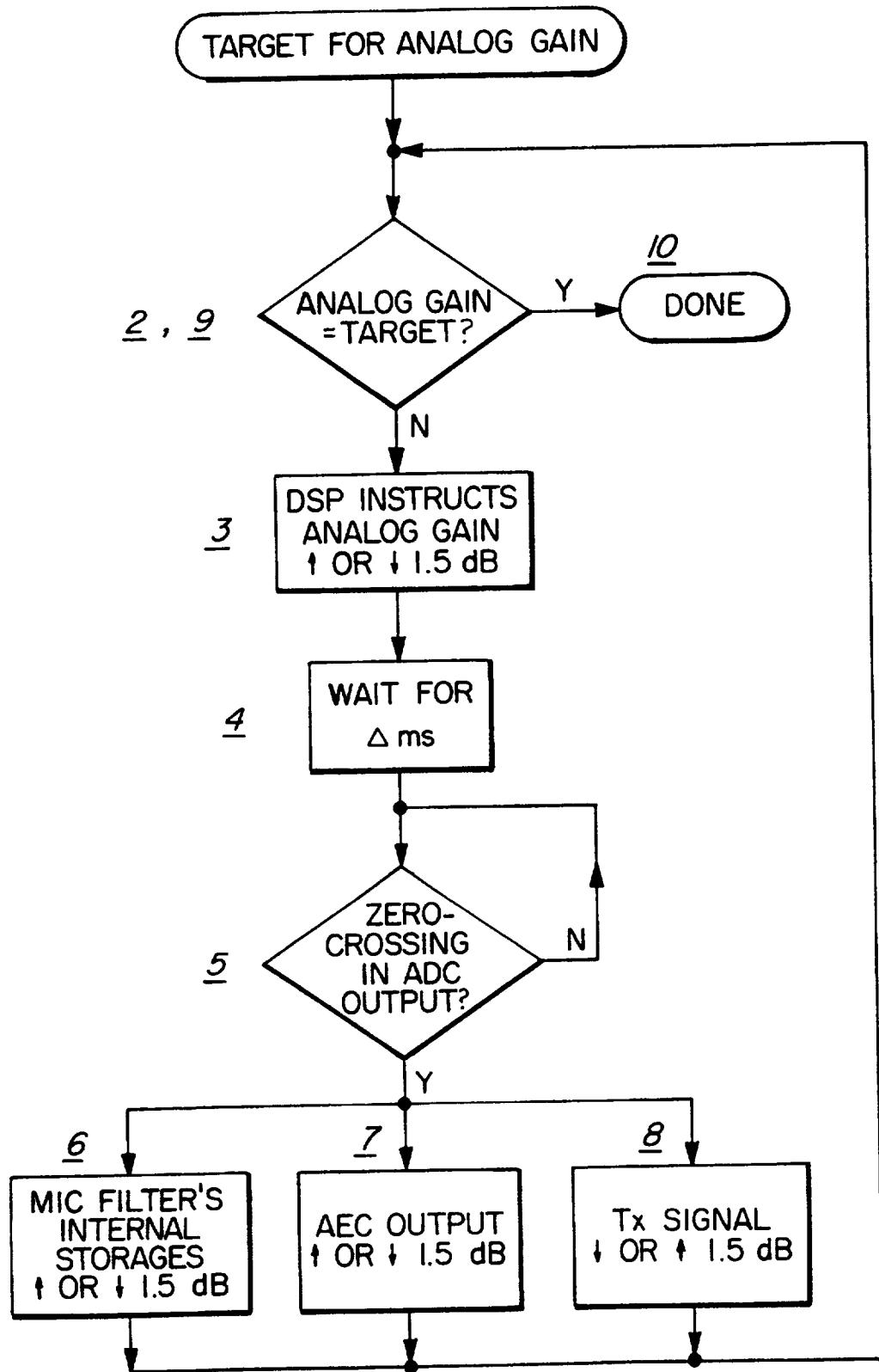

FIG. 4