



INTERNATIONAL APPLICATION PUBLISHED UNDER THE PATENT COOPERATION TREATY (PCT)

| | | |
|---|-----------|---|
| (51) International Patent Classification⁵ : B01L 3/00, B65D 1/04, 41/02 | A1 | (11) International Publication Number: WO 92/04978 (43) International Publication Date: 2 April 1992 (02.04.92) |
| (21) International Application Number: PCT/US91/07006 (22) International Filing Date: 25 September 1991 (25.09.91) (30) Priority data: 588,286 26 September 1990 (26.09.90) US 686,125 15 April 1991 (15.04.91) US 697,694 9 May 1991 (09.05.91) US 719,312 21 June 1991 (21.06.91) US (60) Parent Applications or Grants (63) Related by Continuation US 588,286 (CIP) Filed on 26 September 1990 (26.09.90) US 686,125 (CIP) Filed on 15 April 1991 (15.04.91) US 697,694 (CIP) Filed on 9 May 1991 (09.05.91) US 719,312 (CIP) Filed on 21 June 1991 (21.06.91) (71) Applicant (for all designated States except US): CRYO-CELL INTERNATIONAL, INC. [US/US]; 1900 Grand Avenue, Baldwin, NY 11510 (US). | | (72) Inventors; and (75) Inventors/Applicants (for US only) : RICHARD, Daniel, D. [US/US]; 305 Rim Shadows Drive, Sedona, AZ 86336 (US). KNIPPSCHEER, Herman [DE/US]; 2815 Carnation Avenue, Baldwin, NY 11510 (US). KNAUER, Joseph [US/US]; 165 Whinston Drive, Monticello, NY 12701 (US). (74) Agent: SUDOL, R., Neil; Coleman & Sudol, 71 Broadway, Suite 1201, New York, NY 10006 (US). (81) Designated States: AT, AT (European patent), AU, BB, BE (European patent), BF (OAPI patent), BG, BJ (OAPI patent), BR, CA, CF (OAPI patent), CG (OAPI patent), CH, CH (European patent), CI (OAPI patent), CM (OAPI patent), CS, DE, DE (European patent), DK, DK (European patent), ES, ES (European patent), FI, FR (European patent), GA (OAPI patent), GB, GB (European patent), GN (OAPI patent), GR (European patent), HU, IT (European patent), JP, KP, KR, LK, LU, LU (European patent), MC, MG, ML (OAPI patent), MN, MR (OAPI patent), MW, NL, NL (European patent), NO, PL, RO, SD, SE, SE (European patent), SN (OAPI patent), SU+, TD (OAPI patent), TG (OAPI patent), US. Published <i>With international search report. Before the expiration of the time limit for amending the claims and to be republished in the event of the receipt of amendments.</i> |
| (54) Title: METHOD FOR USE IN PREPARING BIOLOGICAL SAMPLES AND RELATED STORAGE RECEPTACLE | | |
| (57) Abstract A method for use in preparing biological samples comprises the steps of (a) upon the birth of an infant, obtaining at least a portion of a placenta and an associated umbilical cord which extended from the infant to the placenta, (b) extracting a first biological specimen from the portion of the placenta and umbilical cord and (c) extracting a second biological specimen from the umbilical cord/placenta or from a parent of the infant. The first biological specimen is deposited in one chamber of a storage receptacle having a plurality of storage chambers, while the second biological specimen is deposited in another of the chambers. The receptacle is then subjected to storage. The biological specimens are preferably blood fluid or DNA. A vial assembly for use in the method comprises a plurality of modular storage units each connected one to the other by cooperating male and female connectors. Alternatively, the vial assembly comprises a vial with multiple discrete ampules inside the vial or by partition inserts having the same transverse cross-section as the cavity defined by the vial. The vial may be further provided with a separate removable flange. | | |

+ DESIGNATIONS OF "SU"

Any designation of "SU" has effect in the Russian Federation. It is not yet known whether any such designation has effect in other States of the former Soviet Union.

FOR THE PURPOSES OF INFORMATION ONLY

Codes used to identify States party to the PCT on the front pages of pamphlets publishing international applications under the PCT.

| | | | | | |
|----|--------------------------|----|--|-----------------|--------------------------|
| AT | Austria | ES | Spain | MG | Madagascar |
| AU | Australia | FI | Finland | ML | Mali |
| BB | Barbados | FR | France | MN | Mongolia |
| BE | Belgium | GA | Gabon | MR | Mauritania |
| BF | Burkina Faso | GB | United Kingdom | MW | Malawi |
| BG | Bulgaria | GN | Guinea | NL | Netherlands |
| BJ | Benin | GR | Greece | NO | Norway |
| BR | Brazil | HU | Hungary | PL | Poland |
| CA | Canada | IT | Italy | RO | Romania |
| CF | Central African Republic | JP | Japan | SD | Sudan |
| CG | Congo | KP | Democratic People's Republic of Korea | SE | Sweden |
| CH | Switzerland | KR | Republic of Korea | SN | Senegal |
| CI | Côte d'Ivoire | LI | Liechtenstein | SU ⁺ | Soviet Union |
| CM | Cameroon | LK | Sri Lanka | TD | Chad |
| CS | Czechoslovakia | LU | Luxembourg | TG | Togo |
| DE | Germany | MC | Monaco | US | United States of America |
| DK | Denmark | | | | |

**METHOD FOR USE IN PREPARING BIOLOGICAL SAMPLES
AND RELATED STORAGE RECEPTACLE**

Field of the Invention

This invention relates to a method for preparing biological samples. More particularly, this invention relates to a method for preparing two or more related biological samples. The invention also relates to a storage receptacle, e.g., a vial assembly, usable in performing the method. The vial assembly has multiple storage capabilities.

Background of the Invention

In the medical field, it is frequently necessary to take multiple tissue or fluid samples from patients. For example, blood and urine samples may be required, or just several blood samples, for the performance of different diagnostic tests. Under current practice, the samples are placed in respective test tubes for transport to laboratory sites. Each test tube must be labeled separately with identifying information. This separate labeling results in an increase in the expenditures of time and effort relative to that required where the labeling is performed only once. In addition, the use of different test tubes for storage and transport increases the likelihood of confusion in the identification of the contents of the different test tubes.

Frequently, the tests are done in the same laboratory. Or else the samples are stored for use at different times.

As disclosed in U.S. Patent No. 5,022,236, a cryogenic storage unit for storing large numbers of specimens in separate vials requires vials with support flanges. The vials are received in apertures on support bars which move along a predetermined path in a housing chamber. It has been discovered that most specimen-storage vials currently on the market comprise cylindrical test-tube type receptacles with a cap members. These vials have no flanges. It would be desirable to provide such vials with support flanges.

As disclosed in commonly owned International Patent Application No. PCT/US90/07583, filed December 20, 1990, the contents of umbilical cords may be used for diagnosis, therapy and identification. More particularly, the umbilical cord blood is useful for treating bone marrow deficiencies and possibly in genetic treatments.

- 2 -

The human umbilical cord reaches a length of 35 to 50 cm at term and includes two umbilical arteries and a single umbilical vein. The vein carries oxygenated blood from the placenta to the fetus. The arteries and the vein are embedded in a mucous connective tissue in turn covered by an epithelium which is multilayered at birth. The connective tissue includes interlacing bundles of collagen fibers having intercellular spaces filled with a gelatinous substance known as Wharton's jelly. The cells of the connective tissue are a primitive form of fibroblast, have easily detectable nuclei and are rich in collagen. The umbilical arteries have relatively thick muscular walls containing a diffuse network of elastic fibers.

In many instances, the umbilical cord, like the placenta, is discarded after birth. However, it has been discovered that at least certain constituents of the umbilical cord may have a special usefulness. In a recent advance in the treatment of bone marrow defects in infants, physicians used the blood cells from the umbilical cord of an infant to aid in the regeneration of the stem cells in an older sibling. The blood was separated from the umbilical cord, subsequently frozen, and stored for seven months prior to infusion. Upon thawing, the cells were intravenously infused into the body of the recipient youngster. This technique provides several advantages over conventional marrow transplantation. Using the cord blood in this instance enabled transplant as soon as a compatible sibling was born, while candidates for marrow transplant generally must wait until the newborn is at least six months old. In addition, the procedure eliminates for the donor the pain of marrow extraction.

Other uses for constituents of the human umbilical cord have been instated. For example, in the article "Differential Prostacyclin Production by Human Umbilical Vasculature" by John H. Harold et al., Archive of Pathological Laboratory Medicine, Vol, 112, pp. 43-46 (January 1988), the authors point out that the human umbilical cord provides an easily accessible source of human vascular tissue.

Conventional methods for identifying or confirming the identities of people are based on such individual indicia as fingerprints and tooth morphology. Newer techniques

- 3 -

involve voice prints and retinal structure. All of these conventional methods can provide information about who an individual is. Information as to the biological, histological, and biochemical constituents of a person may be obtained from the person's umbilical cord upon the birth of the person.

Another recently developed identification technique is based on the composition of genetic material. U.S. Patents Nos. 4,772,549 and 4,861,708 to Philippe M. Frossard, for example, disclose methods for determining the genetic identity of an individual human subject. The former patent in particular describes and claims a method comprising the steps of extracting DNA from the somatic cells of the human subject, digesting the extracted DNA with a selected restriction enzyme, and examining the digested DNA for polymorphisms from a preselected grouping, wherein the polymorphisms are defined by the presence or absence of a DNA fragment of known length which hybridizes to any one of several predetermined probes or their equivalents.

Other methods for genetic typing and identification are known and have been sufficiently developed to enable a determination of parentage from comparison of a child's DNA material with that of possible fathers.

Cryogenic preservation techniques have advanced sufficiently to enable the long term storage of genetic materials. Vivigen, Inc., a company in Santa Fe, New Mexico, has announced that it is commencing the cryogenic storage of DNA and RNA for medical and research purposes. This firm, along with other companies currently storing DNA are currently storing diseased cells only.

Clearly, umbilical or fetal blood and DNA from a newly born infant have great potential usefulness for the individual. However, it is to be noted that the long term storage and retrieval of stored blood and DNA present substantial difficulties in proper identification and recognition of the stored samples. Such identification is prone to error arising from inadequacies in recordation and locating stored specimens.

It is to be noted, moreover, that parental blood and genetic material, together with fetal blood and/or DNA, is useful in medical identification and research. For example,

- 4 -

the fetal and parental blood and genetic material may be used to determine genetic sources or propensities to certain diseases and disabilities.

The difficulties in long term storage and retrieval of stored blood and DNA, mentioned hereinabove with reference to fetal blood and DNA, are exacerbated when blood and DNA samples from different individuals are involved.

Objects of the Invention

An object of the present invention is to provide a method for reducing, if not eliminating, errors which arise in the storage of multiple tissue samples or specimens from the same individual or from related individuals.

More particularly, an object of the present invention is to provide a method for reducing, if not eliminating, the error in storing multiple umbilical or fetal tissue samples or specimens from the same infant.

A related object of the present invention is to provide a method for reducing, if not eliminating, errors in storing umbilical or fetal tissue samples or specimens from an infant and tissue samples such as blood or DNA from the child's parents.

Yet another object of the present invention is to provide a method for providing multiple tissue samples of one individual or of related individuals for aiding in medical research, medical identification and therapeutic treatment which is less expensive and/or less invasive than other methods.

An additional, related object of the present invention is to provide an improved storage receptacle for use in practicing the method of the invention.

An associated object of the present invention is to provide a vial assembly for storing multiple specimens, especially related specimens.

Yet another object of the present invention is to provide such a vial assembly in which the number of stored specimens could be varied in accordance with circumstances.

A further, more particular, object of the present invention is to provide such a vial assembly in which each sample is isolated from other specimens.

Another particular object of the present invention

- 5 -

is to provide such a vial assembly in which automatic handling of the assembly is facilitated.

Yet another particular object of the present invention is to provide such a vial assembly in which removal of individual specimens is facilitated.

A more specific object of the present invention is to provide an improved vial assembly of the above-mentioned type with a support flange.

Another object of the present invention is to provide such a vial assembly which can be made by adapting a conventional cylindrical test-tube vial.

Another, more particular, object of the present invention is to provide such a vial assembly which is easy and inexpensive to make.

Summary of the Invention

A vial assembly comprises, in accordance with the present invention, a vial having a mouth aperture and defining a vial cavity, a cap removably attached to the vial to close the aperture and a partition member inside the cavity for dividing the cavity into multiple storage chambers accessible through the aperture. The cap is provided with an element or formation for facilitating removal of the cap from the vial.

In accordance with a first specific embodiment of the present invention, the partition member takes the form of an ampule which is smaller than the vial and therefore insertable into the vial cavity. More particularly, the vial cavity has a length dimension and a width dimension, while the ampule has an external length dimension smaller than the length dimension of the cavity and a width dimension smaller than the width dimension of the cavity. Pursuant to this embodiment of the invention, a plurality of subdividing ampules are inserted into the vial, each ampule having an effective external length dimension smaller than one-half of the effective length dimension of the vial cavity and an external width dimension smaller than the width dimension of the vial cavity.

In accordance with an alternative specific embodiment of the present invention, the partition member is inserted into the cavity to engage an inner surface of the vial.

Preferably, the partition member is removably

- 6 -

inserted into the cavity. Accordingly, the partition member is provided with a component such as a magnetizable element or a formation such as a tool-receiving key slot for facilitating removal of the partition member from the vial cavity.

The partition member is preferably disposed in the cavity in a transversely oriented plane, whereby the cavity is subdivided into a plurality of axially adjacent chambers.

The transversely oriented partition member may be provided in some applications with a longitudinally extending bore traversed in a substantially transversely oriented plane, i.e. in the plane of the partition element, by a flexible self-sealing membrane element. The membrane element enables insertion or removal of liquid material, by a hypodermic type syringe and needle, from the chamber defined in part by the partition member.

Pursuant to another feature of the present invention, the partition member is provided with a sealing element engaging the inner surface for forming a fluid tight seal therewith. Where the partition is located in a transverse plane of the vial and the vial defines a cylindrical receptacle cavity, the sealing element advantageously takes the form of an annular rib or lip.

Pursuant to a further feature of the present invention, the cap is provided with a longitudinally extending bore traversed in a substantially transversely oriented plane by a flexible self-sealing membrane element.

Pursuant to an additional feature of the present invention, the mouth aperture of the vial constitutes one of a pair of mouth apertures at opposite ends of the vial, while the cap constitutes one of two caps attached to the vial to close the apertures. With this feature of the invention, a vial containing multiple storage chambers may be accessed from opposite ends, thereby enhancing accessibility and ease of use.

A vial assembly pursuant to the second embodiment comprises, in accordance with a feature of the present invention, a vial having a mouth aperture and defining a receptacle cavity, a cap removably attached to the vial to close the aperture, and a partition member in the cavity for dividing the cavity into multiple storage chambers accessible through

- 7 -

the aperture. The partition member is disposed in the cavity in a transversely oriented plane and engages an inner surface of the vial. In addition, the partition member is provided with a circumferential seal engaging the inner surface of the vial for forming a fluid tight seal therewith.

As set forth hereinabove, the partition member is advantageously provided with a component such as a magnetizable element or a formation such as a tool-receiving key slot for facilitating removal of the partition member from the vial cavity.

Pursuant to a feature of the present invention already discussed above, the partition member is provided with a longitudinally extending bore traversed in a substantially transversely oriented plane by a flexible self-sealing membrane element which serves to facilitate access to a storage chamber through use of a hypodermic type syringe and needle. The cap may also be provided with a longitudinally extending bore traversed in a substantially transversely oriented plane by a flexible self-sealing membrane element.

It is contemplated that, in most cases, the vial cavity will be cylindrical, the circumferential seal taking the more specific form of an annular rib.

A device for dividing a receptacle cavity of a vial into multiple storage chambers accessible through a mouth aperture of the vial comprises, in accordance with the present invention, a body member and a seal on the body member engageable with an inner surface of the vial for forming a fluid tight seal therewith. Preferably, but not necessarily, the body member is provided with a component such as a magnetizable element or a formation such as a tool-receiving key slot for facilitating removal of the partition member from the vial cavity.

The body member generally has a shape corresponding to a transverse cross-section of the cavity and may be provided with a longitudinally extending bore traversed in a substantially transversely oriented plane by a flexible self-sealing membrane element.

A vial in accordance with the present invention comprises a perimetrically extending sidewall, a pair of end walls attached to the sidewall at opposite ends thereof, at

- 8 -

least one partition inside the sidewall and attached thereto intermediate the end walls for forming a multiplicity of storage chambers aligned with each other in a longitudinal direction defined by the sidewall, and access elements in at least one of the sidewall and the end walls for enabling access to each of the storage chambers.

One or both of the end walls may be formed by end caps with attachment elements for removably fastening the end caps to the sidewall. In that case, the access to one or more of the storage chambers is provided through the one or two end caps. Alternatively, access may be provided via a flexible self-sealing membrane element in the end cap.

Pursuant to another feature of the present invention, the partition takes the form of a removable insert or a permanent, essentially transversely extending wall section integral with the sidewall.

Pursuant to a further feature of the present invention, the access element takes the form of a flexible self-sealing membrane element in the insert. Alternatively, or additionally, the access element takes the form of a flexible self-sealing membrane element in one of the end walls and the sidewall. If such a flexible membrane is provided in the sidewall, it is advantageous for mounting purposes of the sidewall is provided with a thickened wall section in turn provided with an opening traversed by the membrane element.

A vial assembly comprises, in accordance with a particular embodiment of the present invention, a receptacle or vial having an opening, an outer surface and an outer transverse dimension defined by the outer surface and further comprises a cap member removably attached to the receptacle at the opening for covering the opening. A sealing member is attached to the receptacle or the cap member to form a seal between the receptacle and the cap member. The sealing member has an outer dimension greater than the outer transverse dimension of the receptacle so that the sealing member projects beyond the outer surface of the receptacle and forms a support for the vial assembly.

More specifically, the receptacle or vial takes a cylindrical form, and the receptacle and the cap member are providing with interlocking screw type threads defining

- 9 -

respective grooves. The sealing member takes the form of a ring seated in one of the grooves. Preferably, the cap member is provided with an external screw type thread and the receptacle is provided with an internal screw type thread. The sealing ring is then mounted to the cap member in a helical groove thereon.

Pursuant to another feature of the invention, the cap member is provided with a longitudinally extending bore traversed a substantially transversely oriented plane by a flexible self-sealing membrane element.

Pursuant to a further feature of the invention, the receptacle defines a cavity, and the vial assembly further comprises dividers inside the receptacle for dividing the cavity into multiple storage chambers accessible through the opening.

Preferably, the dividers include at least one partition member inserted into the cavity and engaging an inner surface of the receptacle. The partition member is disposed in the cavity in a transversely oriented plane and may be provided with a longitudinally extending bore traversed in a substantially transversely oriented plane by a flexible self-sealing membrane element. In addition, the partition member is provided with a sealing component engaging the inner surface for forming a fluid tight seal therewith.

As an alternative to the partition member, the divider or dividers may take the form of an ampule having an external length dimension smaller than the length dimension of the cavity defined by the receptacle. The ampule has a width dimension smaller than the width dimension of the cavity.

A vial assembly in accordance with the present invention is easy to make or assemble. A sealing ring performs a dual function of sealing and support.

A method for use in preparing a biological sample comprises, in accordance with the present invention, the steps of (a) upon the birth of an individual, obtaining at least a portion of a placenta and an associated umbilical cord which extended from the individual to the placenta, (b) extracting a first tissue sample and a second tissue sample from the portion of the placenta and umbilical cord, (c) providing a storage receptacle having at least two chambers, (d) deposit-

- 10 -

ing the extracted first tissue sample in one of the chambers and the extracted second tissue sample in another of the chambers, and (e) storing the receptacle.

Pursuant to another feature of the present invention, the first tissue sample is fetal blood fluid and the method further comprises the step of adding an anticoagulant to the fetal blood fluid. In addition, the second tissue sample is advantageously DNA for many applications. The DNA may be extracted, for example, from T-cells in the fetal blood or from vascular cells in the umbilical cord.

In accordance with another feature of the present invention, identification information is recorded as to the individual from which the fetal tissue samples were obtained. This identification information is carried advantageously on an identification tag applied directly to the storage receptacle. To that end, the identification tag may include a bar code encoding the identification information.

Preferably, the receptacle and its multiple tissue contents are stored in a cryogenic storage unit.

A method in accordance with the present invention drastically reduces, if not eliminates, the potential for error in retrieval of tissue samples for a single individual. DNA and blood for an individual will always be stored together, thus eliminating the possibility that samples will end up at different storage locations.

A related method for use in preparing biological samples comprises, in accordance with a further embodiment the present invention, the steps of (a) upon the birth of an individual, obtaining at least a portion of a placenta and an associated umbilical cord which extended from the individual to the placenta, (b) extracting a first biological specimen from the portion of the placenta and umbilical cord and (c) extracting a second biological specimen from a parent of the individual. The extracted first biological specimen is deposited in one chamber of a storage receptacle having a plurality of storage chambers, while the extracted second biological specimen is deposited in another of the chambers. The receptacle is then subjected to storage.

Pursuant to another feature of the present invention, the first biological specimen is fetal blood fluid and

- 11 -

the method further comprises the step of adding an anticoagulant to the fetal blood fluid. The second biological specimen may likewise take the form of blood fluid from the parent. Of course, an anticoagulant and possibly a cryopreservative are added the blood fluid samples prior to cryogenic storage.

The biological specimens may alternatively take the form of extracted and isolated DNA. An additional specimen may also be stored from the child and or the parent in the same receptacle. For example, a single storage receptacle in accordance with the invention will advantageously hold a fetal blood sample and/or a DNA specimen from the child and a blood sample and/or a DNA specimen from one or both parents.

The DNA of the child may be extracted, for example, from T-cells in the fetal blood or from vascular cells in the umbilical cord. The DNA of the parent may be extracted from T-cells in the blood, from other nucleated cells, or from sperm.

In accordance with another feature of the present invention, identification information is recorded as to the individual from which the fetal biological specimens were obtained. This identification information is carried advantageously on an identification tag applied directly to the storage receptacle. To that end, the identification tag may include a bar code encoding the identification information.

Preferably, the receptacle and its multiple tissue contents are stored in a cryogenic storage unit.

According to a broader conceptualization of the present invention, a method for use in preparing biological samples comprises the steps of (a) extracting a first biological specimen from a tissue sample from a first individual, (b) extracting a second biological specimen from a tissue sample of a second individual related to the first individual, (c) depositing the extracted first biological specimen in a chamber of a storage receptacle having at least two chambers, (d) depositing the extracted second biological specimen in another of the chambers, and (e) storing the receptacle.

Another vial assembly in accordance with the present invention comprises a plurality of modular storage units each

- 12 -

including a body portion defining a storage chamber, a first connector on one side and a second connector on an opposite side. The first connector of each modular storage unit is removably couplable to the second connector of each of the other storage units. Accordingly, each storage unit is coupled via a respective first or second connector to at least one other storage unit at a respective second or first connector.

Pursuant to a feature of the present invention, the first connector and the second connector take the form of an internally screw-threaded portion and an externally screw-threaded portion, respectively.

In accordance with another feature of the present invention, a cap is connected to a terminal one of the storage units, the cap being provided with a magnetic element. The cap is provided with a screw thread for enabling a temporary attachment of the cap to the terminal storage unit.

A method in accordance with the present invention reduces, if not eliminates, the potential for error in retrieval of biological specimens for a single individual (the child). In addition, the method enables reliable and accurate identification of parents by storing parental blood and/or DNA in conjunction with blood and/or DNA of a child. The parental samples are useful, for example, in subsequent attempts to identify and trace genetic diseases or abnormalities, particularly where the parent dies or otherwise becomes unavailable.

Pursuant to the present invention, DNA and/or blood from a child and one or more parents will always be stored together, thus eliminating the possibility that samples will end up at different storage locations.

Brief Description of the Drawing

Fig. 1 is a longitudinal cross-sectional view of a vial assembly in accordance with the present invention.

Fig. 2 is a longitudinal cross-sectional view of another vial assembly in accordance with the present invention.

Fig. 3 is a transverse cross-sectional view taken along line III-III in Fig. 2.

Fig. 4 is a longitudinal cross-sectional view of another vial assembly in accordance with the present inven-

tion.

Fig. 5 is a transverse cross-sectional view taken along line V-V in Fig. 4.

Fig. 6 is a longitudinal cross-sectional view of yet another vial assembly in accordance with the present invention.

Fig. 7 is a transverse cross-sectional view taken along line VII-VII in Fig. 6.

Fig. 8 is a cross-sectional view, on an enlarged scale, of a cap member shown in Fig. 1.

Fig. 9 is a top view of an ampule or vial cluster.

Fig. 10 is a side elevational view of the ampule cluster of Fig. 9.

Fig. 11 is a top view of another ampule cluster.

Fig. 12 is a top view of multiple ampule, for use in accordance with the present invention.

Fig. 13 is a side elevational view of the multiple ampule of Fig. 12.

Fig. 14 is a top view of another multiple ampule, for use in accordance with the present invention.

Fig. 15 is a side elevational view of another compartmentalized vial assembly for use in accordance with the present invention.

Fig. 16 is a schematic perspective view of yet another compartmentalized vial assembly for use in accordance with the present invention.

Fig. 17 is a top view of a modular storage unit from the compartmentalized vial assembly of Fig. 16.

Fig. 18 is a top view of a modular storage unit of another compartmentalized or multiple chamber vial assembly for use in accordance with the present invention.

Fig. 19 is a schematic perspective view of an additional compartmentalized vial assembly for use in accordance with the present invention.

Fig. 20 is a schematic perspective view of yet a further compartmentalized vial assembly for use in accordance with the present invention.

Fig. 21 is a bottom view of a cap or terminal connector member of the vial assembly of Fig. 20.

Fig. 22 is a perspective view of a modular storage

- 14 -

unit from the compartmentalized vial assembly of Fig. 20.

Fig. 23 is a partial cross-sectional view showing a modular storage section and a cap or connector member similar to that illustrated in Figs. 20 and 21.

Fig. 24 is a side elevational view of a modular storage section similar to storage sections of the compartmentalized vial assembly of Fig. 15.

Fig. 25 is a top view of an additional vial assembly for use in accordance with the present invention.

Fig. 26 is a top view of yet another vial assembly for use in accordance with the present invention.

Fig. 275 is a top view of yet a further vial assembly for use in accordance with the present invention.

Detailed Description

An umbilical cord and/or placenta is obtained upon the birth of an infant and blood is extracted from the cord and/or placenta, for example, by an aspiration procedure using a hypodermic needle. The aspiration of the fetal blood may be accomplished manually or automatically, for example, by using an apparatus disclosed in International Patent Application No. PCT/US91/00516 or U.S. Patent Application Serial No. 537,418 filed June 13, 1990.

An anticoagulant is added to the extracted blood sample. Preferably, the anticoagulant is added to the blood sample immediately upon extraction thereof. Alternatively, the anticoagulant may be injected into the vein and arteries of the umbilical cord and/or into the placenta prior to the extraction of the blood. The injection may be implemented manually or automatically as disclosed in International Patent Application No. PCT/US91/06109 filed August 27, 1991. In that case, the umbilical cord and/or placenta may be conveyed to another location for automatic removal of the fetal blood.

The blood may be removed from the placenta and/or umbilical cord automatically by techniques other than aspiration, as disclosed in International Patent Application No. PCT/US91/06109 filed August 27, 1991.

Alternatively or additionally, another biological specimen pertaining to the newly born infant, such as a DNA sample, may also be obtained from the umbilical cord or placenta. Genetic material is extracted by known techniques

- 15 -

from T-cells in the blood or from vascular cells in the arteries or vein of the cord. The genetic material is then processed or treated by known techniques to derive a sample of DNA which can be subjected to long term storage.

Upon the extraction of the fetal blood and/or the isolation of the DNA, one or both samples are then deposited in a storage receptacle. If both blood and DNA are used, the samples are deposited in different chambers of the same storage receptacle. In addition, a blood sample and/or a DNA specimen is obtained from one or both parents and is placed in a respective chamber of the same receptacle. Thus, a single storage receptacle may contain, in separate chambers, fetal blood, fetal DNA, blood from one parent, DNA from that parent, blood from the other parent, and DNA from that other parent. The storage receptacle advantageously takes the form of a vial or ampule described hereinafter with references to the drawing.

The storage of biological specimens from both the infant and one or both parents in the same storage vial at least reduces the possibility of error in retrieving the specimens. Moreover, reliable and accurate identification of the parents of a child is obtainable upon storing parental blood and/or DNA together with blood and/or DNA of the child. The parental samples are useful, for example, in subsequent medical research attempts to identify and trace genetic diseases or abnormalities, particularly where the parent dies or otherwise becomes unavailable. However, such research may be performed as a matter of course upon the birth of an individual. Inasmuch as some delay will inevitably occur prior to the testing and analysis of the specimens, the specimens are advantageously subjected to long-term cryogenic storage.

As illustrated in Fig. 1, a vial assembly with multiple sample storage capacity comprises a cup- or test-tube-shaped outer vial or receptacle 10 and a pair of inner ampules or storage containers 12 and 14. Each inner ampule 12 and 14 includes a test-tube-type receptacle 16 having a closed end 18 and an opening 20 at an opposite end. In addition, each inner ampule 12 and 14 includes a cap or cover member 22 provided with a sealing ring 23 and on one end with an external screw thread 24 for cooperating with an internal screw thread (not

- 16 -

designated) on the ampule receptacle 16 to seal the respective ampule 12 or 14.

Each ampule 12 and 14 has an effective external length dimension l_a which is less than half of an effective length l_c of an elongate cavity 26 defined by vial 10. In addition, each ampule 12 and 14 has an external width dimension w_a which is less than a width w_c of cavity 26. Because of the relative sizes, a plurality of ampules 12 and 14 may be inserted into cavity 26 prior to the sealing of vial 10 with a cap 28.

Cap 28 is attached to one end of vial or receptacle 10 by means of an external screw thread 30 which cooperates with an internal screw thread (not designated) on vial 10 to seal the vial. In addition, cap 28 is provided with a magnetizable or magnetic element or insert 32 for facilitating the automatic handling of vial 10, for example, conveyance of vial 10 from one location to another, and insertion and removal of the vial from a cryogenic storage unit such as that described in U.S. Patent No. 4,969,336.

Cap 28 has a resilient ring 33 for enhancing the seal between vial 10 and cap 28. As described in detail hereinafter with reference to Fig. 8, ring 33 performs a support function as well as a sealing function.

Each ampule 12 and 14 in the vial assembly of Fig. 1 contains one of the samples taken from the umbilical cord or placenta of a newly born infant. More specifically, one ampule 12 or 14 holds a blood sample, while the other ampule 14 or 12 holds a DNA specimen. Because ampules 12 and 14 are stored in the same vial 10, the DNA always accompanies the blood and vice versa. The danger of separation of the two samples during long term storage is greatly reduced.

Alternatively, each ampule 12 and 14 in the vial assembly of Fig. 1 contains a sample taken from the umbilical cord or placenta of a newly born infant or a sample taken from one of the infant's parents. More specifically, one ampule 12 or 14 holds a blood or DNA sample from the infant, while the other ampule 14 or 12 holds a blood or DNA specimen from the parent. Because ampules 12 and 14 are stored in the same vial 10, the DNA or blood from the parent always accompanies the blood or DNA from the child. The danger of separation of the

- 17 -

two samples during long term storage is greatly reduced.

Of course, the vial assembly of Fig. 1 may contain more than two ampules 12 and 14, for storing multiple biological specimens or tissue samples from both the infant and one or more parents. A single vial assembly may contain, in separate ampules, fetal blood, fetal DNA, blood from one parent, DNA from that parent, blood from the other parent, and DNA from that other parent.

As illustrated in Fig. 2, another vial assembly comprises a cup- or test-tube-shaped outer vial or receptacle 34 provided at opposite ends with mouth apertures or openings 36 and 38. Screwed to vial 34 at apertures 36 and 38 to close those openings are two caps 40 and 42. Like cap 28 in the embodiment of Fig. 1, cap 40 is provided on one end with an external screw thread 44 for cooperating with an internal screw thread (not designated) on vial 34 to seal the vial. In addition, cap 40 is provided with a magnetizable or magnetic element or insert 46 for facilitating the automatic handling, transport and opening and closure of vial 34. Like vial 10, vial 34 may be used for the low-temperature storage of multiple related tissue samples in a cryogenic storage unit such as that described in U.S. Patent No. 4,969,336.

Cap 40 has a resilient ring 48 for enhancing the seal between vial 34 and cap 40. As described in detail hereinafter with reference to Fig. 8, ring 48 performs a support function as well as a sealing function.

Cap 42 is also provided at one end with an external screw thread 50 for cooperating with an internal screw thread (not referenced) on vial 34 to lock cap 42 to the vial in a fluid-tight manner. The seal between cap 42 and vial 34 is enhanced by a resilient ring 52. Cap 42 further includes an annular magnetic element 54 for facilitating handling, transport and opening and closure of vial 34 at the end of aperture 38. A hole 56 in annular magnetic element 54 is axially aligned with a longitudinally extending bore 58 in cap 42. Bore 58 is closed by a transversely oriented resilient self-sealing membrane 60. Membrane 60 enables access to a storage chamber 62 in vial 34 through use of a hypodermic type syringe and needle (not illustrated). Such a syringe and needle may be used to insert or remove blood samples or even

- 18 -

DNA specimens from storage chamber 62.

Storage chamber 62 is defined at one end by cap 42 and at an opposite end by a partition member 64 inserted into vial 34. Partition member 64 has an annular body portion 66 which is provided at one side with an annular sealing lip or rib 68 and which defines a central longitudinally oriented bore 70. Bore 70 is traversed by a transversely oriented resilient self-sealing membrane 72 which enables access to a second storage chamber 74 in vial 34 through use of a hypodermic type syringe and needle (not illustrated). Such a syringe and needle may be used to insert or remove samples from storage chamber 74 provided that outer storage chamber 62 is empty (to prevent the cross-contamination which would otherwise occur if outer chamber 62 contained a biological sample).

Storage chamber 74 is defined at one end by a partition member or insert 64 and at an opposite end by a removable partition member 76. Partition member 76 includes a cylindrical body portion 78 provided on an outer surface with two circumferential or annular beads or ribs 80 and a longitudinally extending circumferential lip or rib 82. Ribs 80 and 82 engage an inner surface 84 of vial 34 to provide a fluid-tight seal therewith.

Partition member 76 is further provided on body portion 78 with an annular inwardly extending flange 84 in which an annular magnetic element 86 is embedded. Magnetic element 86 is magnetizable by an electromagnetic tool (not depicted) for facilitating a removal of partition member or insert 76 from vial 34. Flange 84 defines a central longitudinally extending bore 88 which is traversed in a transverse plane by a flexible self-sealing membrane 90 having the same function as described above with reference to membranes 60 and 72.

Partition member 76, together with inner surface 84 of vial 34 and another removable partition member or insert 92, defines another storage chamber 94 in vial 34. Storage chambers 62, 74 and 94 are axially aligned with a fourth storage chamber 95 and together with partition members 64, 76 and 92 are coextensive with the cavity defined by vial 34.

Partition member 92, like partition member 76, comprises a cylindrical body portion 96 provided on an outer sur-

- 19 -

face with two circumferential or annular beads or ribs 98 and a longitudinally extending circumferential lip or rib 100. Ribs 98 and 100 engage inner vial surface 84 to provide a fluid-tight seal therewith.

Partition member 92 is further provided on body portion 96 with an annular inwardly extending flange 102 which defines a central longitudinally extending bore 104 which is traversed in a transverse plane by a flexible self-sealing membrane 106 having the same function as described above with reference to membranes 60 and 72.

As shown in Figs. 2 and 3, body portion 96 of partition member 92 has two pairs of radially inwardly extending tongues 108 and 110. Tongues 108 and 110 define respective key slots 112 and 114 for receiving a removal tool (not shown).

Clearly, the partition members 64, 76 and 92 may be used in virtually any number, combination or permutation. The end caps on vial 34 may be identical, for example, like end cap 40 or 42. Or one end of vial 34 may be closed as in vial 10.

In another vial assembly illustrated in Figs. 4 and 5, a vial or receptacle body 116 is provided with a plurality of transversely extending planar partitions or walls 118 and 120 integral with a longitudinally extending sidewall 122 of the vial 116. Partitions 118 and 120, together with sidewall 122, a closed end portion 124 and a cap member 126, define three chambers 128, 130 and 132 for receiving and storing respective specimens such as fetal or umbilical blood and/or DNA, and parental blood and genetic material.

Insofar as upper chamber 128 is closed by a detachable end cap member 126, that chamber can be used to store non-fluidic samples such as parts of an organ or other biological tissue. End cap member 126 includes on a body portion 134 a plurality of perimetricaly or circumferentially extending ribs 136 which serve a sealing function and also serve to lock cap member 126 to vial or receptacle body 116 in a friction fit. An uppermost rib 138 cooperates with a transverse plate 140 of the end cap member 126 define an annular groove (not designated) which receives a ring 160, as described below. End cap member 126 carries a magnetic or

- 20 -

magnetizable element 144.

Vial 116 is provided along one side with a longitudinally extending thickened wall section 146 forming an elongate planar land area on an inner side of the vial. Thickened wall section 146 is provided with three apertures or bores 148, 150 and 152 each opening into a respective storage chamber 128, 130 and 132 and each traversed or covered by a flexible self-sealing membrane 154, 156 and 158. The function of membranes 154, 156 and 158 is to provide access to the storage chambers, with an automatic closure capability, as described above. Membranes 154, 156 and 158 are planar elements.

Vial 116 is provided with ring 160 seated in a snap-lock fit in the groove defined by rib 138 and plate 140. Ring 160 forms a flange extending radially outwardly to enable support of the vial assembly in an aperture of a support bar or shelf.

It is to be noted that the multiple storage function of the vial assembly of Figs. 4 and 5 may still be implemented if flange ring 160 is omitted and both ends of vial 116 are closed like end portion 124. In that case, one or both ends are advantageously provided with flattened transverse walls to enable vial 116 to stand on a planar horizontal surface. Such a flattened transverse end wall is shown in Fig. 6 at 162. That end wall is provided with a magnetic handling and transport element 163.

As depicted in Figs. 6 and 7, another vial assembly comprises a vial or receptacle body 164 provided with a transversely extending planar partition or wall 166 and another essentially transversely extending partition 168 including a pair of oppositely inclined partition sections 170 and 172. Partitions 166 and 168, together with a cylindrical sidewall 174, transverse end wall 162 and an opposite transverse end wall 176, define three storage chambers 178, 180 and 182.

In a region about end wall 176, vial body 164 is provided with an annular groove 183 in which a ring 184 is seated in a snap-lock fit to form an outwardly extending support flange 184. Vial body 164 also has an annular magnetic element 186 is provided with a bore 188 communicating with a hole 190 in end wall 176. A flexible self-sealing membrane

- 21 -

192 covers hole 190.

Partition sections 170 and 172 define a well 194 for facilitating a withdrawal through membrane 192 of fluid stored in chamber 178. Similar access via a hypodermic syringe and needle (not shown) to chambers 180 and 182 is attained through a pair of arcuate self-sealing membranes 196 and 198 disposed in openings 200 and 202 in sidewall 174. Membranes 196 and 198 may be formed, for example, as a web of flexible polymeric material in which is embedded a gridwork of form-maintaining support filaments (not illustrated) made of metal or a harder polymeric material. Alternatively, membranes 196 and 198 may each be formed as a continuous or unitary flexible polymeric material which forms a planar, rather than arcuate, fluid-impermeable pierceable barrier across the respective opening 200 and 202.

The chamber access structure of the embodiments of Figs. 4-7, i.e., through membranes 154, 156, 158 and 192, 196, 198 in the sidewalls of the respective vials, is considered advantageous insofar as there is little or no possibility of cross-contamination between samples stored in the different chambers.

The vial assemblies of Figs. 4-7 are each circular in transverse cross-section. However, other cross-sections for those vial assemblies, as well as other vial assemblies disclosed herein, can be used. In addition, it is to be understood that different combinations and permutations of the partitions in each vial assembly and among vial assemblies can be selected for different applications. For example, a vial may be provided with a permanent partition as shown in the embodiments of Figs. 4-7, as well as a removable partition or inner ampule as in the embodiments of Figs. 2 and 1.

As illustrated in Fig. 8, cap member 33 is formed with external screw type thread 30 which interlockingly mates with an internal screw type thread (not separately illustrated) on the inner surface of cavity 26 (Fig. 1). Ring 33 is sealingly seated in a circular end portion of a helical groove 204 defined by thread 30. Because ring 33 has an outer diameter d_1 substantially larger than an outer diameter or transverse dimension d_2 of vial 10, ring 33 projects substantially beyond an outer cylindrical surface 206 of cap member

- 22 -

28 and an outer cylindrical surface 208 (Fig. 1) of vial 10, thereby forming an annular flange for supporting the vial assembly of Fig. 1 in an aperture of a bar or other support as disclosed in Patent No. 4,969,336.

Cap member 28 with ring 33 may be used to close conventional single-cavity or single-chamber vials which have no integral support flange. Ring 33 is especially cost effective in providing both a sealing function and a support function. Preferably, ring 33 is made of a semi-rigid resilient material such as a silicone or polymeric material.

The above description with reference to Fig. 8 also applies to cap member 40 and sealing ring 48 (Fig. 2).

One skilled in the art will readily understand that some of the multiple chamber vial assemblies disclosed herein are more suitable for storing biological specimens from different individuals, insofar as those vial assemblies prevent or inhibit cross-contamination between the different specimens. The vial assemblies of Figs. 1 and 4-7 fall into this category. In contrast, the vial assembly of Figs. 2 and 3 may be unsuitable for certain applications insofar as tissue, cells or molecules from one chamber 74, 94 or 95 may become mixed with tissue, cells or molecules from one or more other chambers 62, 74 and 94 upon an attempt to remove materials from the one chamber 74, 94, or 95. This mixing, however, can be avoided by properly sequencing the extraction of materials from chambers 62, 74, 94 and 95.

As depicted in Figs. 9 and 10, a cluster ampule assembly 302 includes a star-shaped holder 304 with a central node element 305 and five radiating arms or spokes 306 each provided at an outer end with a ring 308. Seatable in each ring 308 is a respective ampule 310 having an annular flange 312 at an upper end and a magnetic cap 314. Node element 305 is provided with a carrier ring 316 for enabling removal of the entire ampule cluster through a doorway in a cryogenic storage unit such as that illustrated and described in Patent No. 4,969,336. In addition, holder 304 is provided on the underside of node element 305 with a lug 318 for insertion into a hole or recess (not illustrated) in a support bar of the cryogenic storage unit (see Fig. 5 of Patent No. 4,969,336).

- 23 -

Fig. 11 shows another cluster ampule assembly 322 includes a holder 324 with a central node element 325 and a three radiating arms or spokes 326 each provided at an outer end with a ring 328. Node element 325 has a carrier ring 336 on an upper side for enabling insertion and removal of the entire ampule cluster through a doorway in a cryogenic storage unit.

In use, five samples of the same specimen may be placed in the five ampules 310, which are then stored in the cluster assembly 302 in a cryogenic storage apparatus. If two samples are requested, two ampules 310 are removed and the other three are transferred to a three-ring holder 324 and then returned to the cryogenic storage apparatus. Of course, four-ring and two-ring holders may also be provided.

Alternatively, a multiple-chamber vial assembly such as those illustrated in Figs. 1-8 may be used to store different biological specimens (e.g., fetal blood and DNA) from the same individual. Several such vial assemblies holding multiple biological specimens from several related individuals such as twins or triplets may be placed in rings 308 of cluster ampule assembly 302 or rings 328 of cluster ampule assembly 322. If the vial assemblies take the form of the vial assembly of Fig. 1 or 2, then the vial are supported on rings 308 or 328 via sealing rings 33 or 48, respectively.

Figs. 12 and 13 depict a twin storage vial comprising a pair of cup- or test-tube-shaped ampules or receptacles 402 and 404 rigidly fixed to one another via a bracket or arm 406. Integral with arm 406 is a cylindrical lug 408 for insertion into an aperture of a bar or other support as disclosed in Patent No. 4,969,336. Each ampule or receptacle 402 and 404 includes a respective body portion 410, a cap 412 and a ring-shaped gasket 414 for sealing the closure upon attachment of cap 412 to body portion 410. Cap 412 may also be provided with a magnetizable insert 416, as discussed hereinabove with reference to Figs. 1 and 2.

Ampules or receptacles 402 and 404 may each take the form of a multiple chamber vial assembly as described above. Thus, each ampule or receptacle 402 and 404 may be used for holding several different biological specimens (e.g., fetal blood and DNA) from the same individual. And different

- 24 -

ampules or receptacles 402 may be reserved for the same or different individuals.

Fig. 14 shows a triplet storage vial assembly comprising three cup- or test-tube-shaped ampules or receptacles 418, 420 and 422 rigidly fixed to one another via brackets or arms 424, 426 and 428.

As illustrated in Fig. 15, a compartmentalized or multichamber vial assembly comprises a plurality of modular storage units 430 each having a body portion defining a storage compartment or chamber 432. At one end, each storage unit 430 is provided with an internally screw-threaded female connector portion 434. At an opposite end, each modular storage unit 430 is provided with an externally screw-threaded male connector portion 436. The male connector portion 436 of each storage unit 430 is couplable with a female connector portion 434 of an adjacent storage unit to form a vial having at least two storage chambers.

An uppermost terminal modular storage unit 438 carries a cap member 440 which is provided with a magnetic or magnetizable element 442 as described hereinabove with reference, for example, to Fig. 2. Cap member 440 has an externally screw-threaded male connector portion 444 which connects with an internally screw-threaded female connector portion 446 at the end of terminal storage unit 438.

A lowermost terminal modular storage unit 448 may be formed with a rounded end 450 or, alternatively, may be formed with a male connector portion 436 as in the other storage units 430.

Each storage unit 430, 438, 448 is provided in a sidewall with an opening 452 covered with a flexible self-sealing membrane 454. Alternatively, storage units 430, 438, 448 may be provided at the base 456 of female connector portion 446 with a membrane-covered opening.

It is to be noted that storage units 430 may be provided in a plurality of different lengths, connectable in different combinations according to the requirements of different situations.

Figs. 16 and 17 show another compartmentalized vial assembly including two or more modular vertical storage sections 458 each having a cross-section in the form of a pie

- 25 -

slice. Each pie-slice storage section 458 has a cylindrical wall 460 and pair of mutually orthogonal planar walls 462 and 464. One planar wall 462 is formed with a T-shaped slot 466, while the other planar wall 464 is provided with a T-shaped rib 468. Rib 468 on one modular storage section 458 is insertable into the slot 466 of an adjacent storage section 458, whereby a disassemblable cylindrical vial assembly (Fig. 16) may be constructed.

As further depicted in Fig. 17, each storage section 458 is provided in an upper wall 470 with a magnetic or magnetizable element 471 for facilitating automatic conveyance as described above. In addition, each storage section 458 is formed with a flexible sealing membrane 472 which may be pierced by a hypodermic needle for deposition and extraction of a sample, as described hereinabove. In the event that the storage sections 458 are themselves subdivided into longitudinally aligned subchambers (not shown) each subchamber is provided with a respective flexible sealing membrane 472.

Fig. 18 illustrates an alternative embodiment of a modular vertical storage section 474 of a compartmentalized vial. Storage section 474 is provided in a first planar wall 476 with a permanent magnetic strip or plate 478. A second planar wall 480 extending at an angle with respect to wall 476 is provided with a magnetizable metal strip or plate 482. Metal plate 482 has approximately the same vertical position as magnetic plate 478, whereby the magnetic plate 482 of one modular storage section 474 is juxtaposed to the metal plate 482 of an adjacent modular storage section and forms a releasable magnetic lock to secure the two storage sections to one another. As described hereinabove with reference to Figs. 16 and 17, the modular storage section 474 of Fig. 18 is provided with one or more flexible sealing membranes 484.

As depicted in Fig. 19, another vial assembly for use in practicing the above-described method of specimen storage in preparation for eventual research, medical identification or therapeutic use comprises two or more modular vertical storage sections 486 each having a cross-section in the form of a pie slice. Each modular storage section 486 is formed with one or more specimen storage chambers (not indicated) to which access is attained via respective membrane-

- 26 -

covered openings 488. Modular storage sections 486 are formed with at least one external, circumferentially extending groove segment 490 which aligns with the grooves on the other storage sections to form a circular groove 492 for receiving a clamping ring 494. Ring 494 serves to maintain modular storage sections 486 in a cylindrical configuration with respect to each other.

Fig. 20 shows a further compartmentalized vial assembly for use in a specimen storage or preparation method described herein. A plurality of modular storage sections 496 having pie-slice-shaped cross-sections are attached to each other in a cylindrical configuration via a pair of end caps or connector elements 498 and 500. Each modular storage section 496 is formed with one or more specimen storage chambers (not indicated) to which access is attained via respective membrane-covered openings 502.

As illustrated in Fig. 21, each end cap 498 and 500 is preferably provided on an inner side with a plurality of intersecting partitions 504 serving to form a plurality of pie-slice-shaped recesses 506 for receiving ends of respective modular storage sections 496. The ends of the modular storage sections may be inserted into recesses 506 in a force lock fit. Alternatively, or additionally, cap member 498 and 500 may be provided on a cylindrical inner surface 508 with resilient radially inwardly extending projections 510 which are removably inserted into respective recesses 512 on outer cylindrical surfaces 514 of modular storage sections 496, as shown in Fig. 22. Projections 510 and recesses 512 thus cooperate with one another to provide a snap lock between modular storage sections 496 and end caps 498 and 500.

As yet another alternative locking mechanism, end caps 498 and 500 may be provided with a plurality of magnetic or magnetizable elements 516 for magnetically locking modular storage sections 496 to the end caps. Of course, modular storage sections 496 are provided at their ends with cooperating permanent magnets or magnetic metal elements (not shown).

End cap 498 may be formed with an internally threaded cylindrical recess 518 for receiving an externally threaded cylindrical male member 520 on the cap member 500 of another vial assembly, whereby the compartmentalized vial

- 27 -

assembly of Fig. 20 is itself a modular unit in a larger receptacle assembly. Alternatively, cap member 498 may be provided with a magnetic element (not shown) for enabling magnetic conveyance of the assembly of Fig. 20.

End cap 498 is optionally formed with an annular sealing ring 522 which also acts as a support flange.

Fig. 23 depicts a modification of the coupling lock between an end cap 498 or 500 and a storage section 496 illustrated in Figs. 21 and 22. As shown in Fig. 23, an end cap 524 is formed with a recess 526 which receives a rib 528 on a modular storage section 530 in a snap lock coupling to releasably lock the storage section to the end cap. Other kinds of couplings between pie-slice-shaped storage sections may be used by one skilled in the art without departing from the invention.

As shown in Fig. 24, another modular storage section 532 comprises a body portion 534 provided with a plurality of transversely extending partitions 536 serving to define a plurality of storage chambers 538. Attached to body portion 534 is a cap member 540. Cap member 540 closes an end chamber 542 of storage section 532 and is provided with an internally threaded bore 544. At an end opposite cap 540 and bore 544, body portion 534 is formed with an externally threaded bolt element 546 insertable into a bore 544 of another storage section for connecting the storage sections to one another in the manner illustrated in Fig. 15.

In the modular storage section 532 of Fig. 24, cap member 540 is optionally provided with an annular sealing and support flange 548. In addition, each storage chamber 538, 542 is provided with an opening 550 covered with a flexible sealing membrane 552. Of course, the cap covered storage section 532 of Fig. 24 may come in different sizes with storage chambers varying in number from one up.

Fig. 25 shows a further compartmentalized vial assembly for use in a specimen storage or preparation method described herein. A plurality of modular storage sections 554 having trapezoidal cross-sections are attached in a substantially annular configuration to a substantially octagonal holder 556. Holder 556 is hollow and is provided on each of eight sides 558 with an outwardly projecting, longitudinally

- 28 -

extending rib 560. Each rib 560 is received, e.g., in a snap-lock fit, in a groove 562 in a respective modular storage section 554. As an alternative, one or more of the sides or walls 558 of holder 556 may have inwardly disposed grooves 563 for receiving mating ribs (not designated) on respective modular storage sections.

As illustrated in Fig. 26, a compartmentalized vial assembly for use in a specimen storage or preparation method described herein comprises a plurality of modular storage sections 564 having rectangular cross-sections. Storage sections 564 are connected to a rectangular holder 566 in a substantially annular configuration via mating grooves 568 and ribs 570. Grooves 568 and ribs 570 may be provided with enlarged end regions 572 to enhance the locking function.

As depicted in Fig. 27, a further compartmentalized vial assembly for use in a specimen storage or preparation method described herein comprises a plurality of modular storage sections 574 having pie-slice-shaped cross-sections. Each modular storage section 574 is provided in a pair of orthogonally oriented walls 576 with a pair of magnetic plates 578 which serve to removably attach the respective storage section 574 to a cross shaped holder 580 having four planar arms 582. Of course, holder 580 may be formed with more arms than four and pie-slice-shaped sections 574 may have an acute angle between its walls 576, instead of a right angle as indicated in Fig. 27.

As described hereinabove with reference to other vial assemblies, the modular storage sections 554, 564, and 574 of Figs. 25, 26, and 27 are provided with pierceable but liquid-impermeable membranes (not shown in Figs. 25, 26, and 27) which cover access openings in the modular storage sections.

Upon deposition of blood and/or DNA samples in respective chambers of the same vial or receptacle assembly, as discussed hereinabove, the entire storage assembly is preferably subjected to cryogenic temperatures to cryopreserve the stored samples. The freezing may be implemented by any known technique such as freeze drying. Moreover, many techniques are known for controlled rate freezing to optimize the viability of the cryopreserved samples.

- 29 -

In an additional series of steps, various constituents, for example, blood or endothelial vein cells, of an umbilical cord which are isolated from an umbilical cord sample at the birth of an infant are analyzed and typed according to known methods. For example, the blood type, the blood protein concentrations, the karyotype, the HLA and other factors are all determined and recorded. These umbilical cord parameters are included in the general statistical information pertaining to the personal history of the individual, including his or her name, parentage, birth date, weight, sex, etc., which is generally collected by a health care institution such as a hospital.

The same analyses and typing may be performed on the parental specimens. The resulting parameters may be recorded as part of the statistical information pertaining to the personal history of the infant.

At least some of this identification information pertaining to the newly born infant may be encoded and placed on an identification tag which is attached to the storage receptacle. The information is advantageously placed in a bar code form.

Upon the freezing of a fetal blood sample and an associated DNA sample in their multiple chamber storage receptacle, in accordance with the present invention, the receptacle is deposited in a cryogenic storage unit as described hereinabove. The identification information may also be entered into the memory banks of a computer associated with the cryogenic storage unit, as described in Patent No. 4,969,336.

Accordingly, blood from cryopreserved umbilical cord segments may be used, in accordance with the invention, in bone marrow reconstitution. More particularly stated, the stored umbilical cord or fetal blood includes hematopoietic stem and multipotential (CFU-GEMM), erythroid (BFU-E), and granulocyte-macrophage (CFU-GM) progenitor cells utilizable in hematopoietic reconstitution as an alternative to bone marrow transplantation. See, e.g., "Human umbilical cord blood as a Potential Source of Transplantable Hematopoietic Stem/Progenitor Cells" by Hal E. Broxmeyer et al., Proceedings, National Academy of Sciences, Vol. 86, pp. 3828-32

- 30 -

(1989). Broxmeyer et al. noted that umbilical cord blood contains numbers of CFU-GM cells well within the range of bone marrow CFU-GM cells that have been associated with successful autologous and major histocompatibility complex-matched allogenic bone marrow transplantation. The conclusion to be drawn from that study is that cells from human umbilical cord blood from a single individual are sufficient for autologous reconstitution and for major histocompatibility complex-matched allogenic hematopoietic reconstitution.

Although the invention has been described in terms of particular embodiments and applications, one of ordinary skill in the art, in light of this teaching, can generate additional embodiments and modifications without departing from the spirit of or exceeding the scope of the claimed invention. For example, blood and/or DNA samples from siblings such as fraternal or identical twins or triplets may be stored in the same compartmentalized vial assembly.

Accordingly, it is to be understood that the drawings and descriptions herein are proffered by way of example to facilitate comprehension of the invention and should not be construed to limit the scope thereof.

- 31 -

WHAT IS CLAIMED IS:

1. A vial assembly comprising:
a vial having a mouth aperture and defining a vial cavity;
a cap removably attached to said vial to close said aperture, said cap being provided with removal means for facilitating removal of said cap from said vial; and
means inside said cavity for dividing said cavity into multiple storage chambers accessible through said aperture.
2. The assembly recited in claim 1 wherein said means for dividing includes at least one partition member inserted into said cavity and engaging an inner surface of said vial.
3. The assembly recited in claim 2 wherein said partition member is removably inserted into said cavity.
4. The assembly recited in claim 3 wherein said partition member is provided with additional removal means for facilitating removal of said partition member from said cavity.
5. The assembly recited in claim 4 wherein said additional removal means includes a magnetizable element.
6. The assembly recited in claim 4 wherein said additional removal means includes a key slot for receiving a removal tool.
7. The assembly recited in claim 2 wherein said partition member is disposed in said cavity in a transversely oriented plane.
8. The assembly recited in claim 7 wherein said partition member is provided with a longitudinally extending bore traversed in a substantially transversely oriented plane by a flexible self-sealing membrane element.

- 32 -

9. The assembly recited in claim 2 wherein said partition member is provided with sealing means engaging said inner surface for forming a fluid tight seal therewith.

10. The assembly recited in claim 9 wherein said partition member is disposed in said cavity in a transversely oriented plane, said sealing means including at least one annular rib.

11. The assembly recited in claim 1 wherein said cap is provided with a longitudinally extending bore traversed in a substantially transversely oriented plane by a flexible self-sealing membrane element.

12. The assembly recited in claim 1 wherein said chambers are axially disposed relative to said vial.

13. The assembly recited in claim 1 wherein said cavity has a length dimension and a width dimension, said means for dividing including an ampule having an external length dimension smaller than the length dimension of said cavity and a width dimension smaller than the width dimension of said cavity.

14. The assembly recited in claim 13, further comprising an additional ampule having an external length dimension smaller than one-half of the length dimension of said cavity and an external width dimension smaller than the width dimension of said cavity.

15. The assembly recited in claim 1 wherein said mouth aperture constitutes one of a pair of mouth apertures at opposite ends of said vial, said cap constituting one of two caps attached to said vial to close said apertures.

16. A vial assembly comprising:
a vial having a mouth aperture and defining a receptacle cavity;
a cap removably attached to said vial to close said aperture; and

- 33 -

means in said cavity for dividing said cavity into multiple storage chambers accessible through said aperture, said means for dividing including at least one partition member disposed in said cavity in a transversely oriented plane and engaging an inner surface of said vial, said partition member being provided with sealing means engaging said inner surface for forming a fluid tight seal therewith.

17. The assembly recited in claim 16 wherein said partition member is provided with removal means for facilitating removal of said partition member from said cavity.

18. The assembly recited in claim 17 wherein said removal means includes a magnetizable element.

19. The assembly recited in claim 17 wherein said removal means includes a key slot for receiving a removal tool.

20. The assembly recited in claim 16 wherein said partition member is disposed in said cavity in a transversely oriented plane.

21. The assembly recited in claim 20 wherein said partition member is provided with a longitudinally extending bore traversed in a substantially transversely oriented plane by a flexible self-sealing membrane element.

22. The assembly recited in claim 20 wherein said sealing means includes at least one annular rib.

23. The assembly recited in claim 16 wherein said cap is provided with a longitudinally extending bore traversed in a substantially transversely oriented plane by a flexible self-sealing membrane element.

24. The assembly recited in claim 16 wherein said chambers are axially disposed relative to said vial.

25. A vial assembly comprising:

- 34 -

a vial having a mouth aperture and defining a vial cavity having a length dimension and a width dimension;

a cap removably attached to said vial to close said aperture;

an ampule having an external length dimension smaller than the length dimension of said cavity and an external width dimension smaller than the width dimension of said cavity, said ampule being inserted into said vial.

26. The assembly recited in claim 25 wherein said external length dimension is less than one-half of the length dimension of said cavity, further comprising an additional ampule having an external length dimension smaller than one-half of the length dimension of said cavity and an external width dimension smaller than the width dimension of said cavity.

27. A device for dividing a receptacle cavity of a vial into multiple storage chambers accessible through a mouth aperture of said vial:

a body member; and

sealing means on said body member engageable with an inner surface of said vial for forming a fluid tight seal therewith.

28. The assembly recited in claim 27 wherein said body member is provided with removal means for facilitating removal of said device from said cavity.

29. The assembly recited in claim 28 wherein said removal means includes a magnetizable element.

30. The assembly recited in claim 28 wherein said removal means includes a key slot for receiving a removal tool.

31. The assembly recited in claim 27 wherein said body member has a shape corresponding to a transverse cross-section of said cavity.

- 35 -

32. The assembly recited in claim 31 wherein said body member is provided with a longitudinally extending bore traversed in a substantially transversely oriented plane by a flexible self-sealing membrane element.

33. The assembly recited in claim 31 wherein said sealing means includes at least one annular rib.

34. A vial comprising:
a perimetrically extending sidewall;
closure means attached to said sidewall at opposite ends thereof for forming a pair of end walls;
partition means inside said sidewall and attached thereto intermediate said end walls for forming a multiplicity of storage chambers aligned with each other in a longitudinal direction defined by said sidewall; and
access means in at least one of said sidewall and said end walls for enabling access to each of said storage chambers.

35. The vial recited in claim 34 wherein said closure means includes at least one end cap with means for removably fastening said end cap to said sidewall at one end thereof.

36. The vial recited in claim 35 wherein said access means includes said end cap.

37. The vial recited in claim 35 wherein said access means includes a flexible self-sealing membrane element in said end cap.

38. The vial recited in claim 34 wherein said closure means is different at opposite ends of said sidewall.

39. The vial recited in claim 34 wherein said partition means includes a removable insert.

40. The vial recited in claim 39 wherein said access means includes a flexible self-sealing membrane element in

- 36 -

said insert.

41. The vial recited in claim 34 wherein said partition means includes a permanent, essentially transversely extending wall section integral with said sidewall.

42. The vial recited in claim 34 wherein said access means includes a flexible self-sealing membrane element in one of said closure means and said sidewall.

43. The vial recited in claim 42 wherein said sidewall is provided with a thickened wall section in turn provided with an opening traversed by said membrane element.

44. The vial recited in claim 42 wherein said sidewall is cylindrical and said membrane element is arcuate.

45. The vial recited in claim 34 wherein said closure means is provided with means for facilitating handling of the vial.

46. The vial recited in claim 45 wherein said means for facilitating includes a magnetic element.

47. A vial assembly comprising:

a receptacle having an opening, an outer surface and an outer transverse dimension defined by said outer surface;

a cap member removably attached to said receptacle at said opening for covering said opening; and

a sealing member attached to one of said receptacle and said cap member to form a seal between said receptacle and said cap member, said sealing member having an outer dimension greater than said outer transverse dimension so that said sealing member projects beyond said outer surface and forms a support for the vial assembly.

48. The vial assembly set forth in claim 47 wherein said receptacle has a pair of opposite ends, said opening being disposed at one of said ends.

- 37 -

49. The vial assembly set forth in claim 48 wherein said receptacle and said cap member are providing with interlocking threads defining respective grooves, said sealing member taking the form of a ring seated in one of said grooves.

50. The vial assembly set forth in claim 49 wherein the outer dimension of said sealing member is an outer diameter of said ring.

51. The vial assembly set forth in claim 49 wherein said receptacle has an internal screw type thread and said cap member has an external screw type thread mating therewith, said ring being mounted to said cap member in a groove defined by said external screw type thread.

52. The assembly recited in claim 47 wherein said cap member is provided with a longitudinally extending bore traversed in a substantially transversely oriented plane by a flexible self-sealing membrane element.

53. The vial assembly set forth in claim 47 wherein said receptacle defines a cavity, further comprising means inside said receptacle for dividing said cavity into multiple storage chambers accessible through said opening.

54. The assembly recited in claim 53 wherein said means for dividing includes at least one partition member inserted into said cavity and engaging an inner surface of said receptacle.

55. The assembly recited in claim 54 wherein said partition member is disposed in said cavity in a transversely oriented plane.

56. The assembly recited in claim 54 wherein said partition member is provided with a longitudinally extending bore traversed in a substantially transversely oriented plane by a flexible self-sealing membrane element.

57. The assembly recited in claim 54 wherein said

- 38 -

partition member is provided with sealing means engaging said inner surface for forming a fluid tight seal therewith.

58. The assembly recited in claim 53 wherein said chambers are axially disposed relative to said vial.

59. The assembly recited in claim 53 wherein said cavity has a length dimension and a width dimension, said means for dividing including an ampule having an external length dimension smaller than the length dimension of said cavity and a width dimension smaller than the width dimension of said cavity.

60. The assembly recited in claim 59, further comprising an additional ampule having an external length dimension smaller than one-half of the length dimension of said cavity and an external width dimension smaller than the width dimension of said cavity.

61. The vial assembly set forth in claim 47 wherein said receptacle takes the form of a cylindrical tube, said outer surface being cylindrical and said outer transverse dimension being a diameter, said sealing member taking the form of a ring.

62. A cap member for a vial assembly, comprising:
a substantially cup-shaped body having a substantially cylindrical outer surface;
an external screw type thread on body extending from a rim thereof, said thread defining a groove; and
a ring seal seated in said groove, said ring seal extending in a radial direction substantially beyond said outer surface to form a support flange.

63. A vial assembly comprising:
a cylindrical vial having a cylindrical outer surface with an outer diameter, said vial having an opening at one of two opposite ends, said vial being further provided with an internal screw type thread at said opening;
a cap member provided with an external screw type

- 39 -

thread interlocking with said internal screw type thread to removably attach said cap member to said vial at said opening, whereby said cap member covers said opening, said external screw type thread defining a groove; and

a ring-shaped sealing member seated in said groove to form a seal between said vial and said cap member, said sealing member having an outer dimension greater than said outer diameter so that said sealing member projects beyond said outer surface and forms a support for the vial assembly.

64. A method for use in preparing a biological sample, comprising the steps of:

upon the birth of an individual, obtaining at least a portion of a placenta and an associated umbilical cord which extended from said individual to the placenta;

extracting a first tissue sample from said portion of the placenta and umbilical cord;

extracting a second tissue sample from said portion of the placenta and umbilical cord;

providing a storage receptacle having at least two chambers;

depositing the extracted first tissue sample in one of said chambers;

depositing the extracted second tissue sample in another of said chambers; and

storing said receptacle.

65. The method set forth in claim 64 wherein said first tissue sample is fetal blood fluid, further comprising the step of adding an anticoagulant to said fetal blood fluid.

66. The method set forth in claim 65 wherein said second tissue sample is DNA.

67. The method set forth in claim 66, further comprising the step of recording identification information as to said individual.

68. The method set forth in claim 67 wherein said step of recording includes the step of placing an identifica-

- 40 -

tion tag on said receptacle.

69. The method set forth in claim 68 wherein said identification tag includes a bar code encoding said identification information.

70. The method set forth in claim 66 wherein said step of storing includes the step of placing said receptacle in a long term storage unit.

71. The method set forth in claim 70 wherein said long-term storage unit is a cryogenic storage unit.

72. The method set forth in claim 66 wherein said step of extracting DNA includes the step of extracting DNA from a T-cell.

73. The method set forth in claim 64, further comprising the step of recording identification information as to said individual.

74. The method set forth in claim 73 wherein said step of recording includes the step of placing an identification tag on said receptacle.

75. The method set forth in claim 74 wherein said identification tag includes a bar code encoding said identification information.

76. The method set forth in claim 64, further comprising the step of recording identification information as to said individual.

77. The method set forth in claim 64 wherein said step of storing includes the step of placing said receptacle in a long term storage unit.

78. A method for use in preparing biological samples, comprising the steps of:
upon the birth of an individual, obtaining at least

- 41 -

a portion of a placenta and an associated umbilical cord which extended from said individual to the placenta;

extracting a first biological specimen from said portion of the placenta and umbilical cord;

extracting a second biological specimen from a parent of said individual;

providing a storage receptacle having at least two chambers;

depositing the extracted first biological specimen in one of said chambers;

depositing the extracted second biological specimen in another of said chambers; and

storing said receptacle.

79. The method set forth in claim 78 wherein said first biological specimen includes fetal blood fluid.

80. The method set forth in claim 79 wherein said second biological specimen includes blood fluid.

81. The method set forth in claim 80, further comprising the step of recording identification information as to said individual.

82. The method set forth in claim 81 wherein said step of recording includes the step of placing an identification tag on said receptacle.

83. The method set forth in claim 80, further comprising the steps of extracting a third biological specimen from said portion of the placenta and umbilical cord and depositing the extracted third biological specimen in an additional chamber of said storage receptacle.

84. The method set forth in claim 83 wherein said third biological specimen includes DNA.

85. The method set forth in claim 80 wherein said step of storing includes the step of placing said receptacle in a long term storage unit.

- 42 -

86. The method set forth in claim 78, further comprising the step of recording identification information as to said individual.

87. The method set forth in claim 86 wherein said step of recording includes the step of placing an identification tag on said receptacle.

88. The method set forth in claim 78 wherein said step of storing includes the step of placing said receptacle in a long term storage unit.

89. The method set forth in claim 78 wherein said first biological specimen is taken from the group consisting of umbilical vascular tissue and DNA.

90. The method set forth in claim 78 wherein said second biological specimen includes DNA.

91. A method for use in preparing biological samples, comprising the steps of:

extracting a first biological specimen from a biological specimen from a first individual;

extracting a second biological specimen from a biological specimen of a second individual related to said first individual;

providing a storage receptacle having at least two chambers;

depositing the extracted first biological specimen in one of said chambers;

depositing the extracted second biological specimen in another of said chambers; and

storing said receptacle.

92. The method set forth in claim 91 wherein said first individual and said second individual are siblings.

93. The method set forth in claim 92 wherein said first individual and said second individual are genetically

- 43 -

identical siblings.

94. The method set forth in claim 91 wherein said first individual and said second individual are parent and child.

95. The method set forth in claim 91 wherein said first biological specimen and said second biological specimen are selected from the group consisting of blood, DNA, and vascular cells.

96. A vial assembly comprising:
a plurality of modular storage units each including a body portion defining a storage chamber, a first connector on one side and a second connector on another side,
the first connector of each of said modular storage units being removably couplable to the second connector of each other one of said storage units,
each of said storage units being coupled via a respective first or second connector to at least one other of said storage units at a respective second or first connector.

97. The vial assembly set forth in claim 96 wherein said first connector and said second connector take the form of an internally screw-threaded portion and an externally screw-threaded portion, respectively.

98. The vial assembly set forth in claim 97, further comprising a cap connected to a terminal one of said storage units, said cap being provided with a magnetic element.

99. The vial assembly set forth in claim 96 wherein each of said storage units further includes access means including a flexible self-sealing membrane element for enabling access to the respective storage chamber.

100. A vial assembly comprising:
a plurality of modular storage sections each including a body portion defining a storage chamber, each of said storage sections further including access means for enabling

- 44 -

deposition of biological material into and extraction of biological material from the respective storage chamber; and coupling means for connecting said storage sections to one another in a substantially cylindrical or annular configuration wherein said storage sections extend parallel to a longitudinal axis of said configuration.

101. The vial assembly set forth in claim 100 wherein said coupling means includes a first connector on one side of each of said storage sections and a second connector on another side of each of said storage sections so that the first connector of each of said storage sections is removably coupleable to the second connector of another one of said storage sections.

102. The vial assembly set forth in claim 100 wherein said coupling means includes a connector element provided with means for releasably coupling each of said storage sections to said connector element to form said cylindrical configuration.

103. The vial assembly set forth in claim 100 wherein said modular storage sections each have a substantially pie-slice-shaped cross-section.

104. The vial assembly set forth in claim 100 wherein said access means includes a flexible self-sealing membrane element.

1/7

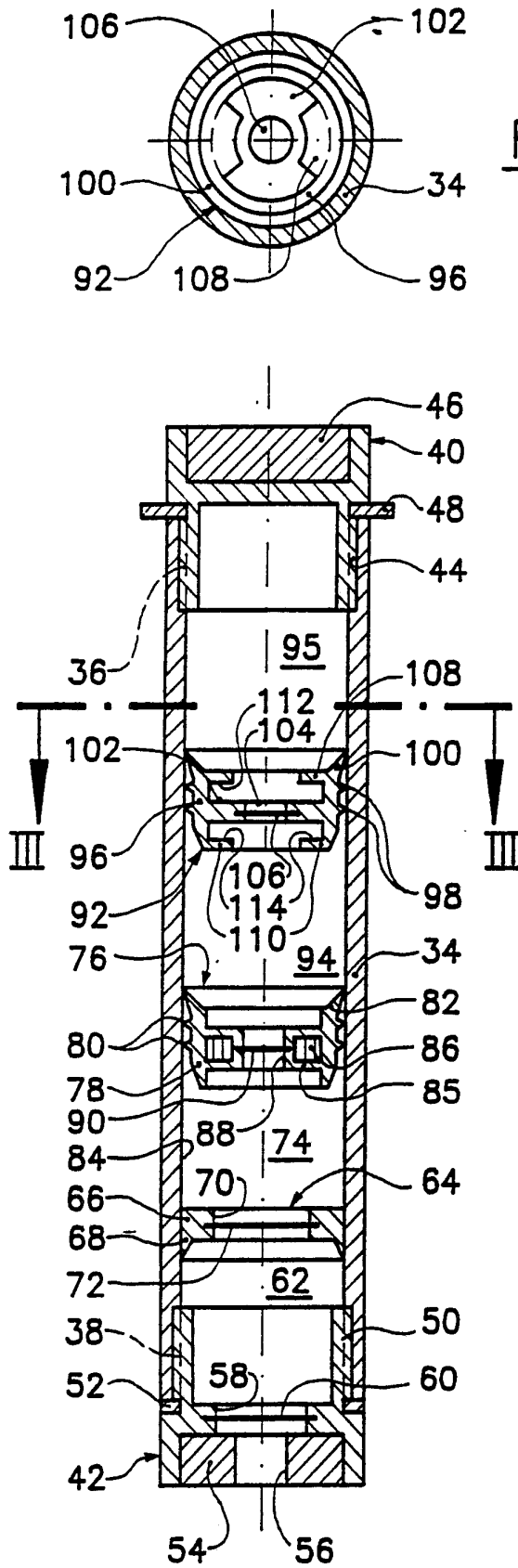

FIG. 2

FIG. 3

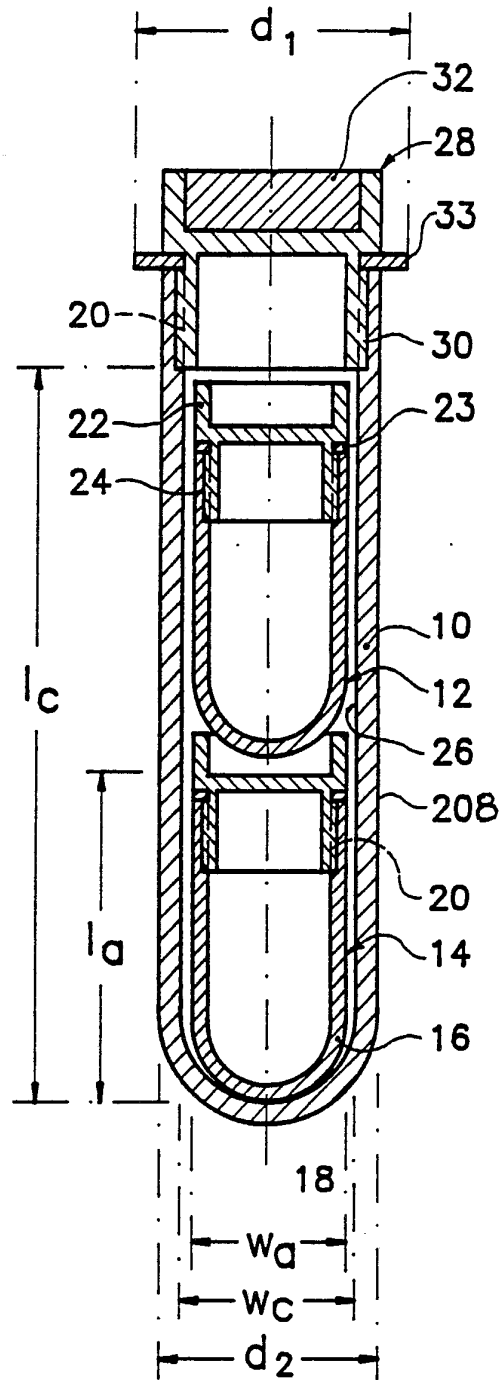

FIG. 1

2/7

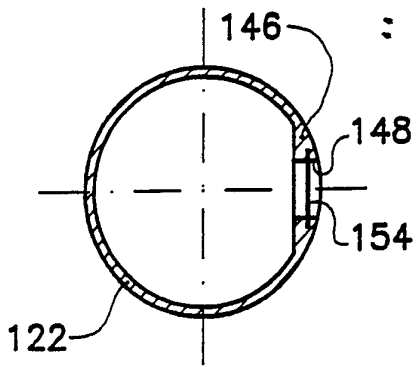

FIG. 5

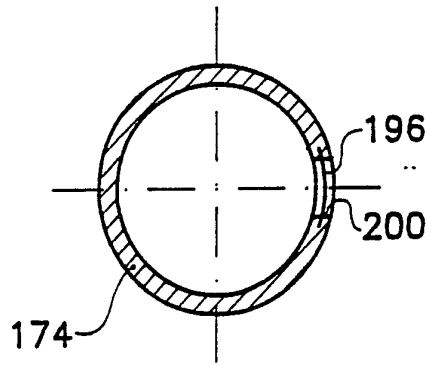

FIG. 7

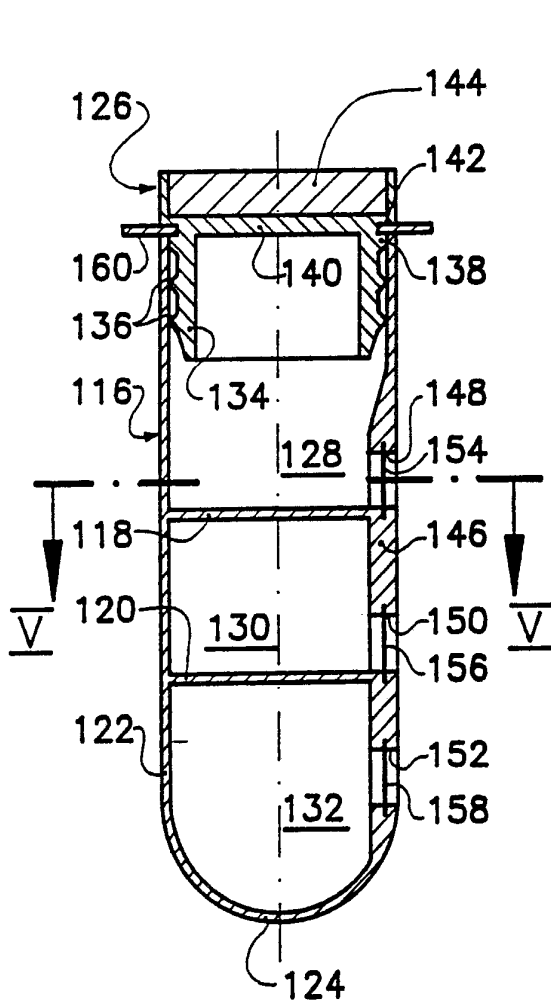

FIG. 4

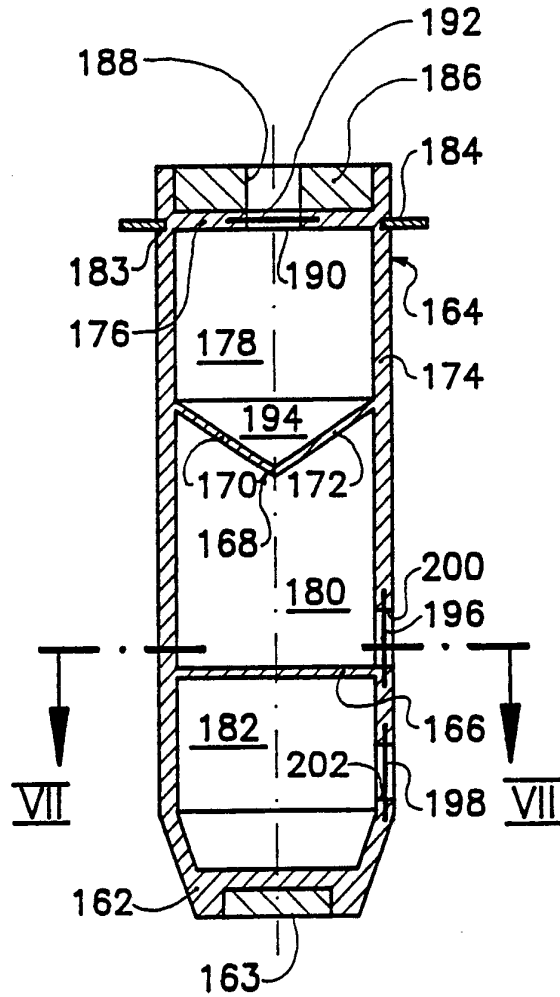

FIG. 6

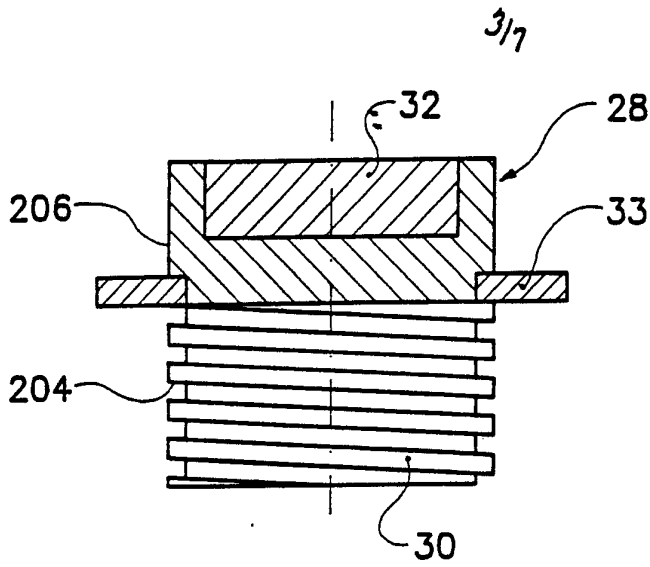

FIG. 8

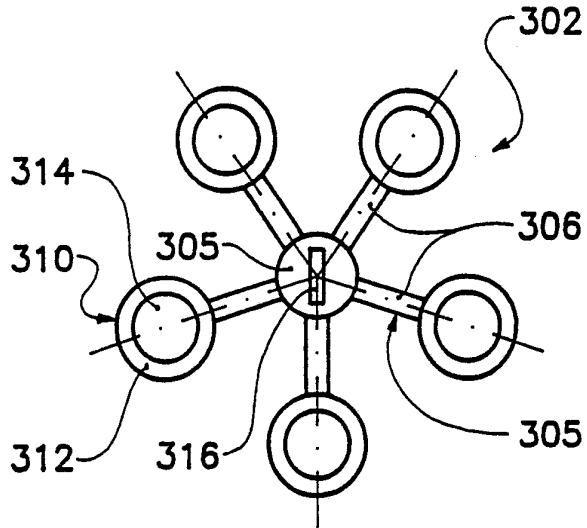

FIG. 9

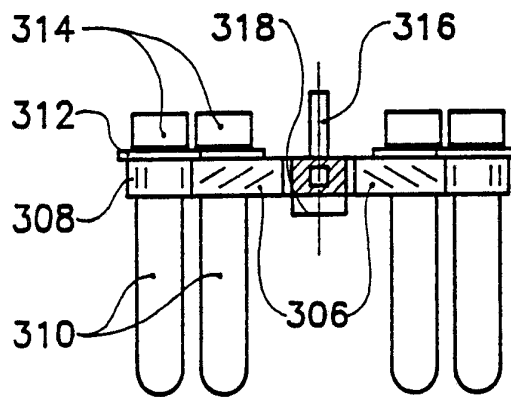

FIG. 10

4/7

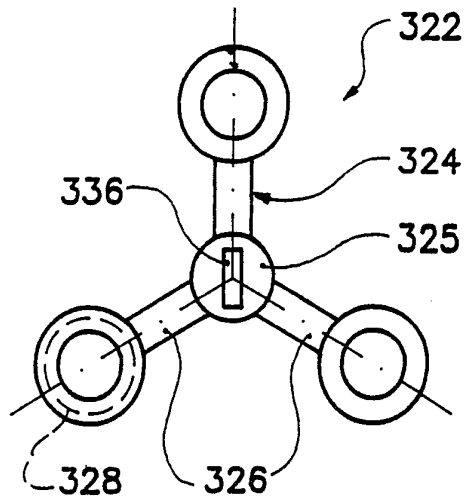

FIG. 11

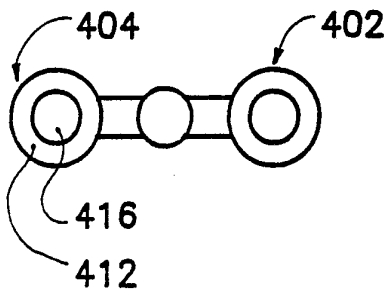

FIG. 12

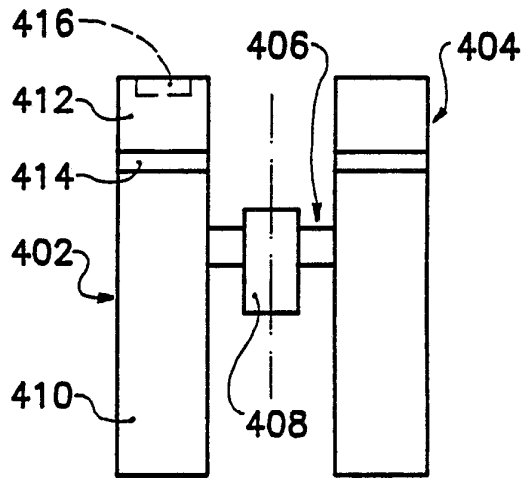

FIG. 13

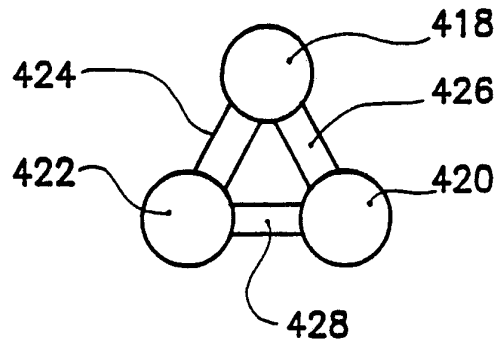

FIG. 14

5/7

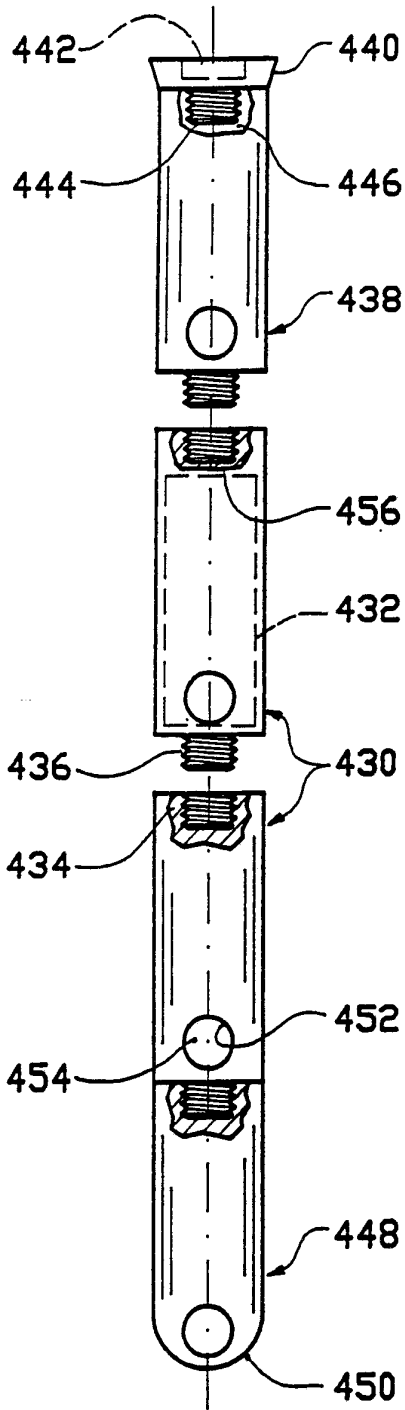

FIG.15

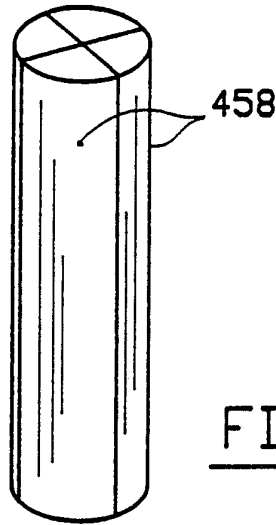

FIG.16

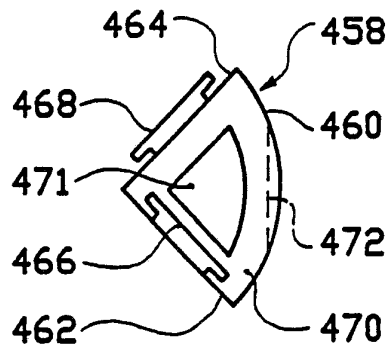

FIG.17

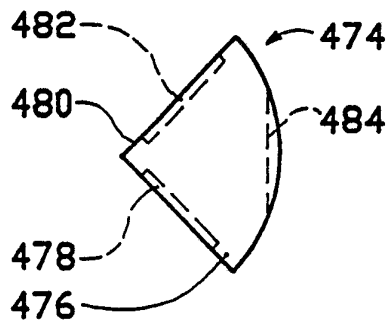

FIG.18

6/7

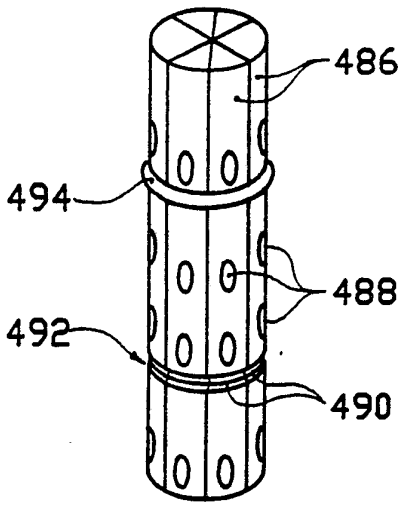

FIG.19

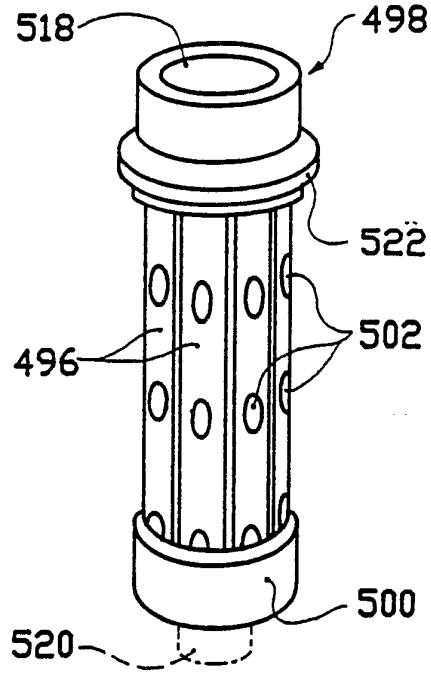

FIG.20

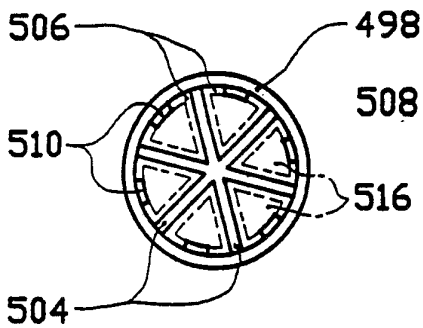

FIG.21

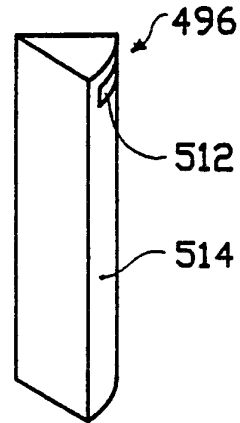

FIG.22

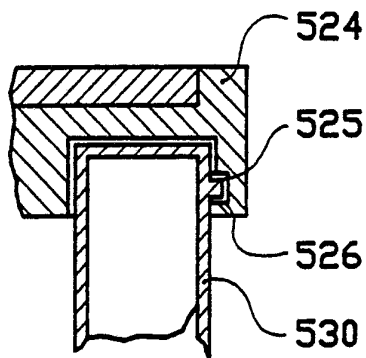

FIG.23

7/7

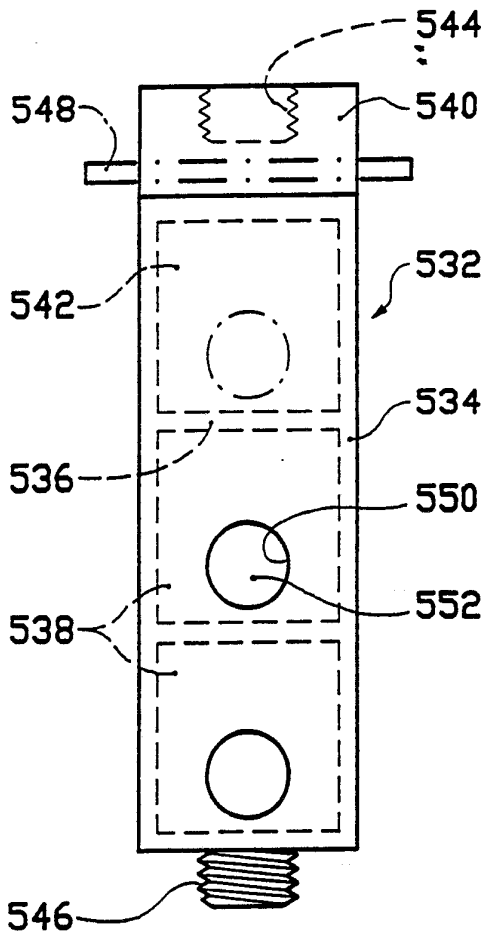

FIG. 24

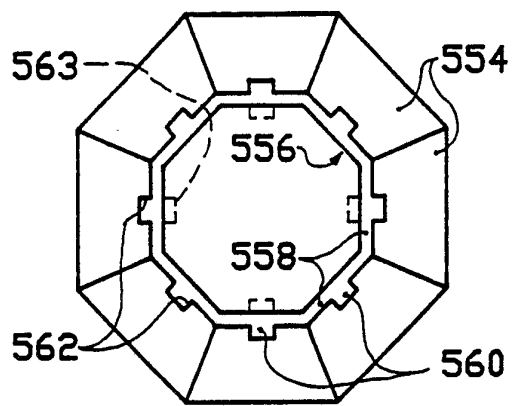

FIG. 25

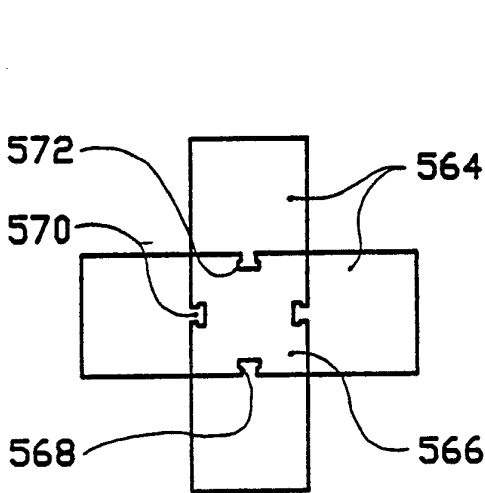

FIG. 26

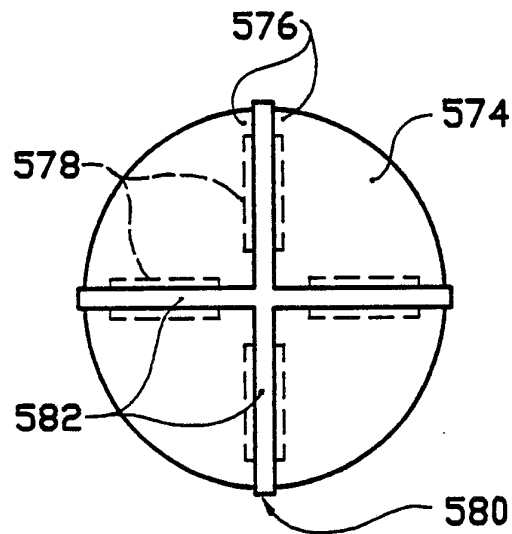

FIG. 27

INTERNATIONAL SEARCH REPORT

International Application No. PCT/US91/07006

| | | | | |
|---|--|---|---|--|
| I. CLASSIFICATION OF SUBJECT MATTER (if several classification symbols apply, indicate all) ⁶ | | | | |
| According to International Patent Classification (IPC) or to both National Classification and IPC IPC(5):B01L 3/00; B65D 1/04, 41/02 U.S. CL.: 422/102, 104; 215/6,10,247; 206/569; 220/230 | | | | |
| II. FIELDS SEARCHED | | | | |
| Minimum Documentation Searched ⁷ | | | | |
| Classification System | Classification Symbols | | | |
| U.S. | 422/102,104; 215/6,10,247; 206/569; 220/230 | | | |
| Documentation Searched other than Minimum Documentation to the Extent that such Documents are Included in the Fields Searched ⁸ | | | | |
| III. DOCUMENTS CONSIDERED TO BE RELEVANT ⁹ | | | | |
| Category ⁹ | Citation of Document, ¹¹ with indication, where appropriate, of the relevant passages ¹² | Relevant to Claim No. ¹³ | | |
| X Y | US. A. 3.842.836 (Ogle) 22 October 1974 (See col. 4, lines 26-34). | 1-4.6.7.9 10.12.16. 17.19.20. 22 & 24 5.8.11. 13-15.18. 21 & 23 | | |
| Y | US. A. 4.492.634 (Villa-Real) 08 January 1985 (See col. 3. lines 42-53). | 5.8.11. 13-15.18. 21 & 23 | | |
| A | US. A. 2.660.171 (Dickinson, Jr.) 24 November 1953 (See figures 1-4). | 1-24 | | |
| A | US. A. 4.089.432 (Crankshaw et al.) 16 May 1978 (See Figure 2). | 1-24 | | |
| A | US. A. 2.908.274 (Bujan) 13 October 1959 (See Figures 1 and 2) | 1-24 | | |
| <table style="width: 100%; border: none;"> <tr> <td style="width: 50%; vertical-align: top; padding: 5px;"> <ul style="list-style-type: none"> * Special categories of cited documents: ¹⁰ "A" document defining the general state of the art which is not considered to be of particular relevance "E" earlier document but published on or after the international filing date "L" document which may throw doubts on priority claim(s) or which is cited to establish the publication date of another citation or other special reason (as specified) "O" document referring to an oral disclosure, use, exhibition or other means "P" document published prior to the international filing date but later than the priority date claimed </td> <td style="width: 50%; vertical-align: top; padding: 5px;"> <ul style="list-style-type: none"> "T" later document published after the international filing date or priority date and not in conflict with the application but cited to understand the principle or theory underlying the invention "X" document of particular relevance; the claimed invention cannot be considered novel or cannot be considered to involve an inventive step "Y" document of particular relevance; the claimed invention cannot be considered to involve an inventive step when the document is combined with one or more other such documents, such combination being obvious to a person skilled in the art. "&" document member of the same patent family </td> </tr> </table> | | | <ul style="list-style-type: none"> * Special categories of cited documents: ¹⁰ "A" document defining the general state of the art which is not considered to be of particular relevance "E" earlier document but published on or after the international filing date "L" document which may throw doubts on priority claim(s) or which is cited to establish the publication date of another citation or other special reason (as specified) "O" document referring to an oral disclosure, use, exhibition or other means "P" document published prior to the international filing date but later than the priority date claimed | <ul style="list-style-type: none"> "T" later document published after the international filing date or priority date and not in conflict with the application but cited to understand the principle or theory underlying the invention "X" document of particular relevance; the claimed invention cannot be considered novel or cannot be considered to involve an inventive step "Y" document of particular relevance; the claimed invention cannot be considered to involve an inventive step when the document is combined with one or more other such documents, such combination being obvious to a person skilled in the art. "&" document member of the same patent family |
| <ul style="list-style-type: none"> * Special categories of cited documents: ¹⁰ "A" document defining the general state of the art which is not considered to be of particular relevance "E" earlier document but published on or after the international filing date "L" document which may throw doubts on priority claim(s) or which is cited to establish the publication date of another citation or other special reason (as specified) "O" document referring to an oral disclosure, use, exhibition or other means "P" document published prior to the international filing date but later than the priority date claimed | <ul style="list-style-type: none"> "T" later document published after the international filing date or priority date and not in conflict with the application but cited to understand the principle or theory underlying the invention "X" document of particular relevance; the claimed invention cannot be considered novel or cannot be considered to involve an inventive step "Y" document of particular relevance; the claimed invention cannot be considered to involve an inventive step when the document is combined with one or more other such documents, such combination being obvious to a person skilled in the art. "&" document member of the same patent family | | | |
| IV. CERTIFICATION | | | | |
| Date of the Actual Completion of the International Search | | Date of Mailing of this International Search Report | | |
| 09 January 1992 | | 27 JAN 1992 | | |
| International Searching Authority | | Signature of Authorized Officer | | |
| ISA/US | | Laura Collins ebw | | |