

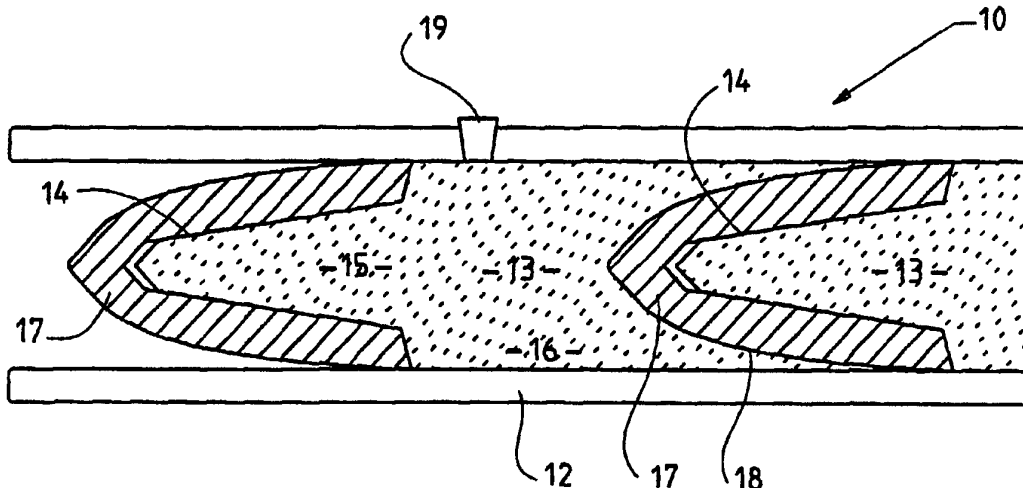

INTERNATIONAL APPLICATION PUBLISHED UNDER THE PATENT COOPERATION TREATY (PCT)

<p>(51) International Patent Classification<sup>6</sup> : F41A 21/00, 21/06, 21/28</p>	<p>A1</p>	<p>(11) International Publication Number: <b>WO 97/04281</b> (43) International Publication Date: 6 February 1997 (06.02.97)</p>
<p>(21) International Application Number: PCT/AU96/00459 (22) International Filing Date: 19 July 1996 (19.07.96) (30) Priority Data: PN 4265 19 July 1995 (19.07.95) AU (71)(72) Applicant and Inventor: O'DWYER, James, Michael [AU/AU]; 12 Peppertree Street, Sinnamon Park, QLD 4073 (AU). (74) Agent: PIZZEYS; Trustee House, Level 6, 444 Queen Street, Brisbane, QLD 4000 (AU).</p>	<p>(81) Designated States: AL, AM, AT, AU, AZ, BB, BG, BR, BY, CA, CH, CN, CU, CZ, DE, DK, EE, ES, FI, GB, GE, HU, IL, IS, JP, KE, KG, KP, KR, KZ, LK, LR, LS, LT, LU, LV, MD, MG, MK, MN, MW, MX, NO, NZ, PL, PT, RO, RU, SD, SE, SG, SI, SK, TJ, TM, TR, TT, UA, UG, US, UZ, VN, ARIPO patent (KE, LS, MW, SD, SZ, UG), Eurasian patent (AM, AZ, BY, KG, KZ, MD, RU, TJ, TM), European patent (AT, BE, CH, DE, DK, ES, FI, FR, GB, GR, IE, IT, LU, MC, NL, PT, SE), OAPI patent (BF, BJ, CF, CG, CI, CM, GA, GN, ML, MR, NE, SN, TD, TG).  <b>Published</b> <i>With international search report.</i></p>	

(54) Title: BARREL ASSEMBLY WITH AXIALLY STACKED PROJECTILES



(57) Abstract

A barrel assembly (10) having a plurality of projectiles (11) stacked axially within the barrel (12) together with discrete selectively ignitable propellant charges (13) for propelling the projectiles (11) sequentially through the muzzle of the barrel (12) is provided with adjacent projectiles (11) separated from one another by locating means (13) independent of the projectiles. The locating means may be a solid propellant charge (13) located between adjacent projectiles or it may be a rigid casing (122) for the propellant. When subject to an in-barrel load a rear skirt portion of the active projectile (11) is expanded outwardly by the interaction between an inwardly reducing recess (14) formed in the rear end of a projectile and the nested complementary leading portion of the propellant charge (13) or propellant casing (122).

**FOR THE PURPOSES OF INFORMATION ONLY**

Codes used to identify States party to the PCT on the front pages of pamphlets publishing international applications under the PCT.

AM	Armenia	GB	United Kingdom	MW	Malawi
AT	Austria	GE	Georgia	MX	Mexico
AU	Australia	GN	Guinea	NE	Niger
BB	Barbados	GR	Greece	NL	Netherlands
BE	Belgium	HU	Hungary	NO	Norway
BF	Burkina Faso	IE	Ireland	NZ	New Zealand
BG	Bulgaria	IT	Italy	PL	Poland
BJ	Benin	JP	Japan	PT	Portugal
BR	Brazil	KE	Kenya	RO	Romania
BY	Belarus	KG	Kyrgyzstan	RU	Russian Federation
CA	Canada	KP	Democratic People's Republic of Korea	SD	Sudan
CF	Central African Republic	KR	Republic of Korea	SE	Sweden
CG	Congo	KZ	Kazakhstan	SG	Singapore
CH	Switzerland	LI	Liechtenstein	SI	Slovenia
CI	Côte d'Ivoire	LK	Sri Lanka	SK	Slovakia
CM	Cameroon	LR	Liberia	SN	Senegal
CN	China	LT	Lithuania	SZ	Swaziland
CS	Czechoslovakia	LU	Luxembourg	TD	Chad
CZ	Czech Republic	LV	Latvia	TG	Togo
DE	Germany	MC	Monaco	TJ	Tajikistan
DK	Denmark	MD	Republic of Moldova	TT	Trinidad and Tobago
EE	Estonia	MG	Madagascar	UA	Ukraine
ES	Spain	ML	Mali	UG	Uganda
FI	Finland	MN	Mongolia	US	United States of America
FR	France	MR	Mauritania	UZ	Uzbekistan
GA	Gabon			VN	Viet Nam

## BARREL ASSEMBLY WITH AXIALLY STACKED PROJECTILES

TECHNICAL FIELD

The invention relates to munitions and firearms.

This invention has particular, but not exclusive,  
5 application to a barrel having a plurality of projectiles  
stacked axially within the barrel together with discrete  
selectively ignitable propellant charges for propelling the  
projectiles sequentially through the muzzle of the barrel.  
Such barrels will be referred to hereinafter as of the type  
10 described.

BACKGROUND ART

International Patent Application No. PCT/AU94/00124  
relates to firearms of the type described. Field tests of  
prototype versions of firearms utilizing barrels of the type  
15 described have shown that such barrel assemblies perform to  
expectations. However the inventor has proposed useful  
variations, including munitions, as well as improvements  
which may assist in either the efficient production of such  
firearms or facilitate their performance or useability.  
20 Furthermore the inventor envisages that single barrel rates  
of fire in excess of 40,000 rounds/minute may be achievable  
in practice and this possibility creates further scope for  
munitions of conventional style and firearms utilizing  
barrels of the type described.

25 DISCLOSURE OF INVENTION

According to one aspect this invention provides a barrel  
assembly of the type described, wherein:-

adjacent projectiles are separated from one another and  
maintained in spaced apart relationship by locating means  
30 separate from the projectiles, and

each projectile includes expandable sealing means for  
forming an operative seal with the bore of the barrel.

The locating means may be the propellant charge between  
adjacent projectiles and the sealing means suitably includes  
35 a skirt portion of each projectile which expands outwardly  
when subject to an in-barrel load. The in-barrel load may be

applied during installation of the projectiles or after loading such as by tamping to consolidate the column of projectiles and propellant charges or it may result from the firing of an outer projectile and particularly the adjacent  
5 outer projectile.

The propellant charge may be form as a solid block to operatively space the projectiles in the barrel or the propellant charge may be encased in metal or other rigid case which may include an embedded primer having external contact  
10 means adapted for contacting an pre-positioned electrical contact associated with the barrel. For example the primer could be provided with a sprung contact which may be retracted to enable insertion of the cased charge into the barrel and to spring out into a barrel aperture upon  
15 alignment with that aperture for operative contact with its mating barrel contact. If desired the outer case may be consumable or may chemically assist the propellant burn. Furthermore an assembly of stacked and bonded or separate cased charges and projectiles may be provide for reloading a  
20 barrel.

The rear end of the projectile may be formed with a skirt about an inwardly reducing recess such as a conical recess or a part-spherical recess or the like into which the propellant charge portion extends and about which rearward  
25 movement of the projectile will result in radial expansion of the projectile skirt. This rearward movement may occur by way of compression resulting from a rearward wedging movement of the projectile along the leading portion of the propellant charge it may occur as a result of metal flow from the  
30 relatively massive leading part of the projectile to its less massive skirt portion.

Alternatively the projectile may be provided with a rearwardly divergent peripheral sealing flange or collar which is deflected outwardly into sealing engagement with the  
35 bore upon rearward movement of the projectile. Furthermore the sealing may be effected by inserting the projectiles into

a heated barrel which shrinks onto respective sealing portions of the projectiles. Then again the projectile may comprise a relatively hard mandrel portion located by the propellant charge and which cooperates with a deformable  
5 annular portion supported thereabout for expansion into operative sealing engagement with the bore. The deformable annular portion may be moulded about the mandrel to form a unitary projectile which relies on metal flow between the nose of the projectile and its tail for outward expansion  
10 about the mandrel portion into sealing engagement with the bore of the barrel.

In a further embodiment the projectile assembly includes a rearwardly expanding anvil surface supporting a sealing collar thereabout and adapted to be radially expanded into  
15 sealing engagement with the barrel bore upon forward movement of the projectile through the barrel. In such embodiment it is preferred that the propellant charge have a cylindrical leading portion which abuts the flat end face of the projectile.

20 If desired, the projectiles may be adapted for seating and/or location within circumferential grooves or by annular ribs in the bore or in rifling grooves in the bore and may include a metal jacket encasing at least the outer end portion of the projectile. The projectile may be provided  
25 with contractible peripheral locating rings which extend outwardly into annular grooves in the barrel and which retract into the projectile upon firing to permit its free passage through the barrel.

In another aspect this invention resides broadly in a  
30 method of electrical ignition for sequentially igniting the propellant charges of a barrel assembly of the type described, including:-

igniting the leading propellant charge by sending an ignition signal through the stacked projectiles, and  
35 causing ignition of the leading propellant charge to arm the next propellant charge for actuation by the next ignition

signal. Suitably all propellant charges inwardly from the end of a loaded barrel are disarmed by the insertion of respective insulating fuses disposed between normally closed electrical contacts.

5 Ignition of the propellant may be achieved electrically or ignition may utilise conventional firing pin type methods such as by using a centre-fire primer igniting the outermost projectile and controlled consequent ignition causing sequential ignition of the propellant charges of subsequent  
10 rounds. This may be achieved by controlled rearward leakage of combustion gases or controlled burning of fuse columns extending through the projectiles.

In another form the ignition is electronically controlled with respective propellant charges being  
15 associated with primers which are triggered by distinctive ignition signals. For example the primers in the stacked propellant charges may be sequenced for increasing pulse width ignition requirements whereby electronic controls may selectively send ignition pulses of increasing pulse widths  
20 to ignite the propellant charges sequentially in a selected time order. Preferably however the propellant charges are ignited by a set pulse width signal and burning of the leading propellant charge arms the next propellant charge for actuation by the next emitted pulse.

25 Suitably in such embodiments all propellant charges inwardly from the end of a loaded barrel are disarmed by the insertion of respective insulating fuses disposed between normally closed electrical contacts, the fuses being set to burn to enable the contacts to close upon transmission of a  
30 suitable triggering signal and each insulating fuse being open to a respective leading propellant charge for ignition thereby.

A number of projectiles can be fired simultaneously, or in quick succession, or in response to repetitive manual  
35 actuation of a trigger, for example. In such arrangements the electrical signal may be carried externally of the barrel

or it may be carried through the superimposed projectiles which may clip onto one another to continue the electrical circuit through the barrel, or abut in electrical contact with one another. The projectiles may carry the control  
5 circuit or they may form a circuit with the barrel.

An advantage which is likely to be gained from dispensing with externally fired primers is the removal of lateral forces within the barrel from firing of the wall mounted primers and the resultant uneven deposit from the  
10 primer firing on the projectile and/or barrel. This may increase the accuracy of such weapons and simplify refurbishing of used barrels.

In a further aspect this invention resides broadly in a cased round including:-

15 a case adapted for retention in a breech assembly;  
at least two projectiles disposed one behind the other in the case and each being sealably engaged therewith;  
respective propellant charges within the case and behind each projectile, and  
20 ignition means for igniting the charges in a predetermined sequence. The ignition means may be an electrical ignition means of the type described above or in the abovementioned earlier International Patent Application, but preferably the ignition means utilises mechanical  
25 operation of pin fired primers.

The pin fired primer may be adapted to ignite the outermost propellant charge which burns back to ignite the rear charge, but preferably the case is provided with respective primers associated with separate pins for firing  
30 the primers. Suitably the primers includes a centre-fire primer associated with a rearwardly extending tubular central spine of the rearmost projectile assembly providing a gas path or burn path for conveying the primer burn to the forward propellant and a rim-fire primer for igniting the  
35 rear propellant charge. Alternatively the hollow rear spine may be independent of the rear projectile and support an

extension pin conveying the mechanical pin action to a primer supported at within or forwardly of the rear projectile and communicating with the forward propellant.

If desired the centre-fire primer may be associated with  
5 the rear propellant charge and the rim fire primer may be disposed in the casing wall in direct communication with the outermost or an outer charge.

The mechanical impacts with the primers may be in quick succession so as to enable both projectiles to be fired  
10 sequentially at a rapid rate, such as at a rate of greater than 40,000 rounds per minute. For this purpose where both primers are associated with the base of the cartridge the firing pins may be formed integrally, with the outer pin being slightly shorter than the central pin for the required  
15 actuating delay. Suitably the cased ammunition is adapted for use with a rifle or hand gun which includes a preset time delay for, or be provided with a selectively variable timing differential between, actuation of the firing pins.

The timing of the firing of a pair of adjacent  
20 projectiles in the above cased ammunition embodiment or in the barrel assembly may be such as to delay ignition of the forward propellant until after the adjacent projectiles have moved as an assembly part-way down the barrel in response to ignition of the rear propellant. This arrangement is  
25 proposed as a means of increasing the velocity of the forward projectile. That is the kinetic energy of the rear projectile of a pair of projectiles is sacrificed to enhance the kinetic energy of the front projectile. Alternatively  
30 the firing of the rear propellant may follow the firing of the forward propellant simultaneously or almost immediately while the leading projectile remains in the barrel to impart its effect, at least in part, to the forward projectile.

Another variation of the present invention which may be applied to the barrel version or the cased ammunition version  
35 of the invention aims to deflect the projectile from its axial path on exiting the barrel by providing a gas bypass



passage adjacent the muzzle which feeds propellant gases back to the barrel in the path of the projectile so as to deflect its trajectory from the end of the barrel. In a preferred form such modified barrels are arranged as a cluster of  
5 barrels with the bypass bleed inlets innermost so that the lateral reaction forces produced cancel one another.

Furthermore ammunition utilizing a rearwardly extending spine may be provided with flight stabilizers such as fins which may be utilized to cause rotation of the projectile to  
10 cause rotation in a projectile fired from a smooth bore barrel, or to provide a non-rotating flight projectile. Additionally, projectiles may utilize a spine which projects forwardly from the nose of the projectile to provide the separation for propellant. Where means are used to induce  
15 rotation of the projectile such as barrel rifling, it may be advantageous to form the two part projectiles with opposite hand coarse or fine joining threads so that the rotation caused by the rifling tends to bind the parts together and not separate them as may be the case where the two part  
20 junction does not inhibit independent axial rotation of the projectile parts.

#### BRIEF DESCRIPTION OF DRAWINGS

In order that this invention may be more readily understood and put into practical effect, reference will now  
25 be made to the accompanying drawings which illustrate typical embodiments of the present inventions.

FIG. 1 is a sectional view of part of a barrel assembly utilising propellant spacing of projectiles;  
FIG. 2 is a sectional view of a further form of barrel  
30 assembly utilising propellant spacing of projectiles;  
FIG. 3 is a sectional view of part of a barrel assembly of another embodiment of the invention utilising propellant spacing of projectiles;  
FIG. 4 is a sectional view illustrating an internal  
35 ignition system of a barrel assembly utilising spine spacing of projectiles;

FIG. 5 illustrates a further embodiment which is similar to that of Fig. 4;

FIG. 6a illustrates one form of double-tap ammunition;

5 FIG. 6b illustrates the sequence from loaded to cartridge ejection of the ammunition illustrated in Fig. 6a;

FIGS. 7a to 7d illustrate further forms of double-tap ammunition;

10 FIG. 8 illustrates an electrically fired form of cased ammunition;

FIG. 9 illustrates a high energy transfer projectile for use with the double tap ammunition or a barrel assembly of the type described;

15 FIG. 10 illustrates an end part of a barrel assembly provided with projectile deflecting means;

FIG. 11 illustrates a barrel arrangement for a multiple barrel array;

FIG. 12 illustrates a weapon adapted for the double-tap ammunition;

20 FIG. 13a to 13e illustrate the operational sequence of the weapon of Fig 13;

FIGS. 14a and 14b illustrate recoil control arrangements;

FIG. 15 illustrates a further projectile form;

25 FIG. 16 is a diagrammatic sectional view of a four barrel cluster, and

FIG. 17 illustrates the loading mechanism for the embodiment of Fig. 16.

30 Fig. 1 illustrates a barrel assembly 10 of the type described having spaced projectiles 11 loaded within the barrel 12 in spaced relationship and separated by respective propellant blocks 13. As illustrated each projectile 11, which may be formed of lead or other malleable material, is provided with a part-conical recess 14 at its trailing end to accommodate the  
35 correspondingly shaped leading portion 15 of the

propellant block 13. The main body 16 of the propellant block 13 is cylindrical and its rear end is recessed to closely accommodate the nose 17 of the next-in-line projectile 18. In this embodiment, external primers 19  
5 extend through the wall of the barrel 12 whereby ignition of the respective propellant blocks can be controlled by an external electronic control circuit, not illustrated.

In use, the firing of a forward projectile 11 results in  
10 a reaction force being applied of the next projectile 18 which either moves rearwardly over the conical portion of the propellant to wedge into tight sealing engagement with the inner wall of the barrel 12 or deforms without movement relative to the projectile by metal flow towards the rear of  
15 the projectile to effect the seal with the inner wall of the barrel 12. Thereafter, upon ignition of the following propellant block, the seal so formed will provide the necessary barrier against propellant gases escaping to ensure effective energy transfer to the projectile 18.

20 The barrel assembly 20 illustrated in Fig. 2 is similar to that illustrated in Fig. 1 except that the projectile 21 is a two part projectile containing a head part 22 and an anvil part 23 which abuts the relatively flat front face of the propellant block 24 and which performs the same sealing  
25 function as the conical portion of the propellant of Fig. 1.

Fig. 3 illustrates portion of a further barrel assembly  
30 of the type described in which a series of projectile assemblies 31 are spaced apart by solid propellant charges 32 which have a plain cylindrical leading portion 33 and a  
30 recessed rear portion 34 to accommodate the nose of the following projectile. In this embodiment, the projectile has a steel spine 36 integral with a nose 35 and end cap 37 which is a sliding fit within the barrel 38 and seats against the front face of the propellant charge 32. A collar 39 of more  
35 dense material such as lead or the like extends about the forwardly expanding spine portion and into recesses 26 formed

in the bore. The collar may be encased in a thin-walled metal jacket in known manner.

In this embodiment, the projectile assembly is seated fully in position either by tamping against the nose 35  
5 during assembly so as to force the spine 36 rearwardly, whereby the interaction of the complementary conical faces 27 and 28 expands the collar 39 outwardly into sealing engagement within the grooves 26 in which they are initially set, or by the reaction from ignition of the leading  
10 propellant. The leading faces of the grooves 26 are more inclined than the rear faces of the groove, as illustrated, so as to assist in disengagement of the collar upon firing.

In such embodiments as described above, the amount of propellant supported between projectile assemblies is not  
15 limited by the length of the spine between propellants as in a barrel of the type described and having slender columns independent of the propellant separating the projectiles. Thus such embodiments may be useful in providing high muzzle velocity projectiles.

20 In my earlier barrels of the type described, the firing of the propellant has been achieved by the use of externally mounted primers associated with an external electronic control circuit. However in the embodiment of the invention illustrated in Fig. 4, each projectile assembly 40 includes  
25 an electrically conductive spine assembly 41 having a central portion which abuts with the adjacent projectile assemblies to form a continuous column and an electrical circuit branch throughout the length of the barrel.

The spine assembly 41, which in this embodiment also  
30 includes a central tapered mandrel portion 42 is insulated by an insulating layer 43 from the projectile head 44. The spine assemblies 41 abut at 45 whereby the electrical circuit is continued through the column of superimposed spine assemblies. A spring contact portion 48 extends forwardly  
35 from the leading end portion 46 of the spine assembly 41 and contacts the spine of the next projectile to complete the

circuit branch and a fixed contact 49 is supported in the insulated space 43 between the spine assembly 41 and the head 44. The fixed contact 49 is connected by lead 47 to one side of an electrically operated primer 50 which is also connected  
5 by lead 51 to the electrically conductive head 44 which is in electrical contact with the barrel 53.

In this embodiment, each primer 50 is pulse sensitive for ignition upon receipt of a suitable signal and the contacts 48 and 49 are spaced apart by an insulating fuse 52  
10 which extends through the nose of the projectile for ignition by the burn of the leading propellant charge. Thus in operation, an electrical pulse may be sent to the outermost primer to ignite the associated propellant and propel the first projectile assembly from the barrel.

15 That action will ignite the insulating fuse 52 which will maintain the contacts 48 and 49 apart for sufficient time to ensure that the following propellant is not ignited until after the contacts 48 and 49 come together to close the open circuit condition. The following primer may then be  
20 ignited at any time by sending the appropriate pulse through the circuit.

It is considered that reliability of the front contacts will be assured after firing as the carbon remnants of the charge or fuse will provide the appropriate electrical path  
25 between the contacts 48 and 49 even if they do not come into contact with one another. Thus, no external electrical wiring is required and such barrels may be stacked in close abutting relationship to form a compact weapon.

Fig. 5 illustrates a embodiment which is similar to Fig.  
30 4. However the electrical circuits for igniting the primers 50 are individually hard wired along the column 55 through the insulated space 43, which also extends along the rear spine extension 56, and operated separated by a control circuit. These wires 54 break away upon firing the  
35 respective projectile.

Fig. 6a illustrates a preferred form of double-tap round

60 comprising a shell 61 having a flanged base 62 supporting a centre-fire primer 63 and a rim-fire primer 64, a leading projectile 65, a trailing projectile 66 and propellant charges 67 and 68 associated with the respective projectile  
5 65 and 66.

Each projectile includes a spine part 69 which has a trailing column portion and a leading tapered mandrel portion 71 about which the nose 72 of the bullet extends such that firing of the projectile will force the mandrel 71 into the  
10 nose part to spread it into sealing engagement with the barrel. The column portion of the trailing projectile is hollow and is provided with leading outlet ports 73 which communicate with the leading propellant charge 67.

This arrangement is provided so that firing of the  
15 centre-fire primer 63 will ignite the leading propellant charge 67 only, the rear propellant charge 68 being ignited by the rim-fire primer 64. The firing rate of the two projectiles may be set as desired by arranging the firing pin associated with the rim-fire primer to engage its primer  
20 slightly behind the firing pin for the centre-fire primer.

As shown in the sequenced drawings of Fig. 6b, the sequence commences with initial contact of the centre-fire primer directing the primer burn to the leading propellant 67 which then ignites resulting in firing of the leading  
25 projectile. This firing forces the trailing projectile nose rearwardly over the mandrel part effecting a seal with the barrel preventing consequent ignition of the second propellant charge 68. This occurs upon the delayed striking of the firing pin associated with the rim fire primer causing  
30 ignition of the propellant and firing of the second projectile.

After both projectiles have been fired, the empty case is mechanically ejected in conventional manner to enable a further cartridge to be loaded from the magazine. Both  
35 projectiles can be fired independently if desired or set to fire automatically in quick succession up to a rate of 45,000

rounds per minute, for example.

Fig. 7a illustrates a further form of double tap ammunition. In this embodiment, the projectiles are spineless, the leading projectile 74 being of conventional  
5 form and being spaced from the trailing projectile 75 by a propellant charge 76. The centre fire primer 77 is supported at the nose of the trailing projectile 75 and is associated with a pin extension 78 extending through a central spine 79 associated with the centre fire primer. In this embodiment,  
10 the firing pin extension 78 seals the central passage within the second projectile 75 after firing has been effected to prevent gas leakage from the second propellant burn.

In a further variation of cased ammunition according to the present invention, shown cutaway in Fig. 7b, ignition of  
15 the propellant associated with the trailing projectile may be achieved through a fuse 81 in the end cap 84 interconnecting the centre fire primer 82 with the rim primer 83 such that the centre fire primer 82 may be utilised to fire the propellant 88 for the first projectile 89 whereafter the  
20 second projectile 85 will fire at a preselected time delay determined by the time required for ignition of the second primer 83 through the fuse 81, igniting the propellant 86. Ignition of the leading propellant, not shown, is through the hollow spine 87.

25 In the cased ammunition embodiment illustrated in Figs. 7c and 7d locating means are utilised to positively locate the projectiles in place in their respective barrels. In the Fig. 7c embodiment retractable wedge shaped rings 58 locate in grooves 59 in the casing and retract into their projectile  
30 grooves 90 upon firing. Alternatively as illustrated in Fig. 7d, the casing 91 may be provided with a internal annular ledge 92 against which the projectile seats.

The electrically fired form of cased ammunition 93 illustrated in FIG. 8 utilises a spine 94 independent of the  
35 projectile and electrically operated primers 95 connected by leads 96 to contacts for completing the firing circuit formed

by the leads and the casing.

Of course the projectile assemblies of the present invention can be bullet shaped as previously illustrated or as illustrated in Fig. 9 they may include a steel spine  
5 portion 97 having a wedge shaped central portion 98 of sufficient size to cause rupturing of the hollow nose part 99 when the latter is slowed by impact with an object. Thus in this embodiment the wedge shaped central portion 98 performs the dual functions of a mandrel for sealing engagement of the  
10 nose part with the barrel during firing and for shattering the nose part upon impact. The nose part and the central portion may be so formed as to cooperate in such manner that, upon striking an object, the energy of the central part is mostly dissipated in an outward splaying and/or shattering of  
15 the nose part, or so that much of the energy of the central portion remains therewith, such as to enable it to penetrate protective vests and the like.

The double tap ammunition of the present invention is provided as a means for increasing the probability of a user  
20 striking the target with one shot. This can be further enhanced in a multi barrel type weapon by, for example, arranging three barrels concentrically about a longitudinal axis and inducing a lateral deflection in the projectiles propelled from the barrels. Suitably this is achieved, as  
25 illustrated in Fig. 10, by providing a barrel assembly 100 having a bleed bypass passage 101 which exits to the muzzle so as to provide a lateral force on the projectile 102 as it exits the muzzle. Suitably the bypass passage 101 is provided with a control valve 103 which may be slid forwards  
30 to close the passage 101 for normal non-deflected operation. The on/off valve 103 is associated with a pistol grip or other means so that a user may quickly change the mode of operation of the weapon. Placing three barrels, or more, concentrically about a longitudinal axis and forming the  
35 bypass passage 101 along their innermost portions, ensures that the combined lateral forces acting on the weapon as a



result of the bypass reactions will total zero.

If desired, the inlet to the bypass passage 101 may be positioned for receipt of gases from a trailing propellant burn, sacrificing some energy of a trailing projectile for  
5 deflecting a leading projectile without loss of energy of the leading projectile.

The barrel assembly of the present invention may be in the form of a replaceable cartridge. For example, a barrel assembly containing projectiles, primers and propellant as  
10 illustrated in Fig. 4 or 5 may constitute a replacement cartridge for a single barrel hand gun. In such an arrangement a hand gun could be provided with a battery operated control circuit in the handpiece controlled by a switch so that an operator could control firing of the weapon  
15 to single round firing or firing of all six rounds at a rapid rate.

Furthermore, by using the barrel assembly of the type illustrated in Figs. 4 and 5, the barrels may be arranged in a honeycomb fashion such as is illustrated diagrammatically  
20 in section in Fig. 11 which shows a pod of two hundred and eighty, 9mm barrels, each containing respective projectile and propellant assemblies occupying a 50mm length of the barrel of which the projectile constitutes about 20mm. Thus for example, a barrel containing twenty projectiles would be  
25 in the order of one and one half metres long, providing a free barrel end space beyond the outermost projectile of about 500mm. Such barrels in a pod of two hundred and eighty, would contain 5,600 projectiles which could be fired in rapid succession or in bursts to suit the situation.  
30 Typically such barrel pods would be formed as disposable units but if desired, the barrel assembly could be adapted to be reloaded with armed sleeves.

Typical weapons which may utilise replacement cartridges include a machine gun which could include an LCD screen  
35 enabling an operator to program the firing sequence required. Single barrel sleeves could also be loaded into a

conventional style revolver having a loading gate containing six chambers, three of which may be in a firing position at any one time, the other three being in a reloading position.

A preferred form of machine gun like weapon 104 according to the present invention, illustrated in Fig. 12, utilises double tap ammunition having a barrel and breech block 105 in somewhat conventional manner, however as illustrated in this embodiment, both the barrel and breech block are provided with respective recoil return springs 106 and 107. The ammunition is arranged to fire both projectiles from each cartridge prior to either the breech block or the barrel assembly reaching its recoil travel limit so that the projectiles are not deflected from their course by the recoil action. In this respect it will be seen that the barrel and breech block 105 recoil together against the action of the recoil spring 107 associated with the barrel which reaches its limits prior to contact between the breech block and its recoil spring 106 such that the breech block may recoil to a greater extent than the barrel assembly, ejecting the empty case in the process and receiving a further round from the magazine for loading into the barrel assembly. This sequence is illustrated in Figs. 13a to 13e.

In weapons in which the recoil would effect the stability of the article or person carrying the weapon, either passive muzzle vents may be used to reduce recoil, such as is illustrated diagrammatically in Figs. 14a and 14b, or an active system may be used may fire blank charges or the like in an opposing direction to reduce the direction to an extent where it has a substantially negligible effect.

The embodiment illustrated in Fig. 15 utilises a fall away sabot assembly 110 to increase the bore diameter of the barrel 111 whereby the length of the propellant space may be minimised enabling more rounds to be carried in a given barrel length. In this embodiment the sabot assembly comprises anvil sectors 112 which form an annular inner ring engaged about the projectile nose 113 and located in

circumferential grooves 114 in the projectile nose. These parts also form a rear flange 115 which extends to the barrel wall to form a rear abutment for outer malleable sectors 116 which form a complementary collar about the anvil sectors

5 112.

It will be seen that the complementary joining faces 117 of the sabot sectors 112 and 116 taper rearwardly and outwardly whereby relative rearward movement of the outer sectors 116 over the inner sectors 112 will force them into  
10 sealing engagement with the barrel as the projectile is propelled through the barrel with propellant thrust on the flange 115 being transmitted to the projectile through its engagement with the grooves 114.

Immediately upon exit from the barrel, the non-  
15 streamlined sabot parts will be free of the barrel constraint holding them together and will subsequently fall away or spin off from the projectile. As the projectile has a diameter which is less than the diameter of the barrel bore, the trailing stem portion 118 can be provided with trailing fins  
20 for enhanced directional stability.

The four barrel embodiment 120 illustrated in Figs. 16 and 17 utilises cased propellant charges 121 in which the propellant is encased in a metal casing 122 which provides the longitudinal stiffness required for maintaining the  
25 spaced projectiles on their operative positions. Each casing 122 has an embedded primer 123 formed with a retractable contact 124, which normally extends outwardly beyond the bore 125, but which may be retracted to enter the bore for movement of the casing 122 to its operative position in the  
30 barrel coincident with a recessed electrical contact 129. Once in position the retractable contact 124, extends to make operative contact with the recessed electrical contact 129.

In this embodiment the wires for the recessed electrical contacts 129 are contained in the central space 126 about  
35 which the barrels 127 are symmetrically arranged. It will also be seen that the front end of the casing 122 is flat and

abuts the flat rear end of the projectile body 128. The intermediate portion of the body 128 is frusto-conical shaped and supports an axially slidable malleable collar 130. A portion of the collar 130 abuts with the trailing end of the casing 122 so that the collar is forced rearwardly and thus expanded radially to provide an effective barrel seal upon application of the rearward force imparted by the leading casing 122 associated with firing of the propellant therein.

Thus a relatively simple and barrel assembly may be formed in which the electrical components are concealed and which and which may be simply loaded and possibly reloaded.

It will of course be realised that the above embodiments have been given only by way of illustrative example of the invention herein and that all such modifications and variations thereto as would be apparent to persons skilled in the art are deemed to fall within the broad scope and ambit of the invention and particularly as is defined in the appended claims.

THE CLAIMS DEFINING THE INVENTION ARE AS FOLLOWS:-

1. A barrel assembly of the type described, wherein:-  
adjacent projectiles are separated from one another and maintained in spaced apart relationship by locating means independent of the projectiles, and  
each projectile includes expandable sealing means for forming an operative seal with the bore of the barrel.
2. A barrel assembly as claimed in claim 1, wherein said locating means is the propellant charge between adjacent projectiles and said sealing means includes a skirt portion of each projectile which expands outwardly when subject to an in-barrel load.
3. A barrel assembly as claimed in claim 2, wherein each propellant charge is in block form.
4. A barrel assembly as claimed in claim 2 or claim 3, wherein said skirt portion extends about an inwardly reducing recess formed in the rear end of a projectile and into which a complementary leading portion of the propellant charge extends and wherein the propellant charge is of such form that rearward movement of the projectile in the barrel will result in radial expansion of the skirt portion about said leading portion.
5. A barrel assembly as claimed in claim 2 or claim 3, and including a projectile having a relatively hard mandrel portion located by said propellant and disposed within said skirt portion for expanding said skirt portion into sealing engagement with the barrel.
6. A barrel assembly as claimed in claim 1, wherein said sealing means and said locating means includes a contractible peripheral locating ring which extends about said projectile and outwardly into annular grooves in the

barrel.

7. A method of electrical ignition for sequentially igniting the propellant charges of a barrel assembly of the type described, including:-

igniting the leading propellant charge by sending an ignition signal through the stacked projectiles, and causing ignition of the leading propellant charge to arm the next propellant charge for actuation by the next ignition signal.

8. A method as claimed in claim 7, wherein all propellant charges inwardly from the end of a loaded barrel are disarmed by the insertion of respective insulating fuses disposed between normally closed electrical contacts.

9. A cased round including:-  
a case adapted for retention in a breech assembly;  
at least two projectiles disposed one behind the other in the case and each seating peripherally with the case, respective propellant charges within the case and behind each projectile, and  
ignition means for igniting the charges in a predetermined sequence.

10. A cased round as claimed in claim 9, wherein the ignition means includes one or more pin fired primers.

11. A cased round as claimed in claim 10, including a pin fired primer which ignites the outermost propellant charge which burns back to ignite the rear charge.

12. A cased round as claimed in claim 10, including a two pin fired primers associated with separate firing pins and each communicating with a respective propellant charge.

13. A cased round as claimed in claim 9, wherein the ignition means includes electrically operated primers and control circuits therefore disposed within the casing.

14. A barrel assembly of the type described including a gas bypass passage adjacent the muzzle which feeds propellant gases back to the barrel in the path of an outgoing projectile.

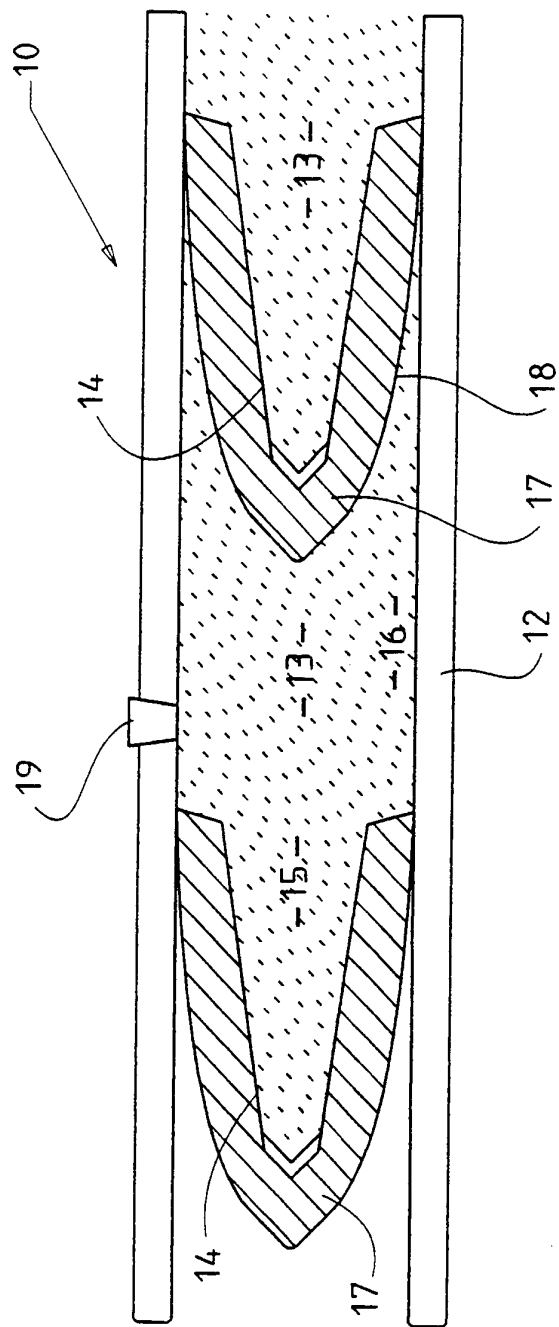

FIG. 1

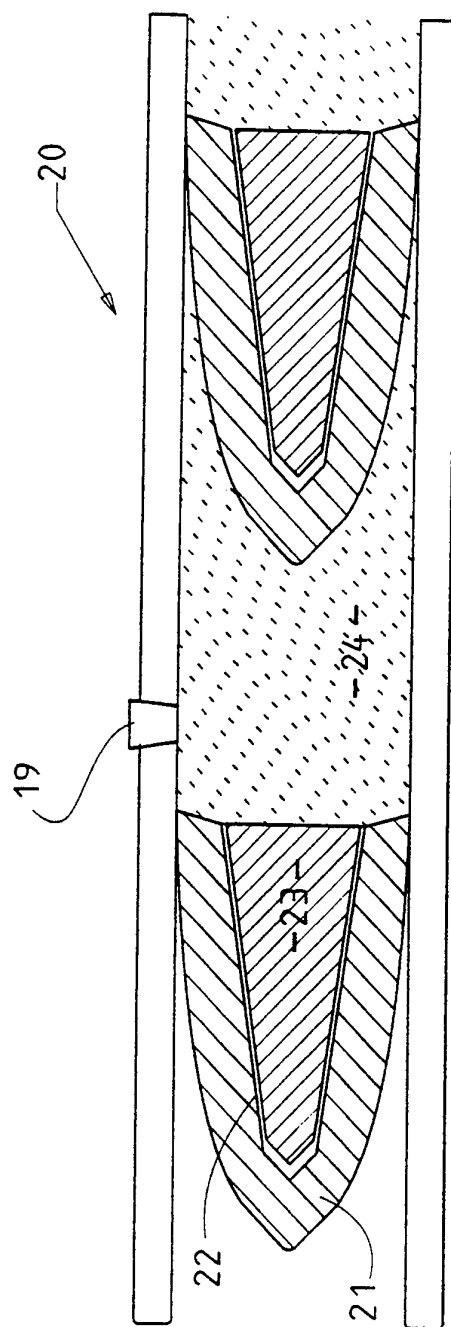

FIG. 2



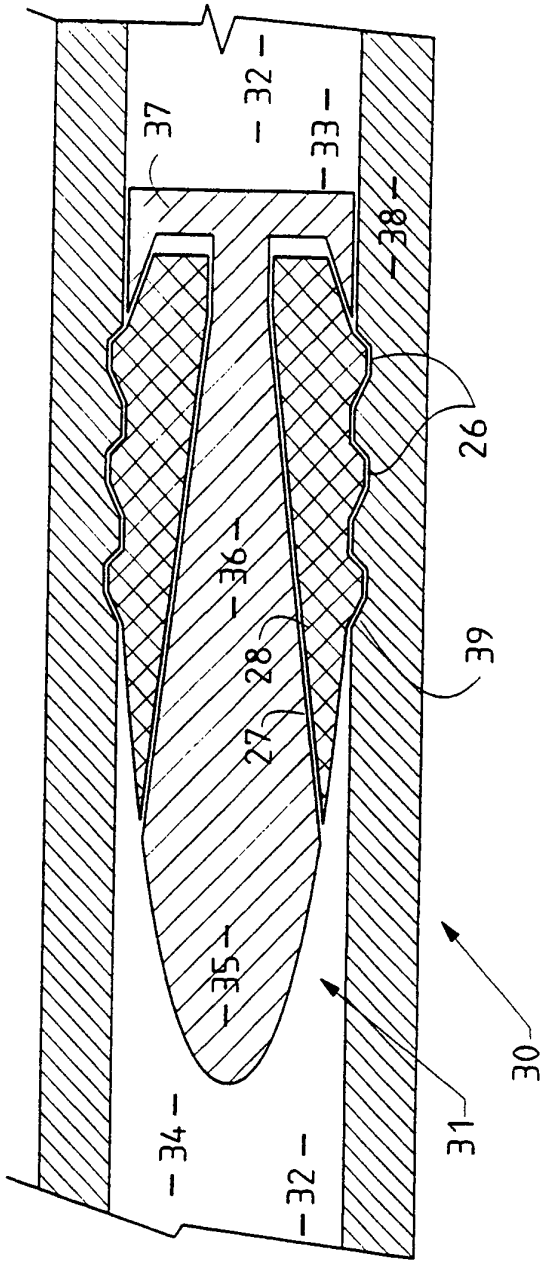

FIG. 3

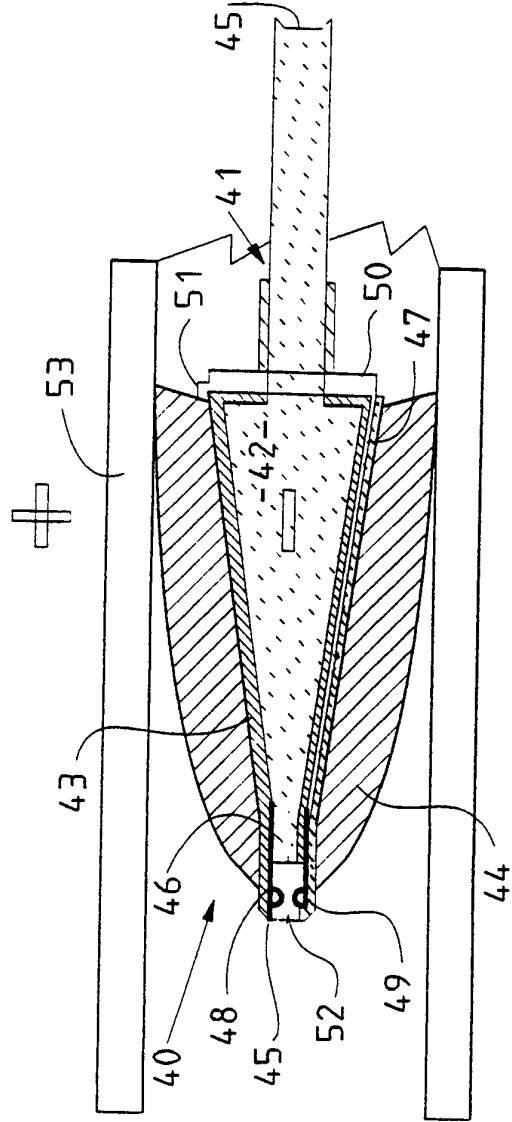

FIG. 4

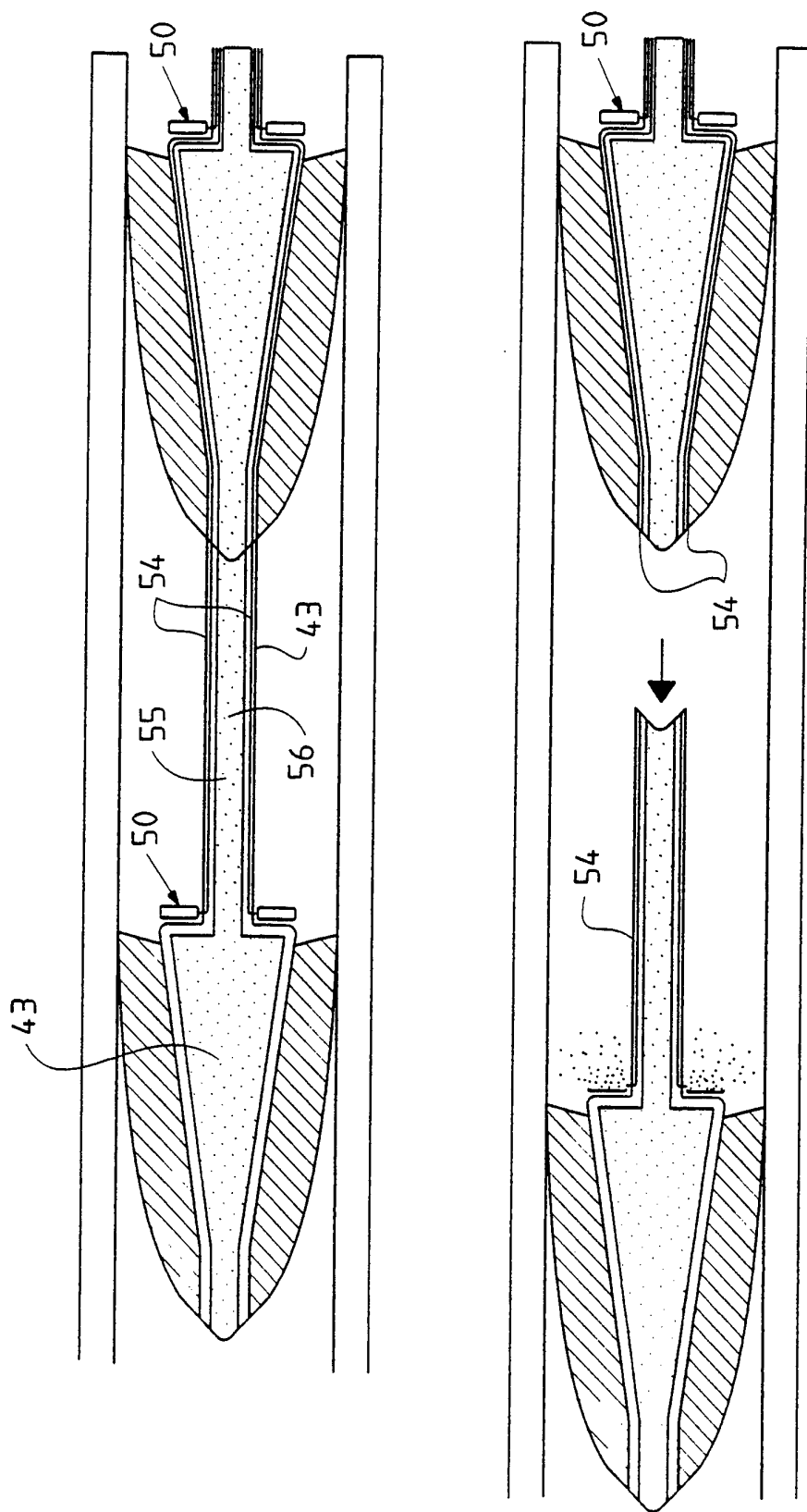

FIG. 5

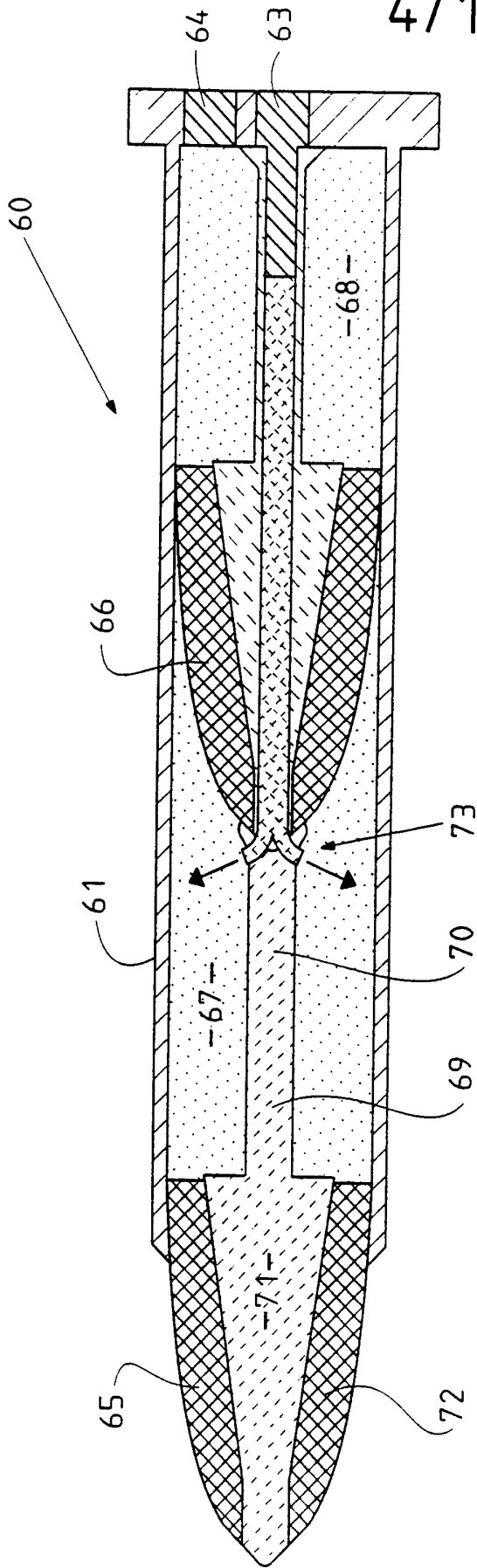

FIG. 6a

5/15

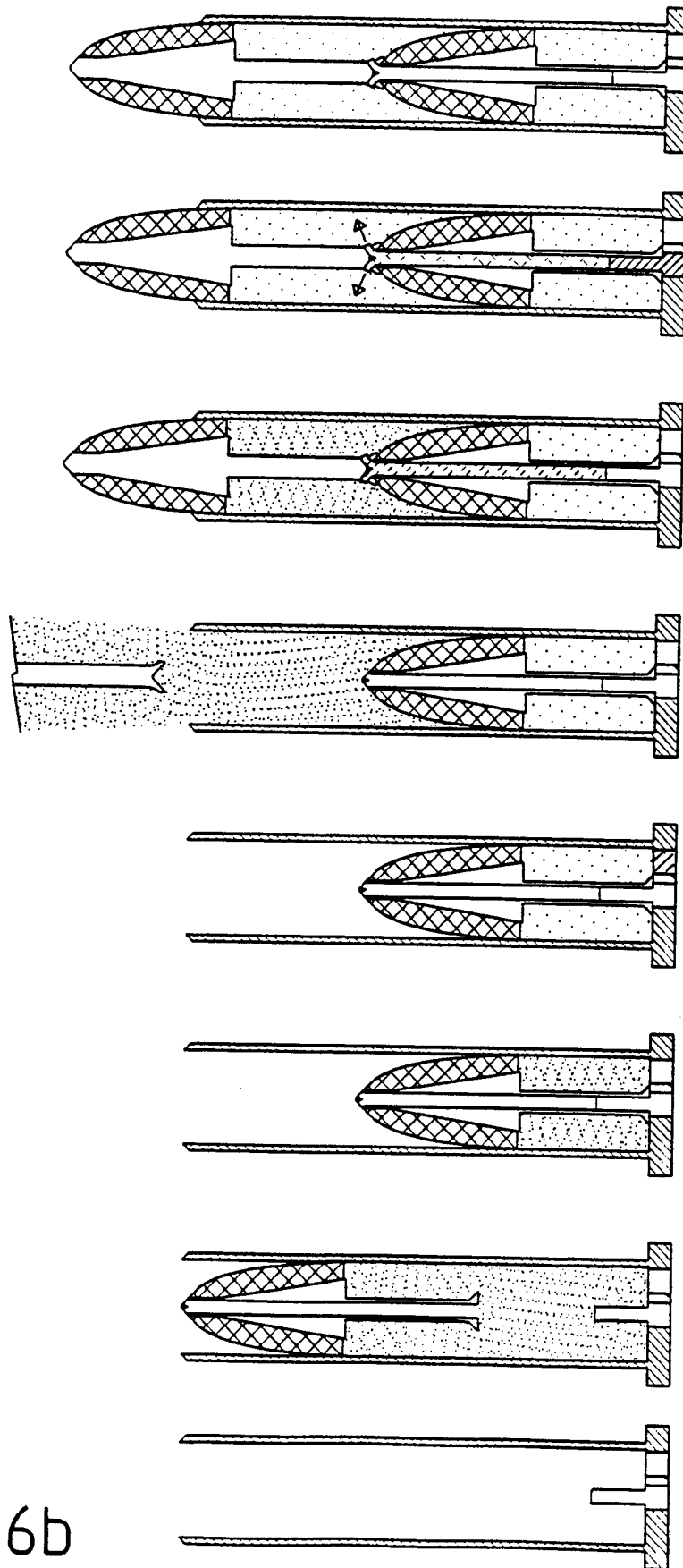

FIG. 6b

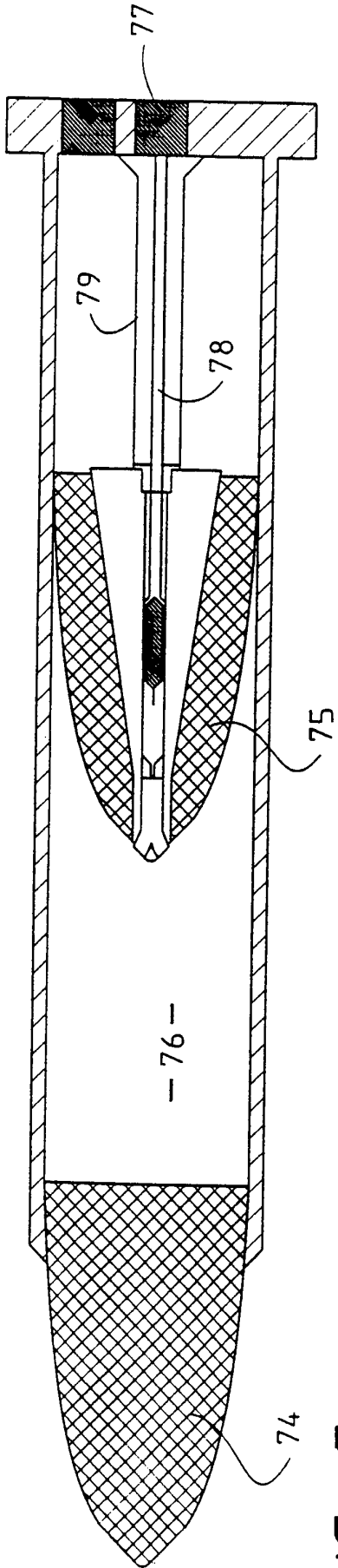

FIG. 7a

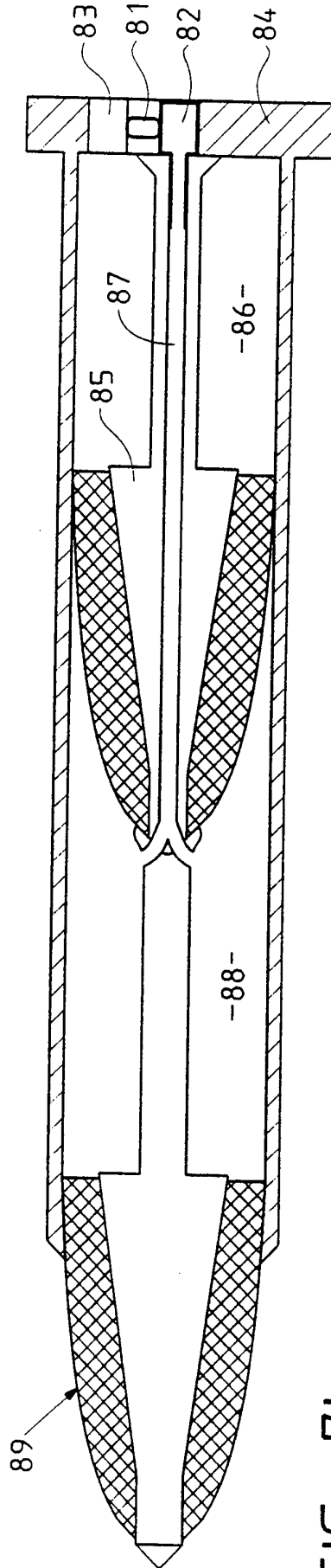

FIG. 7b

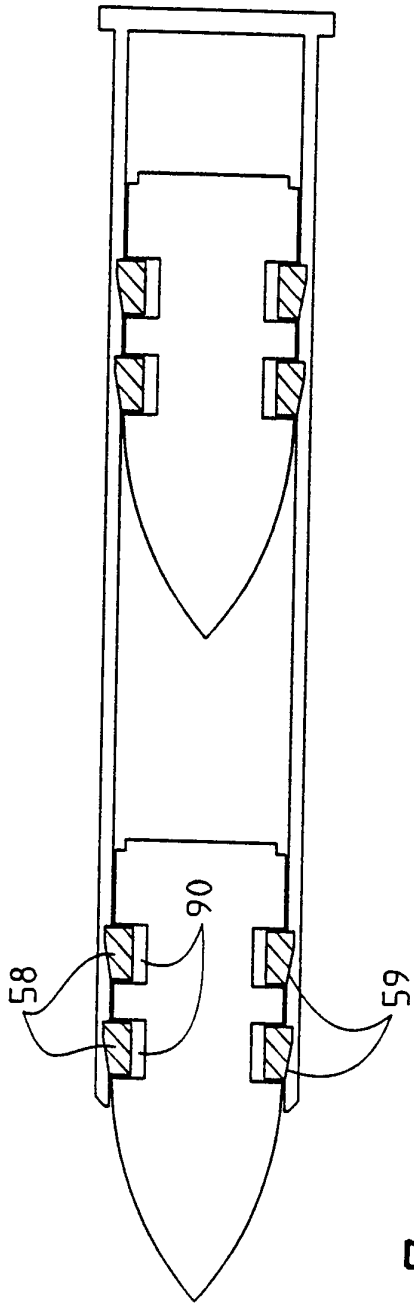

FIG. 7c

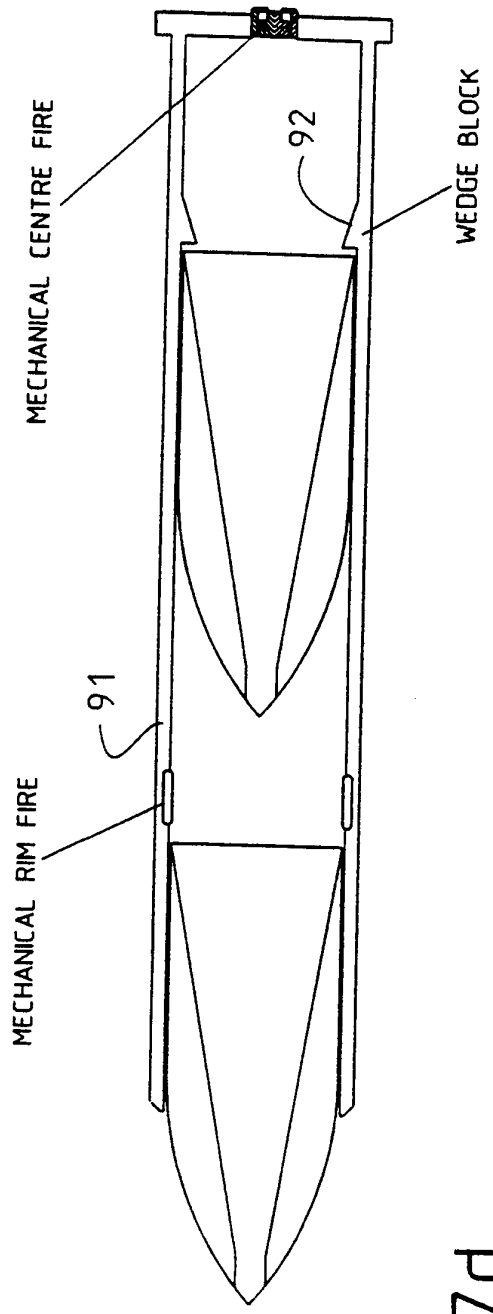

FIG. 7d

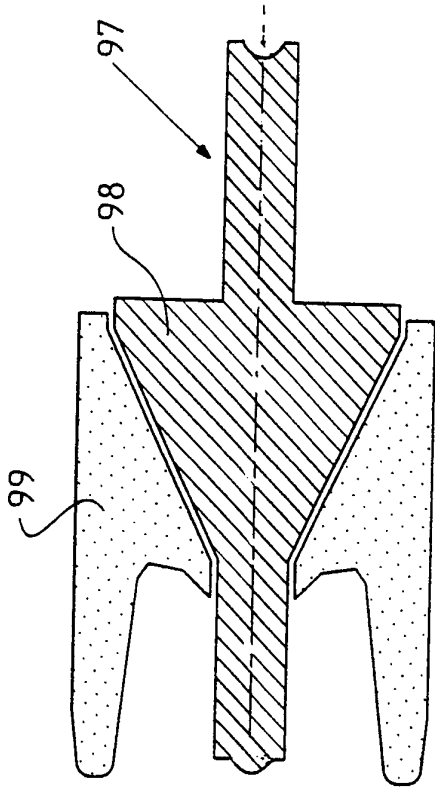

FIG. 9

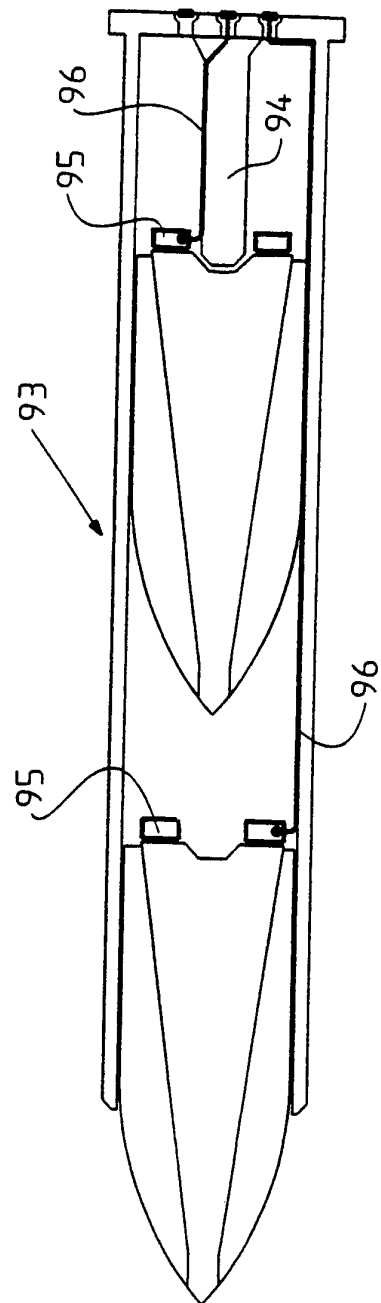

FIG. 8

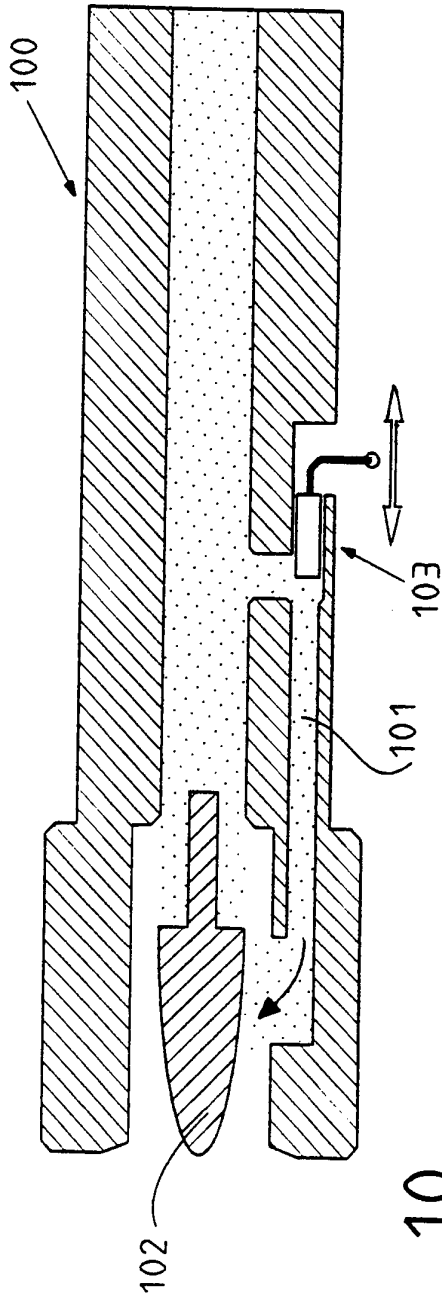

FIG. 10

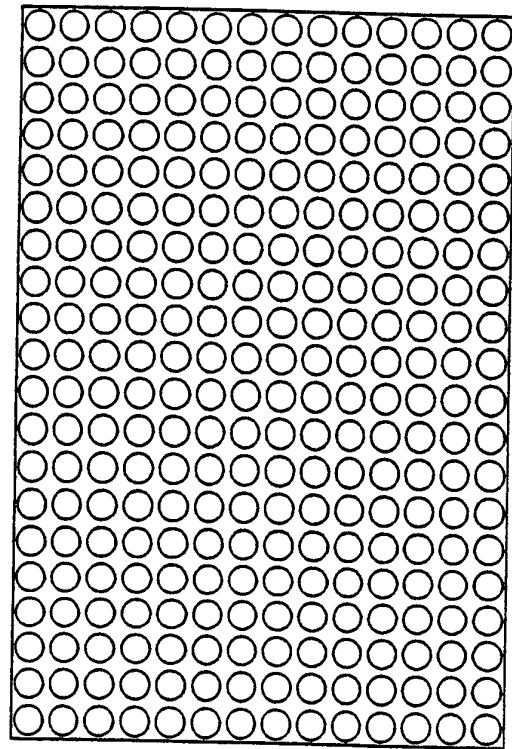

FIG. 11



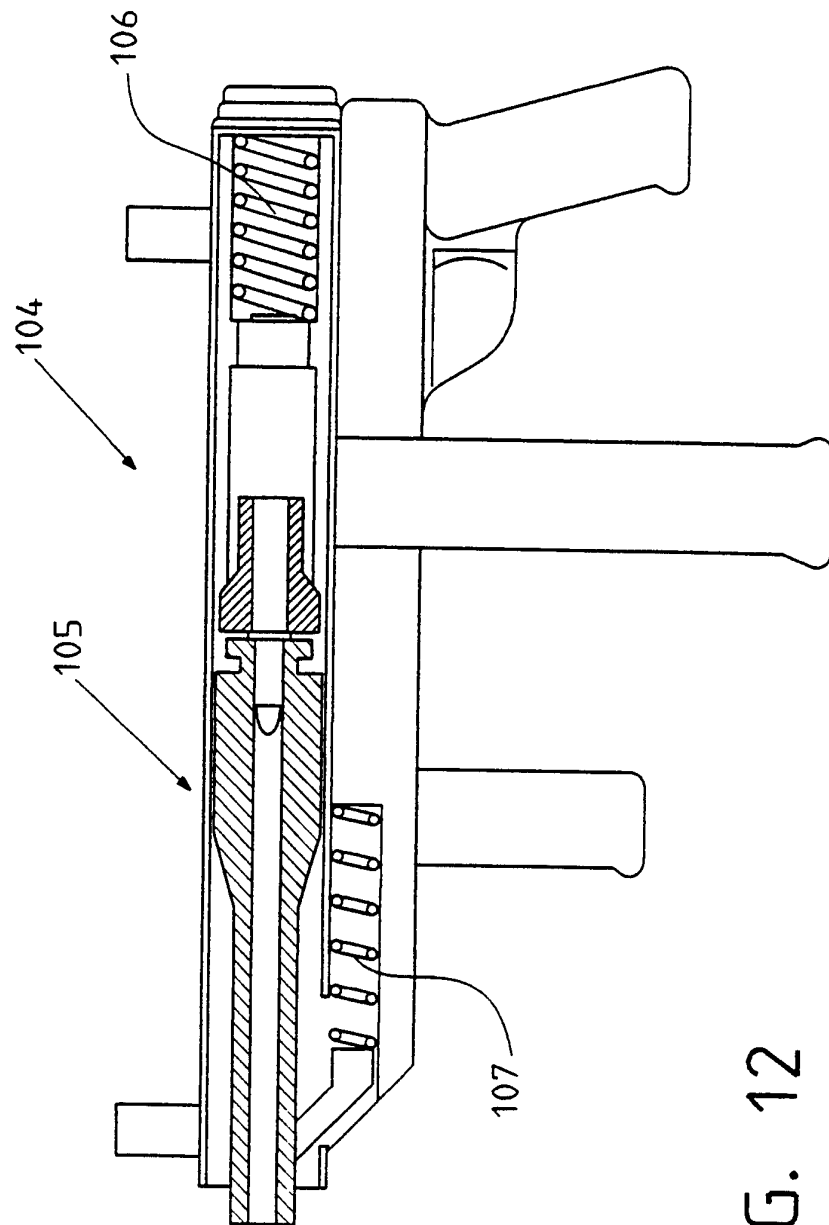

FIG. 12

11/15

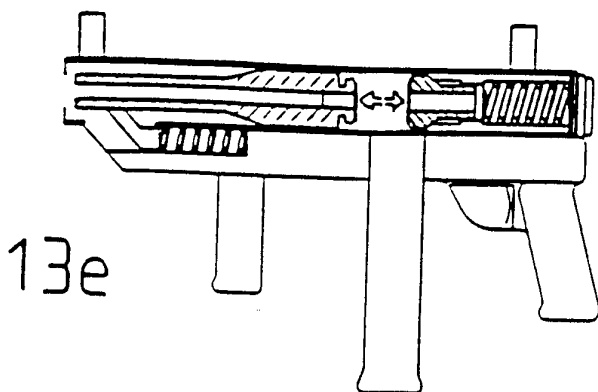
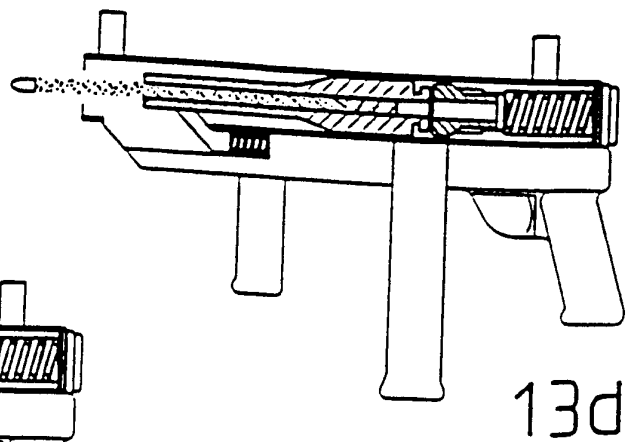
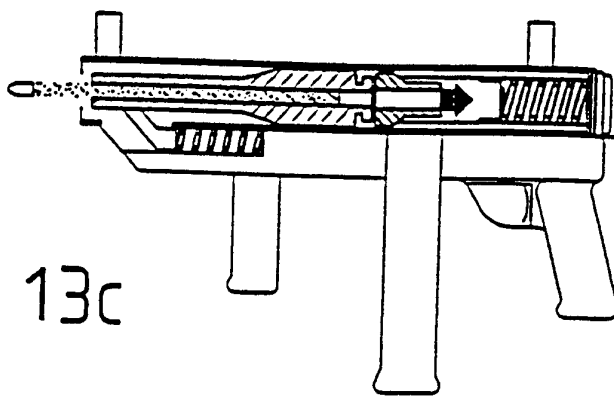
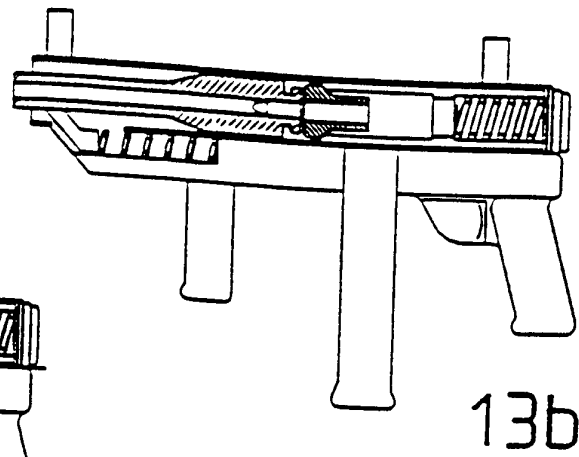
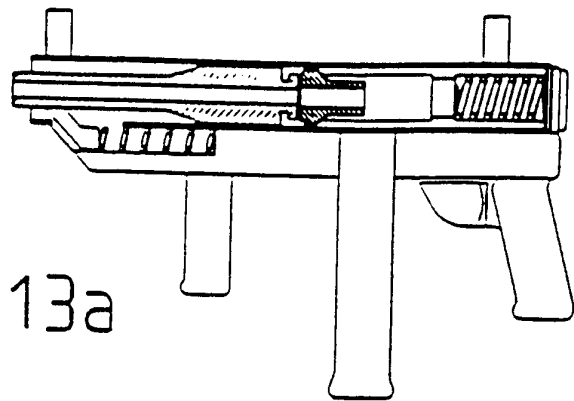

FIG. 13

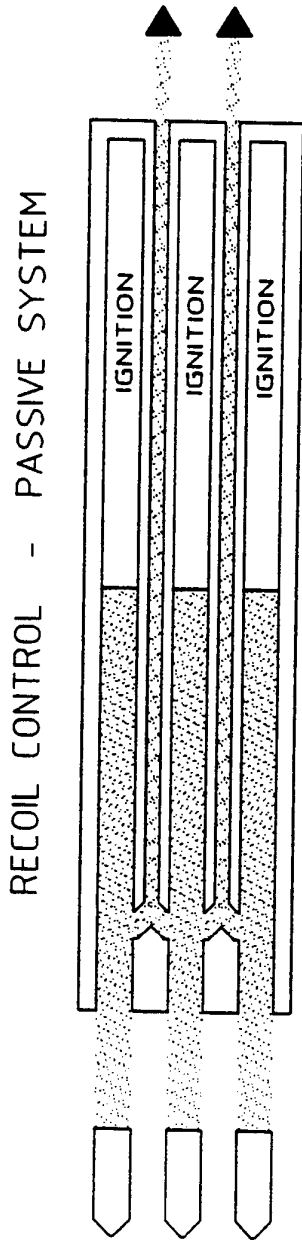

FIG. 14a

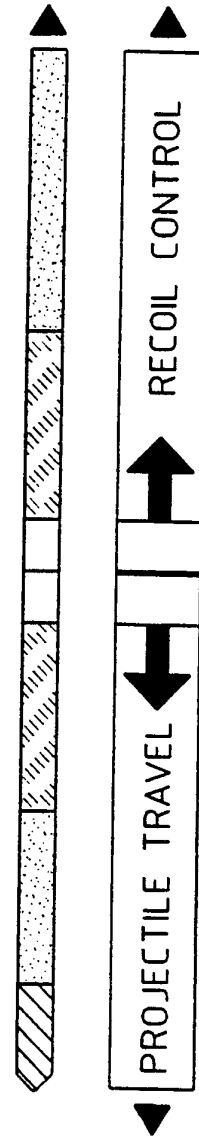

FIG. 14b

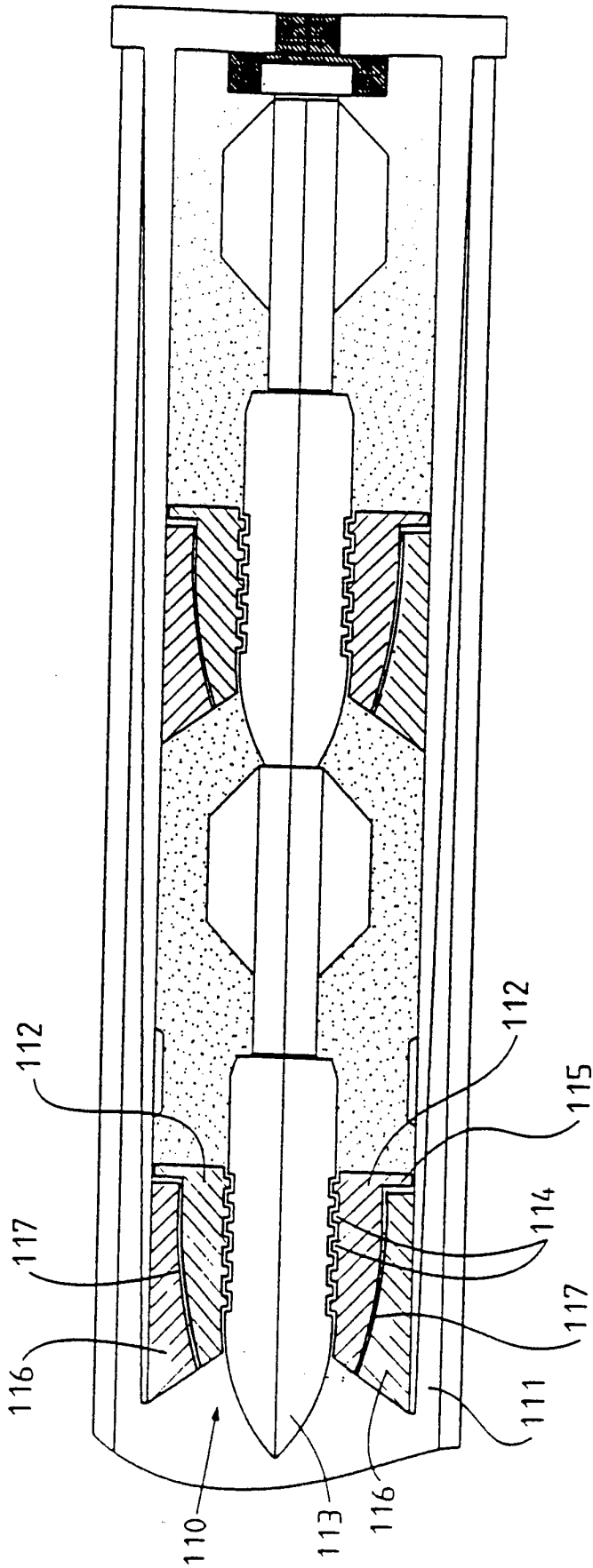

FIG. 15



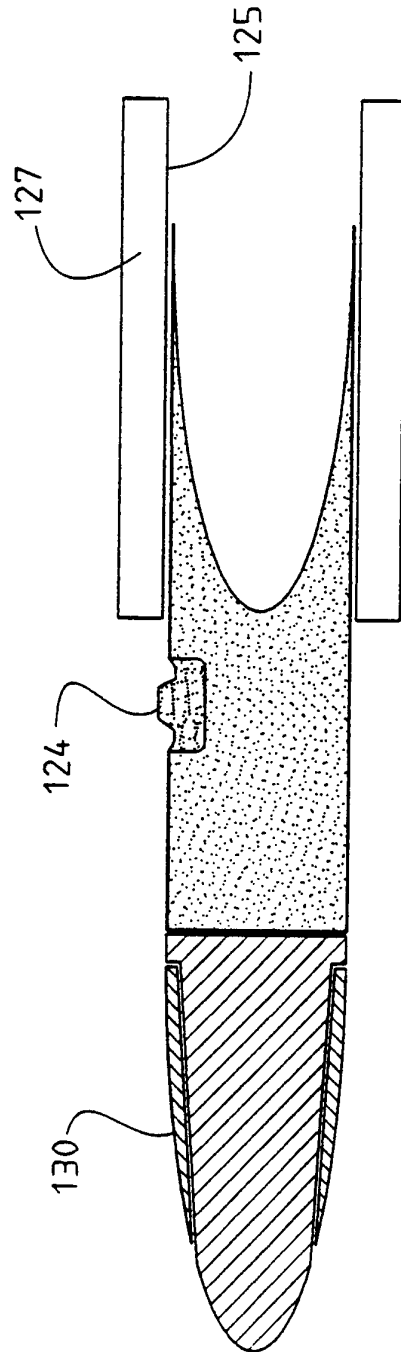

FIG. 17

**INTERNATIONAL SEARCH REPORT**

International Application No.  
PCT/AU 96/00459

<b>A. CLASSIFICATION OF SUBJECT MATTER</b>		
Int Cl <sup>0</sup> : F41A 21/00, 21/06, 21/28		
According to International Patent Classification (IPC) or to both national classification and IPC		
<b>B. FIELDS SEARCHED</b>		
Minimum documentation searched (classification system followed by classification symbols) IPC F41A 21/00, 21/06, 21/28; F41C 3/00; F41F 1/08, 1/00		
Documentation searched other than minimum documentation to the extent that such documents are included in the fields searched AU: IPC as above		
Electronic data base consulted during the international search (name of data base and, where practicable, search terms used) WPAT, JAPIO		
<b>C. DOCUMENTS CONSIDERED TO BE RELEVANT</b>		
Category*	Citation of document, with indication, where appropriate, of the relevant passages	Relevant to claim No.
X	WO 9420809 A (O'DWYER) 15 September 1994 see abstract, figures 1, 4-11 and page 10 lines 1-13	1-5, 7
A	DE 314073 A (DELLING) 9 August 1919 page 1 lines 16-60	
A	FR 1537857 A (SOCIETE D'ETUDE DE LA PROPULSION PAR REACTON) 22 July 1968 page 2 lines 19-32	
<input checked="" type="checkbox"/> Further documents are listed in the continuation of Box C <input checked="" type="checkbox"/> See patent family annex		
* Special categories of cited documents: "A" document defining the general state of the art which is not considered to be of particular relevance "E" earlier document but published on or after the international filing date "L" document which may throw doubts on priority claim(s) or which is cited to establish the publication date of another citation or other special reason (as specified) "O" document referring to an oral disclosure, use, exhibition or other means "P" document published prior to the international filing date but later than the priority date claimed "T" later document published after the international filing date or priority date and not in conflict with the application but cited to understand the principle or theory underlying the invention "X" document of particular relevance; the claimed invention cannot be considered novel or cannot be considered to involve an inventive step when the document is taken alone "Y" document of particular relevance; the claimed invention cannot be considered to involve an inventive step when the document is combined with one or more other such documents, such combination being obvious to a person skilled in the art "&" document member of the same patent family		
Date of the actual completion of the international search 23 September 1996		Date of mailing of the international search report 2 OCT 1996
Name and mailing address of the ISA/AU AUSTRALIAN INDUSTRIAL PROPERTY ORGANISATION PO BOX 200 WODEN ACT 2606 AUSTRALIA Facsimile No.: (06) 285 3929		Authorized officer M S HAYNES Telephone No.: (06) 283 2170

**INTERNATIONAL SEARCH REPORT**

International Application No.  
PCT/AU 96/00459

**C (Continuation) DOCUMENTS CONSIDERED TO BE RELEVANT**

Category*	Citation of document, with indication, where appropriate, of the relevant passages	Relevant to claim No.
A	GB 2161908 A (GUTHRIE) 22 January 1986 see abstract	
A	FR 2045265 A (SOCIETE ARAMA SA) 26 February 1971 see claim 1	
A	US 3855899 A (BILLOTTET et al.) 24 December 1974 see abstract	



# INTERNATIONAL SEARCH REPORT

International Application No.  
PCT/AU 96/00459

## Box I Observations where certain claims were found unsearchable (Continuation of item 1 of first sheet)

This International Search Report has not been established in respect of certain claims under Article 17(2)(a) for the following reasons:

1.  Claims Nos.:  
because they relate to subject matter not required to be searched by this Authority, namely:
  
2.  Claims Nos.:  
because they relate to parts of the international application that do not comply with the prescribed requirements to such an extent that no meaningful international search can be carried out, specifically:
  
3.  Claims Nos.:  
because they are dependent claims and are not drafted in accordance with the second and third sentences of Rule 6.4(a)

## Box II Observations where unity of invention is lacking (Continuation of item 2 of first sheet)

This International Searching Authority found multiple inventions in this international application, as follows:

Claims 1-6 define a barrel assembly with adjacent projectiles separated by locating means independent of the projectiles.

Claims 7-8 define a method of electrical ignition.

Claims 9-13 define a cased round.

Claim 14 defines a barrel assembly with a gas bypass passage as reasoned in the extra sheet.

1.  As all required additional search fees were timely paid by the applicant, this international search report covers all searchable claims
2.  As all searchable claims could be searched without effort justifying an additional fee, this Authority did not invite payment of any additional fee.
3.  As only some of the required additional search fees were timely paid by the applicant, this international search report covers only those claims for which fees were paid, specifically claims Nos.:
  
4.  No required additional search fees were timely paid by the applicant. Consequently, this international search report is restricted to the invention first mentioned in the claims; it is covered by claims Nos.:

- Remark on Protest
- The additional search fees were accompanied by the applicant's protest.
- No protest accompanied the payment of additional search fees.

## Box II (continued)

The international application does not comply with the requirements of unity of invention because it does not relate to one invention or to a group of inventions so linked as to form a single general inventive concept. In coming to this conclusion the International Searching Authority has found that there are four inventions:

Claims 1-6 are directed to a barrel assembly with adjacent projectiles which are separated by locating means independent of the projectiles. The projectiles also have expandable sealing means.

Claims 7-8 are directed to a method of electrical ignition of a barrel assembly.

Claims 9-13 are directed to a cased round.

Claim 14 is directed to a barrel assembly with a gas bypass passage.

Since the above-mentioned group of claims do not share the same technical features a "technical relationship" between the invention, as defined in PCT Rule 13.2 does not exist. Accordingly the international application does not relate to one invention or to a single inventive concept.

**INTERNATIONAL SEARCH REPORT**

International Application No.

## Information on patent family members

PCT/AU 96/00459

This Annex lists the known "A" publication level patent family members relating to the patent documents cited in the above-mentioned international search report. The Australian Patent Office is in no way liable for these particulars which are merely given for the purpose of information.

Patent Document Cited in Search Report		Patent Family Member					
WO	9420809	AU	62790/94	BR	9406382	CA	2157882
		CN	1120863	EP	693172	HU	9502653
FR	1537857	NIL					
GB	2161908	NIL					
FR	2045265	NIL					
US	3855899	ZA	7201949	BE	781723	CA	958574
		CH	565361	DE	2215398	ES	401471
		FR	2133034	GB	1383074	IT	960319
		NL	7204508	NO	142492		
END OF ANNEX							