

(19) World Intellectual Property
Organization
International Bureau



(43) International Publication Date
20 October 2005 (20.10.2005)

PCT

(10) International Publication Number
WO 2005/097340 A1

(51) International Patent Classification⁷: **B05B 7/04**,
B67D 5/16, B29C 44/34

(CA). GAWNE, Brent, Robert [CA/CA]; 9389 Oldfield
Line, Tupperville, Ontario N0P 2M0 (CA).

(21) International Application Number:
PCT/IB2005/000903

(81) Designated States (unless otherwise indicated, for every
kind of national protection available): AE, AG, AL, AM,
AT, AU, AZ, BA, BB, BG, BR, BW, BY, BZ, CA, CH, CN,
CO, CR, CU, CZ, DE, DK, DM, DZ, EC, EE, EG, ES, FI,
GB, GD, GE, GH, GM, HR, HU, ID, IL, IN, IS, JP, KE,
KG, KM, KP, KR, KZ, LC, LK, LR, LS, LT, LU, LV, MA,
MD, MG, MK, MN, MW, MX, MZ, NA, NI, NO, NZ, OM,
PG, PH, PL, PT, RO, RU, SC, SD, SE, SG, SK, SL, SM, SY,
TJ, TM, TN, TR, TT, TZ, UA, UG, US, UZ, VC, VN, YU,
ZA, ZM, ZW.

(22) International Filing Date: 6 April 2005 (06.04.2005)

(25) Filing Language: English

(26) Publication Language: English

(30) Priority Data:
10/818,576 6 April 2004 (06.04.2004) US

(84) Designated States (unless otherwise indicated, for every
kind of regional protection available): ARIPO (BW, GH,
GM, KE, LS, MW, MZ, NA, SD, SL, SZ, TZ, UG, ZM,
ZW), Eurasian (AM, AZ, BY, KG, KZ, MD, RU, TJ, TM),
European (AT, BE, BG, CH, CY, CZ, DE, DK, EE, ES, FI,
FR, GB, GR, HU, IE, IS, IT, LT, LU, MC, NL, PL, PT, RO,
SE, SI, SK, TR), OAPI (BF, BJ, CF, CG, CI, CM, GA, GN,
GQ, GW, ML, MR, NE, SN, TD, TG).

(71) Applicant (for all designated States except US): AD-
VANCED CONTROLS AND ENGINEERING
[CA/CA]; 540 Park Avenue East, Chatham, Ontario
N7M 5J4 (CA).

(72) Inventors; and

(75) Inventors/Applicants (for US only): DIDONATO, Sante
[CA/CA]; 22761 Creek Road, Chatham, Ontario N7M 5J3

Published:
— with international search report

[Continued on next page]

(54) Title: URETHANE SPRAY GUN ASSEMBLY

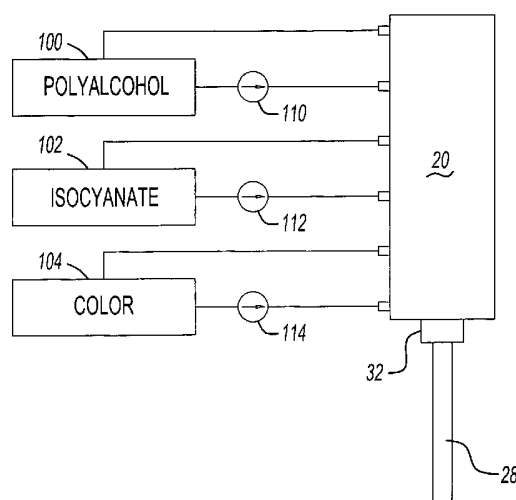

(57) Abstract: A spray urethane gun assembly having a main body with a bore and a mixing chamber. An elongated spool is longitudinally, slidably mounted in the main body bore and movable between an extended position and a retracted position by an actuator. A first and a second inlet port are formed in the main body and a first and second outlet port are also formed in the main body. A first axially extending fluid passageway is formed in the spool and this first fluid passageway fluidly connects the first inlet port with the first outlet port when the spool is in one of the retracted or extended position, and fluidly connects the first inlet port with the mixing chamber when the spool is in the other of the retracted or extended position. A second axially extending passageway is formed in the spool and this second fluid passageway fluidly connects the second inlet port with the second outlet port when the spool is in one of its retracted or extended position, and fluidly connects the second inlet port with the mixing chamber when the spool is in the other of its retracted or extended position. A dispensing port formed in the main body is open to the mixing chamber for dispensing the fluid mixture within the mixing chamber.

WO 2005/097340 A1



-
- *before the expiration of the time limit for amending the claims and to be republished in the event of receipt of amendments*
- For two-letter codes and other abbreviations, refer to the "Guidance Notes on Codes and Abbreviations" appearing at the beginning of each regular issue of the PCT Gazette.*

URETHANE SPRAY GUN ASSEMBLY

BACKGROUND OF THE INVENTION

RELATED APPLICATIONS

The present application claims the benefit U.S. Patent Application Serial No. 10/818,576 filed April 6, 2004, which is incorporated herein by reference.

5 FIELD OF THE INVENTION

The present invention relates to spray gun assemblies for manufacturing polyurethane skin components.

DESCRIPTION OF RELATED ART

Guns for spraying urethane are used in many different manufacturing applications, e.g. such as the manufacture of interior compartment components for automotive vehicles. These spray guns, when actuated, form a mixture of polyol and isocyanate and dispense the mixture through conventional dispensing means, such as a needle valve operated dispensing gun. In the well-known fashion, polyol and isocyanate, when combined, form a foam which rapidly cures into a flexible skin.

15 These previously known spray guns for urethane typically include a main body having a first port fluidly connected with a pressurized source of polyol, a second port fluidly connected with a pressurized source of isocyanate, and a third port for solvent. A first needle valve is fluidly connected in series with the first fluid port while, similarly, a second needle valve is fluidly connected in series with the second fluid port. These needle valves are movable between
20 an open and a closed position. In their closed position, the needle valves prevent fluid flow of

either the polyol or the isocyanate through the first and second ports, respectively. Conversely, when the needle valves are moved to their open positions, fluid flow of both the polyol as well as the isocyanate to the dispensing wand occurs.

5 These previously known guns for spraying urethane, however, have not proven wholly satisfactorily in use. One disadvantage of these previously known urethane spray guns is that, when the needle valves are moved to their open position, the polyol and isocyanate are directly fluidly connected with the dispensing wand. In some cases, inadequate intermixing of the polyol and the isocyanate results which, in turn, results in inadequate urethane foam production.

SUMMARY OF THE PRESENT INVENTION

10 The present invention provides a spray gun for urethane which overcomes all of the above-mentioned disadvantages of the previously known devices.

In brief, the urethane spray gun of the present invention comprises a main body having a bore and a mixing chamber at one end of the body. An elongated spool is longitudinally slidably mounted within the bore in the main body and is movable between an extended and a retracted
15 position. An actuator connected to the spool moves the spool between its retracted and its extended position and, preferably, the actuator is pneumatically or hydraulically operated.

A first inlet port and a second inlet port are formed on the main body. Similarly, a first outlet port and second outlet port are also formed on the main body.

In a first embodiment of the invention, a first axially extending fluid passageway is
20 formed on the spool and this first fluid passageway fluidly connects the first inlet port with the first outlet port when the spool is in its retracted position. Conversely, the first inlet passageway fluidly connects the first inlet port with the mixing chamber when the spool is in its extended position.

A second axially extending fluid passageway is also formed on the spool. The second fluid passageway fluidly connects the second inlet port with the second outlet port when the spool is in its retracted position. When the spool is moved to its extended position, the second fluid passageway fluidly connects the second inlet port with the mixing chamber in the main
5 body.

A dispensing port is also formed on the housing and open to the mixing chamber. Any conventional means, such as a wand having a throughbore, is fluidly connected to the dispensing chamber so that the fluid in the mixing chamber flows out through the wand.

In use, the first fluid port is fluidly connected to a source of pressurized polyol while the
10 first outlet port is fluidly connected to the source of polyol at a lower pressure. Similarly, a pressurized source of isocyanate is fluidly connected to the second inlet port while the second outlet port is fluidly connected to the source of isocyanate at a lower pressure.

Consequently, when the spool is in its retracted position, the polyol circulates through the first inlet, first passageway, and first outlet while, simultaneously, the isocyanate circulates
15 through the second inlet, second passageway and second outlet back to the source of isocyanate. Conversely, when the spool is moved to its extended position, the first and second spool passageways respectively fluidly connect the pressurized source of polyol and the pressurized source of isocyanate to the mixing chamber. The polyol and isocyanate pre-mix within the mixing chamber and the resulting mixture is then dispensed through the dispensing wand.

20 Optionally, the main body includes a third inlet port and a third outlet port which cooperate with a third fluid passageway formed in the spool. A pressurized source of a colorant is then fluidly connected to the third inlet port while the third outlet port is fluidly connected to the colorant source at a lower pressure.

Since the polyol, isocyanate and, optionally, colorant continuously circulate through the main body of the spray gun between dispensing operations, the spray gun is maintained at the temperature of the polyol and isocyanate thus eliminating, or at least minimizing, the possibility of thermal shock at the initiation of a dispensing operation. Similarly, since the polyol, isocyanate, and, optionally, colorant are pre-mixed in the mixing chamber prior to dispensing through the wand, a uniform mix of the polyol, isocyanate, and, optionally, colorant is ensured.

In a second embodiment of the invention, the movement of the spool is reversed. Consequently, dispensing occurs when the spool is moved to a retracted position while dispensing occurs when the spool is moved to an extended position.

10

BRIEF DESCRIPTION OF THE DRAWING

A better understanding of the present invention will be had upon reference to the following detailed description, when read in conjunction with the accompanying drawing, wherein like reference characters refer to like parts throughout the several views, and in which:

FIG. 1 is a plan view of a preferred embodiment of the invention;

15

FIG. 2 is a plan view similar to FIG. 1, but at a different rotational angle;

FIG. 3A is a sectional view taken along line 3A-3A in FIG. 1 and showing the spool in a retracted position;

FIG. 3B is a sectional view similar to FIG. 3A, but showing the spool in an extended position;

20

FIG. 4 is a sectional view taken along line 4-4 in FIG. 1 and enlarged for clarity;

FIG. 5 is a sectional view taken along line 5-5 in FIG. 1 and enlarged for clarity;

FIG. 6 is a diagrammatic view illustrating the present invention as used in a system;

FIG. 7 is a view similar to FIG. 3B, but illustrates a second preferred embodiment of the invention; and

FIG. 8 is a view similar to FIG. 3A, but illustrates the second preferred embodiment of the invention.

5
DETAILED DESCRIPTION OF A PREFERRED
EMBODIMENT OF THE PRESENT INVENTION

With reference first to FIGS. 1 and 3A, a preferred embodiment of the spray gun assembly 20 is shown and comprises an elongated and generally cylindrical main body 22. A mixing chamber 24 is formed within the main body 22 at one end of the main body 22. A
10 dispensing port 26 on the main body 22 is fluidly open to the mixing chamber 24.

A dispensing wand 28 having a throughbore 30 has one end detachably connected to the port 26 so that the passageway 30 is fluidly connected in series with the mixing chamber 24. Although any conventional means may be used to attach the wand 28 to the dispensing port 26, preferably a threaded connection 32 between the main body 22 and the wand 28 detachably
15 connects the wand 28 to the main body 22 thus enabling different wands 28 to be used with the main body 22.

With reference now particularly to FIG. 3A, an elongated axially extending bore 34 is formed through the main body 22 so that one end of the bore 22 is open to the mixing chamber 24. An elongated spool 36 is axially slidably mounted within the bore 34 and is movable
20 between a retracted position, illustrated in FIG. 3A, and an extended position, illustrated in FIG. 3B.

Although any conventional means may be used to displace the spool 36 between its extended position and its retracted position, in the preferred embodiment, the main body includes

a piston chamber 38 at the end of the main body 22 opposite from the mixing chamber 24. A piston 40 is slidably disposed within the piston chamber 38 and is attached to the spool 36 so that the piston 40 and spool 36 move in unison with each other. A pair of actuator ports 42 and 44 formed in the main body 22 are fluidly connected with a pneumatic system 46 (illustrated only
5 diagrammatically) which controls the pressurization at the pneumatic ports 42 and 44 and thus the position of the piston 40 within the piston chamber 38.

With reference now particularly to FIGS. 1, 2 and 4, a first inlet port 50, a second inlet port 52 and, optionally, a third inlet port 54 are formed in the main body 22 so that the first inlet port 50, second inlet port 52 and third inlet port 54 are fluidly connected to the bore 34 in the
10 main body 22. Similarly, as shown in FIG. 5, a first outlet port 56, second outlet port 58 and, optionally, third outlet port 60 are also formed in the main body 22. Each of the outlet ports 56, 58 and 60 are fluidly connected to the main body bore 34 such that the first, second and third outlet ports 56, 58 and 60 are axially spaced from the first, second and third inlet ports 50, 52 and 54, respectively.

With reference now particularly to FIGS. 3A and 4, a first axially extending passageway 70 in the spool 36 fluidly connects the first inlet port 50 with the first outlet port 56 when the spool 36 is in its retracted position (FIG. 3A). Similarly, a second axially extending passageway 72 (FIG. 4) and third axially extending passageway 74 in the spool 36 fluidly connect the second inlet port 52 with the second outlet port 58 and the third inlet port 54 with the third outlet port
20 60, respectively, when the spool 36 is in its retracted position.

Conversely, when the spool 36 is moved to its extended position, illustrated in FIG. 3B, the first, second and third spool passageways 70, 72 and 74, respectively, fluidly connect the first, second and third inlet ports, 50, 52 and 54, respectively, to the mixing chamber 24.

Preferably and with reference to FIG. 4, a first metering valve 80 is fluidly connected in series between the first port 50 and the bore 34 in the main body 22. Similarly, a second metering valve 82 is fluidly connected in series between the second inlet port and the main body bore 34 while a third metering valve 84 is fluidly connected in series between the third inlet port
5 54 and the main body bore 34. Each metering valve 80, 82 and 84 is conventional in construction and variably restricts the fluid flow through its associated inlet port.

With reference now to FIG. 6, a spray urethane system utilizing the gun 20 of the present invention is illustrated diagrammatically and includes a source 100 of polyol, a source 102 of isocyanate, and, optionally, a source 104 of a colorant. The polyol from the source 100 is
10 pressurized by a pump 110 having its outlet fluidly connected with the first inlet port 50. The first outlet port 56 is then fluidly connected the source of polyol upstream from the pump 110.

Similarly, the source of isocyanate is pressurized by a pump 112 having its outlet connected to the second inlet port 52. The second outlet port 58 is then fluidly connected to the source 102 of isocyanate upstream from the pump 112.

15 Similarly, a pump 114 has its inlet connected to the source of colorant 104 and its outlet connected to the third inlet port 54. The third outlet port 60 is then fluidly connected to the source 104 of colorant upstream from the pump 114.

In operation, and assuming that the spool 36 is in its retracted position (FIG. 3A), the pump 110 continuously circulates polyol from the source 100 from the first inlet port 50, through
20 the first spool passageway 70 and back to the polyol source 100. Similarly, the pump 112 continuously circulates the isocyanate through the second inlet port 52, second spool passageway 72 and second outlet port 58 back to the source 102 of isocyanate. Likewise, the pump 114

continuously circulates the colorant from the source 104 through the third inlet port 56, third spool passageway 74 and third outlet 60 back to the source of colorant 104.

Conversely, when the spool 36 is moved to its extended position (FIG. 3B), the first, second and third spool passageways 70, 72 and 74, respectively, fluidly connect the first, second and third inlet ports 50, 52 and 54 to the mixing chamber 24. The mixing chamber 24 thus ensures a complete mixture of the polyol, isocyanate, and, optionally, the colorant prior to the dispensing of the mixture from the mixing chamber 24 out through the dispensing wand 28.

By continuously re-circulating the polyol, isocyanate and colorant through their respective inlet and outlet ports on the main body 22, the spool 36 and main body 22, at least adjacent the mixing chamber 24, are maintained at substantially the same temperature as the polyol, isocyanate and colorant. In doing so, thermal shock of the mixture upon activation of the spray gun is effectively eliminated.

With reference now to FIGS. 7 and 8, a second preferred embodiment of a spray gun 120 of the present invention is shown. The spray gun 120 includes an elongated main body 122 having a mixing chamber 124 formed at one end. A dispensing wand 128 is connected to one end of the main body 122 and is fluidly connected to the dispensing wand through a port 126.

A spool 136 is mounted within a bore 134 in the main body 122 and is movable between a retracted position, illustrated in FIG. 7, and an extended position, illustrated in FIG. 8. A piston 140 controls the actuation of the spool 136 and may be operated by any conventional means, such as hydraulically, pneumatically or the like.

Two inlet ports 152 and 154 in the main body 122 are fluidly connected to pressurized sources of polyol and isocyanate while a third port in the housing (not shown) is connected to a pressurized source of solvent. When the spool 136 is moved to its retracted position (FIG. 7), the

spool fluidly connects these ports 152 and 154 to the mixing chamber 124. Conversely, when the spool 136 is moved to its extended position, the spool fluidly connects the ports 152 and 154 to their respective recirculation ports 156 and 158.

Consequently, the second embodiment of the spray gun 120 is substantially identical to the first described embodiment of the spray gun 20 (FIGS. 1-6) except that the operation of the spool is reversed, i.e. the gun 120 dispenses the mixture when the spool 136 is retracted and recirculates the isocyanate, polyol and solvent when the spool 136 is extended. Therefore, a detailed description of the individual components of the spray gun is unnecessary since a full description of these components has already been set forth and is incorporated by reference.

10 Preferably the droplet size from the spray gun is less than 100 microns.

From the foregoing, it can be seen that the present invention provides a simple and yet highly effective spray gun for urethane. Having described our invention, however, many modifications thereto will become apparent to those skilled in the art to which it pertains without deviation from the spirit of the invention as defined by the scope of the appended claims.

15 We claim:

CLAIMS

1. A spray urethane gun assembly comprising:
- 2 a main body having a bore and a mixing chamber,
an elongated spool longitudinally slidably mounted in said main body bore and movable
- 4 between an extended position and a retracted position,
an actuator for moving said spool between said extended position and said retracted
- 6 position,
a first and second inlet ports formed in said main body,
- 8 a first and a second outlet ports formed in said main body,
a first axially extending fluid passageway formed in said spool, said first fluid
- 10 passageway fluidly connecting said first inlet port with said first outlet port when said spool is in
one of said retracted position or extended, and said first fluid passageway fluidly connecting said
- 12 first inlet port with said mixing chamber when said spool is in the other of said retracted or
extended position,
- 14 a second axially extending fluid passageway formed in said spool, said second fluid
passageway fluidly connecting said second inlet port with said second outlet port when said
- 16 spool is in said one of said retracted or extended position, and said second fluid passageway
fluidly connecting said second inlet port with said mixing chamber when said spool is in said
- 18 other of said retracted or extended position, and
a dispensing port formed in said main body and open to said mixing chamber.

2 2. The invention as defined in claim 1 and comprising a metering valve fluidly
2 connected between said first inlet port and said first fluid passageway.

2 3. The invention as defined in claim 1 and comprising a metering valve fluidly
2 connected between said second inlet port and said second fluid passageway.

2 4. The invention as defined in claim 1 wherein said actuator comprises a pneumatic
2 actuator.

2 5. The invention as defined in claim 4 and comprising a piston chamber formed in
2 said main body, a piston axially slidably mounted in said piston chamber, a first and second
pneumatic port formed in said main body, said first and second pneumatic ports being open to
4 said piston chamber on opposite ends of said piston, and said piston being mechanically
connected to said spool.

2 6. The invention as defined in claim 5 wherein said piston is attached to said spool
2 and moves in unison with said spool.

2 7. The invention as defined in claim 1 and comprises a dispensing wand having a
2 through passageway, one end of said wand through passageway being fluidly connected to said
dispensing port.

8. The invention as defined in claim 7 and comprising means for detachably
2 securing said wand to said main body.

9. The invention as defined in claim 8 wherein said securing means comprises a
2 threaded connection.

10. The invention as defined in claim 1 and comprising:
2 a third inlet ports formed in said main body,
a third outlet ports formed in said main body,
4 a third axially extending fluid passageway formed in said spool, said third fluid
passageway fluidly connecting said third inlet port with said third outlet port when said spool is
6 in said one of said retracted or extended position, and said third fluid passageway fluidly
connecting said third inlet port with said mixing chamber when said spool is in said other of said
8 retracted or extended position.

11. A spray urethane system comprising:
2 a spray gun assembly having a main body, said main body having a bore and a mixing
chamber,
4 an elongated spool longitudinally slidably mounted in said main body bore and movable
between an extended position and a retracted position,
6 an actuator for moving said spool between said extended position and said retracted
position,
8 a first and second inlet ports formed in said main body,

a first and a second outlet ports formed in said main body,

10 a first axially extending fluid passageway formed in said spool, said first fluid
passageway fluidly connecting said first inlet port with said first outlet port when said spool is in
12 one of said retracted or extended position, and said first fluid passageway fluidly connecting said
first inlet port with said mixing chamber when said spool is in the other of said retracted or
14 extended position,

a second axially extending fluid passageway formed in said spool, said second fluid
16 passageway fluidly connecting said second inlet port with said second outlet port when said
spool is in said one of said retracted or extended position, and said second fluid passageway
18 fluidly connecting said second inlet port with said mixing chamber when said spool is in said
other of said retracted or extended position,

20 a dispensing port formed in said main body and open to said mixing chamber,

a source of pressurized polyol fluidly connected to said first inlet port, said first outlet
22 port being fluidly connected to said source of polyol, and

a source of pressurized isocyanate fluidly connected to said second inlet port, said second
24 outlet port being fluidly connected to said source of isocyanate.

12. The invention as defined in claim 11 and comprising a metering valve fluidly
2 connected between said first inlet port and said first fluid passageway.

13. The invention as defined in claim 11 and comprising a metering valve fluidly
2 connected between said second inlet port and said second fluid passageway.

14. The invention as defined in claim 11 wherein said actuator comprises a pneumatic
2 actuator.

15. The invention as defined in claim 14 and comprising a piston chamber formed in
2 said main body, a piston axially slidably mounted in said piston chamber, a first and second
pneumatic port formed in said main body, said first and second pneumatic ports being open to
4 said piston chamber on opposite ends of said piston, and said piston being mechanically
connected to said spool.

16. The invention as defined in claim 15 wherein said piston is attached to said spool
2 and moves in unison with said spool.

17. The invention as defined in claim 11 and comprises a dispensing wand having a
2 through passageway, one end of said wand through passageway being fluidly connected to said
dispensing port.

18. The invention as defined in claim 17 and comprising means for detachably
2 securing said wand to said main body.

19. The invention as defined in claim 18 wherein said securing means comprises a
2 threaded connection.

20. The invention as defined in claim 11 and comprising:

2 a third inlet ports formed in said main body,
 a third outlet ports formed in said main body,
4 a third axially extending fluid passageway formed in said spool, said third fluid
 passageway fluidly connecting said third inlet port with said third outlet port when said spool is
6 in said one of said retracted or extended position, and said third fluid passageway fluidly
 connecting said third inlet port with said mixing chamber when said spool is in said other of said
8 retracted or extended position, and
 a source of pressurized colorant fluidly connected to said third inlet port, said third outlet
10 port being fluidly connected to said source of colorant.

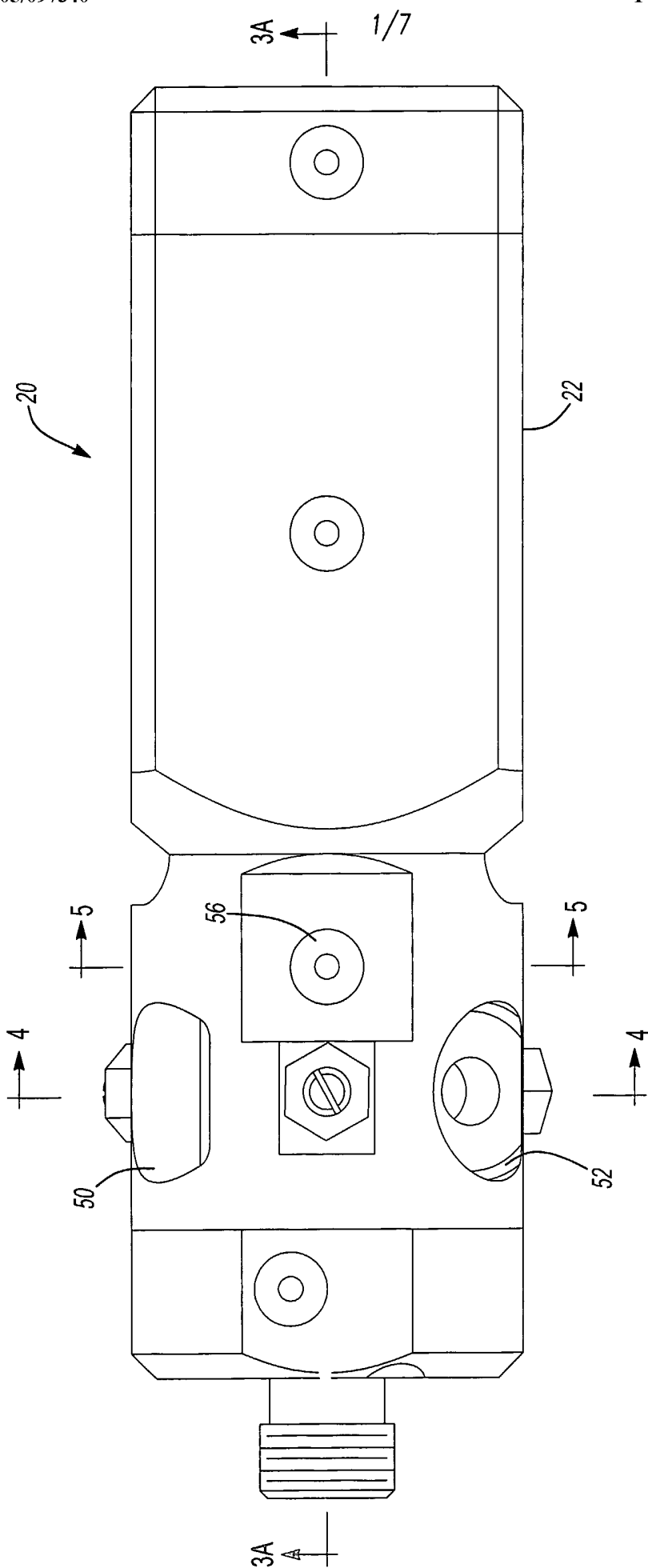

FIGURE - 1

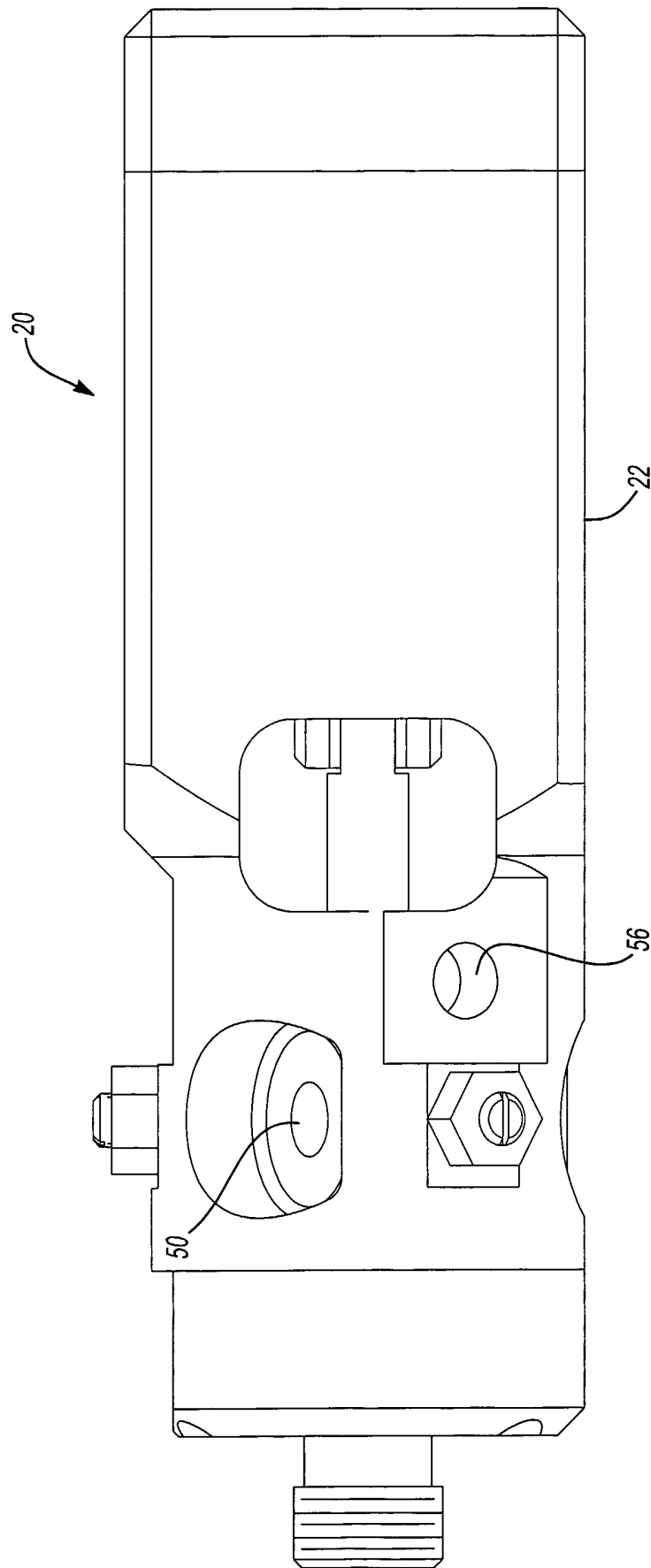
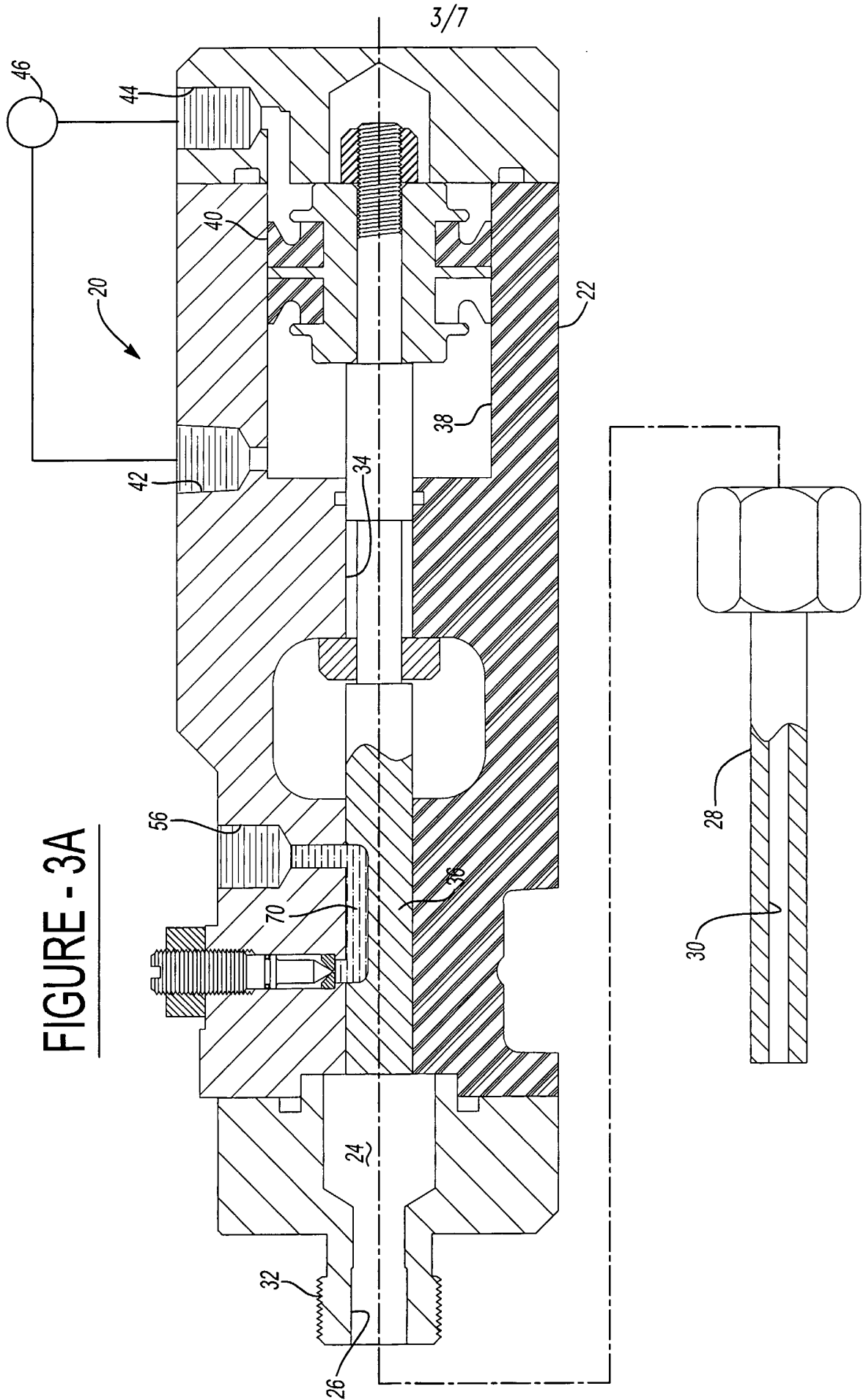

FIGURE - 2

FIGURE - 3A



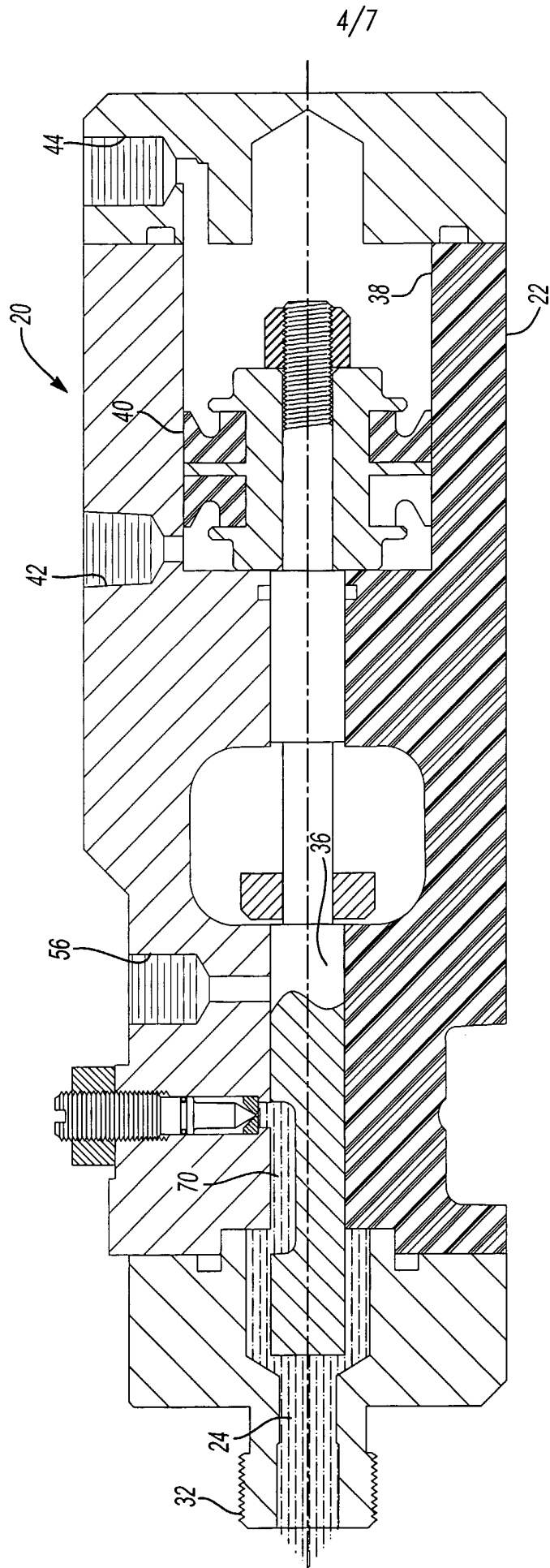

FIGURE - 3B

5/7

FIGURE - 4

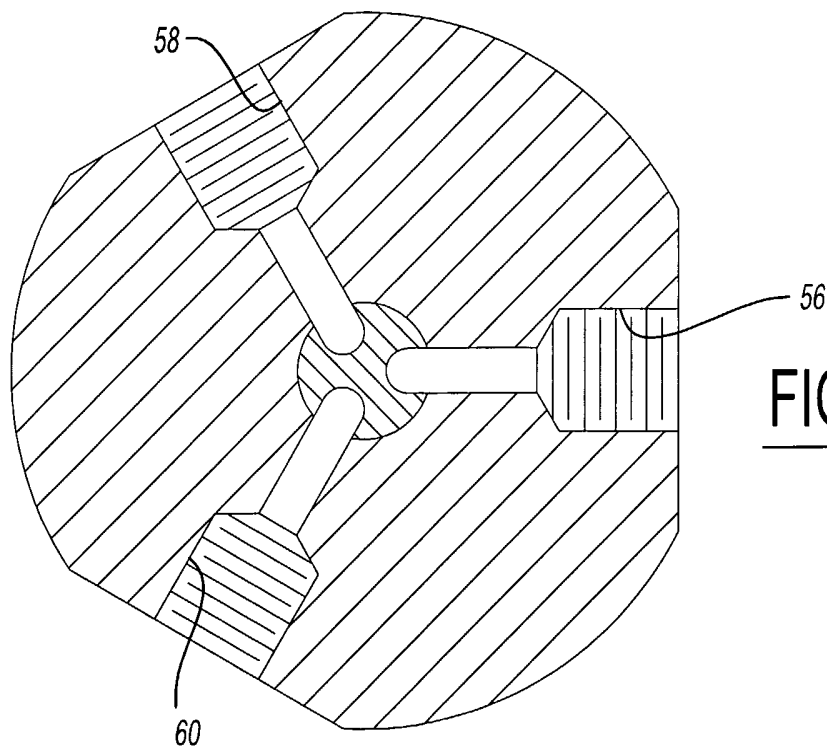
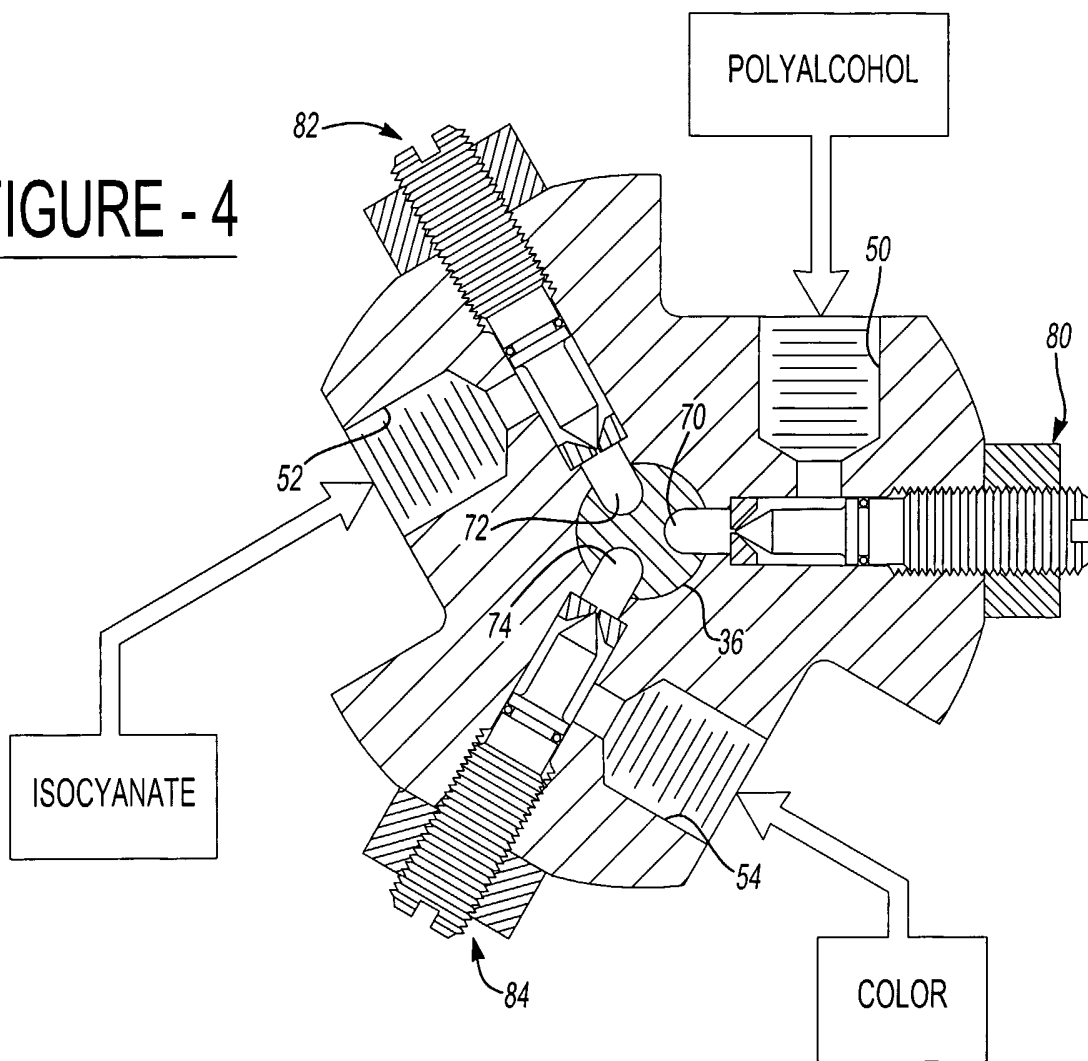

FIGURE - 5

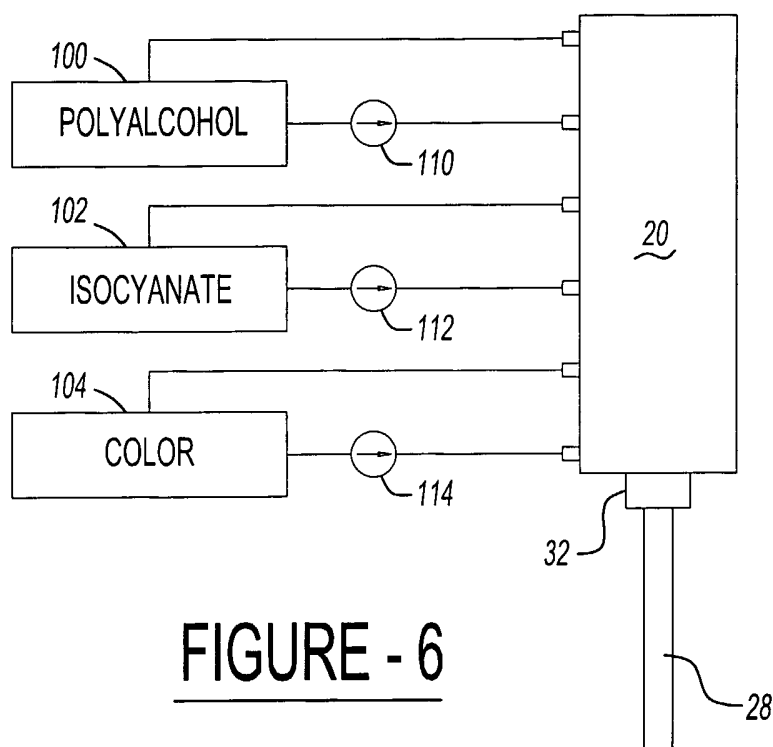

FIGURE - 6

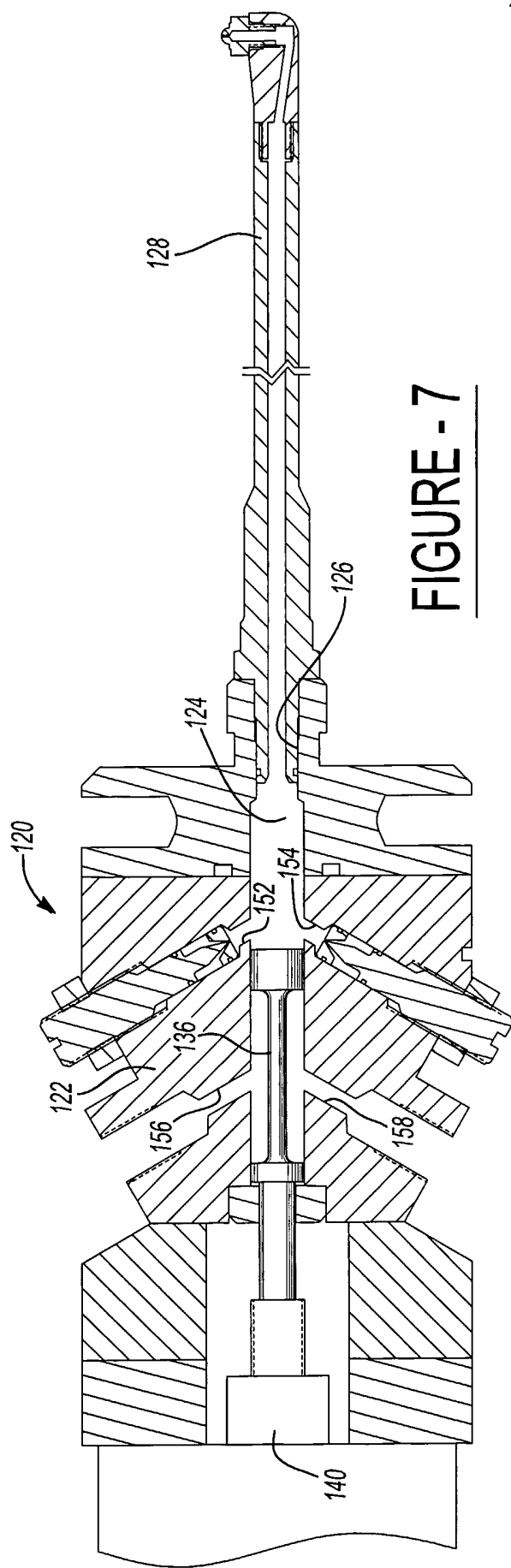

FIGURE - 7

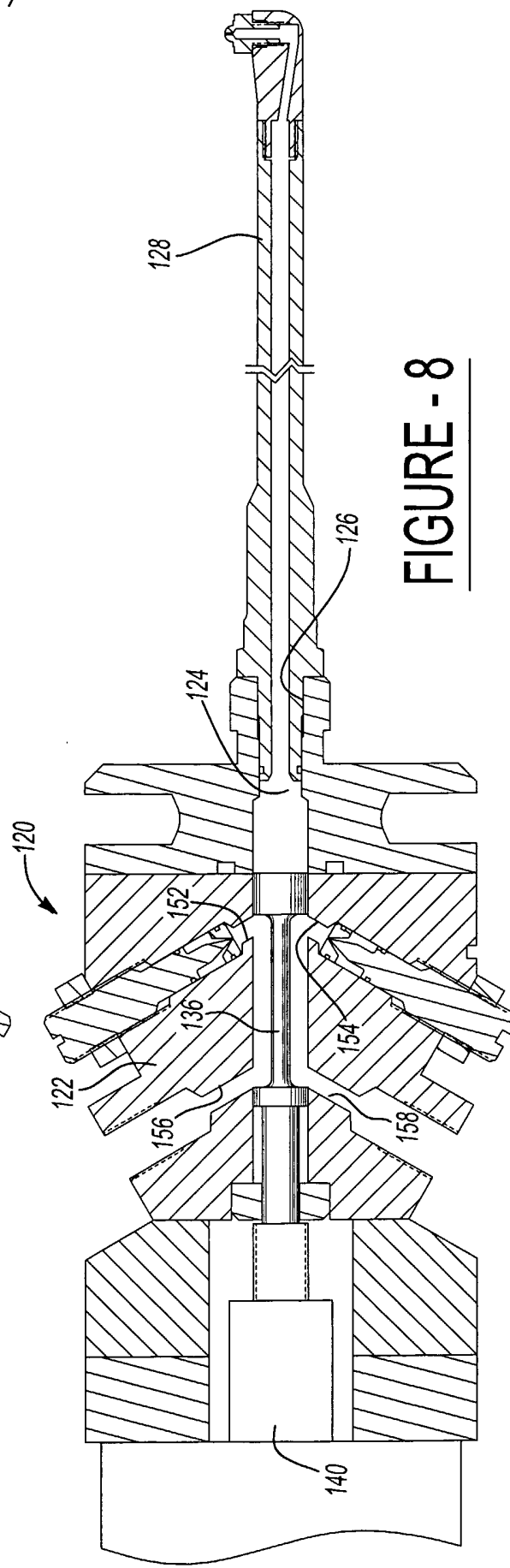

FIGURE - 8

INTERNATIONAL SEARCH REPORT

International application No.
PCT/IB2005/000903

A. CLASSIFICATION OF SUBJECT MATTER
IPC(7): B05B 7/04, B67D 5/16, B29C 44/34

According to International Patent Classification (IPC) or to both national classification and IPC

B. FIELDS SEARCHED

Minimum documentation searched (classification system followed by classification symbols)
IPC7 B05B*, B67D*, B29C*

Documentation searched other than minimum documentation to the extent that such documents are included in the fields searched

Electronic database(s) consulted during the international search (name of database(s) and, where practicable, search terms used)
Delphion, CPD, USPTO, espacenet, Qpat, internet

C. DOCUMENTS CONSIDERED TO BE RELEVANT

Category*	Citation of document, with indication, where appropriate, of the relevant passages	Relevant to claim No.
X	CA 1,303,567 (Insta-Foam Products, Inc.) June 16, 1992 -- see the whole document	1 to 20
X	CA 2,428,087 (Flexible Products Company) September 26, 2002 -- see the whole document	1 to 20
Y	CA 1,246,503 (Gusmer Corporation) December 13, 1988 -- see the whole document	1 to 20

Further documents are listed in the continuation of Box C.

See patent family annex.

<p>* Special categories of cited documents :</p> <p>"A" document defining the general state of the art which is not considered to be of particular relevance</p> <p>"E" earlier application or patent but published on or after the international filing date</p> <p>"L" document which may throw doubts on priority claim(s) or which is cited to establish the publication date of another citation or other special reason (as specified)</p> <p>"O" document referring to an oral disclosure, use, exhibition or other means</p> <p>"P" document published prior to the international filing date but later than the priority date claimed</p>	<p>"T" later document published after the international filing date or priority date and not in conflict with the application but cited to understand the principle or theory underlying the invention</p> <p>"X" document of particular relevance; the claimed invention cannot be considered novel or cannot be considered to involve an inventive step when the document is taken alone</p> <p>"Y" document of particular relevance; the claimed invention cannot be considered to involve an inventive step when the document is combined with one or more other such documents, such combination being obvious to a person skilled in the art</p> <p>"&" document member of the same patent family</p>
----------------------------------------------------------------------------------------------------------------------------------------------------------------------------------------------------------------------------------------------------------------------------------------------------------------------------------------------------------------------------------------------------------------------------------------------------------------------------------------------------------------------------------------------------------------------------------------------------------------------------------------------------	-----------------------------------------------------------------------------------------------------------------------------------------------------------------------------------------------------------------------------------------------------------------------------------------------------------------------------------------------------------------------------------------------------------------------------------------------------------------------------------------------------------------------------------------------------------------------------------------------------------------------------------------------------------------------------------------------------------------

Date of the actual completion of the international search

11 August 2005 (11-08-2005)

Date of mailing of the international search report

17 August 2005 (17-08-2005)

Name and mailing address of the ISA/CA
Canadian Intellectual Property Office
Place du Portage I, C114 - 1st Floor, Box PCT
50 Victoria Street
Gatineau, Quebec K1A 0C9
Facsimile No.: 001(819)953-2476

Authorized officer

Steven M. Tupper (819) 997-2786

INTERNATIONAL SEARCH REPORT

International application No.
PCT/IB2005/000903

Patent Document	Publication Date	Family Members	Publication Date
CA 1,303,567	June 16, 1992	AU 593265 B2 AU 614887 B2 AU 4540589 A AU 6009586 A BE 905099 A1 DE 3624040 A1 DE 3624040 C2 FR 2584951 A1 FR 2584951 B1 GB 2177942 A GB 2177942 B GB 8617102D D0 JP 6098285B B JP 62038228 A LU 86512 A1 NL 194199B B NL 194199C C NL 8601863 A US 4676437 A US 4925107 A ZA 8506119 A	February 8, 1990 September 12, 1991 March 29, 1990 January 22, 1987 November 3, 1986 February 5, 1987 March 18, 1999 January 23, 1987 May 12, 1989 February 4, 1987 August 2, 1989 August 20, 1986 December 7, 1994 February 19, 1987 December 2, 1986 May 1, 2001 September 4, 2001 February 16, 1987 June 30, 1987 May 15, 1990 April 29, 1987
CA 2,428,087	September 26, 2002	EP 1334308 A1 EP 1334308 A4 JP2004538126T T US2003116647 A1 WO 0275210 A1	August 13, 2003 March 10, 2004 December 24, 2004 June 26, 2003 September 26, 2002
CA 1,246,503	December 13, 1988	AU 4097185 A EP 0164840 A1 JP 60248324 A US 4523696 A	October 17, 1985 December 18, 1985 December 9, 1985 June 18, 1985