



- (51) International Patent Classification:
G06F 17/50 (2006.01)
- (21) International Application Number:
PCT/US2012/051204
- (22) International Filing Date:
16 August 2012 (16.08.2012)
- (25) Filing Language: English
- (26) Publication Language: English
- (30) Priority Data:
13/212,061 17 August 2011 (17.08.2011) US
- (71) Applicant (for all designated States except US): **SYN-OPSYS, INC.** [US/US]; 700 E. Middlefield Rd., Mountain View, CA 94043 (US).
- (72) Inventor; and
- (75) Inventor/Applicant (for US only): **ARUNACHALAM, Anand** [US/US]; 1470 Hollenbeck Avenue, Sunnyvale, CA 94087 (US).

AO, AT, AU, AZ, BA, BB, BG, BH, BN, BR, BW, BY, BZ, CA, CH, CL, CN, CO, CR, CU, CZ, DE, DK, DM, DO, DZ, EC, EE, EG, ES, FI, GB, GD, GE, GH, GM, GT, HN, HR, HU, ID, IL, IN, IS, JP, KE, KG, KM, KN, KP, KR, KZ, LA, LC, LK, LR, LS, LT, LU, LY, MA, MD, ME, MG, MK, MN, MW, MX, MY, MZ, NA, NG, NI, NO, NZ, OM, PE, PG, PH, PL, PT, QA, RO, RS, RU, RW, SC, SD, SE, SG, SK, SL, SM, ST, SV, SY, TH, TJ, TM, TN, TR, TT, TZ, UA, UG, US, UZ, VC, VN, ZA, ZM, ZW.

- (84) Designated States (unless otherwise indicated, for every kind of regional protection available): ARIPO (BW, GH, GM, KE, LR, LS, MW, MZ, NA, RW, SD, SL, SZ, TZ, UG, ZM, ZW), Eurasian (AM, AZ, BY, KG, KZ, RU, TJ, TM), European (AL, AT, BE, BG, CH, CY, CZ, DE, DK, EE, ES, FI, FR, GB, GR, HR, HU, IE, IS, IT, LT, LU, LV, MC, MK, MT, NL, NO, PL, PT, RO, RS, SE, SI, SK, SM, TR), OAPI (BF, BJ, CF, CG, CI, CM, GA, GN, GQ, GW, ML, MR, NE, SN, TD, TG).

Declarations under Rule 4.17:

- as to applicant's entitlement to apply for and be granted a patent (Rule 4.17(ii))

Published:

- with international search report (Art. 21(3))

[Continued on next page]

- (54) Title: METHOD AND APPARATUS FOR AUTOMATIC RELATIVE PLACEMENT GENERATION FOR CLOCK TREES

(57) Abstract: Methods and apparatuses are disclosed for automatic relative placement of part of a clock tree in the course of generating a placed, routed, and optimized circuit design.

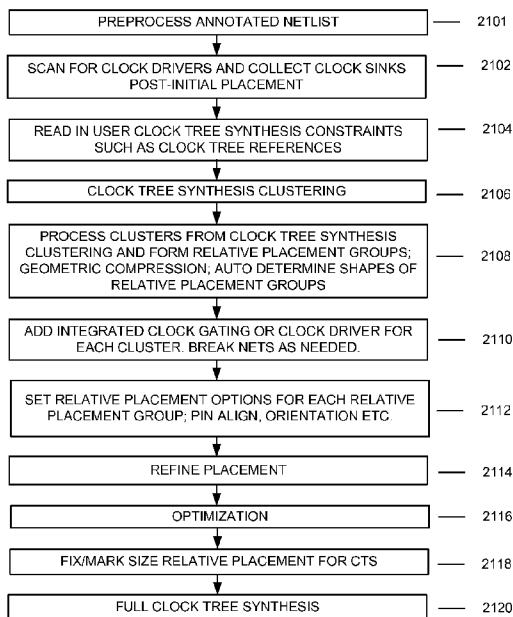

Fig. 21



- *before the expiration of the time limit for amending the claims and to be republished in the event of receipt of amendments (Rule 48.2(h))*

**METHOD AND APPARATUS FOR AUTOMATIC RELATIVE PLACEMENT
GENERATION FOR CLOCK TREES**

Inventors: Anand Arunachalam

BACKGROUND

Field of the Invention

[0001] The technology relates to integrated circuit fabrication, and more particularly to placement, routing, and optimization of an integrated circuit design that obeys rules that specify the relative placement of circuit elements.

Description of Related Art

[0002] An integrated circuit design flow typically proceeds through the following stages: product idea, EDA software, tapeout, fabrication equipment, packing/assembly, and chips. The EDA software stage includes the steps shown in the following table:

EDA step	What Happens
System Design	- Describe the functionality to implement - What-if planning - Hardware/software architecture partitioning
Logic Design and Functional Verification	- Write VHDL/ Verilog for modules in system - Check design for functional accuracy, does the design produce correct outputs?
Synthesis and Design for Test	- Translate VHDL/Verilog to netlist - Optimize netlist for target technology - Design and implement tests to permit checking of the finished chip
Design Planning	- Construct overall floor plan for the chip - Analyze same, timing checks for top-level routing
Netlist Verification	- Check netlist for compliance with timing constraints and the VHDL/Verilog
Physical Implement.	- Placement (positioning circuit elements) and routing (connecting circuit elements)
Analysis and Extraction	- Verify circuit function at transistor level, allows for what-if refinement
Physical Verification (DRC, LRC, LVS)	- Various checking functions: manufact., electrical, lithographic, circuit correctness
Resolution Enhanc. (OPC, PSM, Assists)	- Geometric manipulations to improve manufacturability
Mask Data Preparation	- "Tape-out" of data for production of masks for lithographic use produce finished chips

[0003] With regard to physical implementation technology, methodologies for structured placement offer circuit designers superior power, yield, and/or area for a given logic function. With the advent of manual placement of transistors, designers created arrayed layouts where logic gates were manually placed in a regularized fashion. This methodology has evolved to the point that automation has been applied to the problem. However, regularized placement still suffers from a great deal of manual effort, such as in cell drive strength selection.

[0004] Capturing a priori designer knowledge of structured placement requirements in HDL is a nontrivial problem. Even if captured, structured placement requirements are lost during standard cell random placement. Standard cell placers tend to take more localized views during optimization. This results in not just loss of regularity, but also extra buffering, routing, vias, and cell oversizing, compared to a solution which might be obtained following structured placement.

[0005] One approach to this problem is to perform cell sizing and optimization of a structured placement manually through homegrown tools. This approach is quite expensive in terms of engineering effort. This approach is also hard to integrate with the rest of the design. Such integration requires multiple iterations, because standard cell placement and optimization changes the placement, sizing, etc. of the surrounding, non-structured logic. Unfortunately, this triggers another iteration, with further manual sizing and optimization efforts through the homegrown tools for the block with structured placement.

[0006] Other approaches to this problem are to generate structured placement through synthesis or through a specific tool, and then pass on the result to a placer through a set of special constraints, or as a macro/IP block. The initial structure generated through synthesis or through the special tool is problematic. Because the initial structure is generated prior to placement, the initial structure is formed lacking complete placement knowledge, and thus the initial structure fails to lead to optimal placement as generation. Also if it is passed as a macro/IP block, then place and route tools cannot resize or otherwise optimize the blocks.

[0007] Relative placement rules as applied to clock trees are problematic. Several of the disadvantages follow. Relative placement rules specified in a scripting language such TCL can require updates as the relative placement language changes. The design can be over-constrained and more clock gates inserted than needed, and clock gate incorrectly sized. A manual iterative process of figuring the maximum distance of the flip-flops to cluster is labor intensive. There can be inability to cluster and create smaller relative placement groups when a clock gate drives more than the maximum fanout limit of a clock gate. It is labor intensive to manually create relative placement rules and manually modify the netlist (connect/disconnect gates/flops) and

insert clock buffers and create relative placement structures. Non-convergence can be caused by using ad-hoc/distance based techniques up front in placement/optimization versus a native clock tree clustering algorithm used in clock tree synthesis, as they are not the same processes.

[0008] Therefore, it would be desirable to efficiently implement structured placement with circuit design.

SUMMARY

[0009] One aspect of the technology is a method of circuit design with a computer system. The method includes generating with the computer system a placed, routed, and optimized circuit design. Generating the circuit design includes guiding coarse placement of the circuit design according to rules created specifically and automatically for a set of circuit elements in a netlist of the circuit design including clock network flip-flops. The rules specify positioning of each circuit element of the set of circuit elements in the circuit design relative to other circuit elements of the set of circuit elements in the circuit design. Generating the circuit design also includes completing placement, routing, and optimization of the netlist of the circuit design according to the rules.

[0010] Various embodiments can include one or more of the following features.

[0011] The method further includes, after the coarse placement and before clock tree synthesis of the circuit design, automatically creating the clock network flip-flops in the netlist of the circuit design.

[0012] The method further includes, after the coarse placement and before clock tree synthesis of the circuit design, automatically creating the clock network flip-flops in the netlist of the circuit design based on clock sinks in the netlist.

[0013] The method further includes, after the coarse placement and before clock tree synthesis of the circuit design, automatically grouping the clock network flip-flops into a plurality of flip-flop groups.

[0014] The method further includes, after the coarse placement and before clock tree synthesis of the circuit design, automatically grouping the clock network flip-flops into a plurality of flip-flop groups. The rules automatically created for the clock network flip-flops are based on the plurality of flip-flop groups.

[0015] The method further includes, after the coarse placement and before clock tree synthesis of the circuit design, performing clock tree clustering that automatically groups the clock network flip-flops into a plurality of flip-flop groups.

[0016] The method further includes, after the coarse placement and before clock tree synthesis of the circuit design, performing clock tree clustering that automatically groups the clock network flip-flops into a plurality of flip-flop groups, without creating clock network buffer circuitry.

[0017] The method further includes, after the coarse placement and before clock tree synthesis of the circuit design, performing clock tree clustering that automatically groups the clock network flip-flops into a plurality of flip-flop groups. The rules automatically created for the clock network flip-flops are based on the plurality of flip-flop groups from the clock tree clustering.

[0018] The method further includes, after the coarse placement and before clock tree synthesis of the circuit design, performing clock tree clustering that automatically groups the clock network flip-flops into a plurality of flip-flop groups. The method further includes, during placement of the circuit design, automatically creating clock network buffer circuitry for the plurality of flip-flop groups.

[0019] In the method, the clock network flip-flops are leaf nodes of a clock tree of the circuit design.

[0020] The method further includes, during placement of the circuit design, automatically adding clock network buffer circuitry matched to the grouped clock network flip-flops in the circuit design.

[0021] In the method, the rules obey clock tree constraints specified for the circuit design.

[0022] Other aspects of the technology can be embodied in a corresponding system, apparatus, and computer readable medium.

[0023] The data processing system is adapted to process a computer implemented representation of a circuit design. The system has a data processor and memory coupled to the data processor. The memory stores instructions executable by the data processor. The instructions perform a process as described herein.

[0024] The apparatus can be a circuit. The circuit follows a placed, routed, and optimized circuit design. The placed, routed, and optimized circuit design is created by a process as described herein.

[0025] The computer readable medium has computer readable instructions executable by a computer system. The instructions perform a process as described herein.

[0026] Other embodiments include a computer readable medium with computer readable instructions for circuit design, with computer instructions that perform the technology described

herein; a circuit design generated with the technology described herein; and an electrical circuit with circuitry designed by the technology described herein.

BRIEF DESCRIPTION OF THE DRAWINGS

- [0027] Figure 1 is a flow diagram illustrating an exemplary process for using relative placement in circuit design.
- [0028] Figure 2 is a flow diagram illustrating an exemplary process of the placement, routing, and optimization tool.
- [0029] Figure 3 shows the placement, as a single unit, of a group of circuit elements following relative placement rules.
- [0030] Figure 4 shows circuit elements organized by relative placement rules into columns and rows.
- [0031] Figure 5 shows the creation of a hierarchy of circuit elements organized by relative placement rules.
- [0032] Figure 6 shows the creation of a multiple instances of circuit elements hierarchically organized by relative placement rules.
- [0033] Figure 7 shows an ungrouped version of the circuit design of Figure 6.
- [0034] Figure 8 shows a circuit design with keepouts defined by the relative placement rules.
- [0035] Figure 9 shows cells that straddle multiple columns and multiple rows as defined by the relative placement rules.
- [0036] Figure 10 shows the creation of a hierarchy of circuit elements organized by relative placement rules that permit straddling of multiple rows and multiple columns.
- [0037] Figure 11 shows a circuit design organized by relative placement rules with orientation optimization and pin alignment.
- [0038] Figure 12 shows a relative placement group of a circuit design aligned by pins.
- [0039] Figure 13 shows a relative placement group of a circuit design aligned by multiple pins.
- [0040] Figure 14 shows a relative placement block of a circuit design that contains a group aligned by pins.
- [0041] Figure 15 shows a relative placement block of a circuit design anchored at the x-coordinate and the y-coordinate.
- [0042] Figure 16 shows multiple relative placement blocks of a circuit design aligned and anchored vertically at four coordinates.

[0043] Figure 17 shows circuit elements with and without compression specified by relative placement rules.

[0044] Figure 18 shows the placement of relative placement cells in a circuit design containing keepouts.

[0045] Figure 19 is a simplified block diagram of a computer system suitable for use with embodiments of the technology, as well as a circuit design and circuit embodiments of the technology.

[0046] Figure 20 is a flow diagram illustrating an exemplary process of the placement, routing, and optimization tool with clock tree synthesis clustering being performed during placement.

[0047] Figure 21 is a flow diagram illustrating another exemplary process of the placement, routing, and optimization tool with clock tree synthesis clustering being performed during placement.

DETAILED DESCRIPTION

[0048] Relative placement information generates a structure of the instances and controls the placement of the instances. The resulting annotated netlist is used for physical optimization, during which the placement, routing, and optimization tool preserves the structure.

[0049] Figure 1 shows the overall flow for using relative placement. Relative placement usually is applied to datapaths and registers, but relative placement can be applied to any cells in a circuit design, controlling the exact relative placement topology of gate-level logic groups and defining the circuit layout.

[0050] At 110, a mapped netlist (a structural interconnection of library cells) is read. At 140, a netlist annotator adds annotations of the relative placement constraints to the mapped netlist. The relative placement constraints may have come from an automatic rule creator 120, which generates automatically created relative placement rules 125. Also, the relative placement constraints may have come from the circuit designer/custom tool 130, which generates relative placement rules created by the circuit designer 135. Based on the mapped netlist 110 and the relative placement rules, the netlist annotator 140 generates a netlist annotated with relative placement rules 145.

[0051] The netlist annotator 140, which may be GUI-based or text-based provides a way create relative placement structures for the placement, routing, and optimization tool 150. In a GUI-based annotator, the relative placement can be specified by drag-and-drop of circuit elements into positions relative to other circuit elements. Clicking multiple circuit elements and

assigning an identifier such as a color, a pattern, or a name can define multiple groups with respective relative placement rules. With a text-based annotator, relative column and row positions can be specified of instances with respect to each other. These placement constraints create relative placement structures that are preserved during placement and legalization.

Whether GUI-based or text-based, the cells in each structure group are placed as a single entity.

[0052] The placement, routing, and optimization tool 150 receives the netlist annotated with relative placement rules 145 and generates the placed, routed, and optimized netlist obeying relative placement rules 155. The optimization includes, for example, orientation optimization.

[0053] Figure 2 shows an exemplary process flow of a placement, routing, and optimization tool. At 201, an annotated netlist is preprocessed for the relative placement annotation. Data structures are created to carry relative placement information. At 202, the sizes of relative placement blocks and aspect ratios are estimated by applying relative placement rules for each relative placement block. Any hierarchical relative placement blocks are estimated also. At 204, each of the estimated relative placement blocks is modeled for coarse placement purposes, for example as a macro with pin locations visible but the internal cells hidden from the coarse placer. At 206, the relative placement blocks are placed within the context of entire design, including the cells which have the relative placement rules simultaneously along with the cells which do not have relative placement rules. Among the relative placement blocks of cells, the blocks are placed one at a time. At 208, if needed another incremental placement is done for area recovery of sparse relative placement blocks. One block at a time is fixed based on the locations returned by the coarse placer. Individual relative placement instances are fixed before such area recovery. At 210, individual instances of cells are readjusted within each relative placement block, based on new locations determined by the placer according to the optimization constraints. User constraints are respected for each relative placement block. At 212, the nearest legal locations for all the relative placement cells are found, and the relative placement cells fixed there. Any overlaps of relative placement blocks are resolved by checking each of the already fixed blocks and making sure that the moved blocks do not overlap with them. If overlaps occurs, the moved blocks are moved with minimal movement as the cost. At 214, detailed placement is done for the non-relative placement cells, considering the fact that cells with relative placement are already fixed. At 216, all relative placement cells are unfixed. If optimization and relative placement constraints are met, then the tool can stop, finish writing out the placed and routed netlist, and exit the placement and optimization process. At 218, physical optimization is done for all the instances, including relative placement instances, to meet timing or any other user specified goals. This could focus on the most critical objectives such as timing,

respecting design rules, congestion, wire length etc. The optimization includes, for example, orientation optimization. At 220, relative placement constraints are reapplied, and locations readjusted based on optimization results. Thus, the relative placement constraints specified in the annotated netlist are preserved. The process then loops back to 212.

[0054] The above process can be rearranged, for example by combining, adding, removing, or modifying steps. For example, 212-216 can be rearranged, depending on the design, and 208 and 210 can be combined into one step.

[0055] Benefits of Relative Placement

[0056] Various embodiments that implement relative placement provide one or more of the following benefits:

[0057] 1) Provides a method to maintain structured placement for legacy or intellectual property (IP) designs using a placement, routing, and optimization tool.

[0058] 2) Handles flat and hierarchical designs.

[0059] 3) For complex designs, a typical design can have many engineers working on it and many blocks. Hierarchical relative placement enables placing those blocks together relative to each other more easily. Any number of levels of hierarchies are allowed.

[0060] 4) Reduces the placement search space in critical areas of the design resulting in greater predictability of QoR (wire length, timing, power) and congestion.

[0061] 5) Is technology independent.

[0062] 6) Improves routability.

[0063] Relative Placement Considerations

[0064] Various embodiments that implement relative placement require one or more of the following considerations:

[0065] 1) When the placement, routing, and optimization tool estimates that the size of a relative placement block is not suitable to the given floorplan, the placement, routing, and optimization tool can fail in placement. To maintain relative placement information precisely, there should be enough space for relative placement blocks without overlapping placement obstructions in the design floorplan.

[0066] 2) If the design contains multiheight cells and exact relative placement (perfect alignment of the cells on one or more sides of the row or column) is used, the current relative placement implementation might not get perfect alignment in every case.

[0067] 3) There is no limit on the number of cells in a relative placement group. However, if the design has many relative placement groups, at times coarse placement returns overlapping group locations, resulting in misalignment. In these cases, a warning

appears after coarse placement.

[0068] The following is a specific exemplary implementation of the discussed process flow. Many of the examples which follow are implemented with a text-based shell. The text-based examples are provided for in an exemplary Synopsys™ design environment for the purposes of illustration. The examples are also applicable to a GUI-based environment, in which the text-based commands are replaced or complemented with a mouse-driven interface.

[0069] **Exemplary Relative Placement Flow**

[0070] Implementing the methodology for the relative placement flow follows several steps.

[0071] 1. In a design environment that permits a user to decide whether or not to use relative placement, relative placement is enabled. Relative placement is enabled by entering “XG mode”, performed by entering the shell command: `psyn_shell-xg-t> set physopt_enable_rp_in_xg_mode "true"`

[0072] 2. The gate-level netlist is prepared and read it in to the placement, routing, and optimization tool, using the `read_milkyway` or `read_db` command.

[0073] 3. The relative placement data are prepared.

[0074] Create the relative placement groups. Use the `create_rp_group` command.

[0075] Add relative placement items to the groups. Use the `add_to_rp_group` command.

[0076] The netlist annotator annotates the netlist with the relative placement information, and generates a placed netlist containing the data.

[0077] 4. Preserve the relative placement information in the annotated netlist. Use `set_size_only` to preserve relative placement information for cells that contain it. For example, enter

```
psyn_shell-xg-t> set_size_only {RP_cells} true
```

[0078] 5. Set the block utilization of the relative placement block. The block utilization is how densely a block is packed. A value of 1 indicates no gap between columns. It could vary between 0 and less than or equal to 1. Enter

```
psyn_shell-xg-t> set physopt_use_block_utilization true
```

[0079] The default value is 1.0.

[0080] 6. Read floorplan information. For example, enter

```
psyn_shell-xg-t> read_pdef top.pdef
```

[0081] 7. Perform coarse placement for the design. Use the `create_placement` command.

[0082] 8. Analyze the design using the placement, routing, and optimization tool GUI.

[0083] 9. If the relative placement result is not acceptable, modify the relative placement file and run this procedure again.

[0084] If the relative placement is acceptable, then perform optimization, by running physopt.

[0085] Sample Script for a Relative Placement Flow

[0086] The following is a sample script for running a relative placement flow.

```
# Set library and design paths #
source setup.tcl
set physopt_enable_rp_in_xg_mode "true"
# Read db file generated from rp_reader #
read_db block_rp.db
read_db block2_rp.db
read_db other_blocks.db
read_db top.db
current_design top
link
link_physical_library
# Create relative placement #
create_rp_group
...
add_to_rp_group
...
# Apply constraints #
source constraints.tcl
# Apply set_size_only on relative placement cells to preserve relative placement
information #
set_size_only {RP_cells} true
# Read floorplan information #
read_pdef top.pdef
# Perform coarse placement on the design #
create_placement
# Perform analysis. If okay, do physical synthesis or #
# incremental physical synthesis #
physopt or physopt -incremental
```

[0087] Considerations for Using Relative Placement

[0088] A design can contain both structured and unstructured items (leaf cells, keepouts, hierarchical groups). Control of which cells are to be structured is accomplished by including the cells to be structured in a relative placement group.

[0089] Determining which portions of the module need to be structured is beneficial. Providing relative placement information for cells that would have been placed better by allowing the placement, routing, and optimization tool to place the cells can produce poor results.

[0090] Some designs are appropriate for structured placement (for example, datapaths), whereas others are more appropriate for usual placement by the placement, routing, and optimization tool.

[0091] Data Required for Relative Placement

[0092] Relative placement requires a gate-level netlist. The format can be any format read by the placement, routing, and optimization tool.

[0093] Commands for Relative Placement

[0094] The basic functionality for relative placement is carried out by way of dedicated Tcl commands used within the placement, routing, and optimization tool. The commands create groups and add leaf cells, hierarchy, and keepouts to the groups. In addition, a script of annotated information can be generated, edited, and reapplied to the design, and relative placement groups can be removed.

[0095] In addition to these dedicated commands, physical synthesis commands are available.

[0096] Commands Specific to Relative Placement

[0097] Relative placement uses the dedicated commands listed in Table 1.

[0098] Table 1 Dedicated Commands for Relative Placement

Command	Described in section
create_rp_group	See “Creating Relative Placement Groups”.
add_to_rp_group	See “Adding Items to a Group”.
write_rp_group	See “Writing Relative Placement Information to a Script File”.
remove_rp_group	See “Removing Relative Placement Information”.

[0099] Other Commands Often Used for Relative Placement

[00100] The commands listed in Table 2 are often used for relative placement.

[00101] Table 2 Other Commands Often Used for Relative Placement

Command	Described in section
set_size_only	See “Preserving Relative Placement Information During Optimization”.
create_bounds	See “Constraining Relative Placement Cell Placement Using Placement Bounds”.
find	Locates and returns a collection of relative placement groups that match listed names. The man page has information.
source	Loads and runs a script file. The man page has information.

[00102] Preserving Relative Placement Information During Optimization

[00103] The relative placement information for an instance is attached to the instance. During optimization, relative placement cells can be optimized or removed. When an instance with relative placement information is removed during optimization, relative placement information attached to the instance is also removed.

[00104] To prevent relative placement cells from being removed during optimization, apply set_size_only to true on leaf cells to preserve relative placement information for cells that contain it. If relative placement cells are upsized or downsized, the relative placement cell alignment is maintained for placement.

[00105] Constraining Relative Placement Cell Placement Using Placement Bounds

[00106] The placement of relative placement cells is constrained by defining placement bounds. To do this, use the create_bounds command. Both soft bounds and hard bounds are supported for relative placement cells and both rectangular bounds and rectilinear bounds are supported.

[00107] Note: In relative placement, only move bounds (with fixed coordinates) are supported for relative placement cells. Group bounds are not supported. In other embodiments, group bounds are supported in relative placement.

[00108] Specify individual cell names as provided in an add_to_rp_group command with the create_bounds command. For example, enter

```
psyn_shell-xg-t> create_bounds -coordinates {100 100 200 200} U1 U2 U3 U4
```

[00109] In other embodiments, a relative placement group is specified.

[00110] If some cells of a relative placement group are specified to be inside a bound and some cells are not specified to be inside the bound, cells that are not constrained by the bound are placed as loose cells. This can lead to legally correct but possibly poor placement QoR.

[00111] Ignoring Relative Placement Information

[00112] The tool can be directed to ignore relative placement information annotated to the design, for example, when to confirm that relative placement is helpful to QoR. To do this, set the variable `physopt_ignore_structure` to true (default is false).

[00113] Setting this variable to true causes the placement, routing, and optimization tool not to do structured placement for any relative placement groups in the design.

[00114] When the tool is directed to ignore relative placement information, the parts of the relative placement groups are placed as if the group has no relative placement information.

[00115] Removing Relative Placement Information

[00116] Relative placement annotation can be removed from an annotated database for one or more relative placement groups. To do this, use the `remove_rp_group` command.

[00117] Note: When a relative placement group is removed, the memory it occupies is freed to be reused by this same process. However, memory is not returned to the operating system until exit from `psyn_shell`.

[00118] To remove relative placement groups, enter
`psyn_shell-xg-t> remove_rp_group [options]`

To do this	Use this
List the relative placement groups to remove. (vs. using <code>-all</code>).	<code>group_list</code>
Remove all relative placement groups. (vs. using <code>-all</code>).	<code>-all</code>
Remove all the designs within the hierarchies of the groups listed in the group list. By omitting this option, subgroups are not removed. (vs. using <code>-all</code>).	<code>-hierarchy</code>
During removal, disable printing the groups being removed.	<code>-quiet</code>

[00119] Example

[00120] To remove the relative placement group named `grp_ripple` and confirm its removal, enter

```

psyn_shell-xg-t> find rp_group
{mul::grp_mul ripple::grp_ripple xample3::top_group}
psyn_shell-xg-t> remove_rp_group grp_ripple
Removing rp group 'ripple::grp_ripple'
1
psyn_shell-xg-t> find rp_group grp_ripple
Error: Can't find object 'grp_ripple'. (UID-109)
psyn_shell-xg-t> remove_rp_group -all
Removing rp group 'mul::grp_mul'
Removing rp group 'example3::top_group'
1

```

[00121] **Modifying Relative Placement Information**

[00122] A relative placement group can be modified. For example:

[00123] • Remove items from a group

[00124] • Rename a group

[00125] • Move an item from one position to another

[00126] • Realign or reorient items

[00127] A group can be modified in the following ways:

[00128] • Remove the group to be changed, then create a new group that incorporates the changes.

[00129] • Generate a script (using write_rp_group) and edit the information in the generated script.

[00130] **Creating Relative Placement Groups**

[00131] A relative placement group is an association of cells, other groups, and keepouts. During placement and legalization, the group structure is preserved and the cells in the group are placed as a single entity. To create a group, use the create_rp_group command. The group is placed as a single entity, as shown in Figure 3. In Figure 3, floorplan 302 is shown. The group 306 includes cells 310 and obstructions 312. The group can be moved 308 as a single unit. The floorplan 302 also has RAM 304 which is fixed in place.

[00132] **Positions for Columns and Rows in Relative Placement Data**

[00133] Figure 4 shows the positions for columns and rows in relative placement data 400. Columns count from column 0 (the leftmost column). Rows count from row 0 (the bottom row).

The width of a column is the width of the widest cell in that column. The height of a row is determined by the height of the tallest cell in that row.

[00134] In Figure 4, positions 0 3 (column 0, row 3) and 4 1 (column 4, row 1) are not used and therefore are not specified. Position 1 2 occupies (straddles) columns 1 and 2 in row 2. Position 4 3 in column 4 straddles rows 3 and 4.

[00135] Straddling is described in “Creating Relative Placement Structures Containing Multiple Column or Row Positions”.

[00136] The following points can apply to creating a new group:

[00137] • A new group is empty. To add leaf cells, hierarchy (other groups), and keepouts to the group, use the `add_to_rp_group` command.

[00138] • Any number of groups can be created.

[00139] • Relative placement groups are persistently stored using the `write_milkyway` command and read using the `read_milkyway` command.

[00140] • The `create_rp_group` command returns a collection handle (identifier) to the relative placement groups that are created. If no objects were created, the empty string is returned.

[00141] To use the `create_rp_group` command, enter
`psyn_shell-xg-t> create_rp_group [options]`

To do this	Use this
Name the group	<code>group_name</code>
Specify the name of the design in which to create the new group. Omitting this option, defaults the design to the current design. Using this switch is good practice.	<code>-design</code>
Specify the number of columns for the group, expressed as a positive integer. The default is 1.	<code>-columns</code>
Specify the number of rows for the group, expressed as a positive integer. The default is 1.	<code>-rows</code>
Specify the default pin name to look up on a cell. By specifying <code>-pin_align_name</code> in an <code>add_to_rp_group</code> command, the value specified in <code>add_to_rp_group</code> overrides the value specified here. See “Aligning Relative Placement by Pins”.	<code>-pin_align_name</code>

To do this	Use this
Use the group for hierarchy instantiation. See “Defining Hierarchical Groups for Instantiation”.	-instance
Anchor the group on the x-axis or the y-axis but allow the group to slide in the other dimension. The values are in microns and the offset is relative to the chip’s origin. See “Anchoring Relative Placement Blocks at a Specified Location”.	-x_offset or -y_offset
Anchor the group on both the x-axis and y-axis by specifying the lower-left coordinates (anchor) for the group. The values are in micron and the offset is relative to the chip’s origin. See “Anchoring Relative Placement Blocks at a Specified Location”.	-x_offset and -y_offset

[00142] Example

[00143] To create the group named rp1 for designA having 1 column and 3 rows, enter

```
psyn_shell-xg-t> create_rp_group rp1 -design designA -columns 1 -rows 3
```

[00144] Renaming a Group

[00145] A group cannot be renamed directly. To rename a group, remove the group and create a new group that duplicates the removed group but has the new name. Alternatively, generate a script (using write_rp_group) and edit the name in the generated script. In other embodiments, the group can be renamed directly.

[00146] Adding Items to a Group

[00147] To add leaf cells, hierarchy groups, and keepouts to relative placement groups (created using create_rp_group), use the add_to_rp_group command.

[00148] When adding an item to a relative placement group, the following points can apply:

[00149] • The relative placement group in which the item is added must exist. In another embodiment, a default group is created.

[00150] • Switches identify whether the item added is a leaf cell (-leaf), hierarchical group (-hierarchy), or a keepout (-keepout).

[00151] The syntaxes for adding leaf cells, hierarchy groups, and keepouts differ. Table 3 provides a quick look up of the options allowed for each syntax.

[00152] • If an item already exists in the group at the given column and row location or if the item to be inserted is already positioned, an error message appears.

[00153] • The command returns a collection handle (identifier) to the relative placement groups in which the objects are added. If no objects are created, the empty string is returned.

[00154] Syntax for Adding a Leaf Cell

[00155] The syntax to add a leaf cell is

```
add_to_rp_group group_list -leaf cell_name
[-column col_number] [-row row_number]
[-pin_align_name pin_name]
[-orientation direction]
```

[00156] Syntax for Adding a Hierarchical Group

[00157] The syntax to add a hierarchical group is

```
add_to_rp_group group_list -hierarchy group_name
[-instance instance_name]
[-column col_number] [-row row_number]
```

[00158] Syntax for Adding a Keepout

[00159] The syntax to add a keepout is

```
add_to_rp_group group_list -keepout keepout_name
[-column column_number] [-row row_number]
[-width value] [-height value]
```

[00160] Options To Use to Add Items to Relative Placement Groups

[00161] Use appropriate options as shown previously in the syntaxes to add items to a relative placement group. The options used depend on the item to be added to the group. Table 3 provides a quick look up for the options available for each add_to_rp_group syntax.

To do this	Use this
List the relative placement group names in which to add items. The groups must be for the same design. In other embodiments, different designs are permitted.	group_list
Specify the column position in which to add the item (default is 0). Column positions start at 0, which is the leftmost column.	-column

To do this	Use this
Specify the row position in which to add the item (default is 0). Row positions start at 0, which is the bottom row.	-row
Add the named leaf cell. Each leaf cell added must exist in the gate-level netlist. (vs. -hierarchy or -keepout for the position specified). In other embodiments, a default cell is created.	-leaf
Add the named relative placement group for hierarchy inclusion. The group can be used one time in another group in the same design. See “Defining Hierarchical Groups for Inclusion”. (vs. -leaf or -keepout for the position specified).	-hierarchy
Specify the name of the instance on which to instantiate the given hierarchical relative placement group for hierarchy instantiation. A group can be instantiated more than once. See “Defining Hierarchical Groups for Instantiation”. Use -instance with -hierarchy. (vs. -leaf or -keepout for the position specified).	-hierarchy -instance
Add the named hard keepout. There is no keepout object so the name provided here is to reference the keepout after it is created. See “Adding Keepouts”.	-keepout
Specify the name of the pin to use for pin alignment of this cell with other cells in a group. If using -pin_align_name, the value specified here overrides a pin name provided with create_rp_group for the relative placement group to which it is being added. See “Aligning Relative Placement by Pins”.	-pin_align_name

To do this	Use this
Specify the placement orientation of a cell with respect to the group to which it is added. PDEF or DEF syntax can be used, as follows: – PDEF orientations: 0, 90, 180, 270, 0-mirror, 90-mirror, 180-mirror, or 270-mirror – DEF orientations: N, W, S, E, FN, FW, FS, or FE See “Specifying Orientation for Leaf Cells”.	-orientation
Specify the width of the keepout to add. If -width omitted, the keepout defaults to the width of the widest cell in the column in which the keepout is added. Use this option with -keepout and -height. See “Adding Keepouts”.	-width
Specify the height of the keepout to add. If -height omitted, the keepout defaults to the height of the tallest cell in the column in which the keepout is added. Use this option with -keepout and -width. See “Adding Keepouts”.	-height

[00162] Quick Lookup of Options for add_to_rp_group Syntaxes

[00163] Table 3 provides a quick lookup of the options available for the add_to_rp_group syntaxes.

[00164] Table 3 Quick Lookup of Options for add_to_rp_group Syntaxes

Option	Syntax	Leaf cell	Hierarchy for Inclusion	Hierarchy for instantiation	Keepout
group_list		X	X	X	X
-column		X	X	X	X
-row		X	X	X	X
-leaf		X			
-hierarchy			X	X	
-keepout					X
-pin_align_name		X			

Option	Syntax	Leaf cell	Hierarchy for Inclusion	Hierarchy for instantiation	Keepout
-orientation		X			
-instance				X	
-width					X
-height					X

[00165] Example

[00166] To find relative placement group `grp_ripple`, add leaf cell U2 to `grp_ripple`, then instantiate `grp_ripple` in the top group, enter

```
psyn_shell-xg-t> find rp_group grp_ripple
{ripple::grp_ripple}
psyn_shell-xg-t> add_to_rp_group grp_ripple -leaf carry_in_1
{ripple::grp_ripple}
psyn_shell-xg-t> add_to_rp_group top_group -hierarchy grp_ripple -instance U2
{example3::top_group}
```

[00167] Adding Hierarchical Groups

[00168] Hierarchical relative placement allows relative placement groups to be embedded within other relative placement groups. The embedded groups then are handled similarly to leaf cells. To add hierarchical groups, use the `add_to_rp_group` command with its `-hierarchy` or `-hierarchy` and `-instance` switches, depending on the type of hierarchical group wanted.

[00169] Hierarchical relative placement simplified expression of relative placement constraints. With hierarchical relative placement, providing relative placement information multiple times is unnecessary for a recurring pattern.

[00170] Benefits of Using Hierarchical Groups in Relative Placement

[00171] Various embodiments that implement hierarchical relative placement provide one or more of the following benefits:

[00172] 1) Allows organization of relative placement in a manner that is easier to maintain and understand. For example, the relative placement group can be created to parallel Verilog or VHDL organization.

[00173] 2) Allows reuse of a repeating placement pattern, for example, an adder.

[00174] 3) Can reduce the number of lines of relative placement information to be written.

[00175] 4) Allows integrating blocks.

[00176] 5) Provides flexibility for the wanted configuration.

[00177] Types of Hierarchical Relative Placement Group Usage

[00178] Hierarchical relative placement in different ways, depending on whether the relative placement group is used in the same design or in different designs:

[00179] Inclusion

[00180] Applies to a relative placement group in the same design as the group in which it is included. An included group is used one time in the same design.

[00181] See “Defining Hierarchical Groups for Inclusion”.

[00182] Instantiation

[00183] Applies to a relative placement group that is not from the design in which it is instantiated. An instantiated relative placement group can be used multiple times and in multiple places up to the number of times the design of the group is instantiated in the netlist.

[00184] See “Defining Hierarchical Groups for Instantiation”.

[00185] Important:

[00186] The syntaxes for creating the hierarchical group definitions for inclusion and for instantiation are the same except the use of -instance switch for instantiation.

[00187] Defining Hierarchical Groups for Inclusion

[00188] To specify that a group is a hierarchically included group, specify hierarchy by using the -hierarchy switch with the add_to_rp_group command.

[00189] When a group is included in a parent group, it is as if the group is directly embedded within the parent group. An included group can be used in another group of the same design one time. However, the new group that contains the included group can be further included in another group in the same design or instantiated in another group of a different design.

[00190] See the syntax provided in “Syntax for Adding a Hierarchical Group” and the options summary provided in Table 3.

[00191] Example

[00192] To include the relative placement group named rp3 as a hierarchical group for inclusion in group rp4, enter

```
psyn_shell-xg-t> add_to_rp_group rp4 -hierarchy rp3 -column 0 -row 0
```

[00193] The script in the following example defines the input for a hierarchical relative placement definition for inclusion. Groups rp1, rp2, rp3, and rp4 are all defined as being part of design top (shown in bold). The contents of groups rp1, rp2, and rp3 are treated as leaf cells when they are included in group rp4.

[00194] Example Hierarchical Relative Placement Definition for Inclusion

```
create_rp_group rp1 -design top -columns 2 -rows 1
```

```

add_to_rp_group rp1 -leaf U1 -column 0 -row 0
add_to_rp_group rp1 -leaf U4 -column 1 -row 0
create_rp_group rp2 -design top -columns 2 -rows 1
add_to_rp_group rp2 -leaf U2 -column 0 -row 0
add_to_rp_group rp2 -leaf U5 -column 1 -row 0
create_rp_group rp3 -design top -columns 2 -rows 1
add_to_rp_group rp3 -leaf U3 -column 0 -row 0
add_to_rp_group rp3 -leaf U6 -column 1 -row 0
create_rp_group rp4 -design top -columns 1 -rows 3
add_to_rp_group rp4 -hier rp1 -column 0 -row 0
add_to_rp_group rp4 -hier rp2 -column 0 -row 1
add_to_rp_group rp4 -hier rp3 -column 0 -row 2

```

[00195] In the above example,

[00196] • Groups rp1, rp2, and rp3 are each defined as having two columns and one row.

[00197] • Group rp4, in which groups rp1, rp2, and rp3 are included (each group used one time), is defined as having one column and three rows.

[00198] - Each included group is defined as a hierarchical subgroup (group rp1 as subgroup rp1, group rp2 as subgroup rp2, and group rp3 as subgroup rp3).

[00199] - Group rp4 can be further included as a hierarchical subgroup in another group in the same design.

[00200] The construction of the resulting hierarchical relative placement structure is shown in Figure 5.

[00201] Groups rp1, rp2, and rp3 are from the same design, top_design. They are included in group rp4, which can be further included one time in top_design.

[00202] Defining Hierarchical Groups for Instantiation

[00203] Specify that a group is a hierarchically instantiated group by specifying hierarchy plus an instance name with the add_to_rp_group command.

[00204] Instantiating a group is a useful way to replicate relative placement information across multiple instances of a design and to create relative placement relationships between those instances. An instantiated group can be used multiple times and in multiple places. For example, various embodiments use hierarchy instantiation for one or more of these cases:

[00205] 1) Multiple relative placement layouts are to be used for different instances of a design.

[00206] 2) Despite one layout, relative placement is to be specified between instances of that layout or between instances and other cells and groups.

[00207] The syntax for instantiation is the same as the syntax for inclusion but provides the -instance switch in addition to the -hierarchy switch. The -instance switch specifies the hierarchical cell upon which to instantiate the given hierarchical relative placement group. The instance is within the design of the group to which it is added and is an instance of the same design of the group being added hierarchically.

[00208] When uniquified, instantiated groups are dropped unless they are required for the newly uniquified group; that is, each instantiation will go to one uniquified design.

[00209] See the syntax provided in “Syntax for Adding a Hierarchical Group” and the options summary provided in Table 3.

[00210] Example

[00211] To instantiate the relative placement group named rp1 using a hierarchical cell instance named I1 in the relative placement group named rp2, enter

```
psyn_shell-xg-t> add_to_rp_group rp2 -hierarchy rp1
                    -instance I1 -column 0 -row 0
```

[00212] The script in the example below provides a definition for hierarchical relative placement for instantiation. Group rp1 is in the design pair_design (shown in bold) and defines leaf cells U1 and U2 as the group. Group rp2 is in the design mid_design (shown in bold) and instantiates three instances of group rp1 from pair_design, named I1, I2, and I3. Each instance is defined as a subgroup plus an instance name and each is treated as a leaf cell.

[00213] Example Definition for Hierarchical Relative Placement for Instantiation

```
create_rp_group rp1 -design pair_design -columns 2 -rows 1
    add_to_rp_group rp1 -leaf U1 -column 0 -row 0
    add_to_rp_group rp1 -leaf U2 -column 1 -row 0
create rp_group rp2 -design mid_design -columns 1 -rows 3
    add_to_rp_group rp2 -hier rp1 -instance I1 -column 0 -row 0
    add_to_rp_group rp2 -hier rp1 -instance I2 -column 0 -row 1
    add_to_rp_group rp2 -hier rp1 -instance I3 -column 0 -row 2
```

[00214] In the above example,

[00215] • Instances I1, I2, and I3 are hierarchical cells instantiating the design pair_design.

[00216] • Groups rp1 is defined as having two columns and one row and contains leaf cells U1 and U2.

[00217] • Group rp2, in which group rp1 is instantiated three times, is defined as having one column and three rows. Each instantiated group is defined as a hierarchical subgroup containing a named instance.

[00218] • Group rp2 is treated as a leaf cell, and can be used multiple times if it is further instantiated.

[00219] The construction of the resulting hierarchical relative placement block is shown in Figure 6.

[00220] Group rp1 belongs to the design pair_design. It is instantiated three times in group rp2, which can be further instantiated in different designs.

[00221] Ungrouping Hierarchical Relative Placement

[00222] The ungroup command changes hierarchical relative placement structure.

[00223] After using ungroup, hierarchical relative placement instantiation is converted to hierarchical relative placement inclusion because the design is flattened and all the groups are now of the same design. Instantiation of hierarchical modules no longer exists.

[00224] Relative placement groups affected by an ungroup command are renamed to show the path to the group before flattening followed by a slash (/) and the original group name. If this results in a name collision, a numbered suffix is added to create a unique name. For example, rp2 rp1(I3) 0 2 becomes rp2 I3/rp1 0 2 after ungrouping.

[00225] Using the hierarchical block shown in Figure 6, the relative placement definition is now as shown in the example below. After ungroup -flatten -all, the resulting ungrouped hierarchical placement block is as shown in Figure 7.

[00226] Example Hierarchical Relative Placement Changed by the ungroup Command

```
create_rp_group I1/rp1 -design mid_design -columns 2 -rows 1
    I1/rp1 -leaf I1/U1 -column 0 -row 0
    I1/rp1 -leaf I1/U2 -column 1 -row 0
create_rp_group I2/rp1 -design mid_design -columns 2 -rows 1
    I2/rp1 -leaf I2/U1 -column 0 -row 0
    I2/rp1 -leaf I2/U2 -column 1 -row 0
create_rp_group I3/rp1 -design mid_design -columns 2 -rows 1
    I3/rp1 -leaf I3/U1 -column 0 -row 0
    I3/rp1 -leaf I3/U2 -column 1 -row 0
create_rp_group rp2 -design mid_design -columns 1 -rows 3
    rp2 -hierarchy I1/rp1 -column 0 -row 0
    rp2 -hierarchy I2/rp1 -column 0 -row 1
```

```
rp2 -hierarchy I3/rp1 -column 0 -row 2
```

[00227] Uniquifying Hierarchical Relative Placement

[00228] The `uniquify` command can change each instantiation of hierarchical relative placement structure.

[00229] For example, `uniquifying`

```
group grp_top top 1 2
    hier grp_ripple(U1) 0 0
    hier grp_ripple(U2) 0 1
group grp_ripple ripple
[ ... ]
```

[00230] results in

```
group grp_top top 1 2
    hier grp_ripple_1(U1) 0 0
    hier grp_ripple_2(U2) 0 1
group grp_ripple_1 ripple_1
group grp_ripple_2 ripple_2
```

[00231] Adding Keepouts

[00232] Hard keepouts can be specified within relative placement blocks. To do this, use the `add_to_rp_group` command with its `-keepout` switch.

[00233] When defining keepouts, the one or more of the following points can apply:

[00234] • Keepouts are not objects. A name is to be provided for reference. IN other embodiments, object keepouts are created.

[00235] • The width and height of a keepout can be specified.

[00236] - The unit of width for a keepout is the number of placement sites. If the width is not specified, the default width is the width of the widest cell in that column.

[00237] - The unit of height for a keepout is one row. If the height is not specified, the default height is the height of the tallest cell in that row.

[00238] See the syntax provided in “Syntax for Adding a Keepout” and the options summary provided in Table 3.

[00239] Example

[00240] To create the hard keepout named `gap1` shown in Figure 8, enter

```
psyn_shell-xg-t> add_to_rp_group misc
    -keepout gap1
    -column 0 -row 2
```

-width 15 -height 1

[00241] Figure 8 shows a relative placement block containing keepouts 800 (named gap1 ... gap5 in this example). The input to define the keepouts 800 is provided in the example below, following the figure.

[00242] The script in the example below provides the definition for the relative placement block containing keepouts shown in Figure 8.

[00243] Example Definition for Relative Placement Input for Defining Keepouts

```
create_rp_group misc -design top -columns 5 -rows 4
  add_to_rp_group misc -leaf U1 -column 0 -row 0
  add_to_rp_group misc -leaf U3 -column 0 -row 1
  add_to_rp_group misc -keepout gap1 -column 0 -row 2 -width 15
    -height 1
  add_to_rp_group misc -leaf U4 -column 0 -row 3
  add_to_rp_group misc -leaf U2 -column 1 -row 0
  add_to_rp_group misc -keepout gap2 -column 1 -row 1 -width 15
    -height 1
  add_to_rp_group misc -keepout gap3 -column 2 -row 1 -width 10
    -height 1
  add_to_rp_group misc -leaf U5 -column 3 -row 0
  add_to_rp_group misc -leaf U6 -column 3 -row 1
  add_to_rp_group misc -leaf U7 -column 3 -row 2
  add_to_rp_group misc -keepout gap4 -column 3 -row 2 -width 5 -height 1
  add_to_rp_group misc -keepout gap5 -column 3 -row 3 -width 20
    -height 1
  add_to_rp_group misc -leaf U8 -column 4 -row 0
  add_to_rp_group misc -leaf U9 -column 4 -row 1
```

[00244] Creating Relative Placement Structures Containing Multiple Column or Row Positions

[00245] A cell can occupy multiple column positions or multiple row positions, which is known as straddling. To define straddling, use the inclusion hierarchical relative placement syntax (see “Defining Hierarchical Groups for Inclusion”). When a group is an included group, it can be used once in the design in which it is defined. However, the new group in which it is included can be included or instantiated in another group.

[00246] Figure 9 shows a relative placement group in which cells straddle columns (instance U2 901) and rows (instance U7 902).

[00247] The script in the example below provides the definition for the relative placement block shown in Figure 9.

[00248] To construct the hierarchy needed for straddling, the leaf cell groups are defined for rp1, rp2 (the cell that straddles columns 0 and 1), and rp3, then define group rp4 to contain groups rp1, rp2, and rp3. Finally, rp5 is defined to contain group rp4 and leaf cell U7 (the cell that straddles rows 0, 1, and 2).

[00249] Example Definition for Relative Placement Input for Hierarchical Placement With Straddling

```
create_rp_group rp1 -design top -columns 2 -rows 1
    add_to_rp_group rp1 -leaf U1 -column 0 -row 0
    add_to_rp_group rp1 -leaf U4 -column 1 -row 0
create_rp_group rp2 -design top -columns 1 -rows 1
    add_to_rp_group rp2 -leaf U2 -column 0 -row 0
create_rp_group rp3 -design top -columns 2 -rows 1
    add_to_rp_group rp3 -leaf U3 -column 0 -row 0
    add_to_rp_group rp3 -leaf U6 -column 1 -row 0
create_rp_group rp4 -design top -columns 1 -rows 3
    add_to_rp_group rp4 -hier rp1 -column 0 -row 0
    add_to_rp_group rp4 -hier rp2 -column 0 -row 1
    add_to_rp_group rp4 -hier rp3 -column 0 -row 2
create_rp_group rp5 -design top -columns 2 -rows 1
    add_to_rp_group rp5 -hier rp4 -column 0 -row 0
    add_to_rp_group rp5 -leaf U7 -column 1 -row 0
```

[00250] Figure 10 shows the construction of the hierarchy defined in the example above.

[00251] Specifying Orientation for Leaf Cells

[00252] By default, the placement, routing, and optimization tool does orientation optimization (automatic orientation) for cells in relative placement groups but orientation can be specified for cells on a per-cell basis, use a mix of user-specified orientation and automatic orientation, or disable orientation on cells in relative placement groups. You cannot specify orientation for a group. In some embodiments, specifying orientation for a group specifies that orientation for all cells of the group.

[00253] If an orientation is not specified for a cell, by default, the tool uses either orientation optimization or the default orientation for the cell. Orientation optimization can flip a cell from its default orientation to improve wire length.

[00254] To specify orientation for leaf cells, use the `add_to_rp_group` command with its `-orientation` switch and the syntax for defining a leaf cell. In addition, direct the placement, routing, and optimization tool is to be directed regarding orientation optimization.

[00255] When specifying orientation, one or more of the following points can apply:

[00256] • Orientation specified has precedence over orientation optimization and default orientation.

[00257] • If an orientation that is not valid is specified, that orientation is ignored and a valid orientation is used.

[00258] • Specifying both pin alignment and orientation in the same invocation might be contradictory. Although every attempt is made to honor such a request, honoring both might not be possible. In this case, the orientation specification takes precedence over the pin alignment specification.

[00259] • If orientation is not specified for a cell and automatic orientation is done, pin alignment is honored.

[00260] The syntax is

```
add_to_rp_group group_list -leaf instance_name
                    -column col_number -row row_number -orientation direction
```

[00261] For syntax details, see “Adding Items to a Group”.

[00262] Directing Orientation Optimization

[00263] Orientation optimization can flip a cell to improve relative placement wire length, thereby improving QoR for the design. Orientation optimization is enabled by default.

[00264] The `physopt_rp_enable_orient_opt` variable controls whether orientation optimization is enabled (default true). Orientation optimization is enabled or disabled according to whether to specify the orientation for some cells or disable orientation optimization.

[00265] Specifying a Mix of User-Specified Orientation and Automatic Orientation

[00266] Orientation can be specified for some cells in a group and automatic orientation allowed for the other cells. To do this, ensure that the `physopt_rp_enable_orient_opt` variable is set to true (the default).

[00267] This ensures that orientations specified are respected and automatic orientation is done for the other cells.

[00268] Disabling Orientation Optimization

[00269] Orientation optimization can be disabled by setting `physopt_rp_enable_orient_opt` to false (default is true), for example, when pin alignment is to have precedence.

[00270] When this variable is set to false, the specified orientation is respected if the orientation is valid. If no user-specified orientation exists, a default valid orientation is chosen.

[00271] Specifying Orientation and Pin Alignment

[00272] Both orientation and pin alignment can be specified in the same invocation but doing this might be contradictory.

[00273] When used with pin alignment, in various embodiments the priorities for orientation are as follows, in this order:

[00274] 1. User-specified orientation

[00275] When used with pin alignment, orientation has precedence.

[00276] 2. Orientation optimization

[00277] If orientation is not specified for a cell and orientation optimization is done, pin alignment is honored.

[00278] 3. Default orientation

[00279] When used with pin alignment, pin alignment has precedence.

[00280] Other embodiments remove, add to, or rearrange the above priorities.

[00281] Figure 11 shows orientation optimization used with pin alignment, in particular pin A 1100. In such a case, both orientation and pin alignment are honored. (Not all leaf cells listed in the example that follows the figure are shown in the figure.)

[00282] The example below provides the definition for the relative placement shown in Figure 11.

[00283] Example Orientation Optimization Used With Pin Alignment

```
create_rp_group misc1 -design block1 -columns 3 -rows 10 -pin_alignment A
    add-to_rp_group misc1 -leaf I3 -column 0 -row 0 -orientation N
    add-to_rp_group misc1 -leaf I4 -column 0 -row 1 -orientation FN
    add-to_rp_group misc1 -leaf I5 -column 0 -row 2 -orientation N
    add-to_rp_group misc1 -leaf I6 -column 0 -row 3
    add-to_rp_group misc1 -leaf I7 -column 0 -row 4
    add-to_rp_group misc1 -leaf I8 -column 0 -row 5
```

[00284] Writing Relative Placement Information to a Script File

[00285] Specified relative placement groups can be written to a named file, creating a Tcl-format script for recreating relative placement groups and their items on the same design. To do this, use the `write_rp_group` command.

[00286] The command returns a collection handle (identifier) of relative placement groups written out. If no objects were written, the empty string is returned.

[00287] To use the `write_rp_group` command, enter `psyn_shell-xg-t> write_rp_group [options]`

To do this	Use this
List the groups to write to the script. (vs. using <code>-all</code>).	<code>group_list</code>
Write all the relative placement groups to the script. (vs. using a group list or <code>-hierarchy</code>).	<code>-all</code>
Write all the relative placement groups within the hierarchy of the relative placement groups. By omitting this option, subgroups are not written.	<code>-hierarchy</code>
Disable line splitting when information exceeds the column width.	<code>-nosplit</code>
Write the script to the specified file. By omitting this option, the information is written to the screen.	<code>-output</code>

[00288] Example

[00289] To save all the relative placement groups to disk, remove the information from the design, then recreate the information on the design, enter

```
psyn_shell-xg-t> find rp_group
{mul::grp_mul ripple::grp_ripple example3::top_group}
psyn_shell-xg-t> write_rp_group -all -output my_groups.tcl
1
psyn_shell-xg-t> remove_rp_group -all -quiet
1
psyn_shell-xg-t> find rp_group
Error: Can't find objects matching '*'. (UID-109)
psyn_shell-xg-t> source my_groups.tcl
```



```
{example3::top_group}
psyn_shell-xg-t> find rp_group
{example3::top_group ripple::grp_ripple mul::grp_mul}
```

[00290] Aligning Relative Placement by Pins

[00291] Columns can be aligned by pins instead of by the lower-left corner (the default). This capability increases the probability of straight routes and can result in less congestion, lower power, and lower routing resources by eliminating vias.

[00292] To align a group by pins, use the `create_rp_group` command with its `-pin_align_name` switch.

[00293] When aligning by pins, one or more of the following points can apply:

[00294] • When specifying a pin name, the tool determines the location for that pin in cells in the column, then aligns the column based on the pin locations.

[00295] • If cells in a column do not have the pin specified, the column is aligned as follows:

[00296] - If some cells in a column do not have the pins specified, those cells are aligned with a default position (e.g., the lower-left corner) and an information message appears.

[00297] - If no cells in a column have the pins specified, the cells are aligned with a default position (e.g., the lower-left corner) and a warning appears.

[00298] • Aligning by pins can result in empty space between columns.

[00299] • Both pin alignment and orientation can be specified in the same invocation but doing this might be contradictory. Although every attempt is made to honor such a request, honoring both might not be possible. In this case, the orientation specification takes precedence over the pin alignment specification.

[00300] • The widest cell in the column determines the width of the column.

[00301] Figure 12 shows a relative placement group aligned by pins.

[00302] The script in the example below defines the relative placement group shown in Figure 12, which is aligned by pin A 1201.

[00303] Example Definition for Relative Placement Group Aligned by Pins

```
create_rp_group rp1 -design pair_design -columns 1 -rows 4 -pin_align_name A
    add_to_rp_group rp1 -leaf U1 -column 0 -row 0
    add_to_rp_group rp1 -leaf U2 -column 0 -row 1
    add_to_rp_group rp1 -leaf U3 -column 0 -row 2
    add_to_rp_group rp1 -leaf U4 -column 0 -row 3
```

[00304] A column can be aligned within a placement group by a specified pin and align cells within the column by a different pin as shown in Figure 13, with pin A 1301 and pin B 1302.

The alignment pin name specified for particular cells in the column overrides the alignment pin name specified for the group.

[00305] A set of cells can be specified to align over specified pins. For example, pins A and B can be aligned in a group by specifying a different pin alignment name for some cells.

[00306] The script in the example below defines the relative placement group shown in Figure 13. In the example, the group misc1 is aligned by pin A and instances I5 and I6 within the group are aligned by pin B, overriding the group pin alignment name A for those instances.

[00307] Example Definition to Align a Group and Leaf Cells by Pins

```
create_rp_group misc1 -design block1 -columns 3 -rows 10 -pin_align_name A
  add_to_rp_group misc1 -leaf I3 -column 0 -row 0
  add_to_rp_group misc1 -leaf I4 -column 0 -row 1
  add_to_rp_group misc1 -leaf I5 -column 0 -row 2 -pin_align_name B
  add_to_rp_group misc1 -leaf I6 -column 0 -row 3 -pin_align_name B
  add_to_rp_group misc1 -leaf I7 -column 0 -row 4
  add_to_rp_group misc1 -leaf I8 -column 0 -row 5
```

[00308] Figure 14 shows a relative placement block that contains a group aligned by pins, in particular pin CLK 1401 —the column named bank1 (col 0). It is included in the group named final. Group final can also be used further for instantiation or inclusion in another group.

[00309] The script in the example below provides the definition for the relative placement block shown in Figure 14.

[00310] Example Definition for Hierarchical Relative Placement Block With Column Aligned by Pins

```
create_rp_group bank1 -design top -columns 1 -rows 4 -pin_name clk
  add_to_rp_group bank1 -leaf U1 -column 0 -row 0
  add_to_rp_group bank1 -leaf U2 -column 0 -row 1
  add_to_rp_group bank1 -leaf U3 -column 0 -row 2
  add_to_rp_group bank1 -leaf U4 -column 0 -row 3
create_rp_group bank2 -design top -columns 1 -rows 2
  add_to_rp_group bank2 -leaf U5 -column 0 -row 0
  add_to_rp_group bank2 -leaf U6 -column 0 -row 1
create rp_group bank4 -design top -columns 1 -rows 4
  add_to_rp_group bank4 -leaf U19 -column 0 -row 0
  ...
  add_to_rp_group bank4 -leaf U22 -column 0 -row 3
```

```

create_rp_group comb1 -design top -columns 3 -rows 1
    add_to_rp_group comb1 -leaf U7 -column 0 -row 0
    add_to_rp_group comb1 -leaf U8 -column 1 -row 0
    add_to_rp_group comb1 -leaf U9 -column 2 -row 0
create_rp_group comb2 -design top -columns 3 -rows 1
    add_to_rp_group comb2 -leaf U10 -column 0 -row 0
    add_to_rp_group comb2 -leaf U11 -column 1 -row 0
    add_to_rp_group comb2 -leaf U12 -column 2 -row 0
create_rp_group comb3 -design top -columns 3 -rows 1
    add_to_rp_group comb3 -leaf U13 -column 0 -row 0
    add_to_rp_group comb3 -leaf U14 -column 1 -row 0
    add_to_rp_group comb3 -leaf U15 -column 2 -row 0
create_rp_group comb4 -design top -columns 3 -rows 1
    add_to_rp_group comb4 -leaf U16 -column 0 -row 0
    add_to_rp_group comb4 -leaf U17 -column 1 -row 0
    add_to_rp_group comb4 -leaf U18 -column 2 -row 0
create_rp_group bank3 -design top -columns 1 -rows 4
    add_to_rp_group bank3 -hierarchy comb1 -column 0 -row 0
    add_to_rp_group bank3 -hierarchy comb2 -column 0 -row 1
    ...
create_rp_group final -design top -columns 4 -rows 1
    add_to_rp_group final -hierarchy bank1 -column 0 -row 0
    add_to_rp_group final -hierarchy bank2 -column 1 -row 0
    add_to_rp_group final -hierarchy bank3 -column 2 -row 0
    add_to_rp_group final -hierarchy bank4 -column 3 -row 0

```

[00311] Anchoring Relative Placement Blocks at a Specified Location

[00312] A single relative placement block can be anchored at a location specified. Anchoring allows controlled placement of the relative placement block with respect to other relative placement blocks, macros, or to the edges and origin of the core area.

[00313] To anchor a relative placement group, use the `create_rp_group` command with its `-x_offset` and `-y_offset` switches.

[00314] When specifying an anchor point, one or more of the following points can apply:

[00315] • Provide anchor points for top level groups. Anchor points are allowed at the top level.

[00316] • Both the x- and y-coordinates or either the x- or y-coordinate can be specified. Specifying one coordinate as fixed allows the unspecified coordinate to slide. The offset is an integer, in microns, relative to the chip's origin.

[00317] • If an anchor point outside the design boundary is specified, relative placement alignment for the block fails, a warning appears, and the cells are clustered inside the boundary.

[00318] • If an anchor point is specified for a group that is not a top-level group or that causes placement that is not valid, a warning appears and relative placement continues.

[00319] Figure 15 shows a relative placement block anchored at both the x-coordinate and the y-coordinate.

[00320] The script in the example below provides the definition for anchoring relative placement block misc1 in block 1 at both x-coordinate 100 and y-coordinate 100. (In both the figure and the example, not all rows are shown.)

[00321] Example Definition for Anchoring a Group Using Two Coordinates

```
create_rp_group misc1 -design block1 -columns 3 -rows 10
    -x_offset 100 -y_offset 100
add_to_rp_group misc1 -leaf I30 -column 0 -row 0
add_to_rp_group misc1 -leaf I31 -column 0 -row 1
add_to_rp_group misc1 -leaf I32 -column 0 -row 2
add_to_rp_group misc1 -leaf I33 -column 0 -row 3
add_to_rp_group misc1 -leaf I34 -column 0 -row 4
add_to_rp_group misc1 -leaf I35 -column 0 -row 5
...
```

[00322] Figure 16 shows 12 relative placement blocks aligned and anchored vertically at four coordinates. Blocks 1, 2, and 3 1601 have `-x_offset 100`. Blocks 4, 5, and 6 1602 have `-x_offset 200`. Blocks 7, 8, and 9 1603 have `-x_offset 300`. Blocks 10, 11, and 12 1604 have `-x_offset 400`.

[00323] The script in the example below defines the locations of the 12 vertically aligned and anchored relative placement blocks shown in Figure 16. For brevity, not every group is listed in the example.

[00324] Example Definitions for Locations of Vertically Aligned and Anchored Blocks

```
create_rp_group block1 -design misc1 -columns 3 -rows 10 -x_offset 100
create_rp_group block2 -design misc1 -columns 3 -rows 10 -x_offset 100
create_rp_group block3 -design misc1 -columns 3 -rows 10 -x_offset 100
```

```

create_rp_group block4 -design misc1 -columns 3 -rows 10 -x_offset 200
create_rp_group block5 -design misc1 -columns 3 -rows 10 -x_offset 200
create_rp_group block6 -design misc1 -columns 3 -rows 10 -x_offset 200
...
create_rp_group block12 -design misc1 -columns 3 -rows 10 -x_offset 400

```

[00325] Using Compression to Remove Empty Space in a Relative Placement Group

[00326] By default, construction for relative placement aligns cells from their bottom-left corner. Compression removes empty space in rows to create a more compact structure. The compressed columns are no longer aligned and utilization is higher in the area of the compressed cells.

[00327] If compression is needed, use hierarchical relative placement to construct the pattern, using the syntax for hierarchical inclusion.

[00328] Figure 17 shows the same cells aligned without compression 1701 and with compression 1702. The cells are bottom-left aligned.

[00329] Alternatively, compression can be accomplished by using bit-stack placement. Set the variable `physopt_bit_stacked_placement` to true (the default is false). Setting this variable to true causes the empty space to be removed, compressing the group as shown in Figure 17. The columns are no longer aligned and utilization is higher.

[00330] Relative Placement in a Design Containing Obstructions

[00331] During placement, relative placement groups can avoid placement keepouts (obstructions) that are defined in the PDEF file or created by a the placement, routing, and optimization tool keepout command (`create_placement_keepout`, `create_wiring_keepout`). A relative placement group can be broken into pieces that straddle obstructions.

[00332] Figure 18 shows the placement of relative placement cells in a design containing keepouts 1801 that were either defined in the PDEF file or created by a the placement, routing, and optimization tool keepout command. Rows 0 and 2 and column 5 are placed to avoid the keepouts but relative placement alignment is maintained.

[00333] Converting rp_reader Syntax to Tcl Syntax

[00334] Use the following transformations to convert existing `rp_reader` text files to Tcl syntax to use within the placement, routing, and optimization tool:

[00335] • Change the keyword `group` to the `create_rp_group` command

[00336] • Insert the `add_to_rp_group` command before each item in a group

[00337] • Change the keyword `keepout` to `-keepout`

[00338] • Change the keyword `hierarchy` to `-hierarchy`

- [00339] • Change the keyword leaf to -leaf
- [00340] • Insert the -design switch before the design name when creating a relative placement group
- [00341] • Insert the -column and -row switches in front of those values
- [00342] • Insert the -width and -height switches in front of those values
- [00343] Alternatively, the following command can be used that runs a script to do the conversion:

```
rp_reader dbfile out.tcl -tcl_export
```

[00344] The following tables show the rp_reader file format elements for groups, leaf cells, hierarchy groups, and keepouts.

[00345] Group

group	misc	top	9	10
keyword	group name	design name	number of columns	number of rows

[00346] Leaf cell

custom	leaf	U0	0	0
group name	keyword	instance name	column position	row position

[00347] Hierarchy group for inclusion

rp4	hier	rp1	0	0
group name	keyword	subgroup name	column position	row position

[00348] Hierarchy group for instantiation

rp2	hier	rp1	(U3)	0	0
group name	keyword	subgroup name	instance name	column position	row position

[00349] Keepout

misc	keep	gap4	3	2	5	1
------	------	------	---	---	---	---

group name	keyword	keepout name	column position	row position	width	height
------------	---------	--------------	-----------------	--------------	-------	--------

[00350] Figure 19 is a simplified block diagram of a computer system 1910 suitable for use with embodiments of the technology. Computer system 1910 typically includes at least one processor 1914 which communicates with a number of peripheral devices via bus subsystem 1912. These peripheral devices may include a storage subsystem 1924, comprising a memory subsystem 1926 and a file storage subsystem 1928, user interface input devices 1922, user interface output devices 1920, and a network interface subsystem 1916. The input and output devices allow user interaction with computer system 1910. Network interface subsystem 1916 provides an interface to outside networks, including an interface to communication network 1918, and is coupled via communication network 1918 to corresponding interface devices in other computer systems. Communication network 1918 may comprise many interconnected computer systems and communication links. These communication links may be wireline links, optical links, wireless links, or any other mechanisms for communication of information. While in one embodiment, communication network 1918 is the Internet, in other embodiments, communication network 1918 may be any suitable computer network.

[00351] User interface input devices 1922 may include a keyboard, pointing devices such as a mouse, trackball, touchpad, or graphics tablet, a scanner, a touchscreen incorporated into the display, audio input devices such as voice recognition systems, microphones, and other types of input devices. In general, use of the term "input device" is intended to include all possible types of devices and ways to input information into computer system 1910 or onto computer network 1918.

[00352] User interface output devices 1920 may include a display subsystem, a printer, a fax machine, or non-visual displays such as audio output devices. The display subsystem may include a cathode ray tube (CRT), a flat-panel device such as a liquid crystal display (LCD), a projection device, or some other mechanism for creating a visible image. The display subsystem may also provide non-visual display such as via audio output devices. In general, use of the term "output device" is intended to include all possible types of devices and ways to output information from computer system 1910 to the user or to another machine or computer system.

[00353] Storage subsystem 1924 stores the basic programming and data constructs that provide the functionality of certain embodiments. For example, the various modules implementing the functionality of certain embodiments may be stored in storage subsystem 1924. These software modules are generally executed by processor 1914.

[00354] Memory subsystem 1926 typically includes a number of memories including a main random access memory (RAM) 1930 for storage of instructions and data during program execution and a read only memory (ROM) 1932 in which fixed instructions are stored. File storage subsystem 1928 provides persistent storage for program and data files, and may include a hard disk drive, a floppy disk drive along with associated removable media, a CD-ROM drive, an optical drive, or removable media cartridges. The databases and modules implementing the functionality of certain embodiments may be stored by file storage subsystem 1928.

[00355] Bus subsystem 1912 provides a mechanism for letting the various components and subsystems of computer system 1910 communicate with each other as intended. Although bus subsystem 1912 is shown schematically as a single bus, alternative embodiments of the bus subsystem may use multiple busses.

[00356] Computer readable medium 1940 can be a medium associated with file storage subsystem 1928, and/or with network interface 1916. The computer readable medium can be a hard disk, a floppy disk, a CD-ROM, an optical medium, removable media cartridge, or electromagnetic wave. The computer readable medium 1940 is shown storing a circuit design 1980 created with the described technology. Also shown is a circuit 1990 created with the described technology.

[00357] Computer system 1910 itself can be of varying types including a personal computer, a portable computer, a workstation, a computer terminal, a network computer, a television, a mainframe, or any other data processing system or user device. Due to the ever-changing nature of computers and networks, the description of computer system 1910 depicted in Figure 19 is intended only as a specific example for purposes of illustrating the preferred embodiments. Many other configurations of computer system 1910 are possible having more or less components than the computer system depicted in Figure 19.

[00358] Automatic relative placement rules at RTL-level

[00359] Relative placement rules can be generated the RTL-level. RP takes advantage of inherent structure at the RTL-level of behavioral description, in addition to at the netlist cell level.

[00360] When relative placement rules can be generated at the RTL-level, the RP constraints are not required to be specific to the netlist, as the RP constraints are not required to be tied to the instance names of the cells in the netlist. Thus, every time a new netlist is synthesized, and the netlist has different instance names from a previously synthesized netlist despite functionally identical designs, the RP constraints are not invalidated and need not be re-written to reference

new cell instance names. This process is easily repeatable. RP constraints at the RTL-level are portable even when a new netlist is created through additional synthesis.

[00361] When relative placement rules can be generated at the RTL-level, then corresponding RP constraints at the cell instance level do not have to be written. This saves time, because writing RP constraints at the cell instance level is a very detailed and tedious task.

[00362] This technology focuses on RP specification on high level RTL constructs and subsequent automatic cell level RP generation from the specification. It frees the user from writing the cell level RP constraints and rewriting them when the design is re-synthesized. The solution also has the full implementation flow support from RTL synthesis to place and route.

[00363] In one example design flow, an RTL hardware description is processed by a synthesis tool such as Synopsys Design Compiler into a netlist. The synthesis tool automatically creates RTL-level RP rules. When the synthesis tool creates the netlist, the corresponding netlist-level RP rules are automatically created based on the RTL-level RP rules. A place and route and optimization tool such as Synopsys IC Compiler then generates the placed, routed, and optimized design from the netlist and the netlist-level RP rules. Generated netlist-level RP rules are automatically updated reflecting name changes on composing cells when design hierarchy is being ungrouped, uniquified, change_named or change_linked.

[00364] The RP constraints are propagated to synthesis and place and route tools such as DCT and ICC.

[00365] Automatic relative placement for clock trees

[00366] The application of automatic relative placement to clock trees helps to prevent overdesign from adding too many levels of buffers to the clock network, and helps to prevent oversizing the drivers of the buffers. Because overdesign is reduced, the clock tree can handle higher fanouts from the clock drivers for relative placement.

[00367] Figure 20 is a flow diagram illustrating an exemplary process of the placement, routing, and optimization tool with clock tree synthesis clustering being performed during placement.

[00368] The process flow of Figure 20 is similar to the process of Figure 2, and adds clock tree synthesis clustering during placement. In 2002, coarse placement is performed on the netlist. In 2004, during placement, clock tree synthesis is applied to cluster leaf-level clock flip-flops.

[00369] In 2006, during placement, relative placement groups are automatically defined based on the results from the clock tree synthesis clustering of leaf-level clock flip-flops. There are four cases shown – the four combinations of netlists with and integrated clock gating, and clock

tree buffers added or not added. In 2006A, the netlist is without integrated clock gating, and buffers are added before each of the relative placement groups. Clock buffers amplify clock signals degraded by interconnect impedance, and isolate clock nets from upstream load impedance of the clock tree. Because buffers are added, the nets are broken between the clock and the relative placement groups. In 2006B, the netlist is without integrated clock gating, and buffers are not added before each of the relative placement groups. Because buffers are not added, the nets are not broken between the clock and the relative placement groups. In 2006C, the netlist is with integrated clock gating, and integrated clock gating is added in each of the relative placement groups. In 2006D, the netlist is with integrated clock gating, and integrated clock gating is not added in each of the relative placement groups, such that the integrated clock gating is freely movable by the placer.

[00370] In 2009, incremental placement of relative placement blocks, and detailed placement of non-relative placement cells, is performed. In 2018, physical optimization of cells is performed. In 2020, relative placement constraints are applied. In 2030, clock tree synthesis is applied to build the complete clock tree(s).

[00371] Figure 21 is a flow diagram illustrating another exemplary process of the placement, routing, and optimization tool with clock tree synthesis clustering being performed during placement.

[00372] In 2101, the annotated netlist is preprocessed for relative placement annotation. Data structures are created to carry relative placement information. In 2102, clock drivers such as integrated clock gating are scanned in the netlist (or user input received for a given clock net, clock pin, or clock name), etc., and clock sinks for a given clock object (integrated clock gating, clock pin, clock name, clock pin, etc.) are collected for post-initial placement. In 2104, user clock tree synthesis constraints are read in, such as clock tree references. Clock tree constraints are specified early for relative placement, rather than waiting for post-placement full clock tree synthesis.

[00373] Clock tree constraints are listed as follows, with a description of constraint. None, one, or more of the clock tree constraints can be in effect. The scope of each constraint can be global or per clock. Various constraints specify: clock trees that the options apply to; maximum capacitance constraint; maximum fanout constraint; maximum transition time constraint; maximum skew goal; minimum insertion delay goal; maximum number of clock tree levels; preferred layers for clock tree routing; nondefault routing rule used for clock tree routing; whether default routing rules are used for the clock tree levels closest to the clock sink; whether to enable/disable boundary cell insertion; whether to cluster based on minimum wire length;

whether to cluster based on on-chip variation; whether to enable/disable logic-level balancing; whether to enable/disable buffer relocation during optimization; whether to enable/disable buffer sizing during optimization; whether to enable/disable delay insertion during optimization; whether to enable/disable gate relocation during optimization; whether to enable/disable gate sizing during optimization; the clock configuration file to read; and the name of the clock configuration file that is written after clock tree synthesis.

[00374] In 2106, clock tree synthesis clustering is performed. Prior to clustering, pre-existing relative placement cells, invalid relative placement objects etc. are filtered out of list of flip-flops to be clustered. Responsive to calling the compile clock tree clustering algorithm, the clock tree synthesis clusters are returned. Multiple cluster handling includes checking all elements in a cluster to verify that they belong to the same hierarchy. If all elements do not belong to the same hierarchy, then a relative placement group is not created from the cluster.

[00375] In 2108, clusters from the clock tree synthesis clustering are processed, and relative placement groups are formed from the clusters; geometric compression is performed; and the shapes of relative placement groups is automatically determined. Example geometric compression details follow. Existing RP elements are filtered from collection. Sorting is performed based on X location of each cell (alternatively, Y location). The number of rows and columns is automatically determined based on the total number of elements. An example of this determination follows: $\text{MaxRows} = f(\text{RPShape}, \text{userinput})$; $\text{FormFactor} = f(\text{Macflops}, \text{MaxRows})$; $\text{NumRows} = f(\text{FormFactor}, \text{NumFlops})$; $\text{NumCols} = f(\text{Numflops}, \text{clockdriver}, \text{NumRows})$. Finally, elements are sorted within each column based on Y location of each cell (alternatively, X location).

[00376] In 2110, integrated clock gating is added, or clock drivers are added to the clusters from clock tree synthesis clustering. Nets are broken as needed to make such additions of the integrated clock gating and the clock drivers. For example, if a buffer needs to be inserted, then the net is broken, the buffer is created, and the buffer is connected. In another example, clock drivers of correct size are chosen and inserted. In 2112, relative placement options are set for each relative placement group. Examples of relative placement options are bottom left alignment (alternatively bottom right, top right, top left), pin alignment (such as clock pin), orientation (such as to minimize wire crossing within a relative placement group), X offset and/or Y offset (in case of anchored locations, anchor of RP group derived based on initial locations of flip-flops and ICG, and center of gravity used to determine X and/or Y offsets), routing and optimization options, move values for RP groups (how much a group can move while doing overlap removal, etc. In 2114, the coarse placement is refined. In the next pass of

coarse placement, the relative placement groups are placed. Relative placement groups are legalized respecting all automatically generated or manually specified relative placement constraints. In 2116, optimization occurs. In 2118, size is fixed/marked for the relative placement groups for clock tree synthesis. In 2120, the full clock tree synthesis is performed.

[00377] While the present invention is disclosed by reference to the embodiments and examples detailed above, it is to be understood that these examples are intended in an illustrative rather than in a limiting sense. It is contemplated that modifications and combinations will readily occur to those skilled in the art, which modifications and combinations will be within the spirit of the invention and the scope of the following claims. What is claimed is:

CLAIMS

- 1 1. A method of circuit design with a computer system, comprising:
2 generating with the computer system a placed, routed, and optimized circuit
3 design, including:
4 guiding coarse placement of the circuit design according to rules created
5 specifically and automatically for a set of circuit elements in a netlist of the circuit
6 design including clock network flip-flops, the rules specifying positioning of each
7 circuit element of the set of circuit elements in the circuit design relative to other
8 circuit elements of the set of circuit elements in the circuit design; and
9 completing placement, routing, and optimization of the netlist of the
10 circuit design according to the rules.
- 1 2. The method of claim 1, further including:
2 after the coarse placement and before clock tree synthesis of the circuit design,
3 automatically creating the clock network flip-flops in the netlist of the circuit design.
- 1 3. The method of claim 1, further including:
2 after the coarse placement and before clock tree synthesis of the circuit design,
3 automatically creating the clock network flip-flops in the netlist of the circuit design
4 based on clock sinks in the netlist.
- 1 4. The method of claim 1, further including:
2 after the coarse placement and before clock tree synthesis of the circuit design,
3 automatically grouping the clock network flip-flops into a plurality of flip-flop groups.
- 1 5. The method of claim 1, further including:
2 after the coarse placement and before clock tree synthesis of the circuit design,
3 automatically grouping the clock network flip-flops into a plurality of flip-flop groups,
4 wherein the rules automatically created for the clock network flip-flops are based
5 on the plurality of flip-flop groups.

- 1 6. The method of claim 1, further including:
2 after the coarse placement and before clock tree synthesis of the circuit design,
3 performing clock tree clustering that automatically groups the clock network flip-flops
4 into a plurality of flip-flop groups.
- 1 7. The method of claim 1, further including:
2 after the coarse placement and before clock tree synthesis of the circuit design,
3 performing clock tree clustering that automatically groups the clock network flip-flops
4 into a plurality of flip-flop groups, without creating clock network buffer circuitry.
- 1 8. The method of claim 1, further including:
2 after the coarse placement and before clock tree synthesis of the circuit design,
3 performing clock tree clustering that automatically groups the clock network flip-flops
4 into a plurality of flip-flop groups,
5 wherein the rules automatically created for the clock network flip-flops are based
6 on the plurality of flip-flop groups from the clock tree clustering.
- 1 9. The method of claim 1, further including:
2 after the coarse placement and before clock tree synthesis of the circuit design,
3 performing clock tree clustering that automatically groups the clock network flip-flops
4 into a plurality of flip-flop groups; and
5 during placement of the circuit design, automatically creating clock network
6 buffer circuitry for the plurality of flip-flop groups.
- 1 10. The method of claim 1, wherein the clock network flip-flops are leaf nodes of a
2 clock tree of the circuit design.
- 1 11. The method of claim 1, further including:
2 during placement of the circuit design, automatically adding clock network buffer
3 circuitry matched to the grouped clock network flip-flops in the circuit design.

1 12. The method of claim 1, wherein the rules obey clock tree constraints specified for
2 the circuit design.

1 13. A computer readable medium with computer readable instructions executable by a
2 computer system, comprising:

3 instructions generating with the computer system a placed, routed, and optimized
4 circuit design, including:

5 instructions guiding coarse placement of the circuit design according to
6 rules created specifically and automatically for a set of circuit elements in a netlist
7 of the circuit design including clock network flip-flops, the rules specifying
8 positioning of each circuit element of the set of circuit elements in the circuit
9 design relative to other circuit elements of the set of circuit elements in the circuit
10 design,

11 instructions completing placement, routing, and optimization of the netlist
12 of the circuit design according to the rules.

1 14. The computer readable medium of claim 1, further including:

2 instructions, after the coarse placement and before clock tree synthesis of the
3 circuit design, automatically creating the clock network flip-flops in the netlist of the
4 circuit design.

1 15. The computer readable medium of claim 1, further including:

2 instructions, after the coarse placement and before clock tree synthesis of the
3 circuit design, automatically creating the clock network flip-flops in the netlist of the
4 circuit design based on clock sinks in the netlist.

1 16. The computer readable medium of claim 1, further including:

2 instructions, after the coarse placement and before clock tree synthesis of the
3 circuit design, automatically grouping the clock network flip-flops into a plurality of flip-
4 flop groups.

1 17. The computer readable medium of claim 1, further including:
2 instructions, after the coarse placement and before clock tree synthesis of the
3 circuit design, automatically grouping the clock network flip-flops into a plurality of flip-
4 flop groups,
5 wherein the rules automatically created for the clock network flip-flops are based
6 on the plurality of flip-flop groups.

1 18. The computer readable medium of claim 1, further including:
2 instructions, after the coarse placement and before clock tree synthesis of the
3 circuit design, performing clock tree clustering that automatically groups the clock
4 network flip-flops into a plurality of flip-flop groups.

1 19. The computer readable medium of claim 1, further including:
2 instructions, after the coarse placement and before clock tree synthesis of the
3 circuit design, performing clock tree clustering that automatically groups the clock
4 network flip-flops into a plurality of flip-flop groups, without creating clock network
5 buffer circuitry.

1 20. The computer readable medium of claim 1, further including:
2 instructions, after the coarse placement and before clock tree synthesis of the
3 circuit design, performing clock tree clustering that automatically groups the clock
4 network flip-flops into a plurality of flip-flop groups,
5 wherein the rules automatically created for the clock network flip-flops are based
6 on the plurality of flip-flop groups from the clock tree clustering.

1 21. The computer readable medium of claim 1, further including:
2 instructions, after the coarse placement and before clock tree synthesis of the
3 circuit design, performing clock tree clustering that automatically groups the clock
4 network flip-flops into a plurality of flip-flop groups; and
5 during placement of the circuit design, automatically creating clock network
6 buffer circuitry for the plurality of flip-flop groups.

1 22. The computer readable medium of claim 1, wherein the clock network flip-flops
2 are leaf nodes of a clock tree of the circuit design.

1 23. The computer readable medium of claim 1, further including:
2 instructions, during placement of the circuit design, automatically adding clock
3 network buffer circuitry matched to the grouped clock network flip-flops in the circuit
4 design.

1 24. The computer readable medium of claim 1, wherein the rules obey clock tree
2 constraints specified for the circuit design.

1 25. A data processing system adapted to process a computer implemented
2 representation of a circuit design, comprising:
3 a data processor and memory coupled to the data processor, the memory storing
4 instructions executable by the data processor, the instructions including:
5 instructions generating with the computer system a placed, routed, and
6 optimized circuit design, including:
7 instructions guiding coarse placement of the circuit design
8 according to rules created specifically and automatically for a set of circuit
9 elements in a netlist of the circuit design including clock network flip-
10 flops, the rules specifying positioning of each circuit element of the set of
11 circuit elements in the circuit design relative to other circuit elements of
12 the set of circuit elements in the circuit design,
13 instructions completing placement, routing, and optimization of the
14 netlist of the circuit design according to the rules.

1 26. A circuit, comprising:
2 a circuit following a placed, routed, and optimized circuit design, wherein the
3 placed, routed, and optimized circuit design is created by:
4 guiding coarse placement of the circuit design according to rules created
5 specifically and automatically for a set of circuit elements in a netlist of the circuit

6 design including clock network flip-flops, the rules specifying positioning of each
7 circuit element of the set of circuit elements in the circuit design relative to other
8 circuit elements of the set of circuit elements in the circuit design; and
9 completing placement, routing, and optimization of the netlist of the
10 circuit design according to the rules.

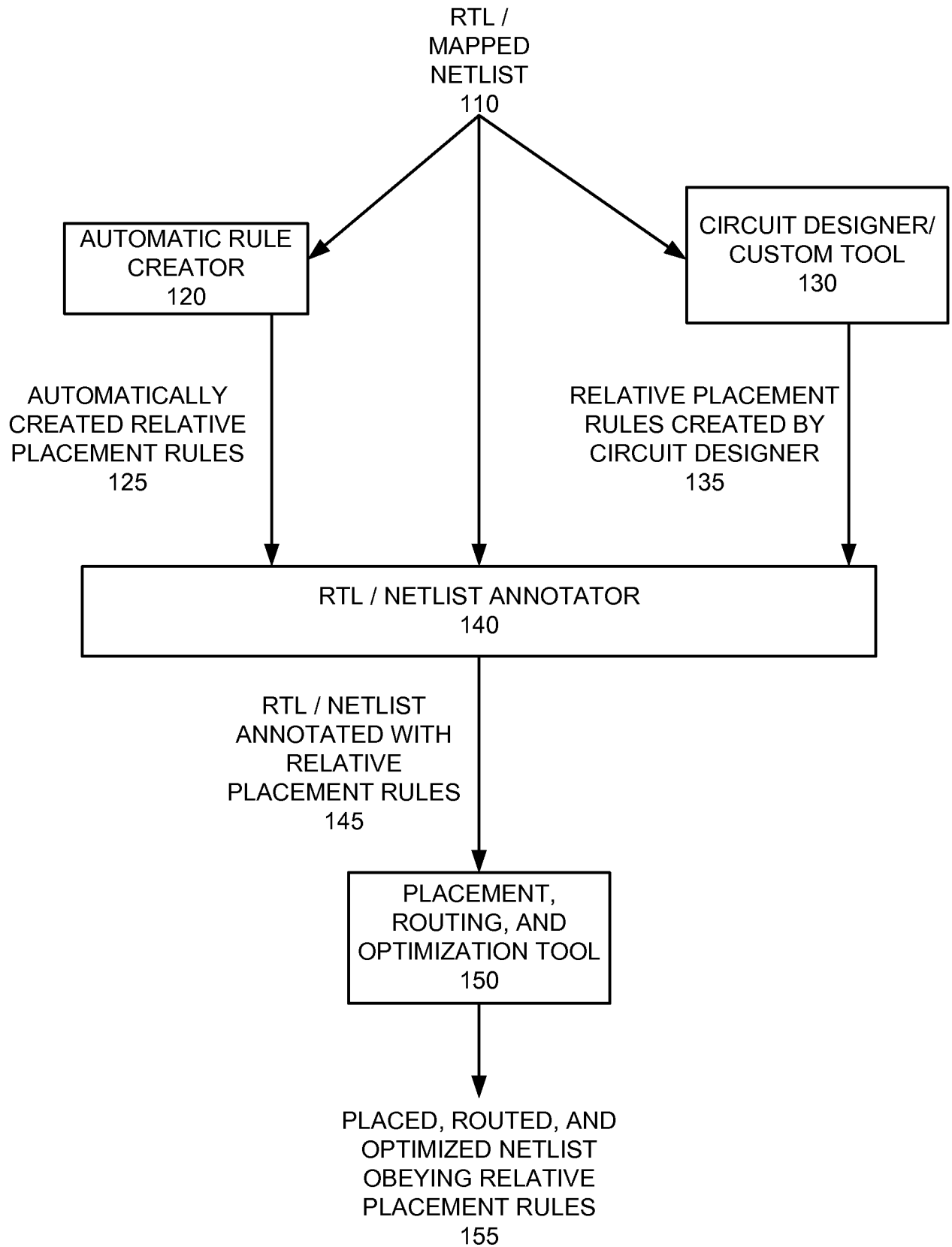

Fig. 1

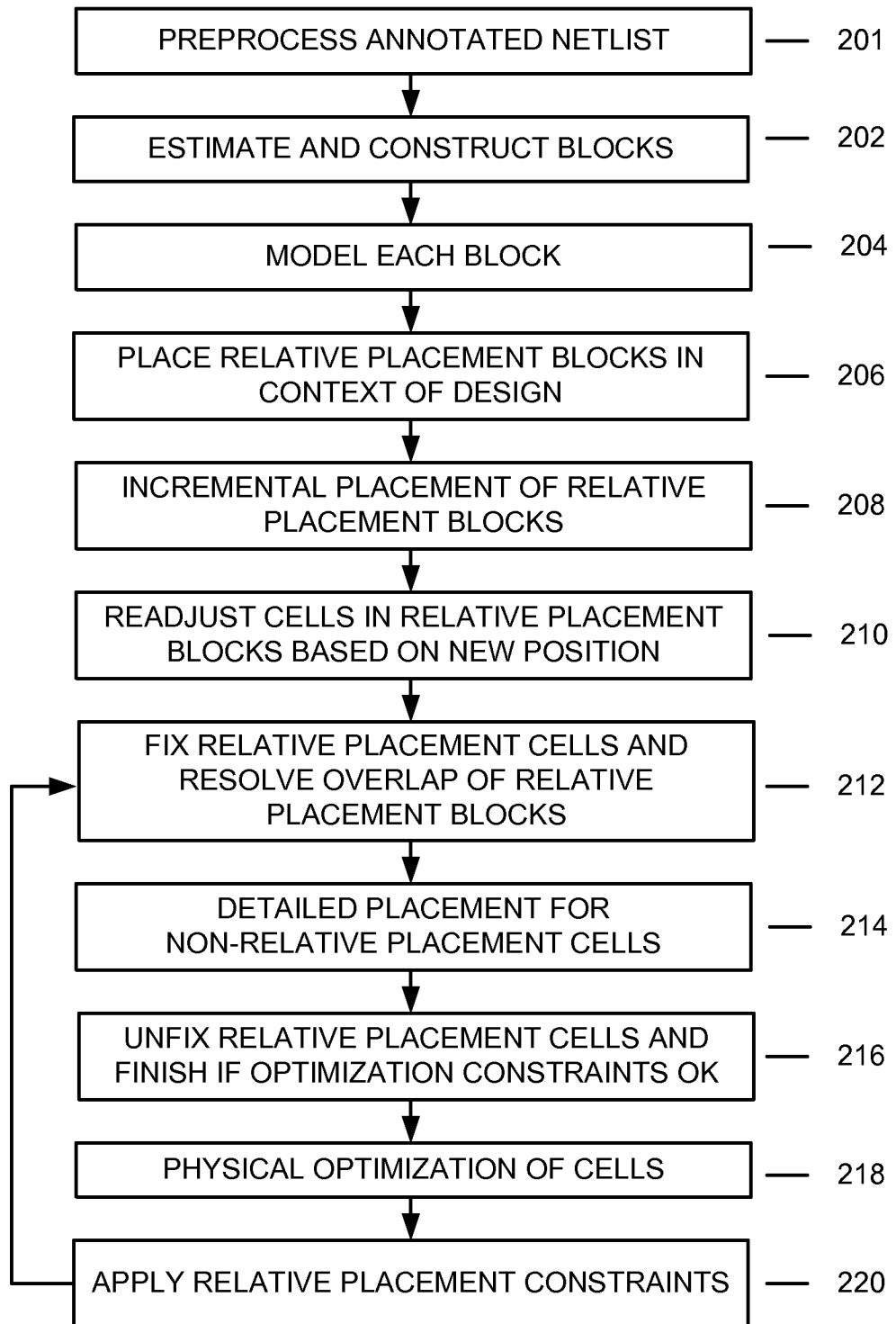

Fig. 2

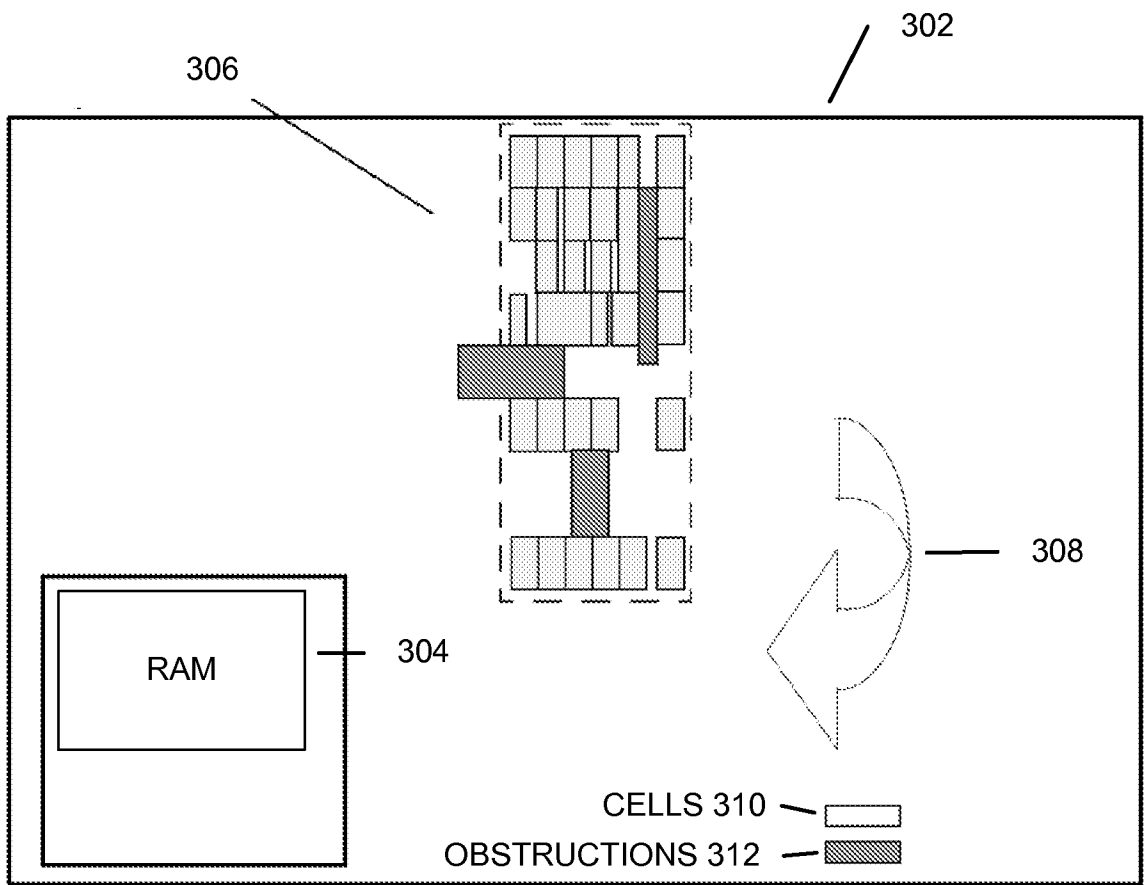

Fig. 3

/ 400

row-5	0 5	1 5	2 5	3 5	4 5	5 5
row-4	0 4	1 4	2 4	3 4	4 3	5 4
row-3		1 3	2 3	3 3		5 3
row-2	0 2	1 2		3 2	4 2	5 2
row-1	0 1	1 1	2 1	3 1		5 1
row-0	0 0	1 0	2 0	3 0	4 0	5 0
	col-0	col-1	col-2	col-3	col-4	col-5

Fig. 4

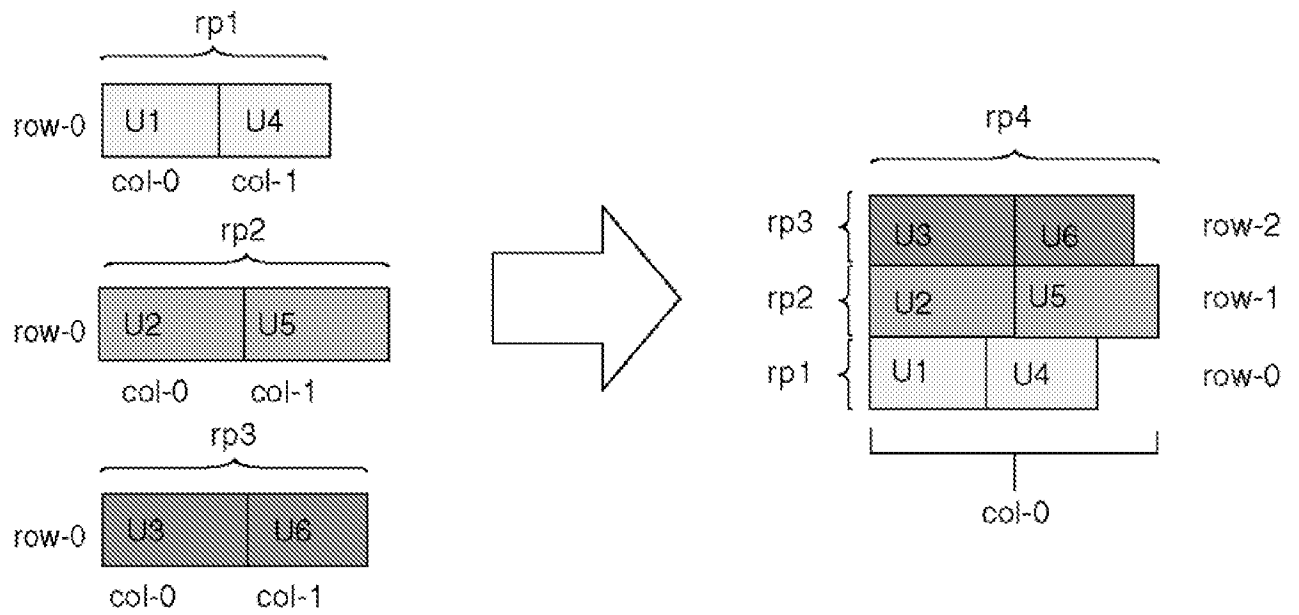

Fig. 5

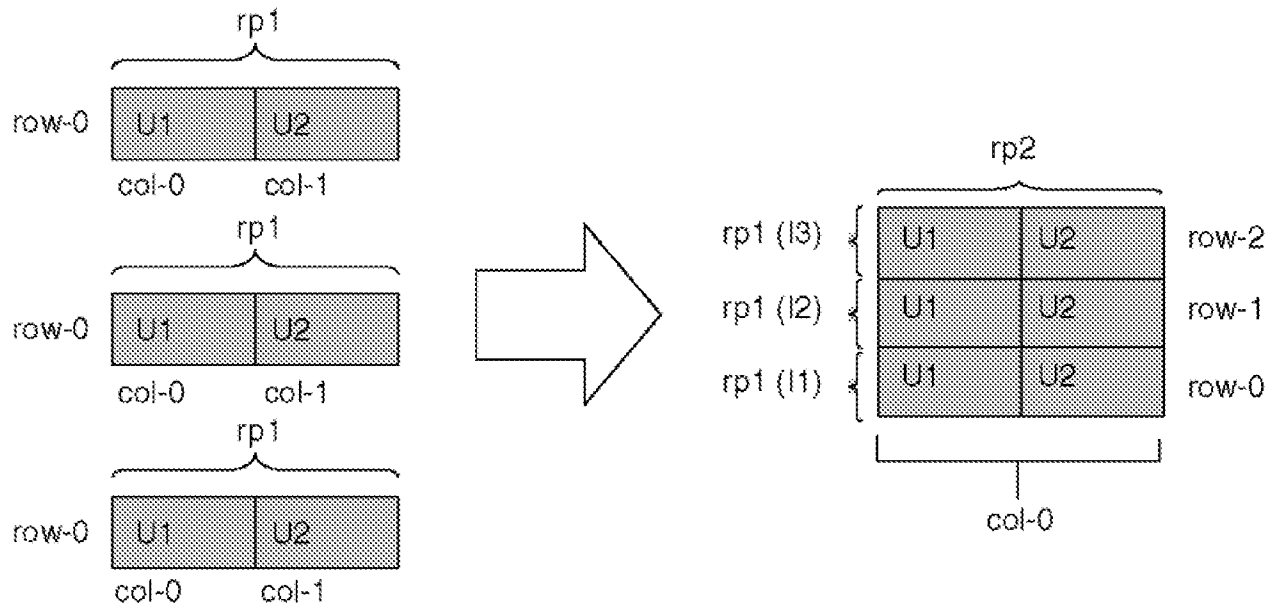

Fig. 6

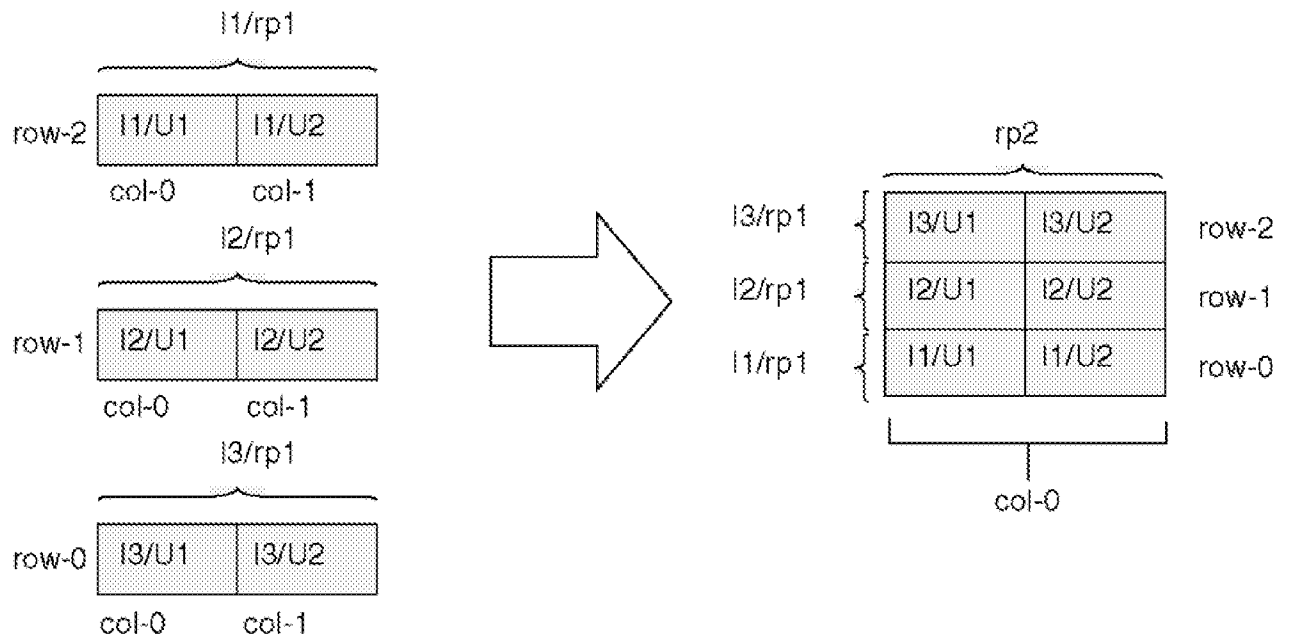

Fig. 7

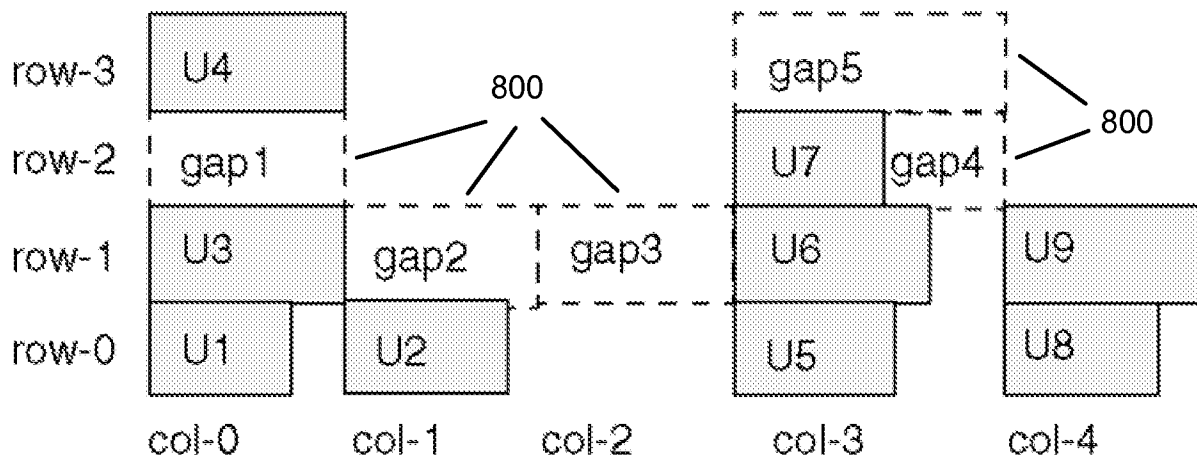

Fig. 8

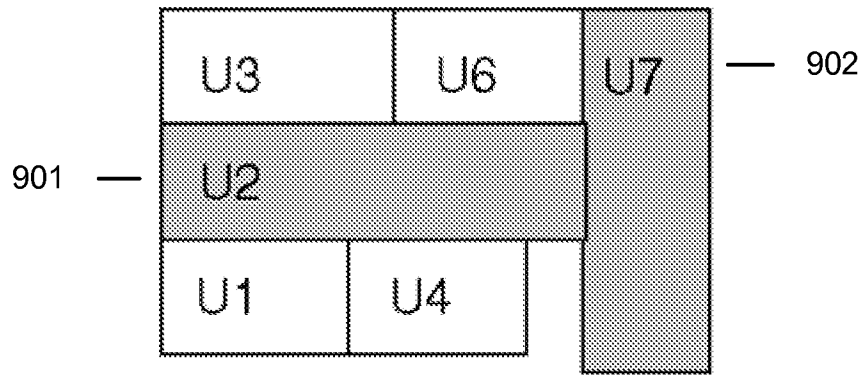

Fig. 9

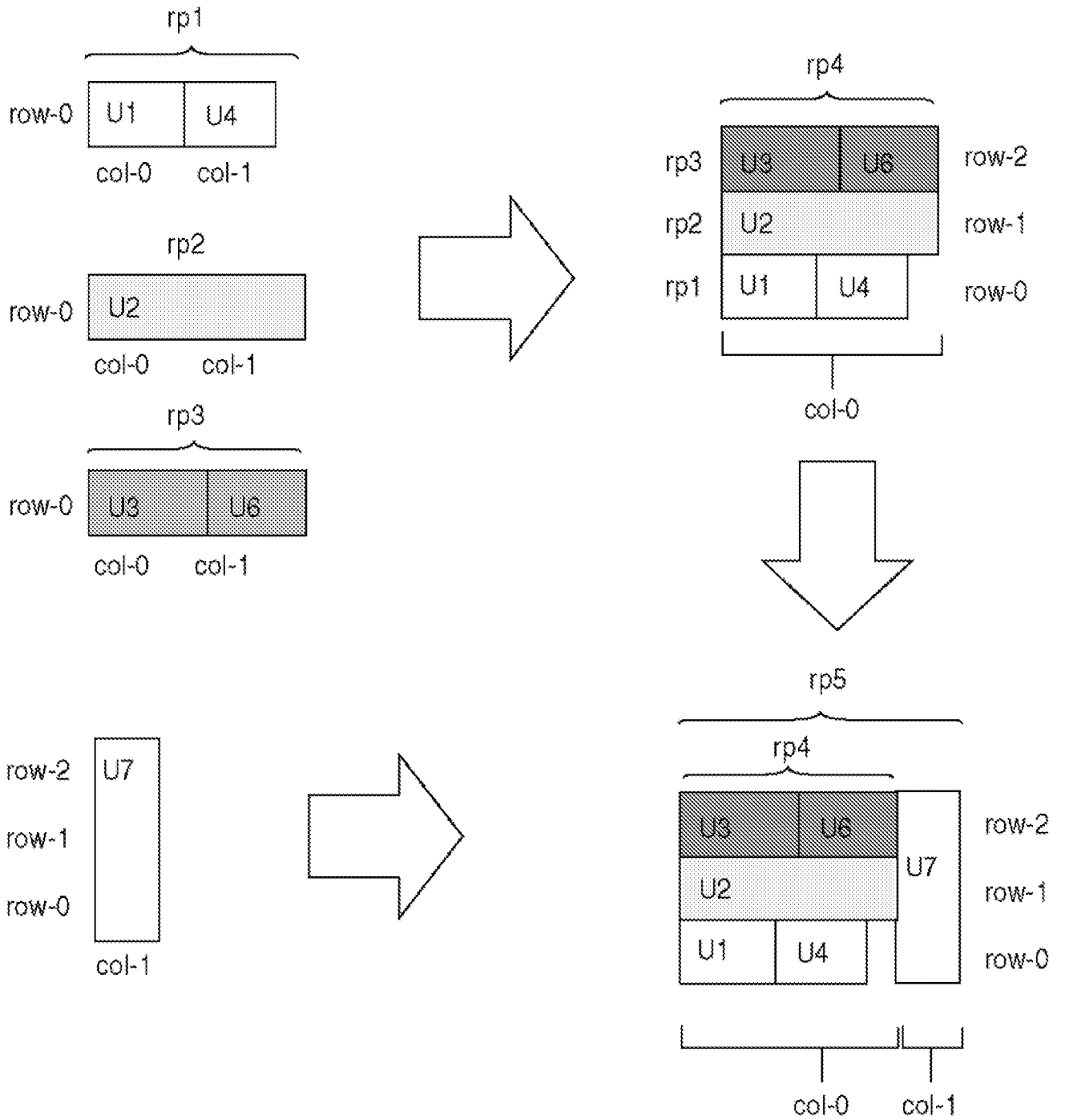

Fig. 10

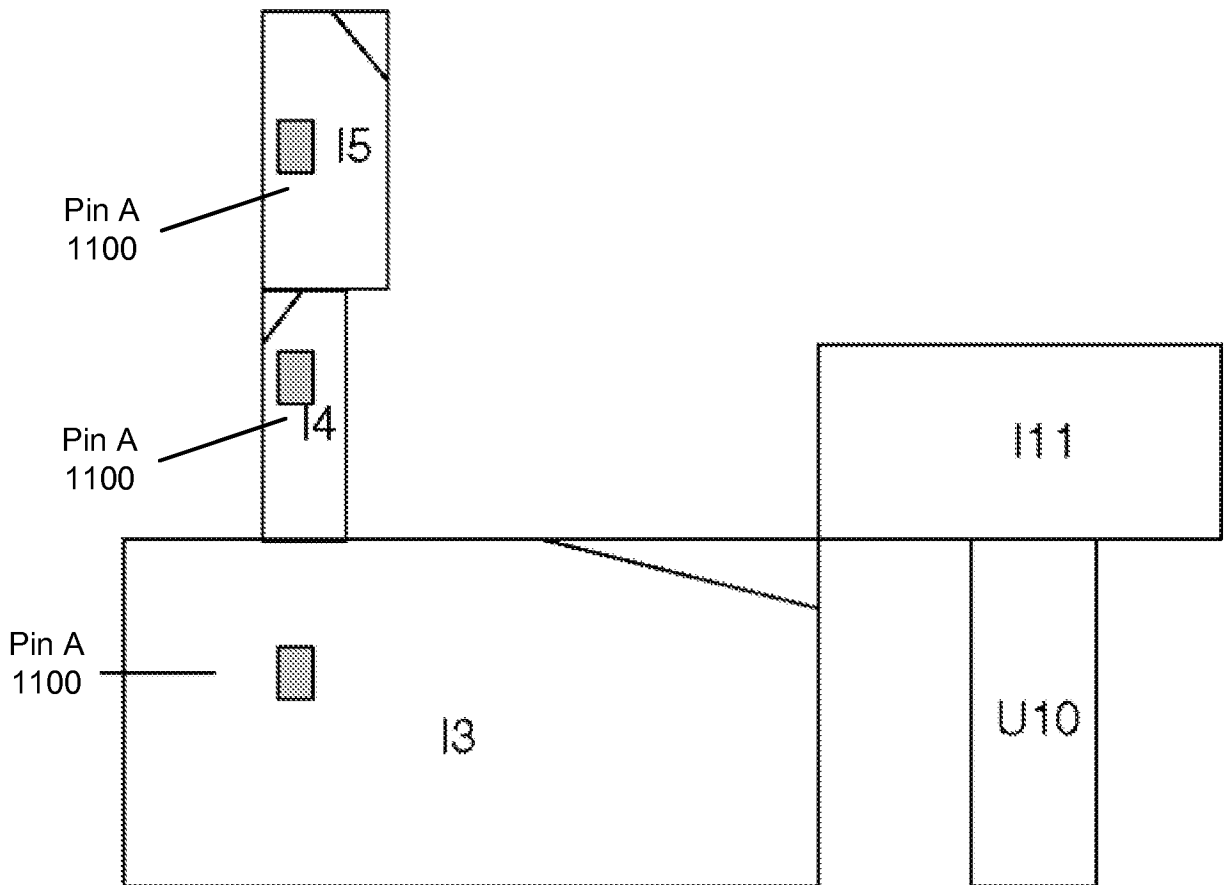

Fig. 11

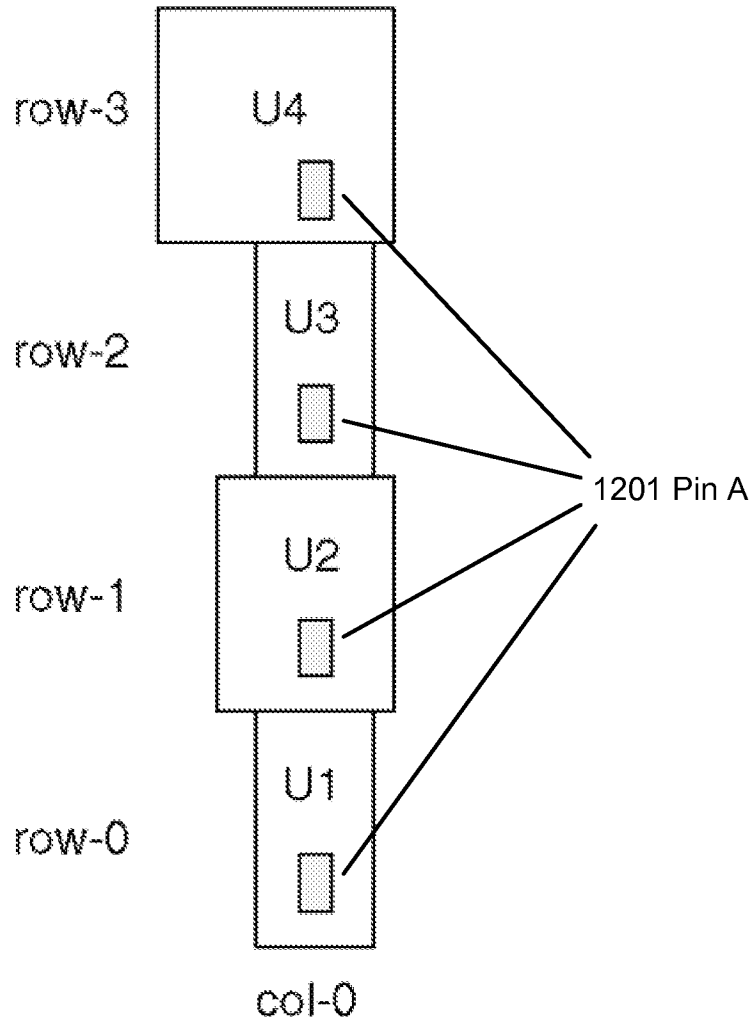

Fig. 12

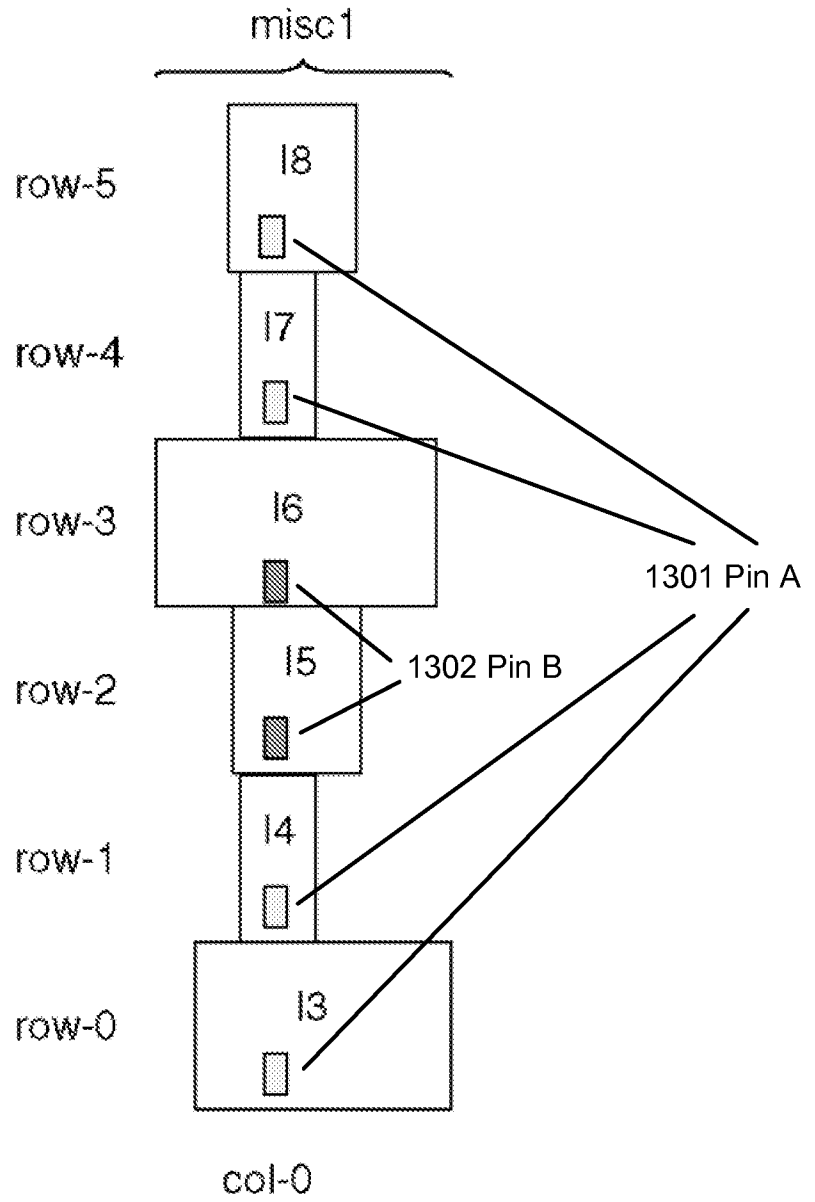

Fig. 13

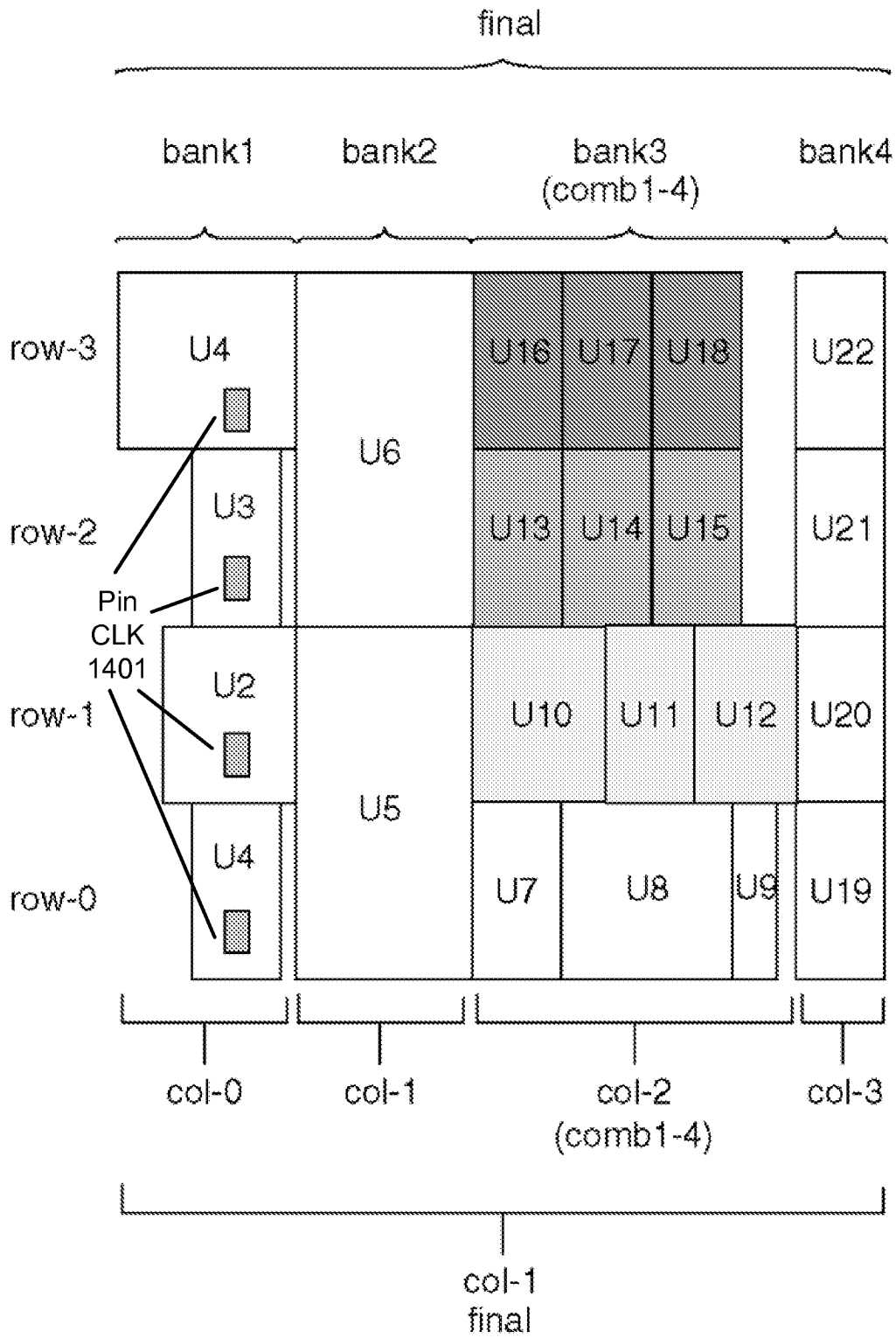

Fig. 14

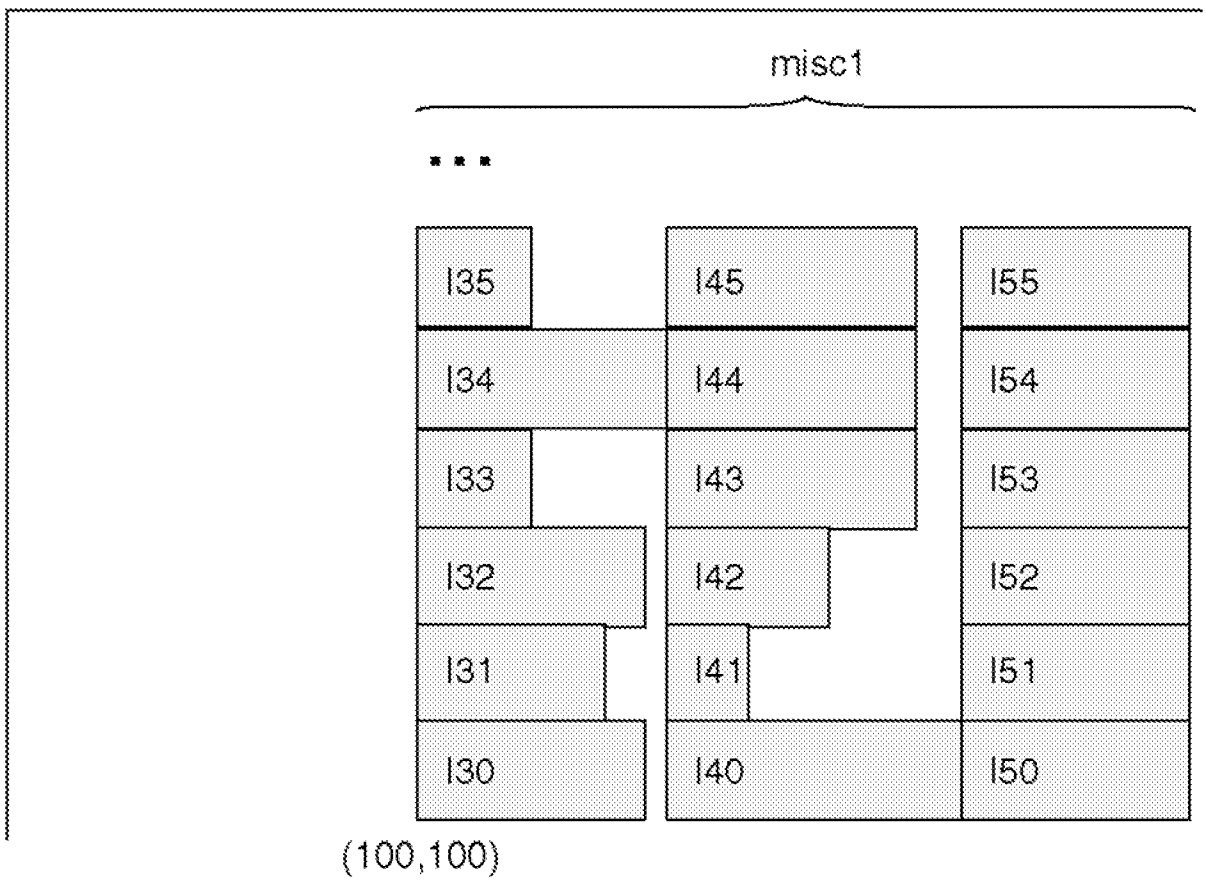

Fig. 15

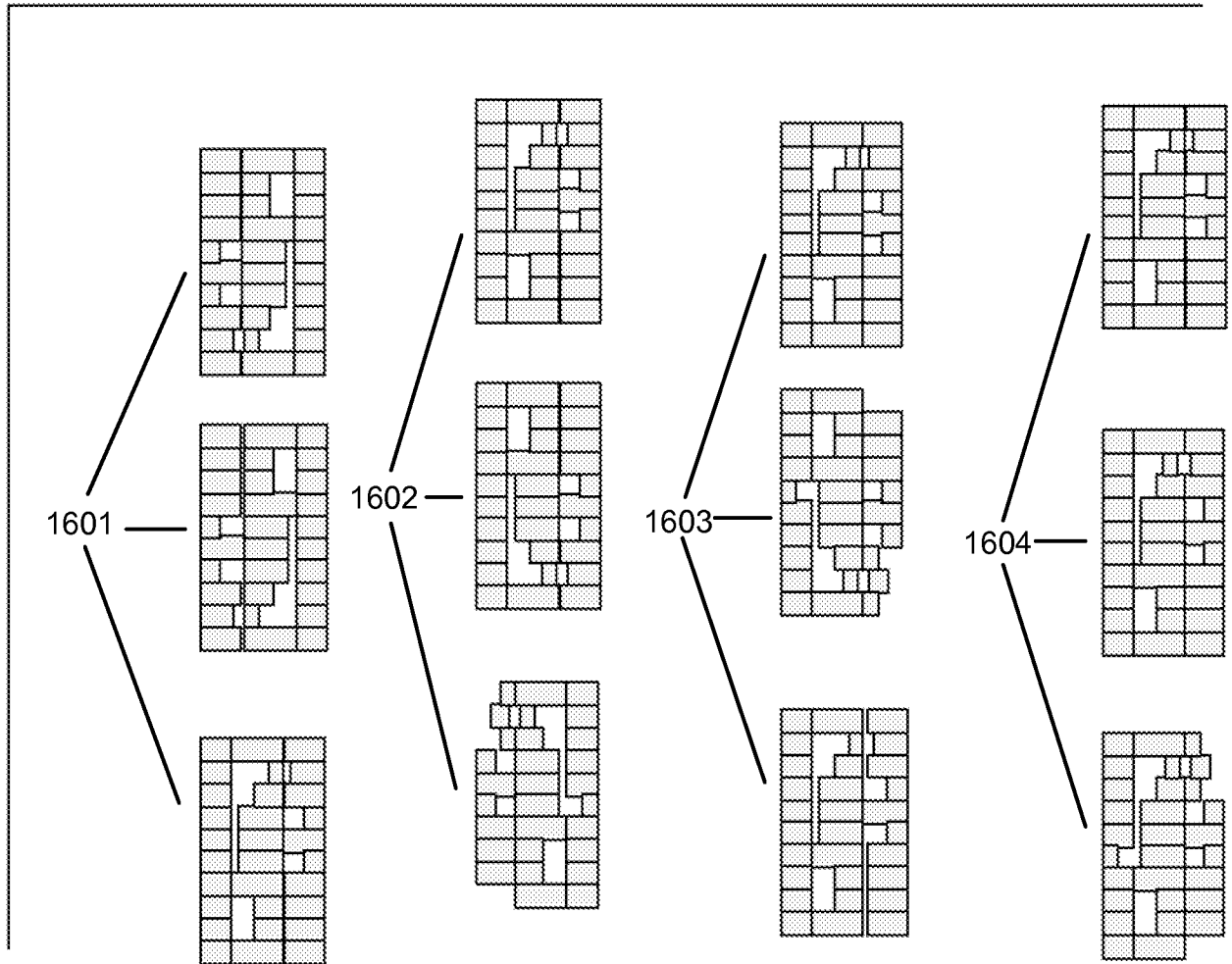

Fig. 16

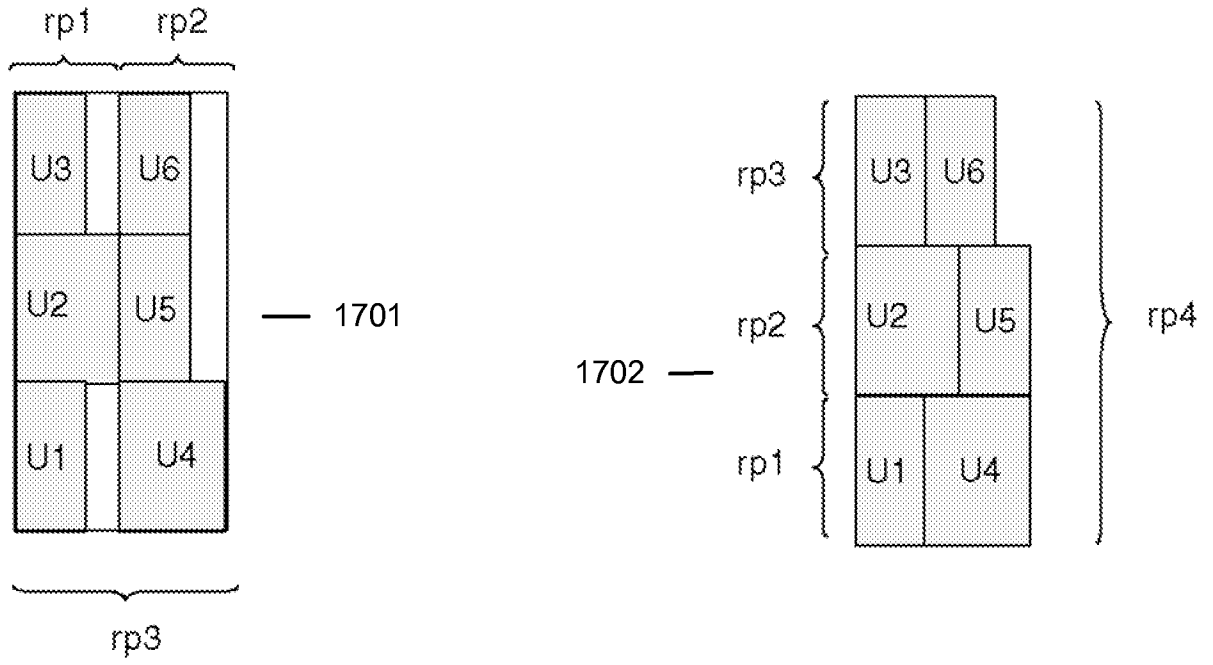

Fig. 17

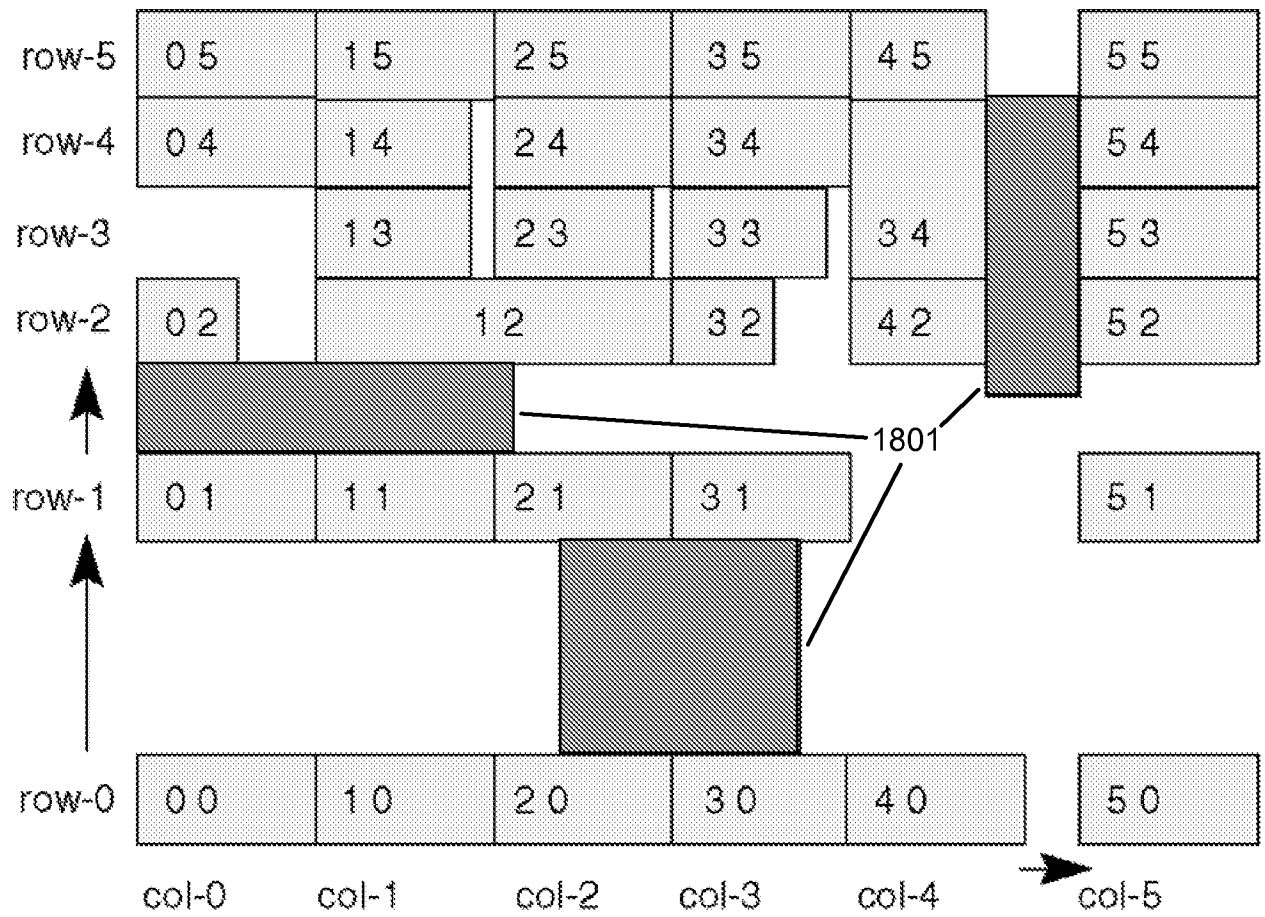

Fig. 18

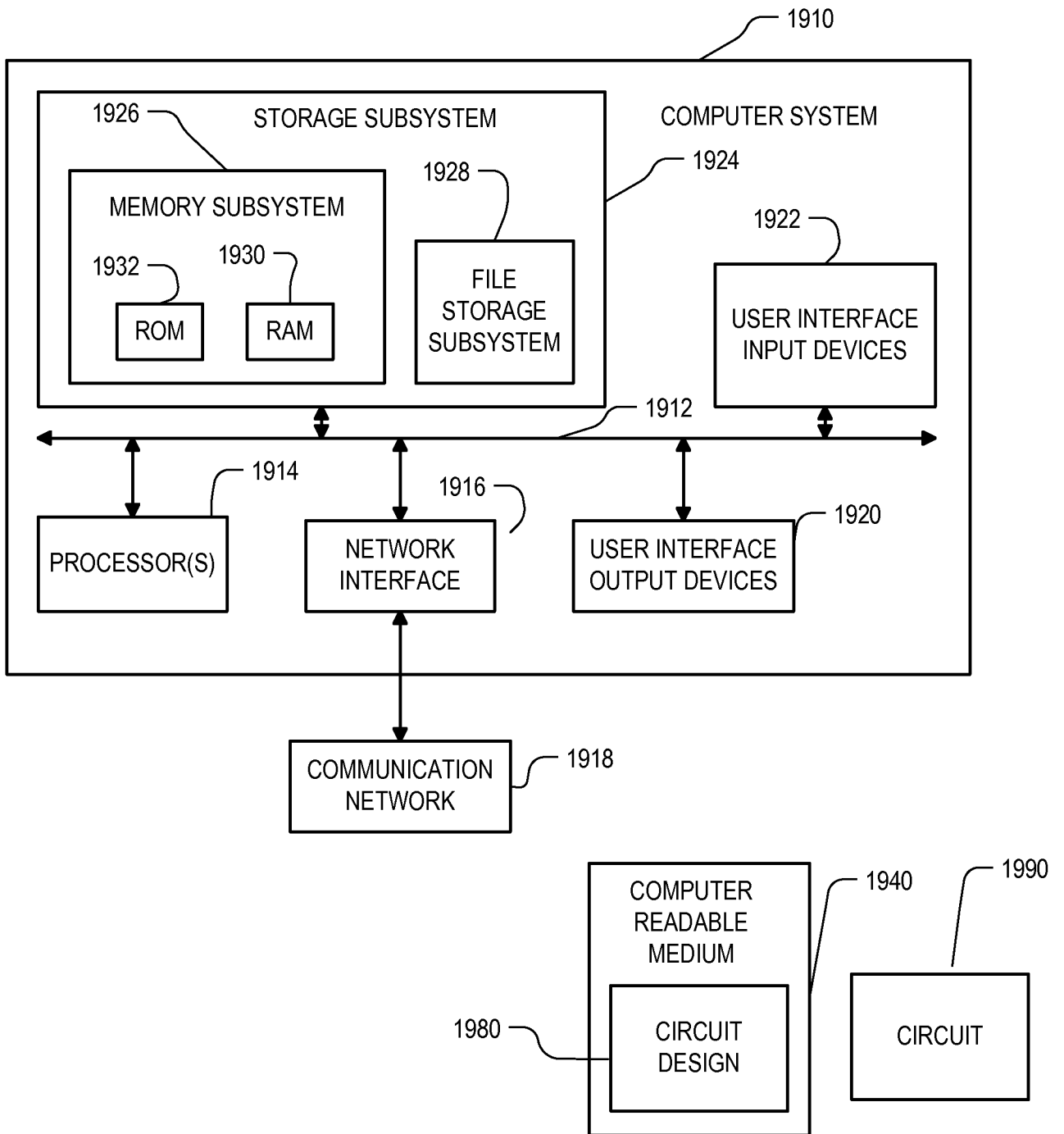

FIG. 19

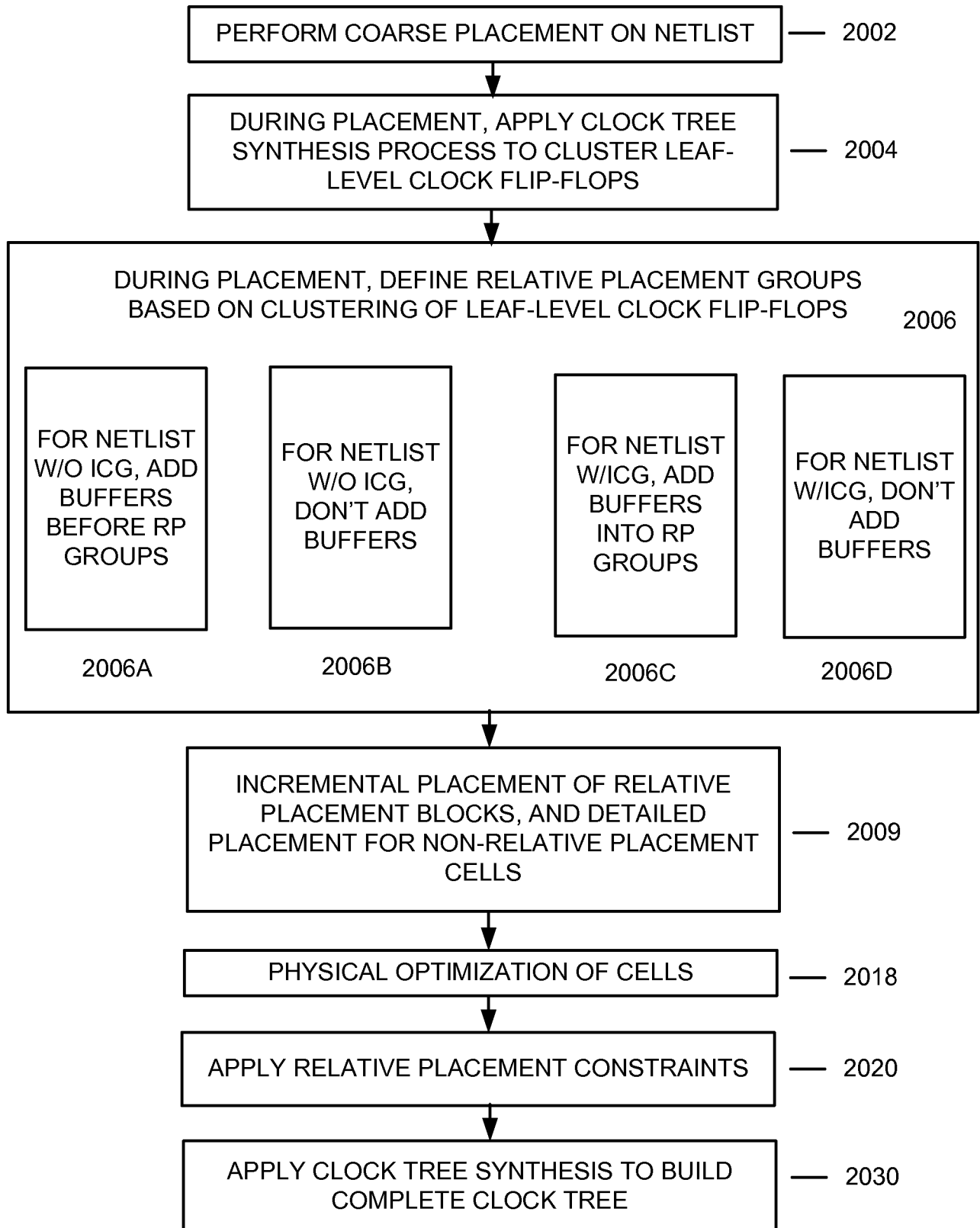

Fig. 20

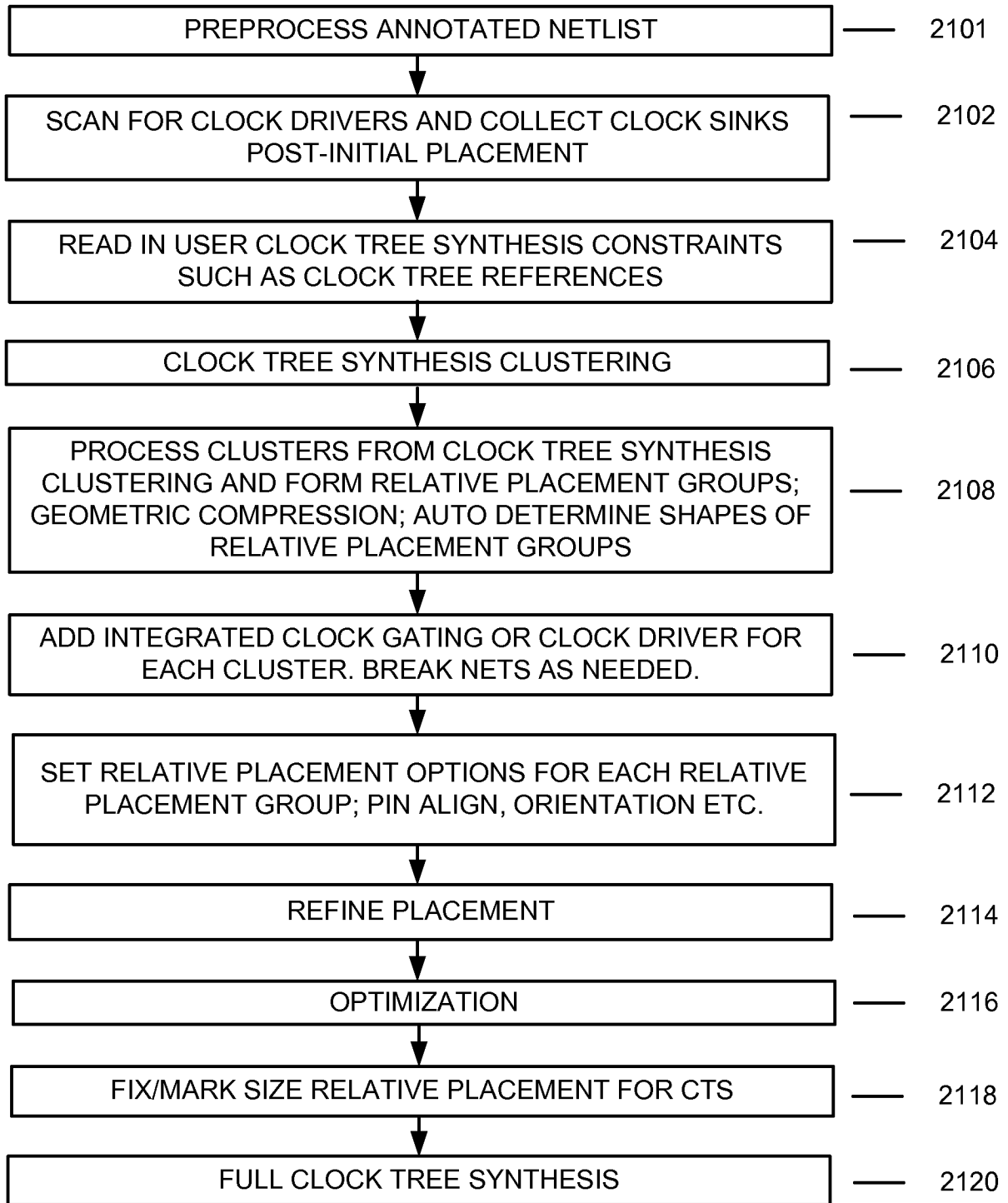

Fig. 21

A. CLASSIFICATION OF SUBJECT MATTER**G06F 17/50(2006.01)i**

According to International Patent Classification (IPC) or to both national classification and IPC

B. FIELDS SEARCHED

Minimum documentation searched (classification system followed by classification symbols)

IPC : G06F

Documentation searched other than minimum documentation to the extent that such documents are included in the fields searched

Korean utility models and applications for utility models

Japanese utility models and applications for utility models

Electronic data base consulted during the international search (name of data base and, where practicable, search terms used)

circuit design, optimized, netlist, clock network flip-flop

C. DOCUMENTS CONSIDERED TO BE RELEVANT

Category*	Citation of document, with indication, where appropriate, of the relevant passages	Relevant to claim No.
Y	US 2009-0199142 A1 (ANAND ARUNACHALAM et al.) 06 August 2009 See abstract; paragraphs [0012-0019], [0048-0143], [0238-0252]; claims 1-40; figures 1-2.	1, 10, 12-13, 22 , 24-26
Y	HONGXIA WANG et al. 'Electromagnetic Interference and Digital Circuits : An Initial Study of Clock Networks' , In: Electromagnetics, Volume 26, 2006, pp.73-86 See abstract; pages 75-85.	1, 10, 12-13, 22 , 24-26
A	US 2009-0083685 A1 (ALEXANDER GIDON et al.) 26 March 2009 See abstract; paragraphs [0035]-[0040],[0052]-[0090]; figures 7,9,11.	1-26
A	US 2004-0078767 A1 (TIMOTHY M. BURKS et al.) 22 April 2004 See abstract; paragraphs [0013],[0028]-[0126]; figures 1-13.	1-26

 Further documents are listed in the continuation of Box C. See patent family annex.

* Special categories of cited documents:

"A" document defining the general state of the art which is not considered to be of particular relevance

"E" earlier application or patent but published on or after the international filing date

"L" document which may throw doubts on priority claim(s) or which is cited to establish the publication date of citation or other special reason (as specified)

"O" document referring to an oral disclosure, use, exhibition or other means

"P" document published prior to the international filing date but later than the priority date claimed

"T" later document published after the international filing date or priority date and not in conflict with the application but cited to understand the principle or theory underlying the invention

"X" document of particular relevance; the claimed invention cannot be considered novel or cannot be considered to involve an inventive step when the document is taken alone

"Y" document of particular relevance; the claimed invention cannot be considered to involve an inventive step when the document is combined with one or more other such documents, such combination being obvious to a person skilled in the art

"&" document member of the same patent family

Date of the actual completion of the international search

20 DECEMBER 2012 (20.12.2012)

Date of mailing of the international search report

21 DECEMBER 2012 (21.12.2012)

Name and mailing address of the ISA/KR

Korean Intellectual Property Office
189 Cheongsu-ro, Seo-gu, Daejeon Metropolitan
City, 302-701, Republic of Korea

Facsimile No. 82-42-472-7140

Authorized officer

lee Jung Eun

Telephone No. 82-42-481-5391



INTERNATIONAL SEARCH REPORT

Information on patent family members

International application No.

PCT/US2012/051204

Patent document cited in search report	Publication date	Patent family member(s)	Publication date
US 2009-0199142 A1	06.08.2009	US 7937682 B2	03.05.2011
US 2009-0083685 A1	26.03.2009	US 2005-062496 A1 US 7584441 B2 US 8060844 B2 WO 2005-029262 A2	24.03.2005 01.09.2009 15.11.2011 31.03.2005
US 2004-0078767 A1	22.04.2004	US 7103863 B2	05.09.2006