



(12) **EUROPEAN PATENT APPLICATION**

(43) Date of publication:
03.10.2007 Bulletin 2007/40

(51) Int Cl.:
E05B 63/20 (2006.01)

(21) Application number: **07103817.8**

(22) Date of filing: **09.03.2007**

(84) Designated Contracting States:
AT BE BG CH CY CZ DE DK EE ES FI FR GB GR HU IE IS IT LI LT LU LV MC MT NL PL PT RO SE SI SK TR
 Designated Extension States:
AL BA HR MK YU

(71) Applicant: **BJÖRKBODA LAS OY AB**
25860 Björkboda (FI)

(72) Inventor: **Nabb, Peter**
FI-25840, Nivelax (FI)

(30) Priority: **28.03.2006 FI 20065200**

(74) Representative: **Gustafsson, Aulis Valdemar et al**
AWEK Industrial Patents Ltd Oy
P.O. Box 230
00101 Helsinki (FI)

(54) **Auxiliary bolt arrangement in a door lock**

(57) An auxiliary bolt arrangement in a door lock comprising a lock casing (1), which is provided with a latch bolt (3) spring-loaded to a protruding position and with an auxiliary bolt (5) spring-loaded to a protruding position for controlling the operation of the latch bolt and in which the latch bolt (3) has at least two different protruding positions with different extent of protrusion, whereby the auxiliary bolt arrangement is adapted to control the latch bolt (3) so that it allows the movement of the latch bolt (3) to its outermost protruding position only in case both the latch bolt (3) and the auxiliary bolt (5) are first moved into their retracted positions in the lock casing (1). The auxiliary bolt arrangement includes a restraining member (9), which the auxiliary bolt (5) in its protruding position is arranged to press against the force of a spring (10) to a position, in which the restraining member (9) prevents the movement of the latch bolt (3) to its outermost protruding position. In addition, the latch bolt (3) is adapted to retain the restraining member (9) in said position, if solely the auxiliary bolt (5) is being pressed inside the lock casing (1).

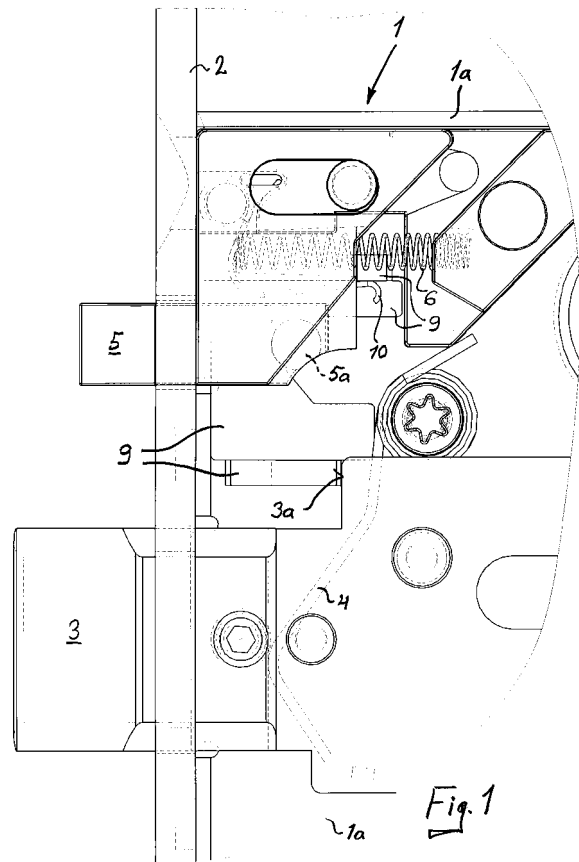

Description

[0001] The invention relates to an auxiliary bolt arrangement in a door lock in accordance with the preamble of claim 1.

[0002] In the here referred door locks provided with a latch bolt two different protruding positions with different extent of protrusion may be arranged for the latch bolt. In the first position, the door can be pressed closed, whereby the bevelled surface of the latch bolt hits the striker plate in the doorframe, which plate urges the latch bolt against its spring inside the lock. The outermost position of the latch bolt is intended for the actual locking of the door and in this position of the latch bolt the door cannot be pressed closed as described above. In this case the lock also includes an auxiliary bolt, the purpose of which is to prevent the movement of the latch bolt to its outermost position, while the door is open, and on the other hand, to allow the latch bolt to move to its outermost position urged by its spring after the door has been pressed closed.

[0003] When the door is open, both the latch bolt and the auxiliary bolt in this lock type are in their protruding positions. If the auxiliary bolt is then inserted into the lock casing by accident or with malicious intention, the latch bolt is simultaneously released to its outermost protruding position thus preventing the pressing of the door closed. Usually, the latch bolt becomes deadlocked at the same time and the deadlocking as well needs to be first separately disengaged, for instance by key actuation, before the latch bolt can be moved to its inner position, which enables the closing of the door.

[0004] One solution for eliminating this malfunction is disclosed in the publication FI 115066, which corresponds to the publication WO 02/66774 A1. The solution is based on the principle that it allows the movement of the latch bolt to its outermost protruding position only in case both the latch bolt and the auxiliary bolt are first moved into their retracted positions inside the lock casing. This occurs also in the normal usage of the lock, when the door is being closed, but here a mechanism is provided for applying this principle in order to eliminate said malfunction. This solution has, however, a complicated structure, since it includes a separate control member, which is dependent on the movement of the auxiliary bolt, for controlling a turnable retaining member acting on the latch bolt. In addition, the control member and the retaining member are further connected to a movable force transmission means, which is used for retracting the latch bolt inside the lock casing.

[0005] A purpose of the invention is to provide a novel and reliable solution with a simplest possible structure for efficient elimination of the above described malfunction. An additional purpose is to make the solution as independent of various other force transmission means acting on the latch bolt as possible so that it may be adapted in as many different kind of lock casing applications as possible.

[0006] The objects of the invention are achieved primarily as disclosed in the appended claim 1, and more closely as explained in the other claims. According to the invention the auxiliary bolt arrangement includes a restraining member, which the auxiliary bolt in its protruding position is arranged to press against the force of a spring to a position, in which the restraining member prevents the movement of the latch bolt to its outermost protruding position. In addition, the latch bolt is arranged to retain the restraining member in said position, if solely the auxiliary bolt is being pressed inside the lock casing.

[0007] In a practical solution the auxiliary bolt and the restraining member have counter surfaces, which are mutually arranged so that the movement of the auxiliary bolt away from the lock casing actuates the movement of the restraining member towards the latch bolt. When the force of the spring of the auxiliary bolt is chosen so that it overcomes the spring force of the restraining member, it can be assured that the restraining member moves to right direction guided by the auxiliary bolt.

[0008] In one preferable embodiment the auxiliary bolt is provided with a guiding pin, which acts on the restraining member's guide surface, which is bevelled with respect to the direction of the movement.

[0009] Preferably, the latch bolt is provided with a shoulder or the like arranged in cooperation with the restraining member. When the restraining member is in its preventing position, the spring of the latch bolt may preferably be arranged so as to urge the restraining member against the lock casing in order to retain the restraining member in its place.

[0010] A preferable practical embodiment is provided by arranging the restraining member to move mainly perpendicularly with respect to the movement of the latch bolt and the auxiliary bolt.

[0011] In the following, the invention is explained by way of example with reference to the appended drawings, in which

- 40 - Figure 1 depicts an enlarged side view of one embodiment of the invention, in which the lock casing is only partially shown and only partially opened in a situation corresponding to the open position of the door;
- 45 - Figure 2 depicts the solution according to Figure 1 seen from the other side of the lock casing so that the restraining member according to the invention is more clearly visible;
- 50 - Figure 3 depicts the lock casing of Figure 2 in a situation, in which the door is open and the latch bolt has been pressed inside;
- 55 - Figure 4 depicts the lock casing of Figure 2 in a situation, in which the door is being pressed closed and the latches are about to penetrate into the lock casing; and

- Figure 5 depicts the lock casing of Figure 2 in a situation, in which the door has been pressed closed and the latch bolt has moved to its outermost protruding position.

[0012] In the drawings the reference number 1 refers to a lock casing in a door lock provided with a housing 1 a and a front plate 2. The lock casing also includes a latch bolt 3, which a spring 4 tends to urge out from the lock casing, and an auxiliary bolt 5, which a spring 6 tends to urge out from the lock casing, and a restraining member 9 arranged in conjunction with the latch bolt 5, which a spring 10 tends to move in the direction away from the latch bolt 3, i.e. upwards in the drawings.

[0013] The lock casing is also provided with at least one operating axis, the force transmission means mounted on which axis can retract, in a manner known as such, the latch bolt 3 against the force of its spring 4 into the lock casing in the purpose of opening the door. In addition, the latch bolt 3 has two protruding positions, in the outermost of which it may be deadlocked in a way known as such. Naturally, in that case the retraction of the latch bolt requires also disengagement of deadlocking. The figures depict, by way of example, only operating axes 7 and 8, on which the means for providing key actuation, turning knob actuation and/or handle actuation may be mounted, as required. Since these factors are irrelevant to the application of the present invention, they are not described in more detail in this context. Likewise, the figures depict neither the door nor the door frame, into the striker plate opening of which the latch bolt 3 moves and against which the auxiliary bolt 5 is pressed, when the door is closed, since these are completely known and obvious facts within the field of locking.

[0014] So, in the situation shown in Figures 1 and 2 the door is open, whereby the latch bolt is in its inner protruding position and the auxiliary bolt 5 is protruded. The restraining member 9 in conjunction with the auxiliary bolt 5 is in a position, in which it lies against the shoulder 3a of the latch bolt 3 and prevents the moving of the latch bolt 3, urged by the spring 4, to its outermost protruding position. The auxiliary bolt 5 is provided with a guiding pin 5a, which is in cooperation with the bevelled guide surface 9a of the restraining member 9, whereby it in the situation according to the figures prevents the movement of the restraining member 9, urged by a spring 10, upwards in the figures. Consequently, the door can be pressed closed in a normal way, whereby the latch bolt 3 and the auxiliary bolt 5, when hitting the striking plate in the doorframe, penetrate into the lock casing, as shown in the Figure 4.

[0015] Figure 3 illustrates a situation, in which the auxiliary bolt 5 is being pressed inside, while the door is open. As shown in the figure, the pin 5a of the auxiliary bolt 5 no longer prevents the movement of the restraining member 9. In spite of this, the restraining member 9 stays in a position, in which it prevents the latch bolt 3 from moving to its outermost protruding position. This is due to the

fact that the restraining member 9 is, urged by the spring 4 of the latch bolt, between the shoulder 3a of the latch bolt and the inner surface of the lock casing 1. The restraining member 9 holds this position owing to the force of the spring 4 of the latch bolt and friction forces, and the weaker spring 10 acting on the restraining member 9 is not capable of moving the restraining member 9. In this way, the typical malfunction occurring in the former solutions is efficiently eliminated in a simple manner and by minimising the number of required parts.

[0016] In the situation according to Figure 4 the bolts 3 and 5 are urged inside the lock casing, as shown by arrows. In this case the restraining member 9 is released from the action of the shoulder 3a of the latch bolt and in addition, as the auxiliary bolt 5 has moved, its pin 5a no longer forms an obstacle, whereby the restraining member 9 is allowed to move, urged by the spring 10, upwards to the position of Figure 4, in which it is beyond reach of the shoulder 3a of the latch bolt 3.

[0017] Figure 5 depicts a situation, in which the door is closed as a result of the situation of Figure 4. Since the auxiliary bolt 5 lies against the striker plate and is not allowed to reach the totally protruded position, its pin 5a does not act on the guide surface 9a of the restraining member 9. Thus, the restraining member 9 holds the position according to Figures 4 and 5, whereby it does not prevent the movement of the latch bolt 3, urged by the spring 4, to its outermost protruding position according to Figure 5. When in this situation the aim is to reopen the door, the latch bolt 3 needs to be retracted inside the lock casing by means of the actuators mounted on one of the operating axes. After the door has passed the doorframe, the latch bolt 3 tends to protrude again from the lock casing urged by the spring 4. Simultaneously, also the auxiliary bolt 5 is urged by the spring 6 to its protruding position shown in Figures 1 and 2. Since the force of the spring 6 of the auxiliary bolt 5 has been chosen so that it overcomes the force of the spring 10 that tends to move the restraining member 9 upwards in the figures, the pin 5a of the auxiliary bolt 5 presses simultaneously, via the guiding surface 9a, the restraining member 9 to the position of Figures 1 and 2, in which it is placed in front of the shoulder 3a of the latch bolt 3 and allows the movement of the latch bolt 3 only to its inner protruding position.

[0018] The members in cooperation with one another in the solution according to the invention may be shaped in different ways in order to fulfil the desired purpose. As already stated in the above, the practical application of the invention is suitable for various kinds of lock casings independently of how the latch bolt in each case is retracted into the lock casing or what kind of deadlocking means are possibly in use. Also, the application of the invention does not depend on whether there are possibly other additional bolts in the lock casing, such as a forced deadbolt, or whether e.g. electrical control is used for controlling the operation of the various bolts.

[0019] The invention is not limited to the shown embodiment, but several variations are conceivable within

the scope of the appended claims.

Claims

1. An auxiliary bolt arrangement in a door lock comprising a lock casing (1), which is provided with a latch bolt (3) spring-loaded to a protruding position and with an auxiliary bolt (5) spring-loaded to a protruding position for controlling the operation of the latch bolt and in which the latch bolt (3) has at least two different protruding positions with different extent of protrusion, whereby the auxiliary bolt arrangement is adapted to control the latch bolt (3) so that it allows the movement of the latch bolt (3) to its outermost protruding position only in case both the latch bolt (3) and the auxiliary bolt (5) are first moved into their retracted positions in the lock casing (1), **characterised in that** it includes a restraining member (9), which the auxiliary bolt (5) in its protruding position is arranged to press against the force of a spring (10) to a position, in which the restraining member (9) prevents the movement of the latch bolt (3) to its outermost protruding position, and that the latch bolt (3) is adapted to retain the restraining member (9) in said position, if solely the auxiliary bolt (5) is being pressed inside the lock casing (1).
2. An auxiliary bolt arrangement according to claim 1, **characterised in that** the auxiliary bolt (5) and the restraining member (9) have counter surfaces, which are mutually arranged so that the movement of the auxiliary bolt (5) away from the lock casing (1) actuates the movement of the restraining member (9) towards the latch bolt (3).
3. An auxiliary bolt arrangement according to claim 2, **characterised in that** the spring (6) of the auxiliary bolt (5) is stronger than the spring (10) of the restraining member (9).
4. An auxiliary bolt arrangement according to claim 2 or 3, **characterised in that** the auxiliary bolt (5) is provided with a guiding pin (5a) acting on the restraining member's (9) guide surface (9a), which is bevelled with respect to the direction of the movement.
5. An auxiliary bolt arrangement according to anyone of the preceding claims, **characterised in that** the auxiliary bolt (3) is provided with a shoulder (3a) or the like, which is arranged in cooperation with the restraining member (9), and that the spring (4) of the latch bolt (3) is arranged to press the restraining member (9) against the lock casing (1), while the restraining member (9) is in its preventing position, in order to retain the restraining member (9) in its place.
6. An auxiliary bolt arrangement according to anyone of the preceding claims, **characterised in that** the restraining member (9) is arranged to move mainly perpendicularly with respect to the movement of the latch bolt (3) and the auxiliary bolt (5).

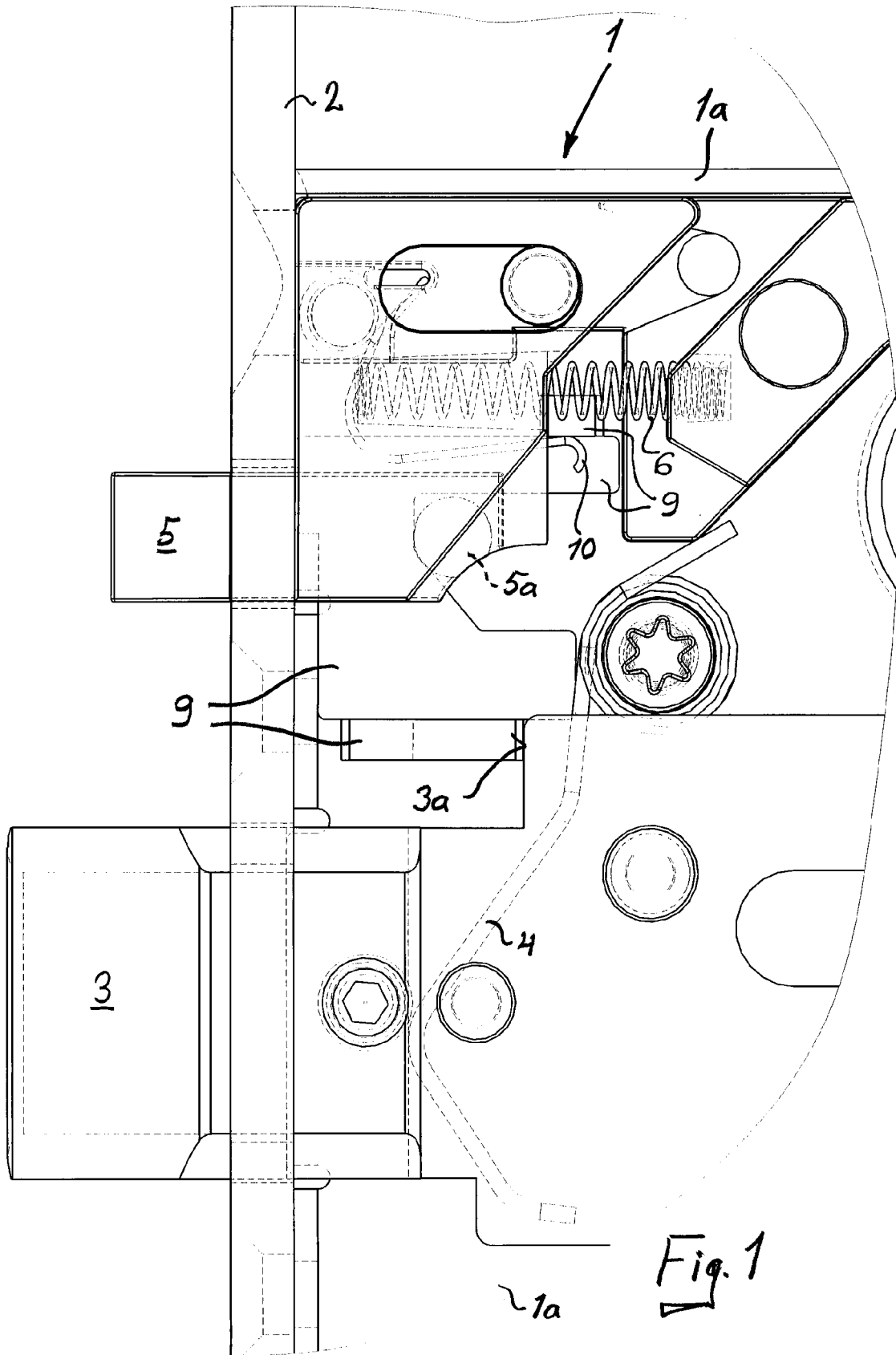

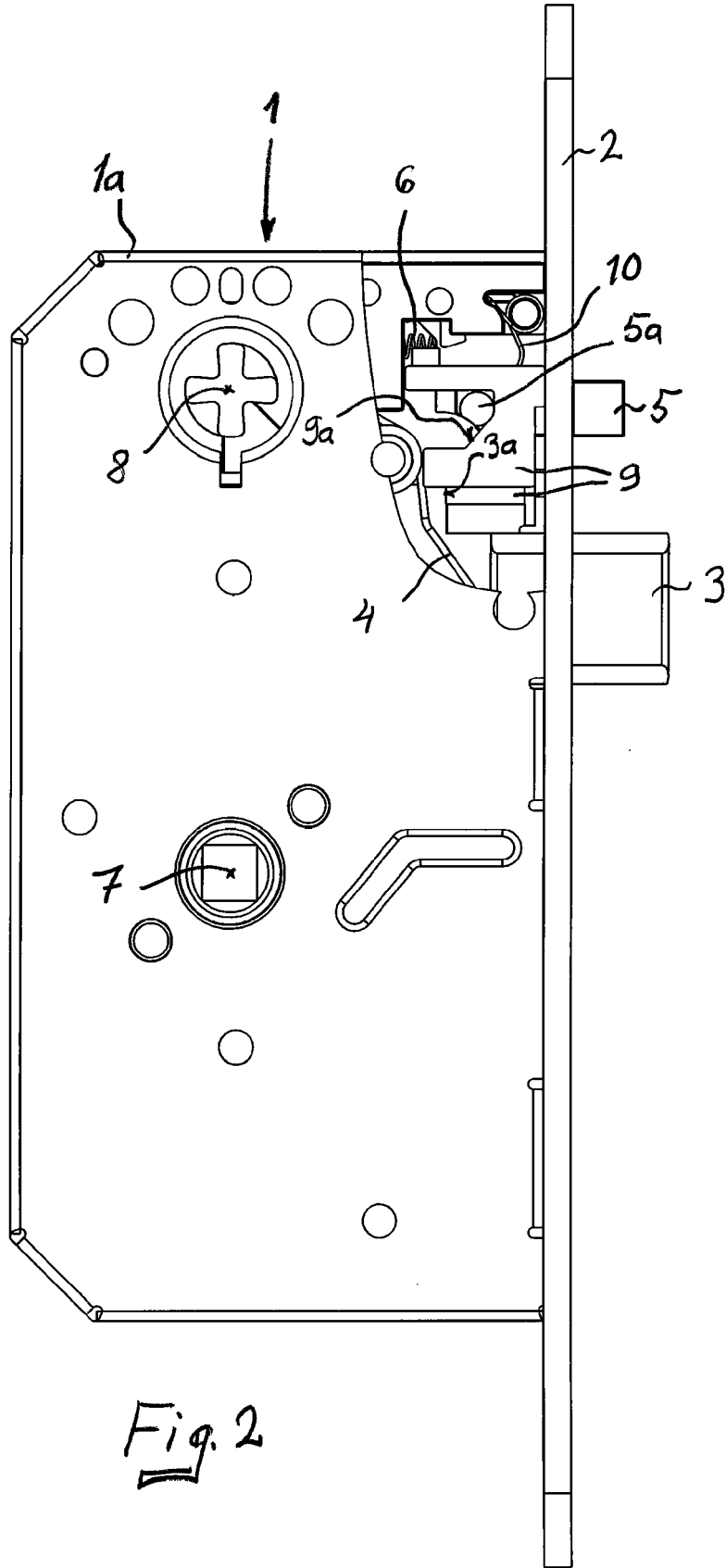

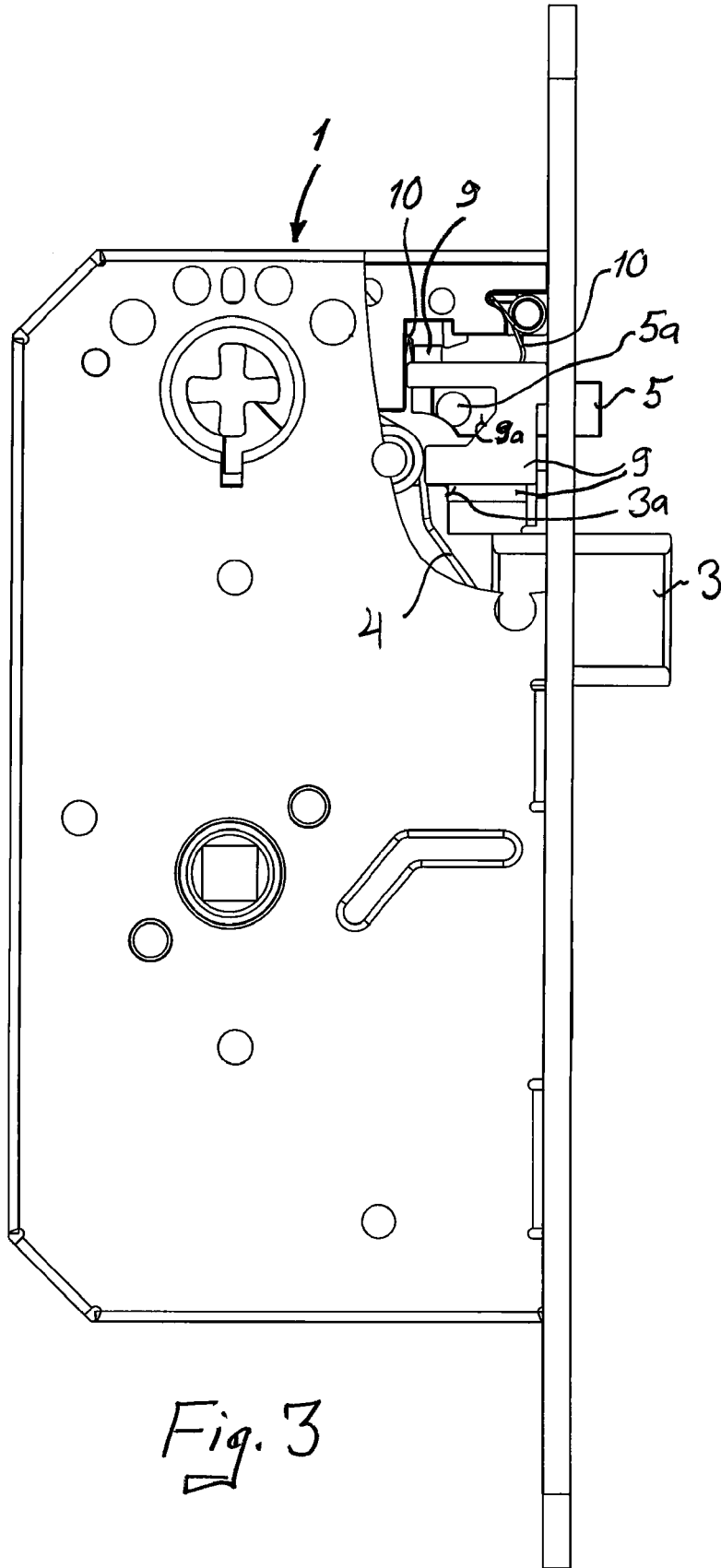

Fig. 3

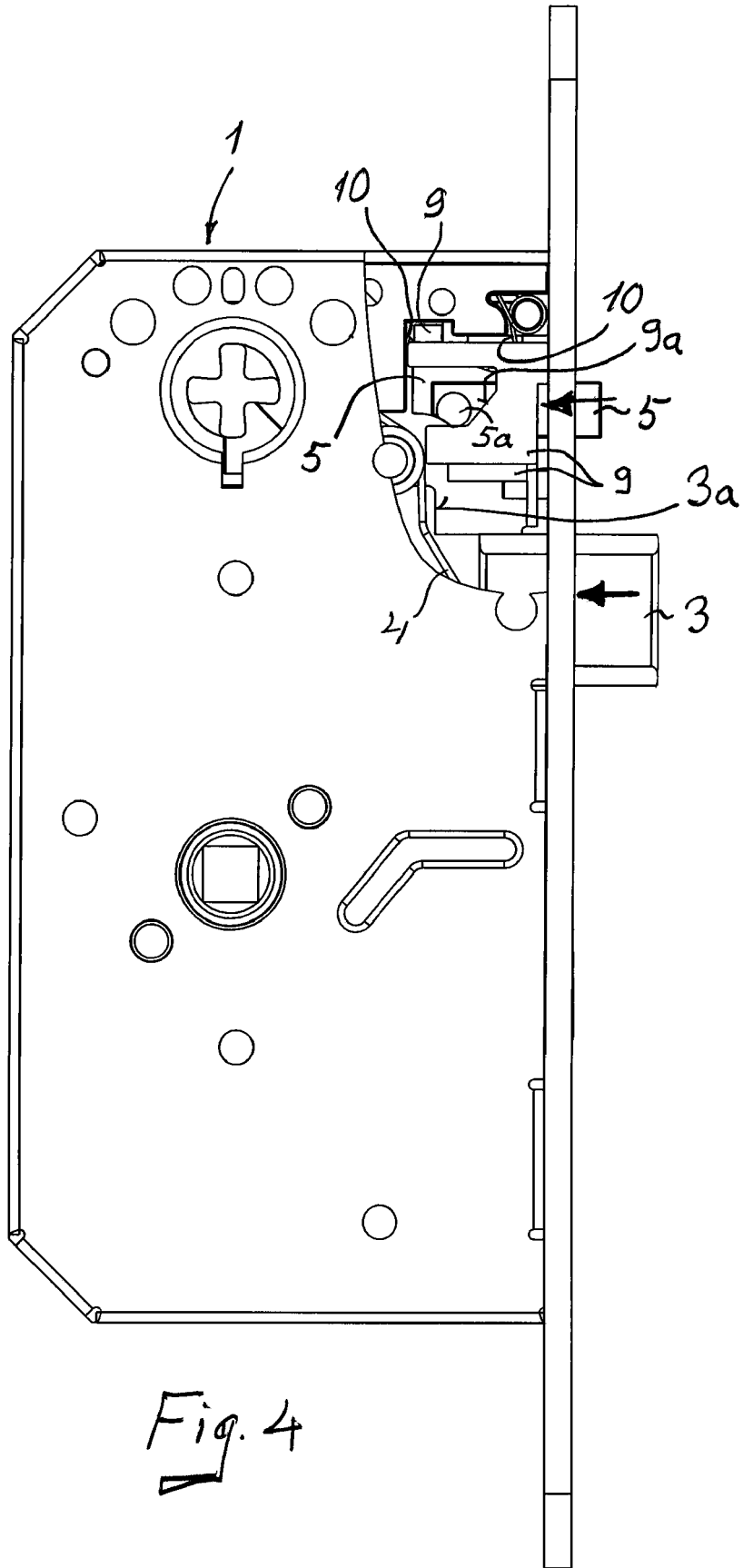

Fig. 4

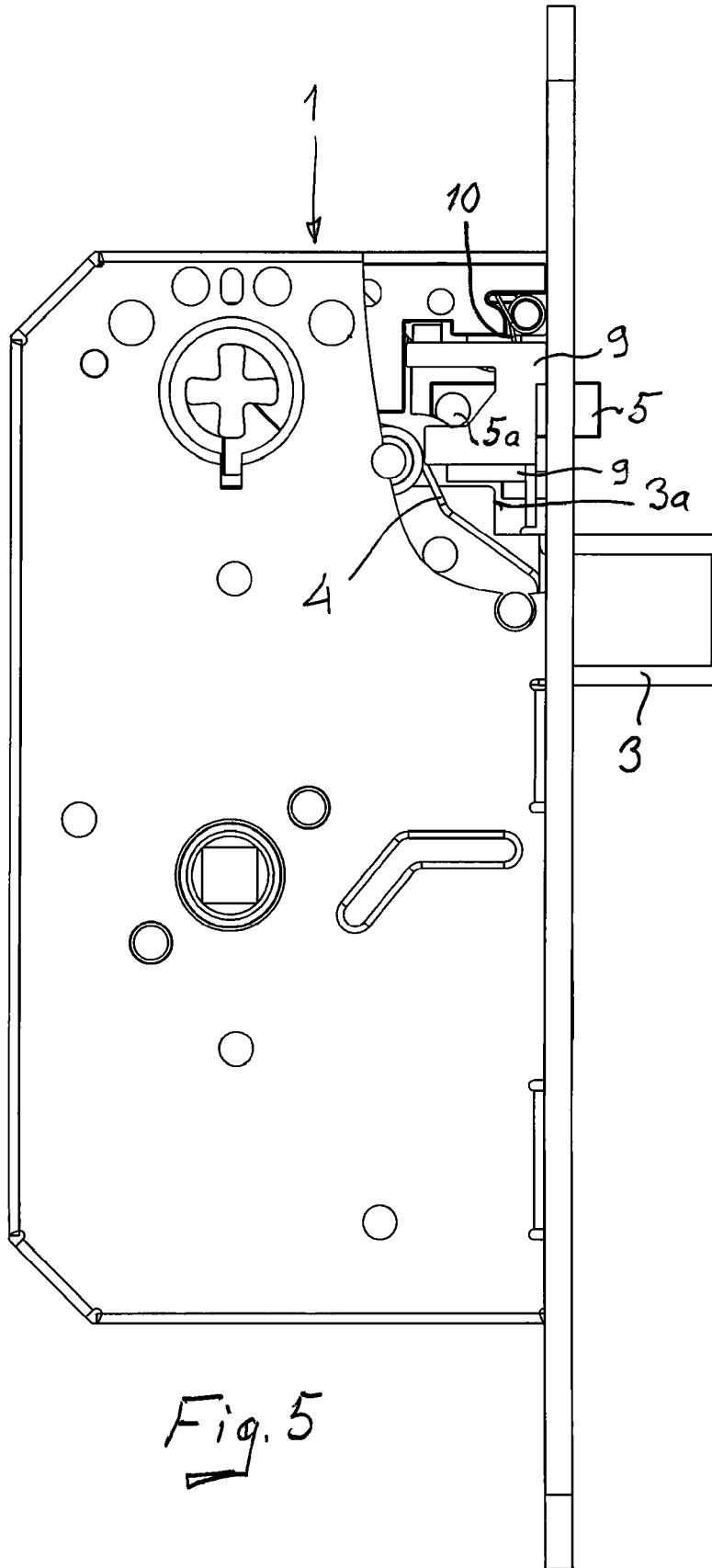

Fig. 5

REFERENCES CITED IN THE DESCRIPTION

This list of references cited by the applicant is for the reader's convenience only. It does not form part of the European patent document. Even though great care has been taken in compiling the references, errors or omissions cannot be excluded and the EPO disclaims all liability in this regard.

Patent documents cited in the description

- FI 115066 [0004]
- WO 0266774 A1 [0004]