

(No Model.)

O. V. SIGURDSSON.  
LINO TYPE MACHINE.

No. 524,285.

Patented Aug. 7, 1894.

*Fig. 1.*

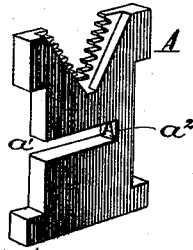

*Fig. 2.*

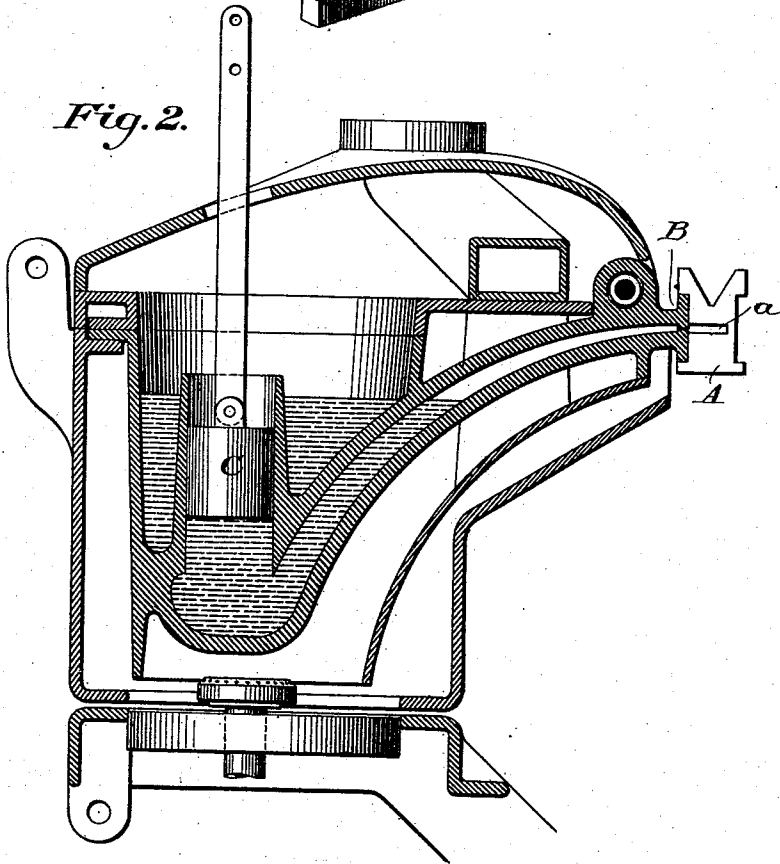

Witnesses  
*Raymond T. Barnes*  
*F. S. Elmore*

Inventor  
*O. V. Sigurdsson*  
*By P. Y. Lodge*  
Attorney

# UNITED STATES PATENT OFFICE.

ODDUR V. SIGURDSSON, OF BROOKLYN, NEW YORK, ASSIGNOR TO THE  
MERGENTHALER LINOTYPE COMPANY.

## LINOTYPE-MACHINE.

SPECIFICATION forming part of Letters Patent No. 524,285, dated August 7, 1894.

Application filed July 8, 1893, Serial No. 479,898. (No model.)

*To all whom it may concern:*

Be it known that I, ODDUR V. SIGURDSSON, of Brooklyn, county of Kings, and State of New York, have invented a new and useful Improvement in Linotype-Machines, of which the following is a specification.

My invention relates to linotype machines in which a series of type matrices, containing individual characters, are selected and assembled in line, so that a linotype or slug cast or molded against the line will bear in relief the characters to print an entire line. Heretofore it has been customary to cast the slug or linotype in a mold, against which the matrices were temporarily assembled so as to close the same and present their characters to the interior of the mold.

My invention is intended to overcome the necessity for this mold, and consists in forming the matrices with deep slots having the matrices proper at the bottom, so that when a series of matrices are assembled side by side, their slots standing in line, will form a mold in which to cast a linotype. Matrices thus constructed will serve both as molds and as matrices. In other words, they will give form to the bar or linotype and also produce the characters on its edge. The matrices may be made of any suitable material, and of any size and external form required in order to adapt them for use in different classes of machines, and with different composing and assembling mechanisms of said machines.

Figure 1, is a perspective view of a matrix on my plan, adapted for use in a machine having composing and distributing devices, like those of the ordinary Mergenthaler linotype; and Fig. 2, is a cross-section, showing the manner in which a line of matrices will be used in connection with the melting pot to produce a slug or linotype.

A represents the body of the matrix; *a* a slot or groove therein, and *a*<sup>2</sup> the matrix proper.

B represents the mouth of the melting pot

arranged to close tightly against the rear faces of a composed line of matrices, so as to close the slots therein. The pot may be provided like the linotype machines with the pump plunger C to deliver the molten metal into the slots of the matrices. The pot will be heated by a burner thereunder as usual.

The matrices herein shown may be used in combination with solid spaces of corresponding form and of suitable thicknesses, or with adjustable spaces of any suitable character adapted for use with them. In an organized machine, suitable appliances will of course be provided for ejecting the linotype or cast from the matrices. These features, however, form no part of the present invention. The matrices at the ends of the line will have their slots covered or closed by the usual clamping jaws, or other covering devices, to prevent leakage of metal.

What I claim as my invention is—

1. A linotype matrix having therein a deep slot to give form to the two opposite sides of a linotype or slug, and a matrix proper at the bottom of the said slot.

2. A combination of a series of matrices slotted as described to give form to the opposite sides of the cast, and means for delivering molten metal or equivalent material therein.

3. The combination of a series of matrices having slots corresponding with the sectional form of the required linotype, and a melting pot adapted to fit against and close the rear side of the matrices and to deliver molten metal into the slot thereof, substantially as described.

In testimony whereof I hereunto set my hand, this 6th day of July, 1893, in the presence of two attesting witnesses.

ODDUR V. SIGURDSSON.

Witnesses:

FREDK. J. WARBURTON,  
S. CRUTCHFIELD.