

(No Model.)

3 Sheets—Sheet 1.

F. W. DENNIS.  
COMBINATION DOWNDRAFT KILN.

No. 523,330.

Patented July 24, 1894.

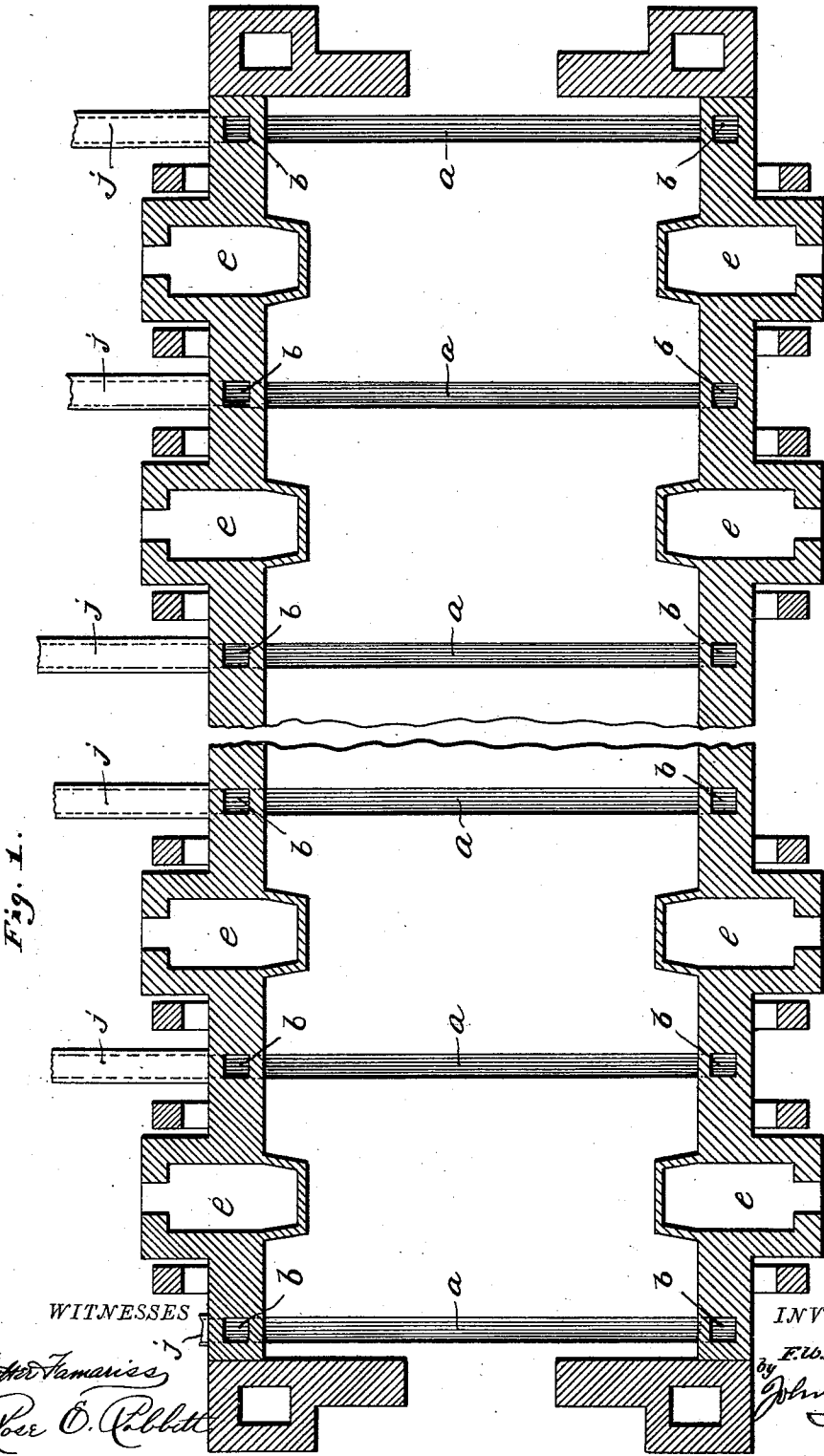

*Walter Tamaris*  
*Ross O. Collett*

*F. W. Dennis*  
by *John S. Duffie*  
Attorney

(No Model.)

3 Sheets—Sheet 2.

# F. W. DENNIS. COMBINATION DOWNDRAFT KILN.

No. 523,330.

Patented July 24, 1894.

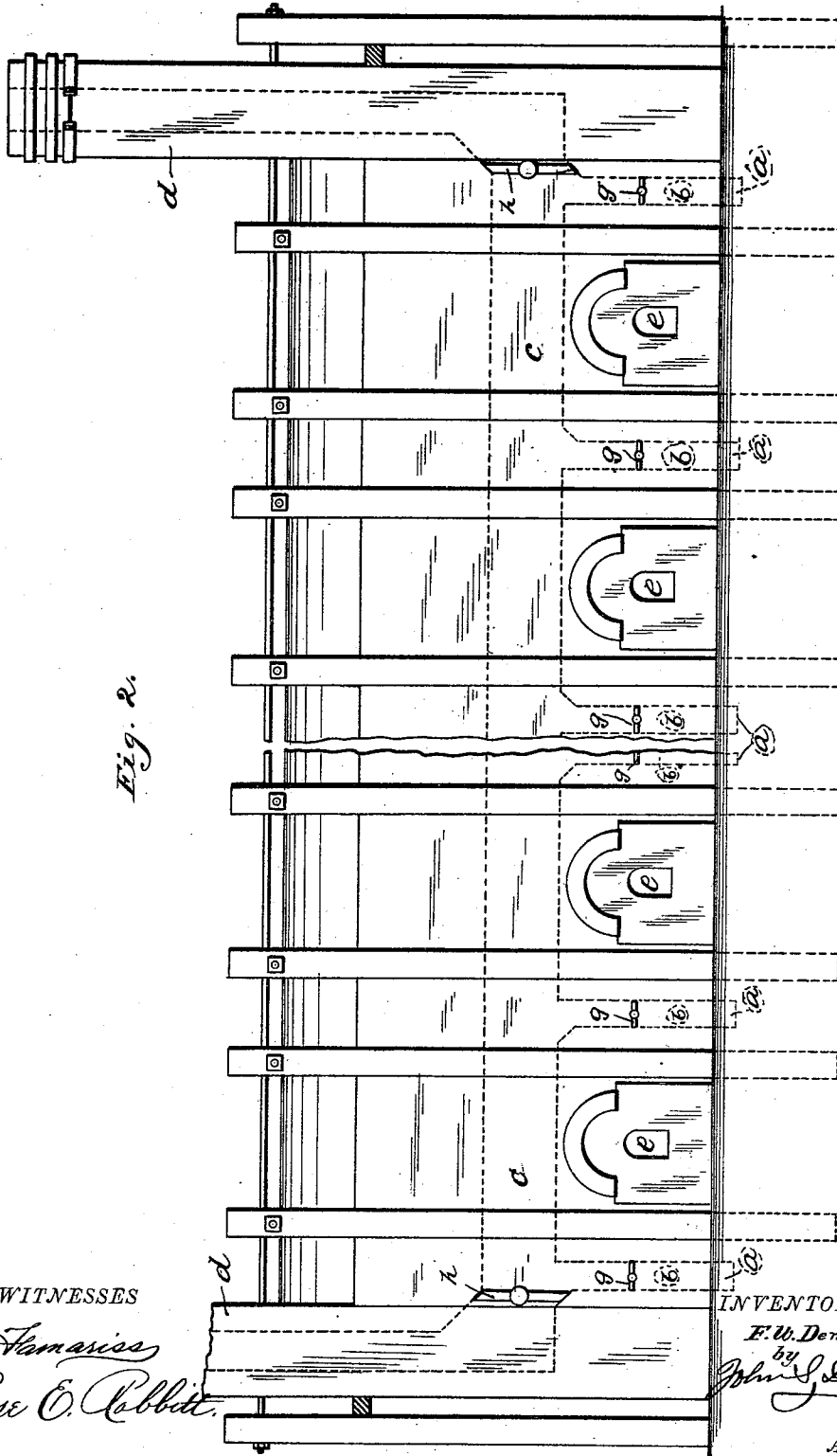

Fig. 2.

WITNESSES

*Walter Hamariss*  
*Rose O. Rabbit.*

INVENTOR

*F. W. Dennis.*  
by *John S. Duffie*

Attorney

F. W. DENNIS.  
COMBINATION DOWNDRAFT KILN.

No. 523,330.

Patented July 24, 1894.

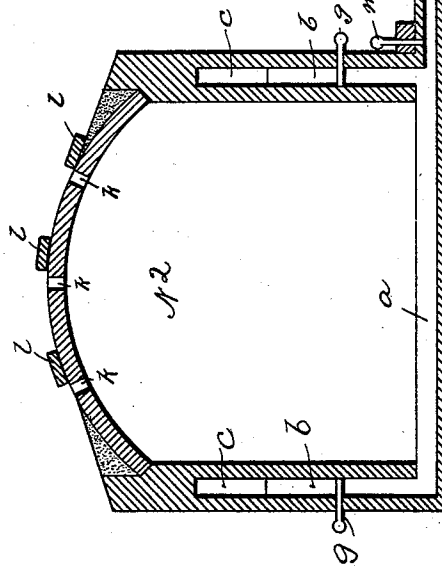
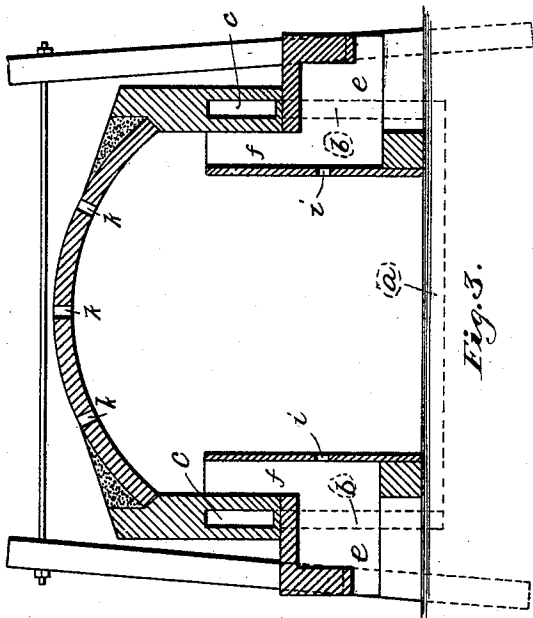
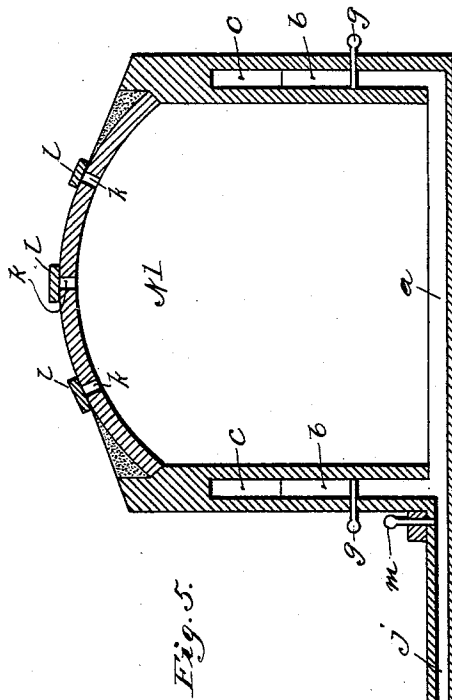
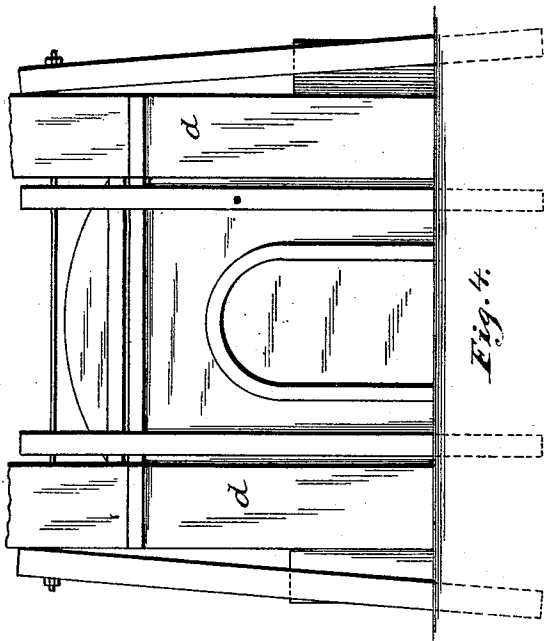

WITNESSES

*Walter Jamieson*  
*Rose C. Rabbitt.*

INVENTOR

*F. W. Dennis.*  
*by John Duffie*

Attorney

# UNITED STATES PATENT OFFICE.

FREDRICK WALTER DENNIS, OF OCALA, FLORIDA.

## COMBINATION DOWNDRAFT-KILN.

SPECIFICATION forming part of Letters Patent No. 523,330, dated July 24, 1894.

Application filed February 27, 1894. Serial No. 501,670. (No model.)

*To all whom it may concern:*

Be it known that I, FREDRICK WALTER DENNIS, a citizen of the United States, residing at Ocala, in the county of Marion and State of Florida, have invented certain new and useful Improvements in Combination Downdraft-Kilns; and I do hereby declare the following to be a full, clear, and exact description of the invention, such as will enable others skilled in the art to which it appertains to make and use the same.

My invention is a "combination down draft kiln;" and consists in the novel construction and arrangement of its parts, hereinafter set out in this specification and the claim thereunto attached.

In the accompanying drawings: Figure 1 is a plan view of my kiln, showing a part of the flues that connect it with an adjacent kiln. Fig. 2 is an elevation of the same. Fig. 3 is a cross sectional view, showing the fire boxes, flame pockets, side main flues and ground cross flues. Fig. 4 is an end view showing the doorway and framework. Fig. 5 is a cross section of the two kilns, showing the connection flues and the cut-offs.

My invention is described as follows:

The kiln is rectangular in shape having ground cross flues *a*, the top of which are even with the ground line, which lead into the upright flues *b*, which connect with the side main flues *c*, running lengthwise the kiln. These flues *c*, connect with chimneys *d*, (Fig. 2) located at each corner of the kiln.

On each side of the kiln proper distances apart are fire-boxes *e*, provided with flame pockets *f*.

In each side of the kiln, built in the walls thereof and running lengthwise of the kiln, are side main flues *c*, indicated by dotted lines Fig. 2. At each corner of the kiln are situated chimneys, into which these side main flues open. A damper *g*, is placed in each upright flue *b*; also a damper *h*, in each main flue, all of which are for regulating the heat in any portion of the kiln. In the back wall of each of the flame pockets *f*, are openings *i*, which are filled in with a temporary filling until the upper portion of the kiln is burned. Then these temporary fillings in said openings are removed and the heat allowed to pass direct from said flame pockets, through arches

left in the material to be burned to the lower portion of the kiln, burning the said lower portion of said material equal to the upper portion. In this manner the portion of the kiln, commonly known as the floor, is burned equal to the upper portion; the lower floor of any kiln being built of unburned brick, thereby saving not only an expensive floor, but, the space in the floor which the kiln occupies.

I build as many kilns as may be necessary in my work, all being exactly alike, however, and all being connected by connection flues *j*, which register with the ground cross flues *a*, and are laid from one kiln to the other, and pass the hot air from the kiln which has just been burned to the kiln of green brick, and so on to the far end of the line of kilns, and then back again in the same manner to the near end. In practice, however, I have found that I can get along very well with two kilns, but in very large brick yards three, four, or any number may be used. By this arrangement the kiln which has just been burned, cooling off, its hot air passes to the next kiln, thus saving the heat which otherwise would be wasted, and this is equivalent to a half burning of the green kiln.

Number 1, is a kiln of brick just finished burning.

Number 2, is a kiln of green brick ready to be dried off.

*k*, are openings in the top of the kilns for cooling off and light.

*l*, are bricks to cover the openings *k*, on the top of the kilns.

*m*, are dampers to shut off each kiln by itself.

The action of the heat in this combination down draft kiln is as follows: The heat being generated in the fire-boxes *e*, on either side of the kiln, passes up through the flame pockets *f*, leading from the fire boxes and down through the material to be burned to the ground cross flues *a*, running crosswise the kiln; then up through flues *b*, into the side main flues *c*, and thence out of the chimneys *d*. The heat, however, may be regulated and shifted from one part of the kiln to the other, by means of the dampers and the temporary fillings in the openings *i*, in the rear walls of the flame pockets.

The way I work the kilns is this: I burn off kiln No. 1, and kiln No. 2, being filled with green material, I stop all drafts in Nos. 1 and 2, and then open the dampers *m*, in the connection flues, and remove the bricks *l*, from the openings *k*, in kiln No. 2. Thus the heat passes into kiln No. 2, through the connection flues, ground cross flues *a*, thence up through the material to be burned and out of the openings *k*, in the top of the kiln. When this waste heat has sufficiently dried the material in the kiln No. 2, the dampers *m*, are closed and said kiln is fired and burned the same as No. 1 was burned, and then kiln No. 1, having been filled with green material, kiln No. 2 is closed and the dampers *m*, are again opened, the bricks *l*, removed, and the wasted heat forced to pass back through the connection flues *j*, into kiln No. 1.

20 Having described my invention, what I

claim as new, and desire to secure by Letters Patent, is—

The combination down draft kiln, consisting of the kilns Nos. 1 and 2, each kiln being provided with ground cross flues *a*, connection flues *j*, dampers *m*; fire-boxes *e*, provided with flame pockets *f*, having openings *i*; side main flues *c*, leading into chimneys *d*; upright flues *b*, rising from the ground cross flues *a*, and opening into said side main flues; dampers *g*, in flues *b*; dampers *h*, in side main flues *c*; and openings *k*, in the roof of the kiln, substantially as shown and described and for the purposes set forth.

In testimony whereof I affix my signature in presence of two witnesses.

FREDRICK WALTER DENNIS.

Witnesses:

CHARLES W. MOFFATT,

THOMAS J. MUSSELWHITE.