

Aug. 16, 1966

P. HASLER

3,267,276

STREET LANTERN

Filed Nov. 12, 1963

Fig. 2

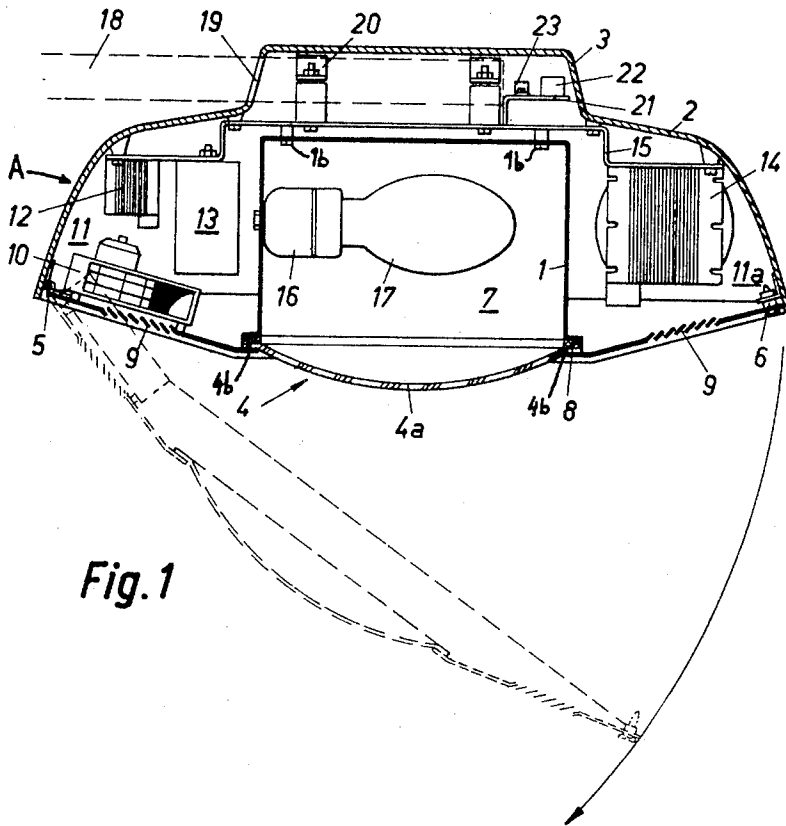
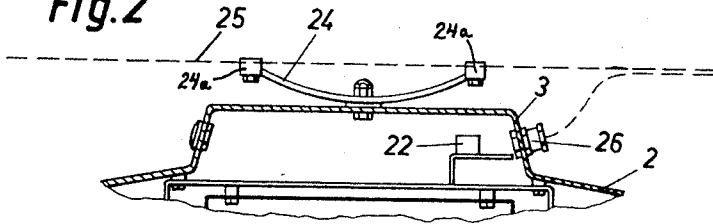

Fig. 1

PAUL HASLER  
INVENTOR

BY *Jerome W. Kleeman*  
Attorney

1

3,267,276

## STREET LANTERN

Paul Hasler, Zurich, Switzerland, assignor to Novelectric AG., Zurich, Switzerland, a corporation of Switzerland  
Filed Nov. 12, 1963, Ser. No. 322,776

Claims priority, application Switzerland, Nov. 20, 1962,  
13,584/62

6 Claims. (Cl. 240—25)

The present invention broadly relates to an improved street lantern or similar lighting fixture.

Different constructions of street lanterns are known to the art, either designed for suspension upon an overhead support arrangement or for attachment to a post or mast. For such purpose it is always necessary to provide special attachment means which, for example, are arranged upon the globe or housing encircling the lamp, the reflector, the electric circuit components such as coils and capacitors, of the lantern. Additionally, for the suspension of the street lantern upon overhead supports it is necessary that the lantern be balanced with respect to its point of suspension, for which purpose there is required a particular globe shape which permits of uniform distribution of weight, especially for the circuit components. Such globes, however, are unsuitable for attachment to posts, for which reason a different lantern type must be employed.

Such factors therefore require that there be provided at least two different types of lantern, consequently necessitating that there is maintained an extensive manufacturing program and, in addition thereto, a predetermination of the relation of lanterns for posts to lanterns for overhead supports. Moreover, with street lamps or lanterns it is further necessary to protect the reflector from dust deposits, such not having been satisfactorily accomplished up to the present with heretofore known street lantern constructions, for which reason the latter had to be continually cleaned at regular, relatively short time intervals.

Additionally, it is also necessary to allow for correct circulation of air and thereby cooling of the internal compartments of the globe, without dust particles entrained by the air being able to enter the lamp compartment of the reflector. This has not been satisfactorily accomplished up to the present with known street lamp constructions.

Accordingly, it is a primary object of this invention to provide a street lantern which can be optionally suspended upon overhead supports as well as also capable of being attached to mast rods or posts, and which further renders possible a dustproof covering of the reflector.

Another important object of the present invention is the provision of an improved street lantern which can be supported in a balanced manner either by an overhead support or a post, is relatively inexpensive to manufacture, quite simple in construction, easy to service, and positively prevents the entry of dust into the lamp compartment.

The inventive street lantern or lamp is generally characterized by the features that, the globe or housing is symmetrically arranged with respect to the reflector, encircling the latter in spaced relation therefrom, and that the reflector in turn encircles the lamp in a cap or cover-like manner. Additionally, at the face or side of the globe where the light departs there is provided an at least partially detachable cover unit which has a light permeable or transmissive central portion, the marginal zone of which in the closed position of such cover unit cooperates with the edge or periphery of the reflector to provide a dustproof obturation of the lamp compartment formed by the reflector.

Still further objects and the entire scope of applicability

2

of the present invention will become apparent from the detailed description given hereinafter; it should be understood, however, that the detailed description and specific examples, while indicating preferred embodiments of the invention, are given by way of illustration only, since various changes and modifications within the spirit and scope of the invention will become apparent to those skilled in the art from this detailed description.

In the drawing:

FIGURE 1 is a vertical sectional view taken through a street lantern designed according to the present invention, and which is connected to a horizontal mast rod or post; and

FIGURE 2 is a fragmentary, vertical sectional view of the street lantern of FIGURE 1, depicted for the purpose of illustrating its mode of securement to an overhead support.

Referring now more specifically to the embodiment of FIGURE 1, it should be recognized that the street lantern or lighting fixture A illustrated therein incorporates a reflector 1 open towards its bottom or lower end, and which in the illustrated embodiment is symmetrically surrounded or encircled by a substantially bell-shaped housing or globe 2. The globe 2 is advantageously constructed to be step-shaped, with the reduced upper portion 3 extending upwardly in the illustrated embodiment, whereas the open side or end of the globe 2 situated opposite the reduced portion 3 is closeable by means of a cover member 4. Now it will be seen that in this embodiment the cover member 4 is hingedly connected to the left side of the globe 2 by means of a hinge joint 5 or the like, and in its closed position is lockable by means of a quick-closing screw 6 or otherwise arranged at the side of the globe 2 opposite the hinge joint 5.

This cover member 4 is advantageously provided with a central portion 4a which permits the transmission or passage of light, preferably formed from a synthetic glass trough, and which in the closed position of the aforesaid cover member seals in a dustproof manner the lamp compartment 7 formed by the reflector 1, for which purpose there is advantageously provided at the lower marginal edge 1a of the reflector 1 an additional seal 8 against which bears the shoulder-like edges 4b of the synthetic glass trough, that is, the central portion 4a. The cover member 4 is provided at both sides of the central portion 4a with air slots 9 or the like which permit of air passage. In order to convey the air and to generate a circulation internally of the globe 2 a ventilator 10 is arranged at the inner face of the cover member 4 and adjacent the air slots 9 depicted at the left side of the arrangement. This ventilator 10 extends into the compartment 11 of the compartments 11 and 11a appearing at both sides of the reflector 1 and formed between such reflector and the internal walls of the globe 2.

Furthermore, in the compartment 11 there is arranged a locking coil 12 necessary for the lamp circuit as well as a capacitor 13, and in the compartment 11a there is arranged an additional coil 14. These electric circuit components 12, 13 and 14 are connected to a support plate 15 disposed in the upper region of the globe 2 and which is rigidly connected therewith by any suitable connecting means or expedients. The reflector 1 is screwed, as at 1b, or otherwise connected in spaced relation to the support plate 15, in the manner shown in FIGURE 1, and such that the air circulating within the lantern can freely flow between the support plate 15 and the reflector 1. Internally of the reflector 1 there is additionally arranged a lamp socket 16 in which a vapor lamp 17 or otherwise can be threaded.

On account of the described arrangement of the street lantern A there is rendered possible a uniform weight

distribution with respect to the plane of symmetry of the lantern and which guarantees for a balanced suspension or hanging thereof, especially when the lantern is employed with overhead supports. Additionally, the construction of the globe 2 and the arrangement of the reflector 1 in the center of the globe 2 permits of a faultless circulation of air and therewith a cooling of the internal compartments of such globe, without the dust particles entrained by the air being able to enter the lamp compartment 7 of the reflector 1. Moreover, the articulated cover member 4 which can be locked in position by the quick-locking screw 6 permits for a rapid and facile replacement of the vapor lamp 17.

In order to secure the lantern to an approximately horizontal mast extension 18 the jacket surface of the reduced upper portion 3 of the globe 2 is provided with an opening 19 through which piercingly extends the free end of the aforesaid mast or post extension 18. In order to connect the street lantern A to the mast extension 18 there is advantageously provided internally of the reduced portion 3 a pair of mast fastening means or clamps 20 which are secured to the support plate 15. Additionally, there is arranged internally of the reduced portion 3 and opposite the opening 19 a support angle member 21 preferably seated upon the support plate 15 and to which there is connected a connection terminal 22 for the conductor wires or electric leads which are led through the mast extension 18. In order to relieve the conductors there can be further provided traction relief means 23.

For the purpose of suspending the street lantern A at an overhead suspension or support arrangement the reduced portion 3 is provided, in accordance with FIGURE 2, and externally thereof at the frontal face with a cable stirrup 24, the free ends of which are fixedly clamped by suitable clamp means 24a to an overhead suspension cable 25. For the conductor leads or electric wires there is provided a stuffing box 26 in the jacket surface of the reduced upper portion 3 and through which there is lead the conductors to the connecting terminal 22 disposed internally of the aforesaid reduced upper portion 3.

The described street lantern thus permits a selective suspension upon overhead supports as well as also an attachment to mast rods or the like, without considerable changes having to be undertaken with the street lantern. Thus, the street lantern can be initially prepared for connection to masts and to overhead supports to such a degree that if the street lantern is to be suspended at an overhead support then only the cable stirrup 24 must be screwed thereon. For reasons of material-saving and for this purpose the mast fastening means can be removed. It is, however, also conceivable to manufacture the street lantern such that after the predetermined bringing thereof to the place of erection, either the opening 19 is produced and the fastening means 20 threaded thereon, or the stuffing box 27 and the cable stirrup 24 is applied.

While there is shown and described present preferred embodiments of the invention it is to be distinctly understood that the invention is not limited thereto but may be otherwise variously embodied and practised within the scope of the following claims.

Having thus described the present invention, what is desired to be secured by United States Letters Patent is:

1. Street lantern comprising a hollow outer globe member including an open end for the departure of light, a reflector arranged within said outer globe member, said outer globe member encircling said reflector in spaced relation to provide a flow passage externally of said reflector for the circulation of air for cooling said reflector, said outer globe member being symmetrically disposed with respect to said reflector, said reflector providing a lamp compartment, at least one lamp situated within said lamp compartment, said reflector surround-

ing said lamp in hood-like manner, electric circuit components for said lamp, at least a partially detachable cover member provided at said open end of said outer globe member, said cover member including a light transmissive central portion having marginal portions bearing in sealing manner against the outer extremities of said reflector in the closed position of said cover member to provide dustproof sealing of said lamp compartment formed by said reflector, said cover member being provided with slot means at both sides of said light transmissive central portion and outside the confines of said reflector, said slot means communicating with said flow passage for the circulation of air, and ventilator means located adjacent the slot means disposed at one side of said central portion for drawing air into said flow passage for cooling said reflector, said drawn-in air being unable to enter the lamp compartment of said reflector due to said dustproof sealing thereof.

2. Street lantern as defined in claim 1 wherein said cover member is hingedly connected to the edge of said outer globe member, and quick-locking means for locking said cover member in closed position.

3. Street lantern as defined in claim 1 wherein said light transmissive central portion of said cover member exhibits an offset edge against which bears the edge of said reflector in the closed position of said cover member, a seal member situated between said edge of said central portion and said edge of the reflector.

4. Street lantern as defined in claim 1 wherein for the purpose of securing said street lantern to a mast there is provided at the wall of said outer globe member an opening through which is adapted to piercingly extend a horizontal mast rod.

5. Street lantern as defined in claim 1 wherein for the purpose of securing said street lantern to an overhead support arrangement cable stirrup means are arranged at said outer globe member.

6. Street lantern comprising a hollow outer globe member including an open end for the departure of light, a reflector arranged within said outer globe member, said outer globe member encircling said reflector in spaced relation to provide a flow passage externally of said reflector for the circulation of air for cooling said reflector, said outer globe member being symmetrically disposed with respect to said reflector, said reflector providing a lamp compartment, at least one lamp situated in said lamp compartment with said reflector surrounding said lamp in hood-like manner, electric circuit components for said lamp, at least a partially detachable cover member provided at said open end of said outer globe member, said detachable cover member including a light transmissive central portion having marginal portions bearing in sealing manner against the outer extremities of said reflector in the closed position of said cover member to provide dustproof sealing of said lamp compartment formed by said reflector, and means communicating with said flow passage for the circulation of air enabling a supply of air to be drawn into said flow passage from externally of said street lantern.

#### References Cited by the Examiner

##### UNITED STATES PATENTS

1,240,452	9/1917	Hotchkin	-----	240-47
1,507,367	9/1924	Edelstein	-----	240-47 X
2,276,559	3/1942	Bashore	-----	240-25 X
2,295,863	9/1942	Paradis	-----	240-47
2,570,907	10/1951	Arenberg et al.	-----	240-78 X
3,065,338	11/1962	Husby et al.	-----	240-25

NORTON ANSHER, *Primary Examiner.*

C. R. RHODES, *Assistant Examiner.*